

**GENERAL NOTES**

1. THE PRODUCT SHOWN HEREIN IS DESIGNED AND MANUFACTURED TO COMPLY WITH THE REQUIREMENTS OF THE 2018 INTERNATIONAL BUILDING CODE AND 2018 INTERNATIONAL RESIDENTIAL CODE.
2. THIS DOCUMENT ADDRESSES ONLY PRODUCT ANCHORAGE TO ACHIEVE THE INDICATED DESIGN PRESSURES AT THE INDICATED SIZES, IN THE CONFIGURATION SHOWN IN THE ELEVATIONS. INSTALL PRODUCTS WITH MAXIMUM SHIM GAP, MINIMUM EDGE DISTANCE AND EMBEDMENT, AND WITH FASTENER TYPE AS SHOWN IN THE DETAILS AND AS INDICATED IN TABLE 1. FOR FULL PRODUCT CONSTRUCTION DETAILS SEE ATI/INTERTEK TEST REPORT J4090.02-501-44-R1.
3. THIS PRODUCT AS SHOWN IN THIS DRAWING IS NON-IMPACT RESISTANT AND REQUIRES THE USE OF IMPACT PROTECTIVE DEVICES (SHUTTERS) IN WINDBORNE DEBRIS REGIONS.
4. INSTALLED GLAZING SHALL MEET ASTM E-1300 FOR THE APPLICABLE DESIGN PRESSURES AND WINDOW SIZE.
5. THE 4/3 ALLOWABLE STRESS INCREASE FACTOR (SHORT-TERM INCREASE FACTOR) HAS NOT BEEN USED IN THE ANCHOR ANALYSIS FOR THIS SYSTEM. THE 1.6 Cd FACTOR WAS USED IN THE ANALYSIS OF ANCHORAGE INTO WOOD SUBSTRATE.
6. THE OPENING SUBSTRATE MATERIALS (FRAMING, MASONRY, BUCKS) AND ATTACHMENT OF BUCKS TO THE SUBSTRATE ARE BY OTHERS AND SHALL BE VERIFIED BY THE ARCHITECT OR ENGINEER OF RECORD OR AS APPROVED BY THE AUTHORITY HAVING JURISDICTION (AHJ). BUCKING, OPENINGS, & BUCKING FASTENERS MUST BE PROPERLY DESIGNED & INSTALLED BY OTHERS IN ACCORDANCE WITH THE FBC TO TRANSFER SUPERIMPOSED LOADS TO THE STRUCTURE. WITH MASONRY OPENINGS, WOOD BUCKS ARE OPTIONAL.
7. DISSIMILAR MATERIALS THAT COME INTO CONTACT SHALL BE COATED OR OTHERWISE PROTECTED TO PREVENT GALVANIC REACTIONS. WOOD BUCKS, IF USED, SHALL BE PRESSURE TREATED, WITH EITHER A TREATMENT OR COATING COMPATIBLE WITH THIS PRODUCT.
8. ANCHORAGE NOTES: ALL ANCHORS USED SHALL BE OF A MATERIAL OR HAVE A COATING COMPATIBLE WITH THE PRESSURE TREATED WOOD BUCKS AND ALL OTHER WINDOW MATERIALS. INSTALL ONE ANCHOR AT EACH LOCATION SHOWN IN THE ELEVATION. INSTALL SHIMS AT EACH ANCHOR LOCATION WHERE A GAP OF 1/16" OR GREATER EXISTS BETWEEN PRODUCT FRAME AND SUBSTRATE. SHIMS SHALL BE LOAD-BEARING (PLASTIC OR METALLIC) AND CAPABLE OF TRANSFERRING LOADS TO SUBSTRATE. SPECIFIED ANCHOR EMBEDMENT TO SUBSTRATE SHALL BE BEYOND WALL FINISH OR STUCCO. FOR MASONRY WITH WOOD BUCKS LESS THAN 1-1/2" THICK EMBEDMENT SHALL BE BEYOND WOOD BUCKS AND INTO MASONRY. WOOD BUCKS 1-1/2" THICK OR GREATER SHALL HAVE EMBEDMENT INTO THE WOOD BUCKS.
9. ALL HARDWARE & FASTENERS SHALL BE IN ACCORDANCE WITH THESE DRAWINGS, OR AS APPROVED, SIGNED, AND SEALED BY A TEXAS-REGISTERED PROFESSIONAL ENGINEER ON A SITE-SPECIFIC BASIS.
10. SEALING AND FLASHING STRATEGIES FOR OVERALL WATER INFILTRATION RESISTANCE OF THE INSTALLED PRODUCT SHALL BE THE RESPONSIBILITY OF OTHERS AND ARE NOT ADDRESSED BY THIS DOCUMENT.

**INSPIRA DOUBLE HUNG WINDOW, NON-IMPACT**

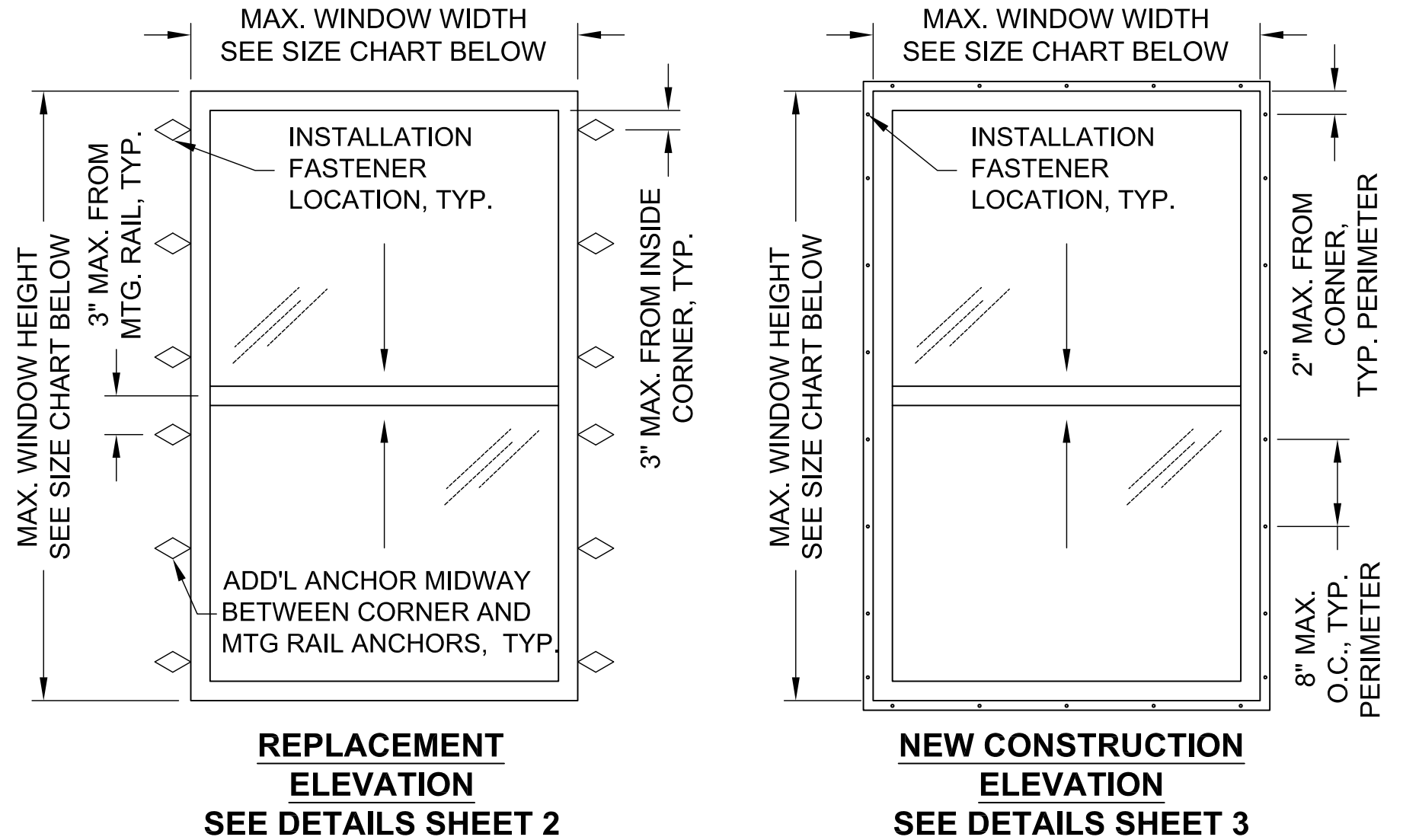

FRAME TYPE	MAX. SIZE	DESIGN PRESSURE RATING
NEW CONSTRUCTION	44" W X 75" H	+/-35 PSF
REPLACEMENT	44" W X 75" H	+/-35 PSF
NEW CONSTRUCTION	40" W X 63" H	+/-55 PSF
REPLACEMENT	40" W X 63" H	+/-50 PSF

**NORTHEAST BUILDING PRODUCTS**  
 4280 Aramingo Ave., Philadelphia, PA 19124  
 Ph. (215) 535-7110 www.camelotwindows.com

SHEET DESCRIPTION: NOTES, ELEVATION	DATE DRAWN: 2/7/2020
SCALE: NTS	REV: 0
DRAWING: TDI-INSPIRA-DH-NI	SHEET: 1 OF 3

11/12/2020  
 Lucas A. Turner, P.E.  
 TX PE #115094  
 2428 Old Natchez Trc Trl  
 Camden, TN 38320  
 Ph. 941-380-1574

# INSPIRA DOUBLE HUNG WINDOW, NON-IMPACT, REPLACEMENT

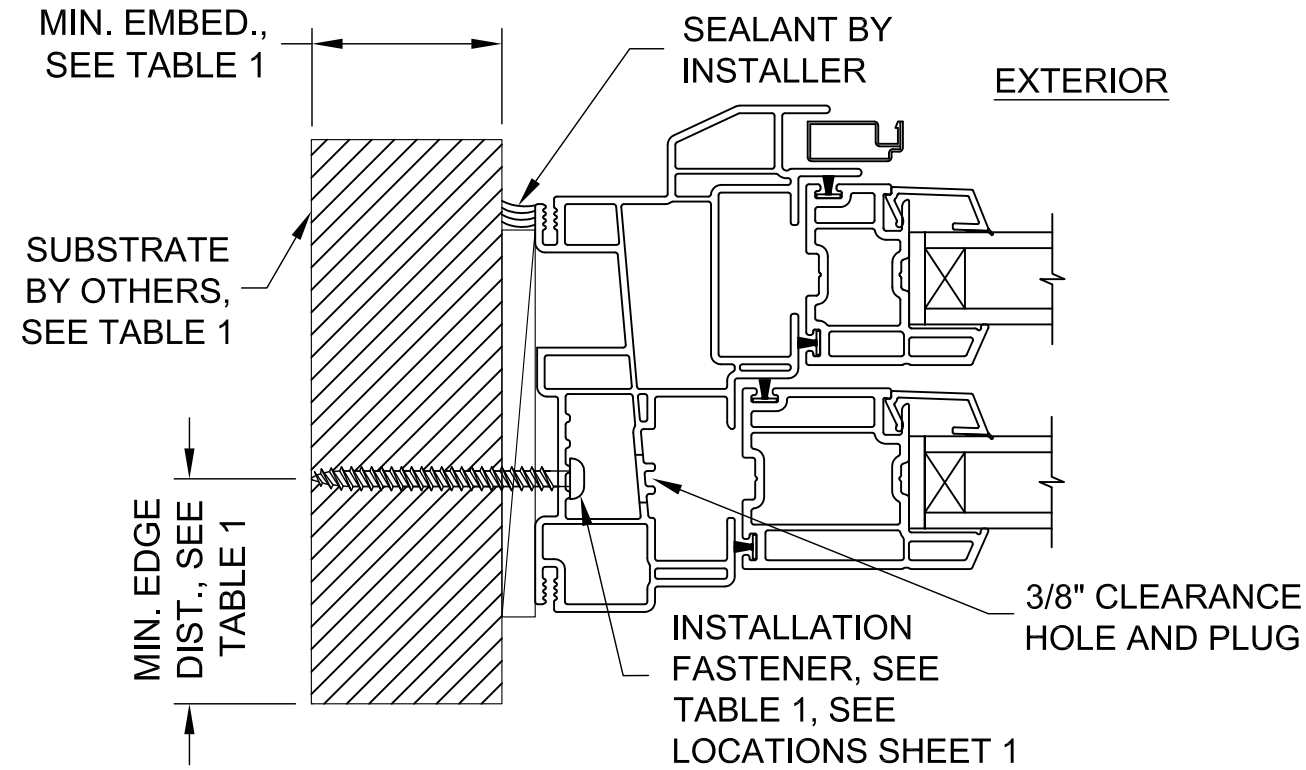

**TYPICAL JAMB HORIZONTAL SECTION**

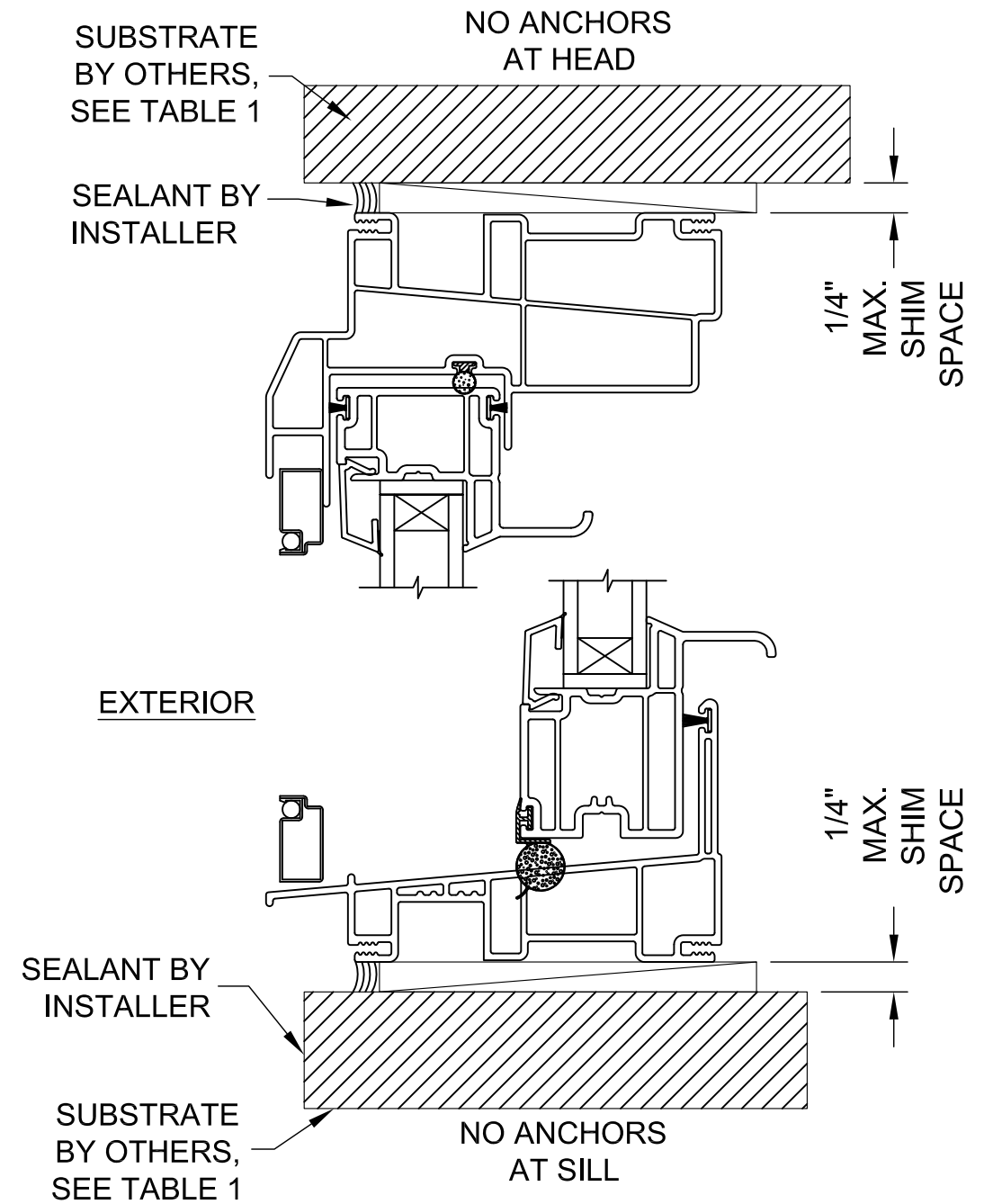

**TYPICAL FRAME  
VERTICAL SECTION**

TABLE 1: REPLACEMENT FRAME INSTALLATION ANCHOR REQUIREMENTS TABLE

SUBSTRATE TYPE	ANCHOR TYPE	MIN. EMBED.	MIN. EDGE DIST.
CONCRETE (2.0 KSI MIN)	3/16" ITW TAPCON	1"	1 1/8"
HOLLOW OR GROUT-FILLED CMU (117 PCF MIN.)	3/16" ITW TAPCON	1"	2"
CONCRETE (2.85 KSI MIN.)	3/16" ELCO ULTRACON	1"	1"
HOLLOW OR GROUT-FILLED CMU (ASTM C90)	3/16" ELCO ULTRACON	1-1/4"	2 1/2"
2X MIN. SPRUCE-PINE-FIR WOOD (G=0.42)	#8 WOOD SCREW	1-3/8"	1"
16 GAUGE (0.060") MIN. STEEL STUD, 33KSI YIELD MIN., OR 1/8" ALUM. 6063-T5 MIN.	#10-16 HILTI KWIK-FLEX OR ITW TEKS SELF-DRILLING SCREW	FULL	1/2"

## NORTHEAST BUILDING PRODUCTS

4280 Aramingo Ave., Philadelphia, PA 19124  
Ph. (215) 535-7110 www.camelotwindows.com

SHEET DESCRIPTION:  
REPLACEMENT INSTALLATION

SCALE: NTS

DRAWING: TDI-INSPIRA-DH-NI

DATE DRAWN:  
2/7/2020

REV: 0

SHEET: 2 OF 3



11/12/2020  
Lucas A. Turner, P.E.  
TX PE #115094  
2428 Old Natchez Trc Trl  
Camden, TN 38320  
Ph. 941-380-1574

# INSPIRA DOUBLE HUNG WINDOW, NON-IMPACT, NEW CONSTRUCTION

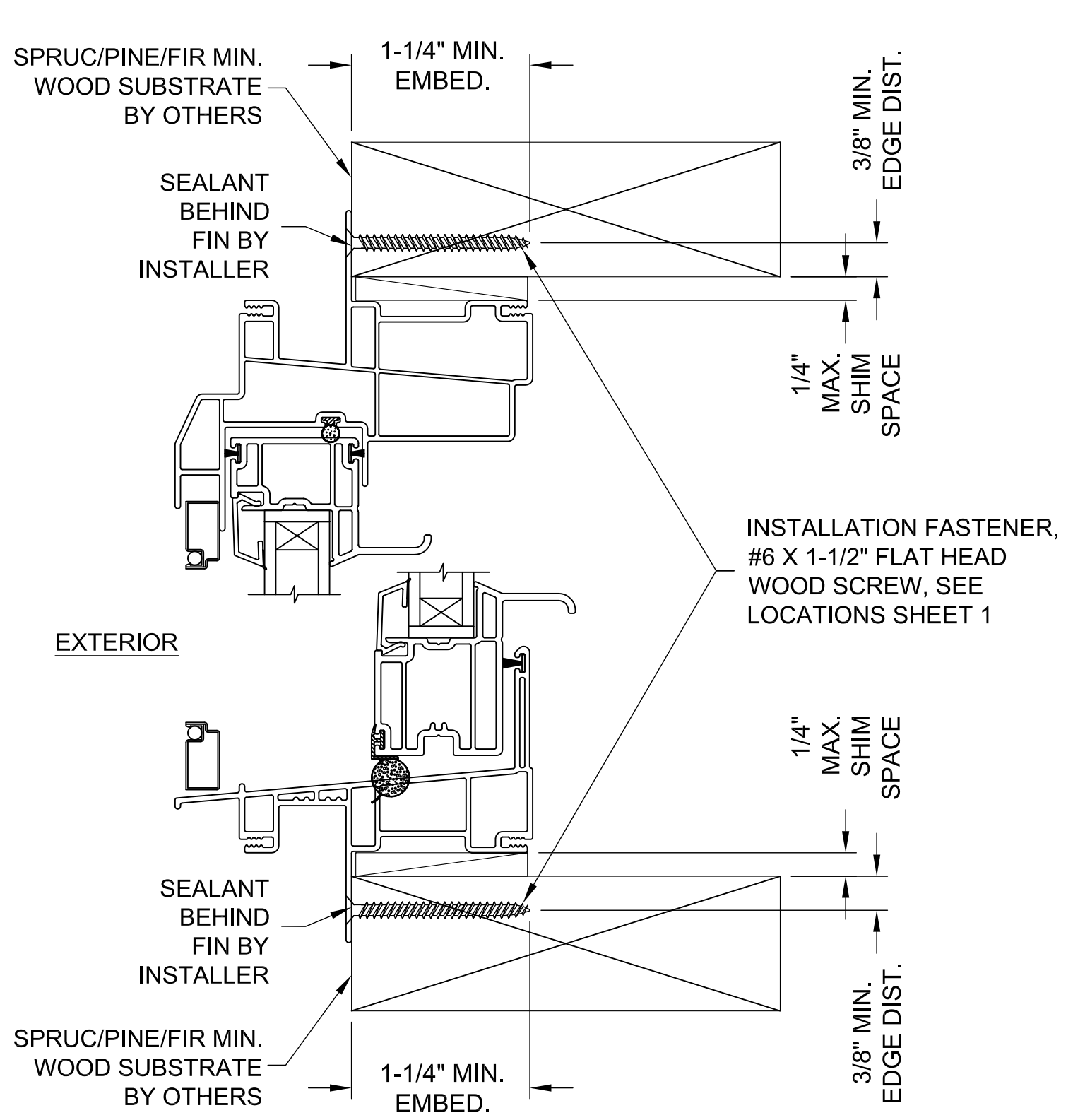

**TYPICAL FRAME VERTICAL SECTION**

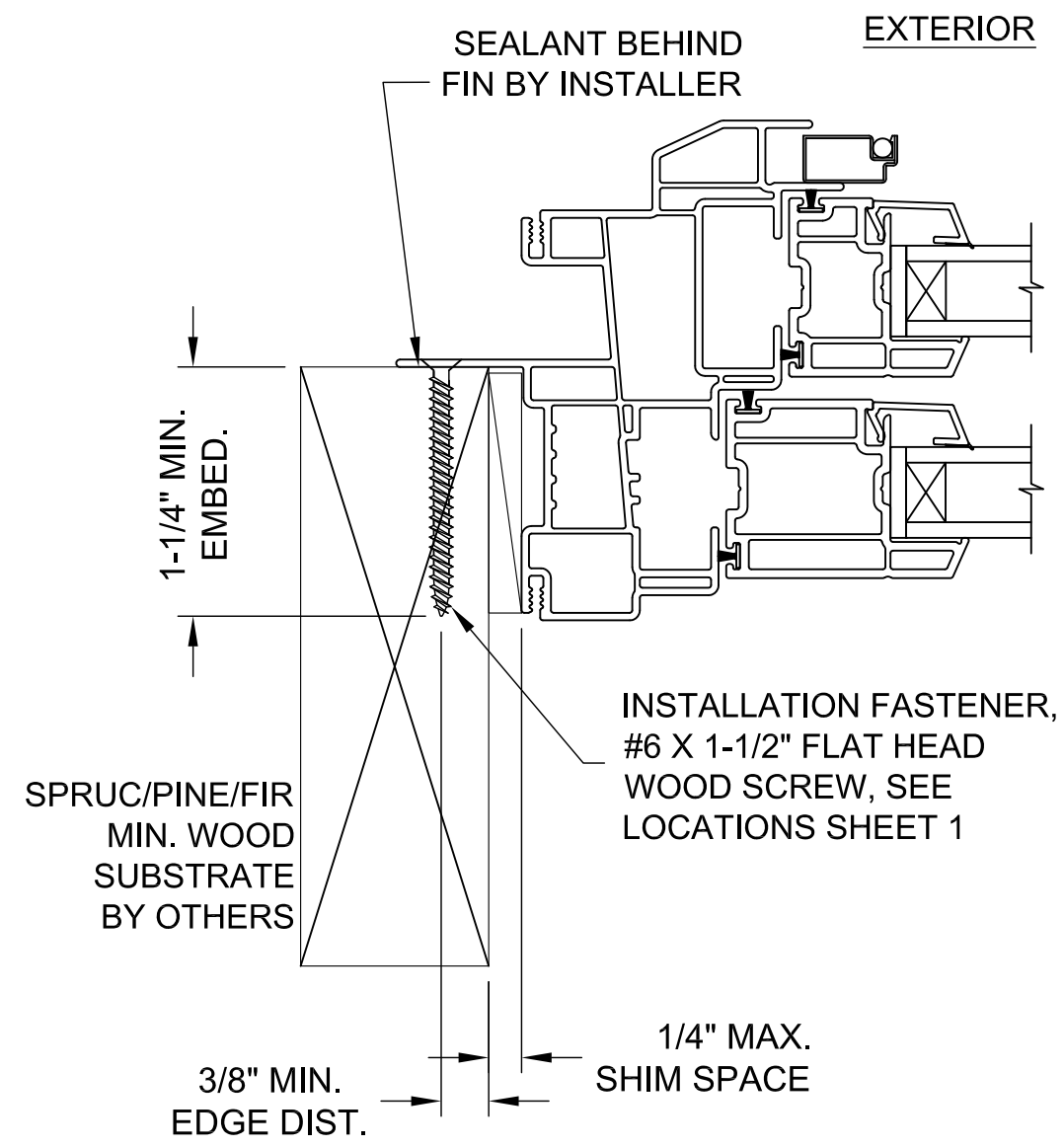

**TYPICAL JAMB HORIZONTAL SECTION**

<b>NORTHEAST BUILDING PRODUCTS</b> 4280 Aramingo Ave., Philadelphia, PA 19124 Ph. (215) 535-7110 www.camelotwindows.com	
SHEET DESCRIPTION: NEW CONSTR. INSTALLATION	DATE DRAWN: 2/7/2020
SCALE: NTS	REV: 0
DRAWING: TDI-INSPIRA-DH-NI	SHEET: 3 OF 3



11/12/2020  
 Lucas A. Turner, P.E.  
 TX PE #115094  
 2428 Old Natchez Trc Trl  
 Camden, TN 38320  
 Ph. 941-380-1574