

1
2 **HORIZONTAL CROSS SECTION**

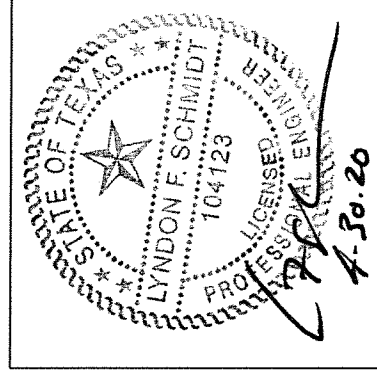

Documents Prepared By: Lyndon F. Schmidt, P.E.
TEXAS P.E. #104123

RW BUILDING CONSULTANTS, INC.
P.O. Box 230 Valrico FL 33595
Phone No.: 813.659.9197

TEXAS BOARD OF PROFESSIONAL ENGINEERS
CERTIFICATE OF REGISTRATION # F-11852

PRODUCT: NewSouth	
PART OR ASSEMBLY: HORIZONTAL CROSS SECTIONS	
NO.	DATE
BY	REVISIONS
DATE: 3/11/20	
SCALE: N.T.S.	
DWG. BY: RW	
CHK. BY: LFS	
DRAWING NO.: TX-4998	
SHEET 2 OF 4	

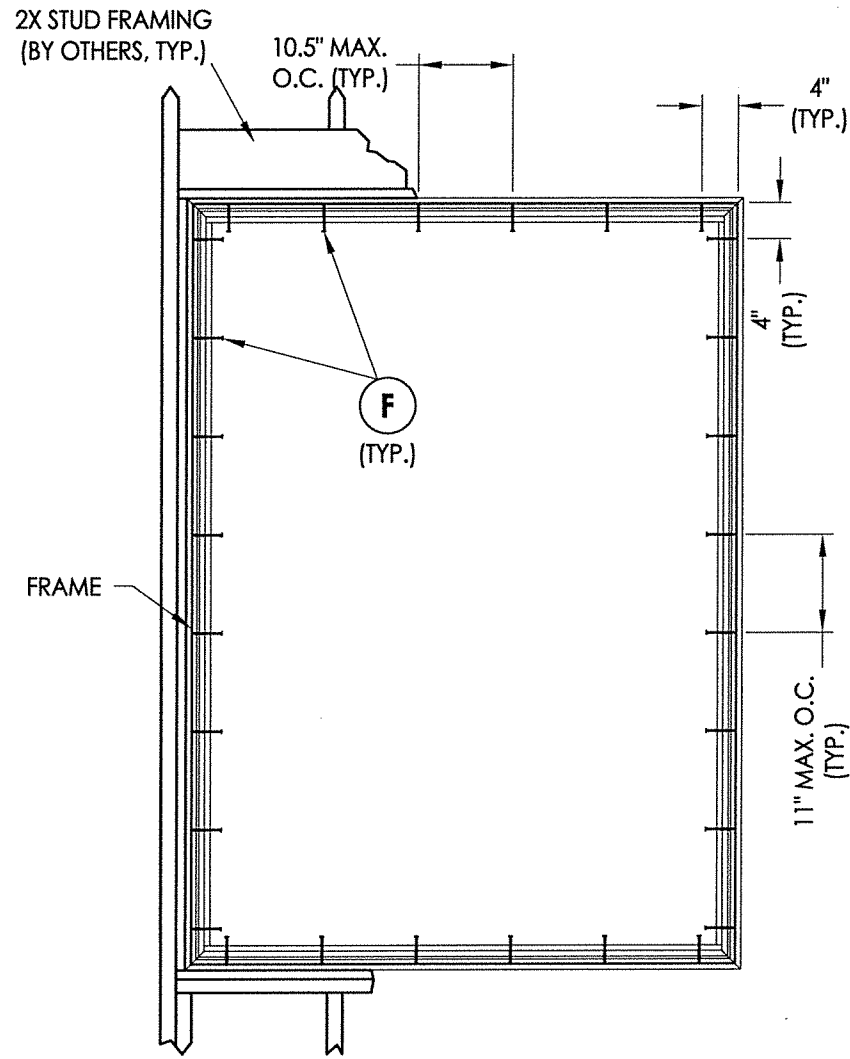

FRAME ANCHORING
60" x 84" MAX. FRAME SIZE

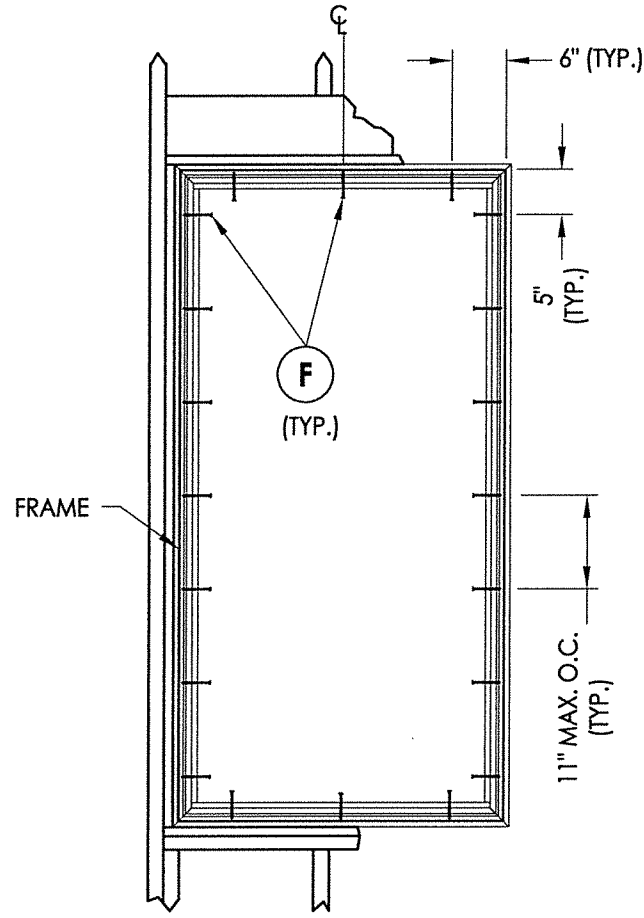

FRAME ANCHORING
36" x 72" MAX. FRAME SIZE

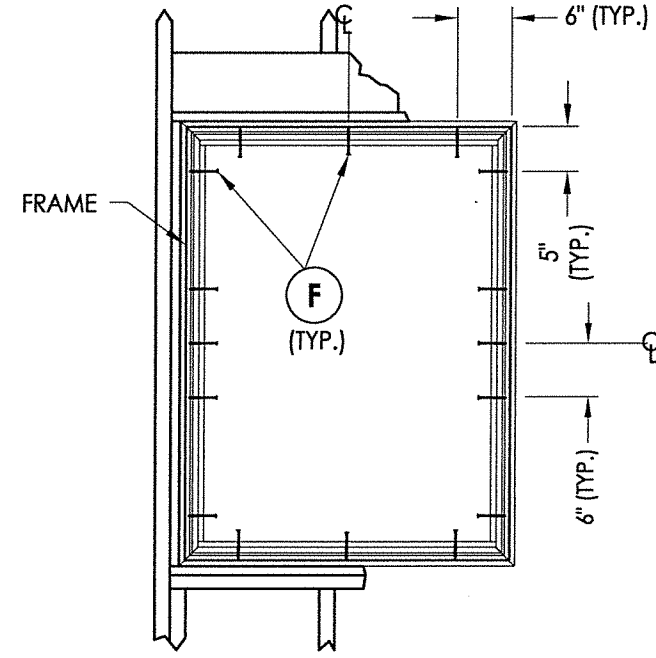

FRAME ANCHORING
36" x 48" MAX. FRAME SIZE



Documents Prepared By: Lyndon F. Schmidt, P.E.
TEXAS P.E. #104123

RW BUILDING CONSULTANTS, INC.
P.O. Box 230 Valrico FL, 33595
Phone No.: 813.659.9197
TEXAS BOARD OF PROFESSIONAL ENGINEERS
CERTIFICATE OF REGISTRATION # F-11852

PRODUCT: NewSouth
PART OR ASSEMBLY: FRAME ANCHORING

NO.	DATE	BY

DATE: 3/11/20
SCALE: N.T.S.
DWG. BY: RW
CHK. BY: LFS
DRAWING NO.: TX-4998
SHEET 3 OF 4

BILL OF MATERIALS

ITEM #	DESCRIPTION	MATERIAL
B	2X FRAMING (SG >= 0.42)	WOOD
C	1/4" MAX. SHIM SPACE	-
F	#10 X 2" PPH SMS (1-1/8" MIN. EMBEDMENT)	STEEL
1	EXTRUDED VINYL FRAME (437)*	RIGID PVC
2	EXTRUDED VINYL GLAZING BEAD (736A)*	RIGID PVC
12	FRAME ADAPTER	RIGID PVC

* THE APPROVED WHITE RIGID PVC EXTERIOR EXTRUSIONS FOR WINDOWS ARE TO BE PRODUCED BY EXTRUDERS LICENSEES IN "CERTIFICATION PROGRAMS FOR RIGID PVC EXTRUSIONS".

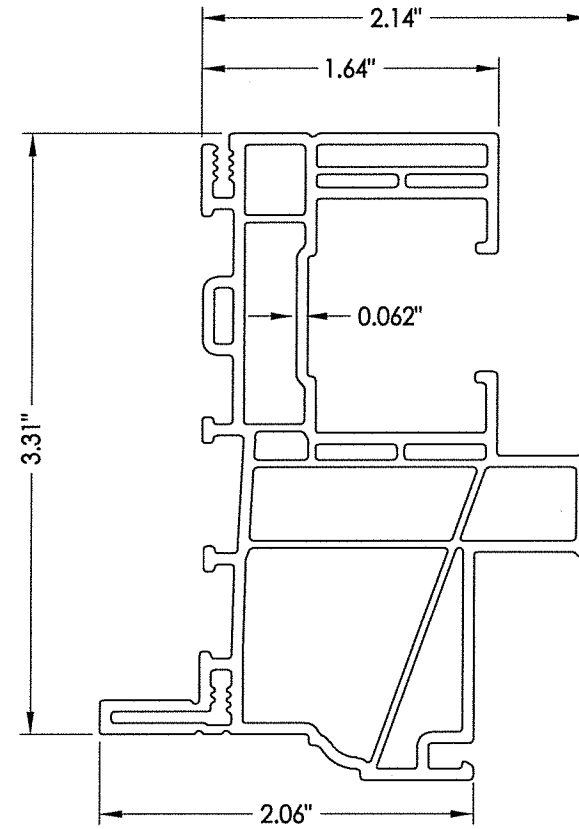

1 FRAME

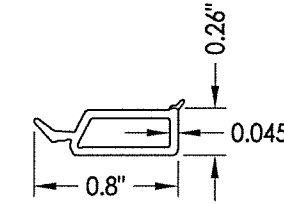

2 GLAZING BEAD

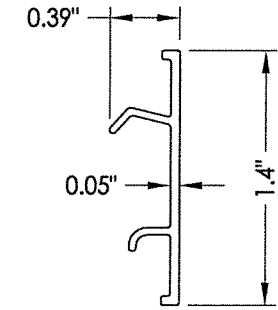

12 FRAME ADAPTER

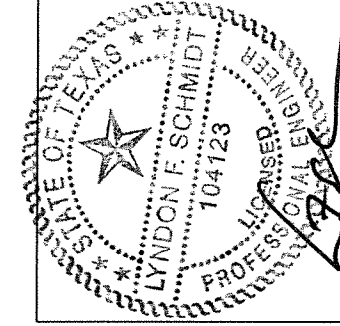

Documents Prepared By: Lyndon F. Schmidt, P.E.
TEXAS P.E. #104123

RW BUILDING CONSULTANTS, INC.
P.O. Box 230 Valrico FL 33595
Phone No.: 813.659.9197

TEXAS BOARD OF PROFESSIONAL ENGINEERS
CERTIFICATE OF REGISTRATION # F-11852

PRODUCT:	NewSouth
PART OR ASSEMBLY:	BILL OF MATERIALS, COMPONENTS & GLAZING DETAILS

NO.	DATE	BY	REVISIONS

DATE:	3/11/20
SCALE:	N.T.S.
DWG. BY:	RW
CHK. BY:	LFS
DRAWING NO.:	TX-4998
SHEET	4 OF 4

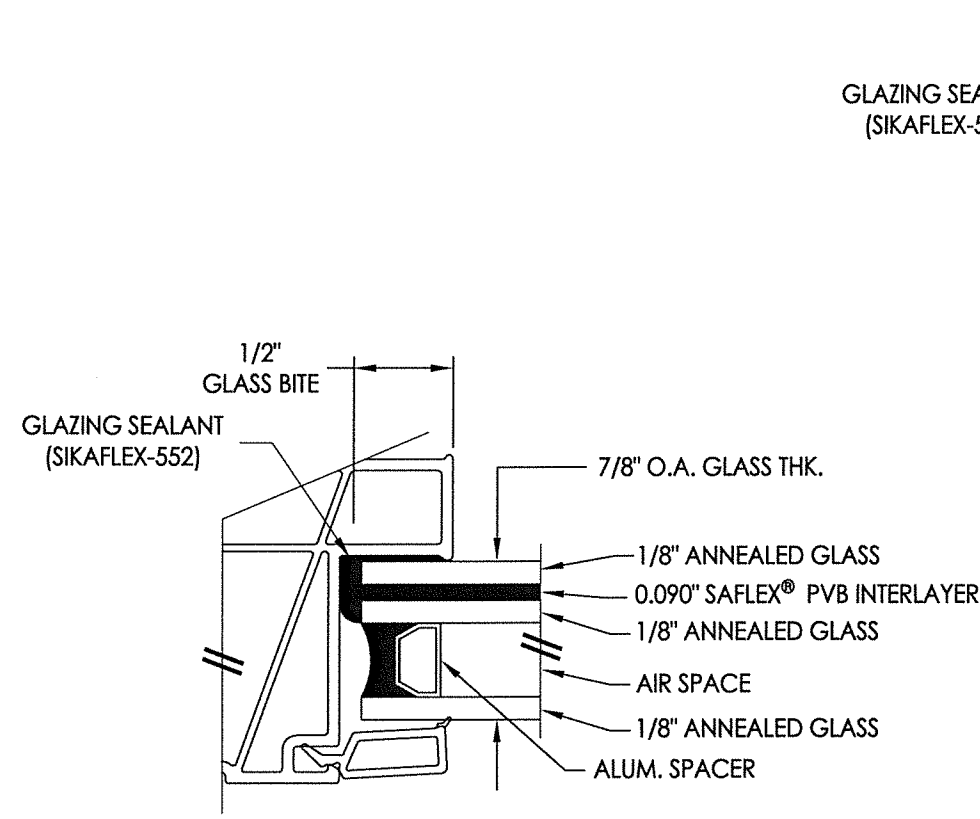

G1 GLAZING DETAIL

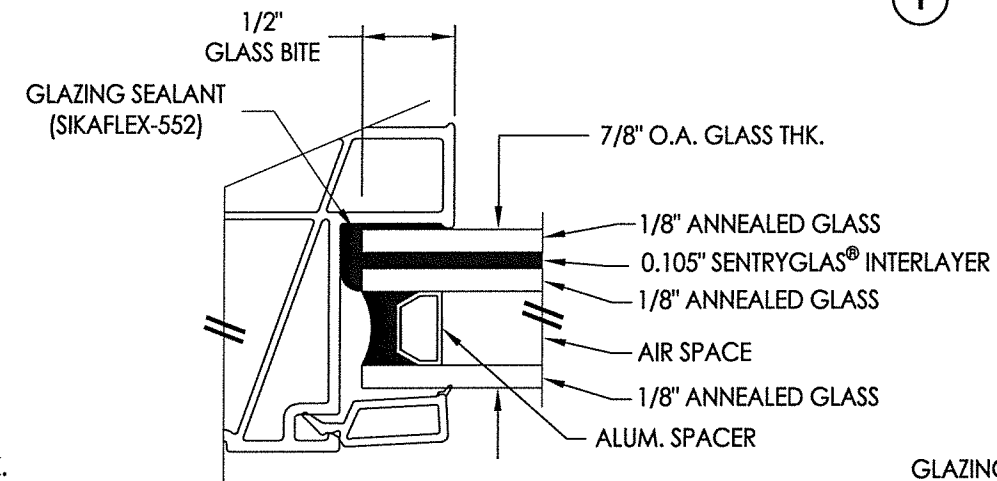

G2 GLAZING DETAIL

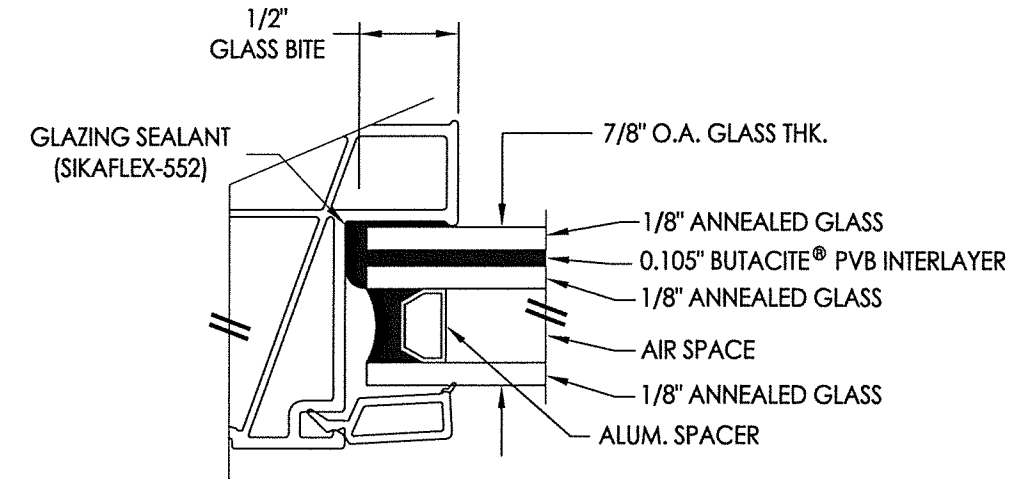

G3 GLAZING DETAIL