

TYPICAL ELEVATION WITH FASTENER SPACING

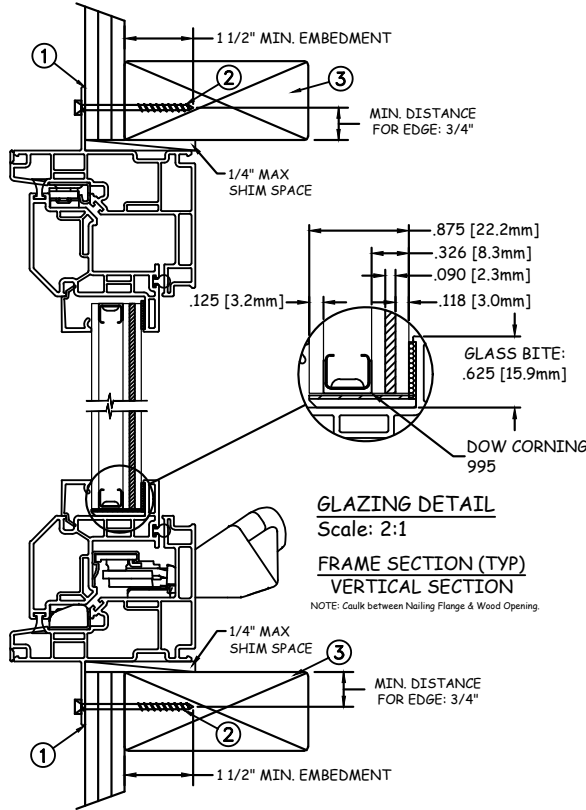

GLAZING DETAIL
Scale: 2:1
FRAME SECTION (TYP)
VERTICAL SECTION
NOTE: Caulk between Nailing Flange & Wood Opening.

NAIL FIN INSTALLATION

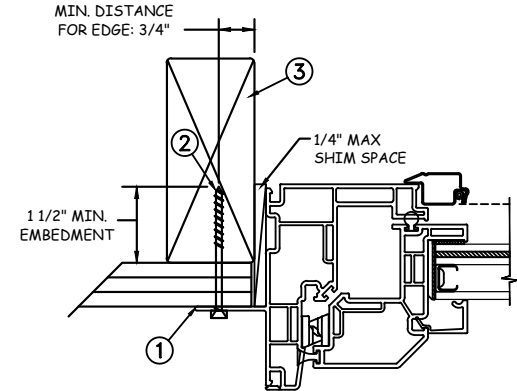

JAMB SECTION (TYP)
HORIZONTAL SECTION

NOTE: Caulk between Nailing Flange & Wood Opening.

Max Frame	DP RATING	IMPACT
108 x 72	+50/-55	YES

WINDZONE 3

Installation Notes:

1. Seal flange/frame to substrate.
2. Use #8 PH or greater fastener through the nail fin with sufficient length to penetrate a minimum of 1 1/2" into the wood framing. For 2X wood frame substrate (min. S.G. = 0.42).
3. Host structure (wood buck, masonry, steel) to be designed and anchored to properly transfer all loads to the structure. The host structure is the responsibility of the architect or engineer of record for the project of installation.

General Notes:

1. The product shown herein is designed, tested and manufactured to comply with the wind load criteria of the adopted 2018 International Building Code (IBC), the 2018 International Residential Code (IRC), the Texas Revisions and the industry requirement for the stated conditions.
2. All glazing shall conform to ASTM E1300.
3. At minimum, glazing shall be 3.2mm annealed - 10.8mm airspace - 3.0mm annealed - 2.3mm PVB Interlayer by Kurraray - 3.0mm annealed insulated glass.
4. Use structural or composite shims where required.

This schedule addresses only the fasteners required to anchor the window to achieve the rated design pressure up to the size limitations noted. It is not intended as a guide to the installation process and does not address the sealing consideration that may arise in different wall conditions. For the complete installation procedure, see the instructions packaged with the window or go to www.jeld-wen.com.

DISCLAIMER:

This drawing and its contents are confidential and are not to be reproduced or copied in whole or in part or used or disclosed to others except as authorized by JELD-WEN Inc.



Joseph A. Reed

2020.11.12 16:06:52 -05'00'

JOSEPH A. REED, P.E.

Texas No. 100777
5 Leigh Drive
York, PA. 17406
(717) 846-1200

PROJECT ENGINEER: --	DATE: 11/05/20
DRAWN BY: A. MCMILLAN	SCALE: NTS
CHECKED BY: J. GOOSSEN	TITLE: Premium Vinyl Casement Impact Window XXX - WZ3
APPROVED BY: J. GOOSSEN	
PART/PROJECT No.: D014631	
IDENTIFIER No. NCTL-110-17-025	PLANT NAME AND LOCATION:

JELD-WEN

3737 Lakeport Blvd
Klamath Falls, OR. 97601
Phone: (800) 535-3936

CAD DWG. No.: PremVinylCsmnt Cert	REV: B	SHEET 1 OF 4
--------------------------------------	-----------	-----------------

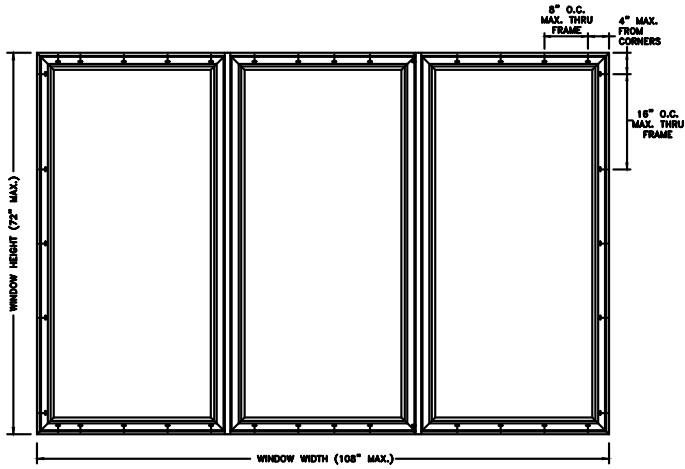

TYPICAL ELEVATION WITH FASTENER SPACING

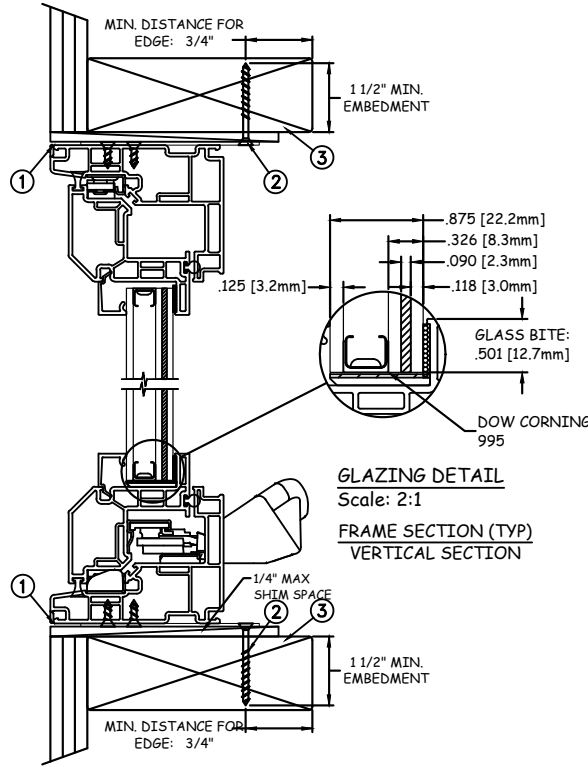

GLAZING DETAIL

Scale: 2:1

FRAME SECTION (TYP)

VERTICAL SECTION

MASONRY STRAP INSTALLATION

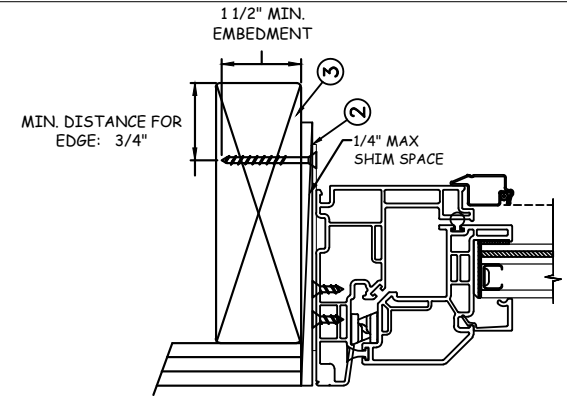

JAMB SECTION (TYP)
HORIZONTAL SECTION

Max Frame	DP RATING	IMPACT
108 x 72	+50/-55	YES

WINDZONE 3

Installation Notes:

1. Seal flange/frame to substrate.
2. Use #8 PH or greater fastener through the frame with sufficient length to penetrate a minimum of 1 1/2" into the wood framing. For 2X wood frame substrate (min. S.G. = 0.42).
3. Host structure (wood buck, masonry, steel) to be designed and anchored to properly transfer all loads to the structure. The host structure is the responsibility of the architect or engineer of record for the project of installation.

General Notes:

1. The product shown herein is designed, tested and manufactured to comply with the wind load criteria of the adopted 2018 International Building Code (IBC), the 2018 International Residential Code (IRC), the Texas Revisions and the industry requirement for the stated conditions.
2. All glazing shall conform to ASTM E1300.
3. At minimum, glazing shall be 3.0mm annealed - 12.7mm airspace - 3.0mm annealed - .76mm PVB Interlayer by Kurraray - 3.0mm annealed insulating glass.
4. Use structural or composite shims where required.

This schedule addresses only the fasteners required to anchor the window to achieve the rated design pressure up to the size limitations noted. It is not intended as a guide to the installation process and does not address the sealing consideration that may arise in different wall conditions. For the complete installation procedure, see the instructions packaged with the window or go to www.jeld-wen.com.

DISCLAIMER:

This drawing and its contents are confidential and are not to be reproduced or copied in whole or in part or used or disclosed to others except as authorized by JELD-WEN Inc.



Joseph A. Reed

2020.11.12 16:06:52 -05'00'

JOSEPH A. REED, P.E.

Texas No. 100777
5 Leigh Drive
York, PA. 17406
(717) 846-1200

PROJECT ENGINEER: --	DATE: 11/05/20
DRAWN BY: A. MCMILLAN	SCALE: NTS
CHECKED BY: J. GOOSSEN	TITLE: Premium Vinyl Casement Impact Window XXX - WZ3
APPROVED BY: J. GOOSSEN	
PART/PROJECT No.: D014631	
IDENTIFIER No. NCTL-110-17-025	PLANT NAME AND LOCATION:

JELD-WEN

3737 Lakeport Blvd
Klamath Falls, OR. 97601
Phone: (800) 535-3936

CAD DWG. No.: PremVinyl/Csmt Cert	REV: B	SHEET 2 OF 4
--------------------------------------	-----------	-----------------

MASONRY INSTALLATION

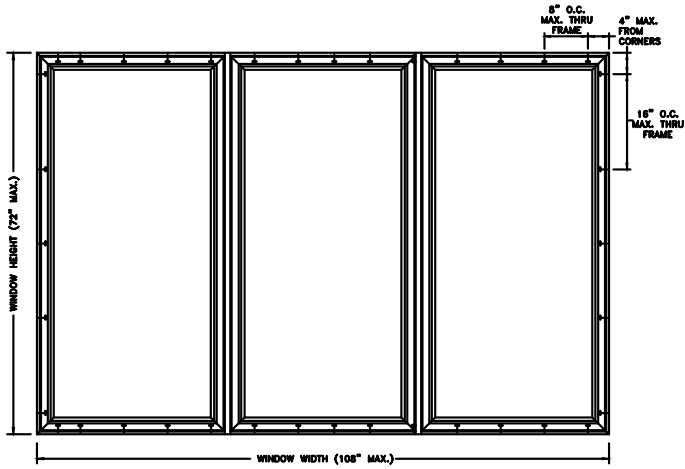

TYPICAL ELEVATION WITH FASTENER SPACING

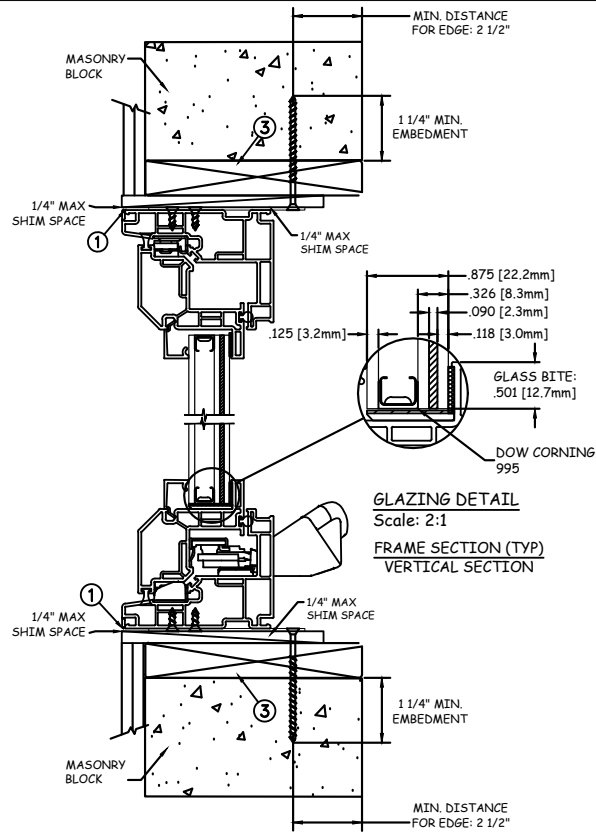

GLAZING DETAIL
Scale: 2:1
FRAME SECTION (TYP)
VERTICAL SECTION

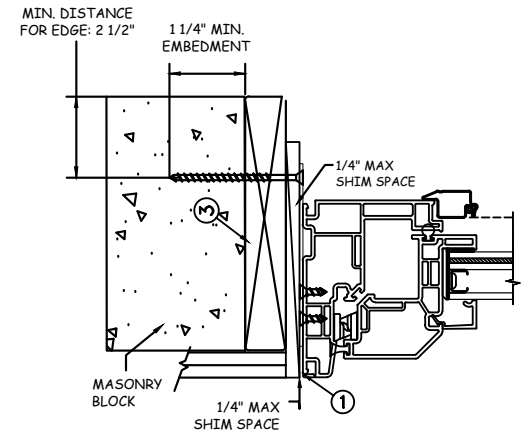

JAMB SECTION (TYP)
HORIZONTAL SECTION

Max Frame	DP RATING	IMPACT
108 x 72	+50/-55	YES

WINDZONE 3

Installation Notes:

1. Seal flange/frame to substrate.
2. Use 3/16" Tapcon or equivalent fasteners through frame with sufficient length to penetrate a minimum of 1 1/4" into concrete or masonry at each location with a 2 1/2" min from edge distance. For concrete (min. = 3000psi) or masonry (min. = 2000psi) (CMU shall conform to ASTM C90).
3. Host structure (wood buck, masonry, steel) to be designed and anchored to properly transfer all loads to the structure. The host structure is the responsibility of the architect or engineer of record for the project of installation.

General Notes:

1. The product shown herein is designed, tested and manufactured to comply with the wind load criteria of the adopted 2018 International Building Code (IBC), the 2018 International Residential Code (IRC), the Texas Revisions and the industry requirement for the stated conditions.
2. All glazing shall conform to ASTM E1300.
3. At minimum, glazing shall be 3.0mm annealed - 12.7mm airspace - 3.0mm annealed - .76mm PVB Interlayer by Kurraray - 3.0mm annealed insulating glass.
4. Use structural or composite shims where required.

This schedule addresses only the fasteners required to anchor the window to achieve the rated design pressure up to the size limitations noted. It is not intended as a guide to the installation process and does not address the sealing consideration that may arise in different wall conditions. For the complete installation procedure, see the instructions packaged with the window or go to www.jeld-wen.com.

DISCLAIMER:

This drawing and its contents are confidential and are not to be reproduced or copied in whole or in part or used or disclosed to others except as authorized by JELD-WEN Inc.



Joseph A. Reed

2020.11.12 16:06:52 -05'00'

JOSEPH A. REED, P.E.

Texas No. 100777
5 Leigh Drive
York, PA. 17406
(717) 846-1200

PROJECT ENGINEER: --	DATE: 11/05/20
DRAWN BY: A. MCMILLAN	SCALE: NTS
CHECKED BY: J. GOOSSEN	TITLE: Premium Vinyl Casement Impact Window XXX - WZ3
APPROVED BY: J. GOOSSEN	
PART/PROJECT No.: D014631	
IDENTIFIER No. NCTL-110-17-025	PLANT NAME AND LOCATION:

JELD-WEN

3737 Lakeport Blvd
Klamath Falls, OR. 97601
Phone: (800) 535-3936

CAD DWG. No.: PremVinyl/Csmt Cert	REV: B	SHEET 3 OF 4
--------------------------------------	-----------	-----------------

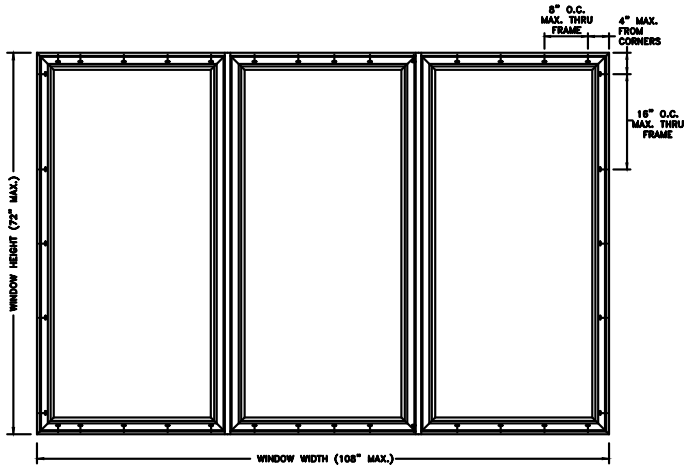

TYPICAL ELEVATION WITH FASTENER SPACING

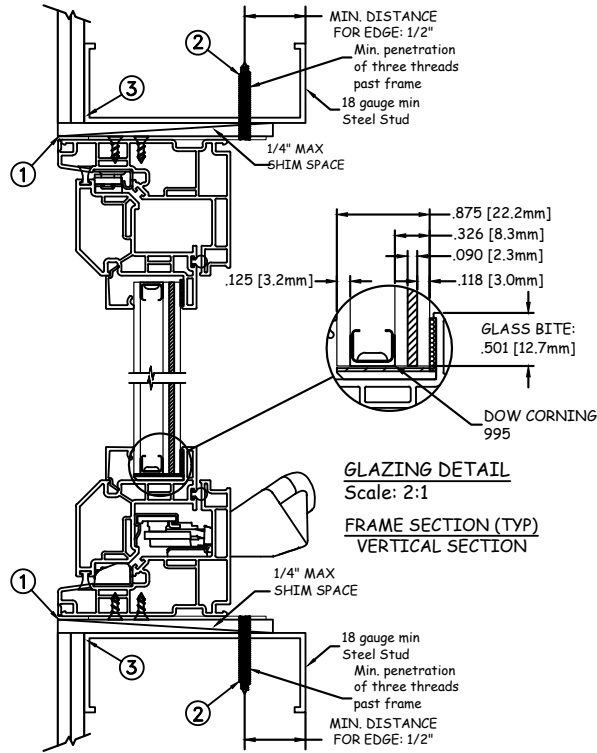

GLAZING DETAIL
Scale: 2:1
FRAME SECTION (TYP)
VERTICAL SECTION

STEEL INSTALLATION

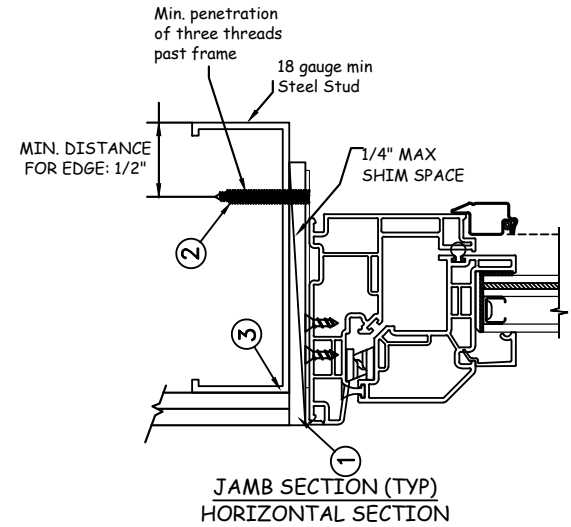

Max Frame	DP RATING	IMPACT
108 x 72	+50/-55	YES

WINDZONE 3

Installation Notes:

1. Seal flange/frame to substrate.
2. For anchoring into metal framing, use #8 TEK Self Tapping screws with sufficient length to achieve a minimum penetration of three threads past the frame thickness. Locate anchors as shown in elevations and installation details. Steel substrate min. 18ga., fy = 33 ksi.
3. Host structure (wood buck, masonry, steel) to be designed and anchored to properly transfer all loads to the structure. The host structure is the responsibility of the architect or engineer of record for the project of installation.

General Notes:

1. The product shown herein is designed, tested and manufactured to comply with the wind load criteria of the adopted 2018 International Building Code (IBC), the 2018 International Residential Code (IRC), the Texas Revisions and the industry requirement for the stated conditions.
2. All glazing shall conform to ASTM E1300.
3. At minimum, glazing shall be 3.0mm annealed - 12.7mm airspace - 3.0mm annealed - .76mm PVB Interlayer by Kurraray - 3.0mm annealed insulating glass.
4. Use structural or composite shims where required.

This schedule addresses only the fasteners required to anchor the window to achieve the rated design pressure up to the size limitations noted. It is not intended as a guide to the installation process and does not address the sealing consideration that may arise in different wall conditions. For the complete installation procedure, see the instructions packaged with the window or go to www.jeld-wen.com.

DISCLAIMER:

This drawing and its contents are confidential and are not to be reproduced or copied in whole or in part or used or disclosed to others except as authorized by JELD-WEN Inc.



Joseph A. Reed

2020.11.12 16:06:52 -05'00'

JOSEPH A. REED, P.E.

Texas No. 100777
5 Leigh Drive
York, PA. 17406
(717) 846-1200

PROJECT ENGINEER: --	DATE: 11/05/20
DRAWN BY: A. MCMILLAN	SCALE: NTS
CHECKED BY: J. GOOSSEN	TITLE: Premium Vinyl Casement Impact Window XXX - WZ3
APPROVED BY: J. GOOSSEN	
PART/PROJECT No.: D014631	
IDENTIFIER No. NCTL-110-17-025	PLANT NAME AND LOCATION:



3737 Lakeport Blvd
Klamath Falls, OR. 97601
Phone: (800) 535-3936

CAD DWG. No.: PremVinyl/Csmt Cert	REV: B	SHEET 4 OF 4
--------------------------------------	-----------	-----------------