

MODEL 8100 SYSTEM 5 SINGLE HUNG - LARGE MISSILE IMPACT

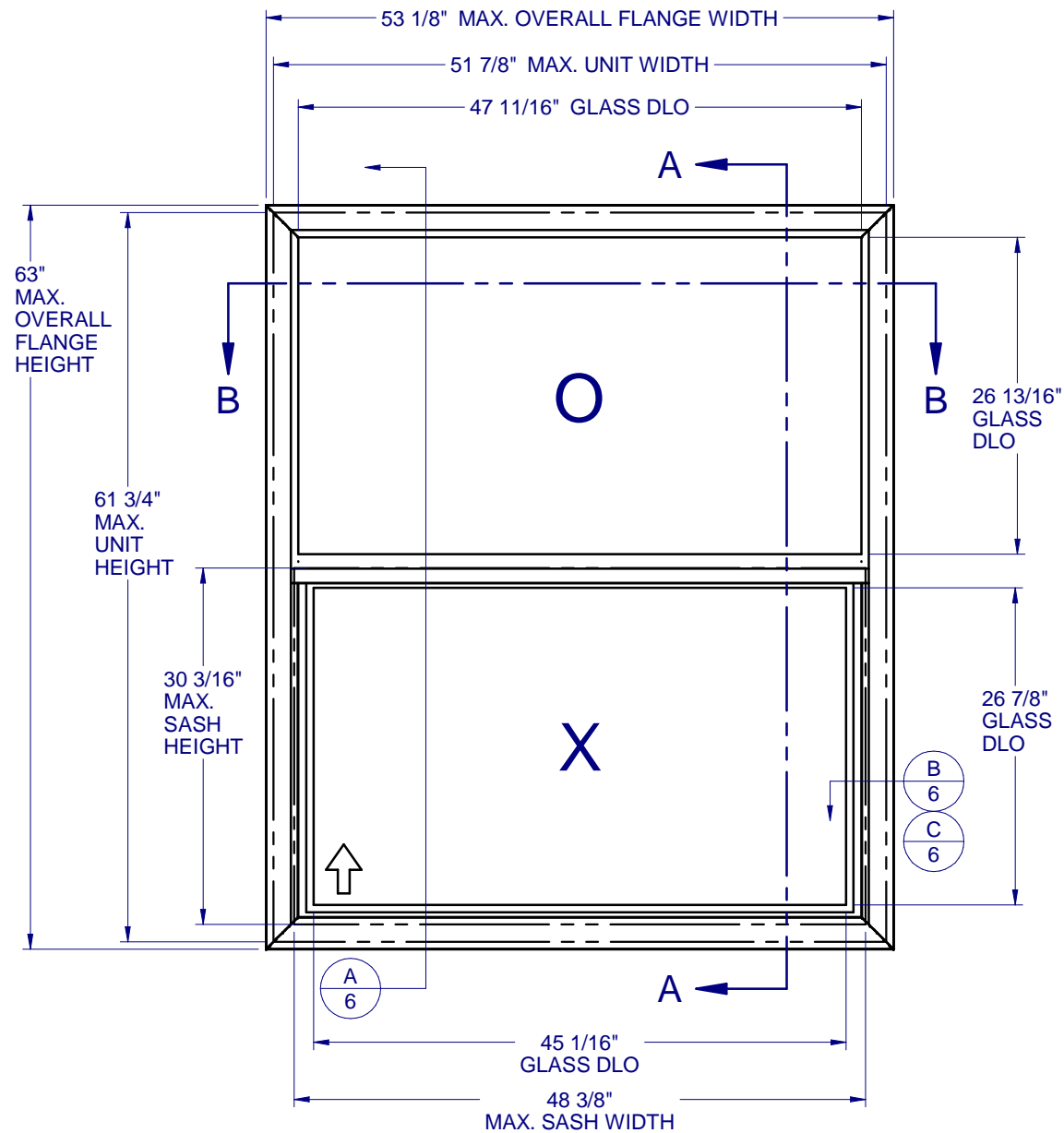

SYSTEM 5
(CAR 138-510/138-1047)

TABLE OF CONTENTS

GENERAL NOTES & ELEVATIONS.....	1
GLAZING DETAIL.....	2
SECTION VIEWS.....	3
EXTRUSIONS & B.O.M.....	4
ANCHOR SCHEDULE & NOTES.....	5
INSTALLATION DETAILS.....	6

GENERAL NOTES:

1. THE PRODUCT SHOWN HEREIN IS DESIGNED AND MANUFACTURED TO COMPLY WITH THE REQUIREMENTS OF THE INTERNATIONAL BUILDING CODE (IBC) AND INTERNATIONAL RESIDENTIAL CODE (IRC), WITH TEXAS REVISIONS EFFECTIVE JANUARY 1, 2008.
2. GLAZING OPTIONS: (SEE SHEET 2)
3. CONFIGURATIONS: "O/X".
4. ANCHORAGE: THE 33 1/3% STRESS INCREASE HAS NOT BEEN USED IN THE DESIGN OF THIS PRODUCT. SEE SHEET 6 FOR ANCHOR DETAILS. WINDLOAD DURATION FACTOR Cd=1.6 WAS USED FOR WOOD ANCHOR CALCULATIONS.
5. PRODUCT APPROVED FOR IMPACT RESISTANCE. SHUTTERS ARE NOT REQUIRED.
6. ALL FRAMES AND VENTS FULLY WELDED. SMALL JOINT SEAM SEALANT USED AT FIXED MEETING RAIL AND JAMB.
7. SERIES / MODEL DESIGNATION SH-8100.
8. THE DESIGNATION X AND O STAND FOR THE FOLLOWING:
X = OPERABLE SASH, O = FIXED SASH
9. SECTION CALLOUTS APPLY TO ALL ELEVATIONS IN A SIMILAR LOCATION.
10. EXTERNAL WEEP SLOT = 1/4" x 1-1/4" LOCATED 4" FROM BOTH ENDS.

Custom
WINDOW SYSTEMS
1900 SW 44TH AVE.
OCALA, FLORIDA 34474
WWW.CWS.CC

8100 PVC SINGLE HUNG IMPACT

NO.:	DESCRIPTION:	BY:	DATE:

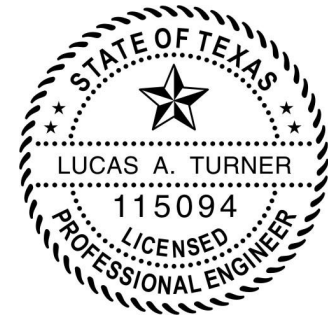

27
9/29/2016

LUCAS A. TURNER, P.E.
TX PE # 115094
1239 JABARA AVE.
NORTH PORT, FL 34288
PH. 941-380-1574

SHEET DESCRIPTION:
GENERAL NOTES AND ELEVATIONS

DRAWN BY:	DATE:
EMK	11/12/15
DWG #:	REV.:
TDI-812	-
SCALE:	SHEET
1:15	1 OF 6

**8100 PVC
SINGLE HUNG
IMPACT**

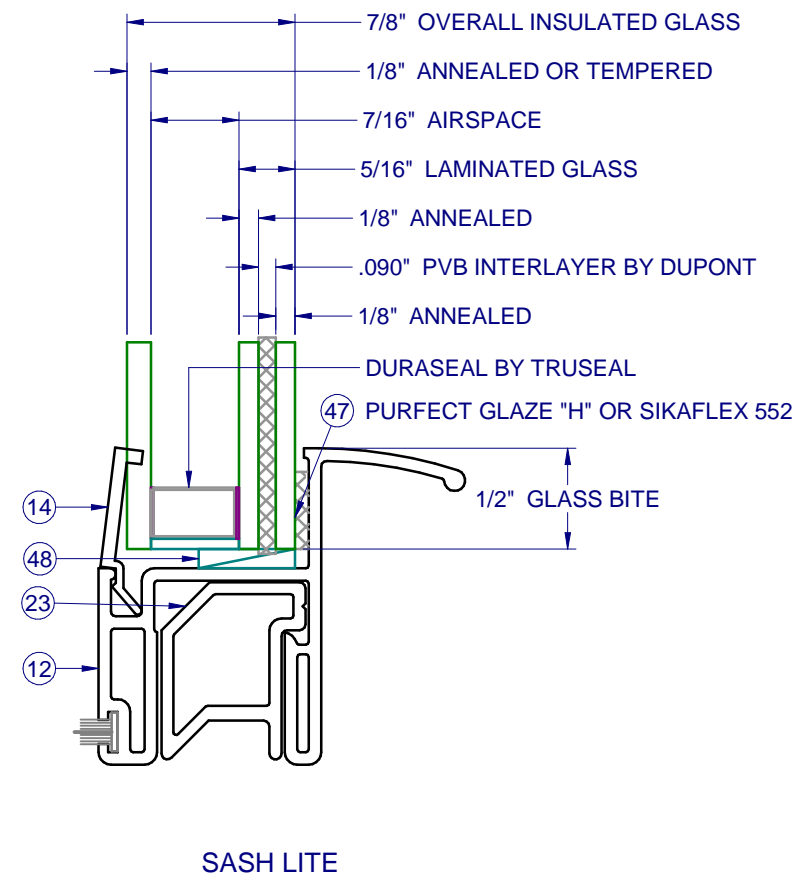
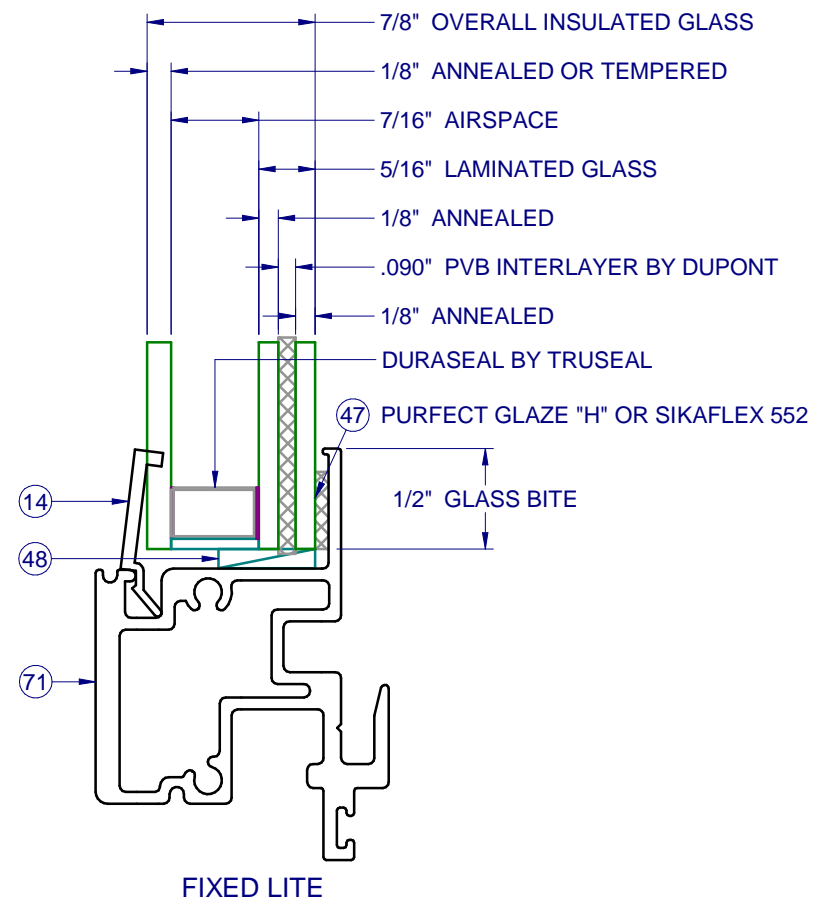

NO.	DESCRIPTION	BY	DATE

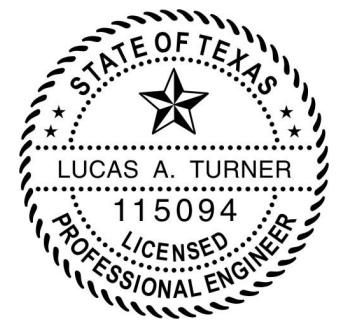

ZZ

9/29/2016

LUCAS A. TURNER, P.E.
TX PE # 115094
1239 JABARA AVE.
NORTH PORT, FL 34288
PH. 941-380-1574

SHEET DESCRIPTION:

GLAZING DETAILS

DRAWN BY: EMK	DATE: 11/12/15
DWG #: TDI-812	REV.: -
SCALE: 1:1	SHEET 2 OF 6

8100 PVC SINGLE HUNG IMPACT

NO.	DESCRIPTION:	BY:	DATE:

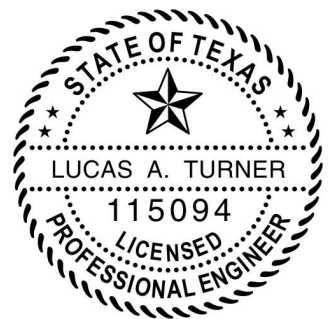

LT
9/29/2016

LUCAS A. TURNER, P.E.
TX PE # 115094
1239 JABARA AVE.
NORTH PORT, FL 34288
PH. 941-380-1574

SHEET DESCRIPTION:

SECTION VIEWS

DRAWN BY:	DATE:
EMK	11/12/15
DWG #:	REV.:
TDI-812	-
SCALE:	SHEET
1:2	3 OF 6

INTERIOR

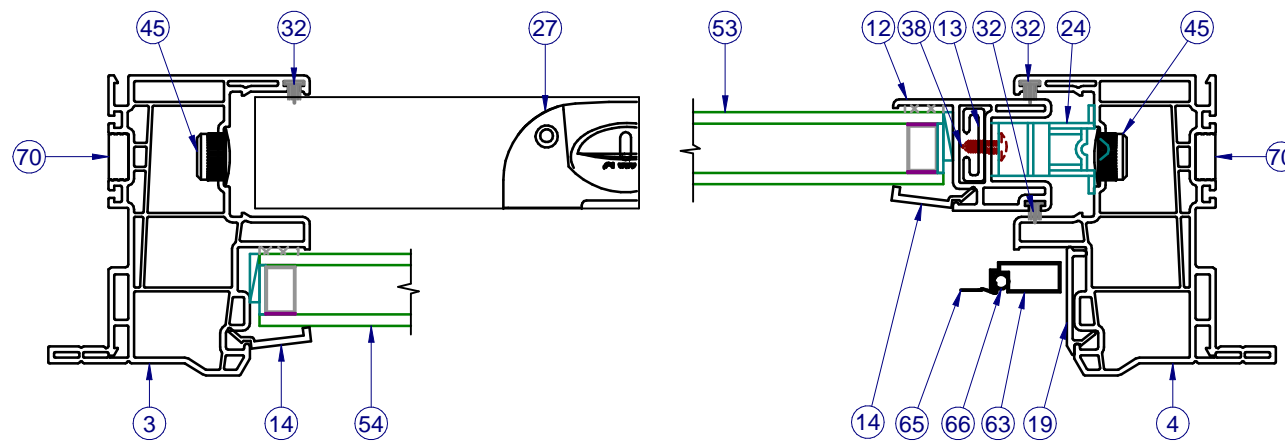

SECTION B-B

NOTE: LEFT SIDE SHOWS FIXED SECTION VIEW, RIGHT SIDE SHOWS SASH SECTION VIEW.

INTERIOR

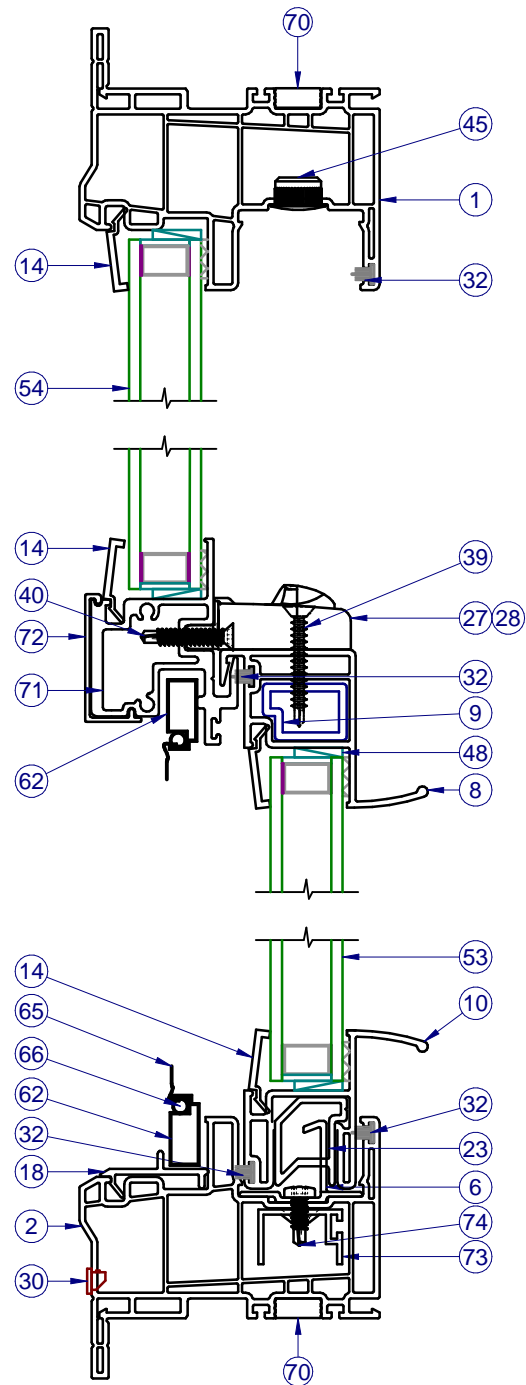

SECTION A-A

NOTE: ITEMS NOT SHOWN FOR CLARITY:
20, 25-26, 36-37, 44, 51-52, 55-56, 64, 67-68

PARTS LIST				
ITEM	PART #	DESCRIPTION	VENDOR	MATERIAL
1	H-6031	Main Fr., SH, w/Flg., PVC, Head	Mikron	Vinyl
2	H-6031	Main Fr., SH, w/Flg., PVC, Sill	Mikron	Vinyl
3	H-6031	Main Fr., SH, w/Flg., PVC, L. Jb.	Mikron	Vinyl
4	H-6031	Main Fr., SH, w/Flg., PVC, R. Jb.	Mikron	Vinyl
6	S-1577	Impact Hook	Keymark	Alum
8	H-6027	Sash Meet. Rail, PVC	Mikron	Vinyl
9	H-1497	Reinf. Sash Meet. Rail	Keymark	Alum
10	H-6028	Sash Bottom Rail, PVC	Mikron	Vinyl
12	H-6004	Sash Side/Top/Bot. Rail	Mikron	Vinyl
13	S-1498	Reinf. S.B.R./S.S.R		
14	S-6064	Glz. Bd., 7/8"	Mikron	Vinyl
18	S-6013	Scrn. Adapt., w/Nib, PVC, Horiz.	Mikron	Vinyl
19	S-6014	Scrn. Adapt., PVC, Vert.	Mikron	Vinyl
20	S-6029	Sash Stop / Filler, PVC, Vert.	Mikron	Vinyl
23	H-1699	Reinforcement, SBR	Keymark	Alum
24	P-2190	Balance	BSI	
25	P-3059	Sash Cam, PVC	BSI	Plastic
26	P-3046	Take Out Clip	BSI	SS
27	P-3783	Lock, Impact, PVC	Interlock	
28	P-4069	Keeper, Impact, PVC	Interlock	Zamac
30	P-3215	Weep Cover w/ Flap	Gaer	Plastic
32	P-3429	Wstp., 0.270 x .187 back FinSeal, Gray	Ultrafab	
37	P-4638	#8 x 2-1/2 PH Mod. Truss, Type A, TEK 2	Fastenal	Steel
38	P-3768	#8 x 0.625 Ph PH SMS	Hub City	Steel
39	P-4051W	#8 x 1.250 Ph FH TEK, Wht.	Hub City	Steel
40	P-4264W	#8 x 3/4 FH PH w/#6 Head, TEK, Wht.	Hub City	Steel
44	P-3342	Seam Sealer, SM-5504	Schnee	
45	P-3752	Cap Plug, 1/2" Hole	M&M	Nylon
47	P-3438	Sikaflex 552 or Purfect Glaze "H"	Sika/Henkel	
48	P-3352	Set. Blk., 85 Dur., 1/8" x 5/8" x 2" Lg.	F. Lowe	Rubber
51	P-3881	Temporary Lbl. (NFRC/DP)		
52	P-3613	CWS Lbl. (logo)	Pro Label	
53	Sash	SEE SHEET 2	GLASS	
54	Fixed	SEE SHEET 2	GLASS	
56	P-3281	Spacer	Duraseal	
62	P-3218	Screen Frame, Horiz.	Allmetal	Alum
63	P-3218	Screen Frame, Vert.	Allmetal	Alum
64	P-3321	Screen Frame Corner Key	Allmetal	Plastic
65	P-3581	Screen Cloth, 18 x 16 Fiberglass	Bettervue	Fiberglass
66	P-3228	Screen Spline, .155 Dia., Blk.	Dapa	Vinyl
67	P-3029	Screen Pull Tab	Summit	Alum
68	P-3033	Screen Spring, SS	Fl. Screen	SS
70	P-3113	Screw Support for PVC	T. Plastics	Nylon
71	H-1836	Alum. Fixed Rail	Keymark	Alum
72	S-6063	Cover, Fixed Rail	Mikron	Vinyl
73	S-1112	Reinforcement, Impact Hook	Keymark	Alum
74	P-3541	#8 x 1/2", Pan Head, TEK	Fastenal	Steel

LINE ITEMS NOT USED:
5, 7, 11, 15-17, 21-22, 29, 31, 33-36, 41-43, 46, 49-50, 55, 57-61, 69

NOTE: ALL EXTRUSIONS ARE ALUMINUM 6063-T6 UNLESS OTHERWISE NOTED.

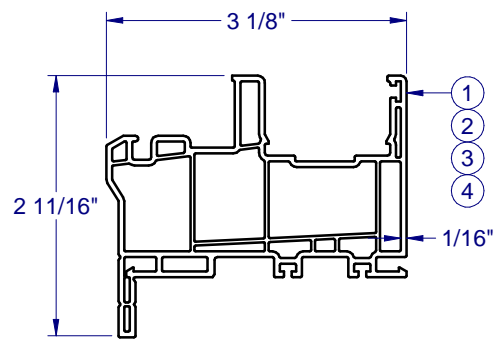

PVC FRAME FLANGE-6031

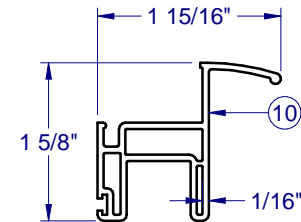

PVC SASH BTM. RAIL-6028

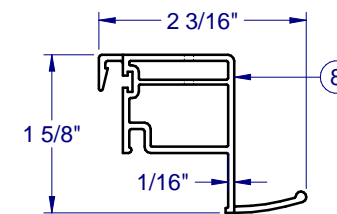

PVC SASH TOP RAIL-6027

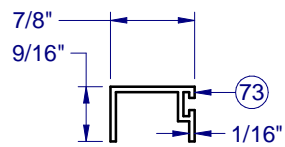

REINF., IMPACT HOOK - 1112

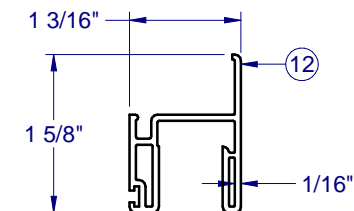

PVC SASH SIDE RAIL - 6004

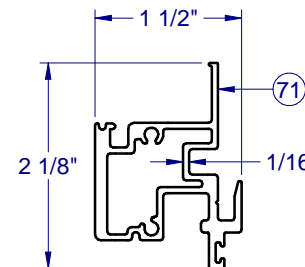

FIXED RAIL - 1836

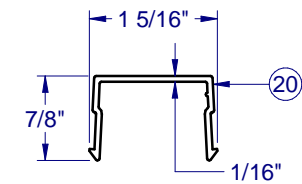

PVC SASH STOP - 6025

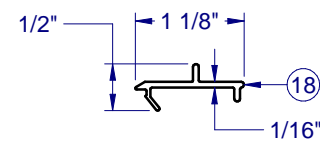

PVC SCREEN CATCH - 6013

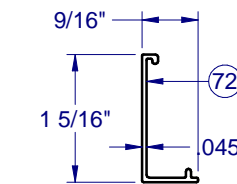

PVC FIXED RAIL COVER - 6063

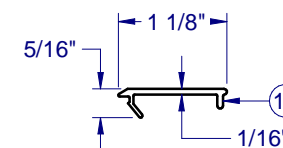

PVC SCREEN SUPPORT - 6014

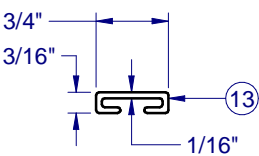

REINF. S.B.R./S.S.R. - 1498

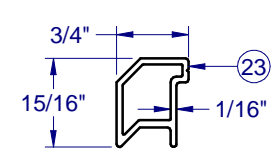

REINF. BTM RAIL-1699

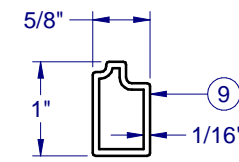

REINF. TOP RAIL-1497

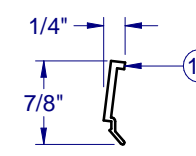

PVC GLAZING BEAD-6064

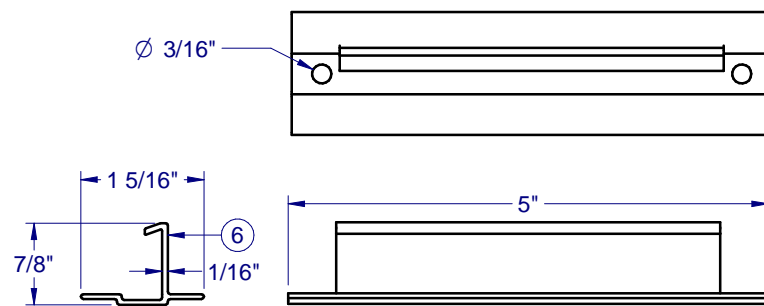

IMPACT HOOK
S-1577

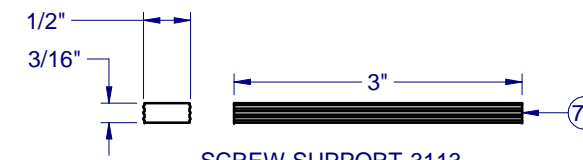

SCREW SUPPORT-3113

FRAME CORNER CONSTRUCTION

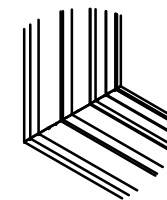

CORNER WELD
(ALL SIDES)
1:8

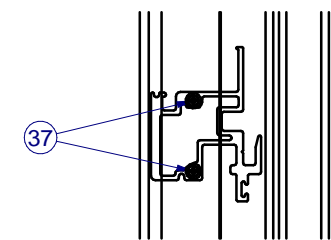

FIXED MEETING RAIL
SCREWED TOGETHER WITH
OUTERFRAME
1:8



1900 SW 44TH AVE.
OCALA, FLORIDA 34474
WWW.CWS.CC

8100 PVC SINGLE HUNG IMPACT

NO.	DESCRIPTION:	REVISIONS	BY:	DATE:

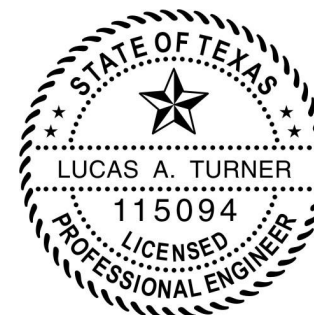

ZZ
9/29/2016

LUCAS A. TURNER, P.E.
TX PE # 115094
1239 JABARA AVE.
NORTH PORT, FL 34288
PH. 941-380-1574

SHEET DESCRIPTION:

BOM AND EXTRUSIONS

DRAWN BY:	DATE:
EMK	11/12/15
DWG #:	REV.:
TDI-812	-
SCALE:	SHEET
1:2	4 OF 6

**8100 PVC
SINGLE HUNG
IMPACT**

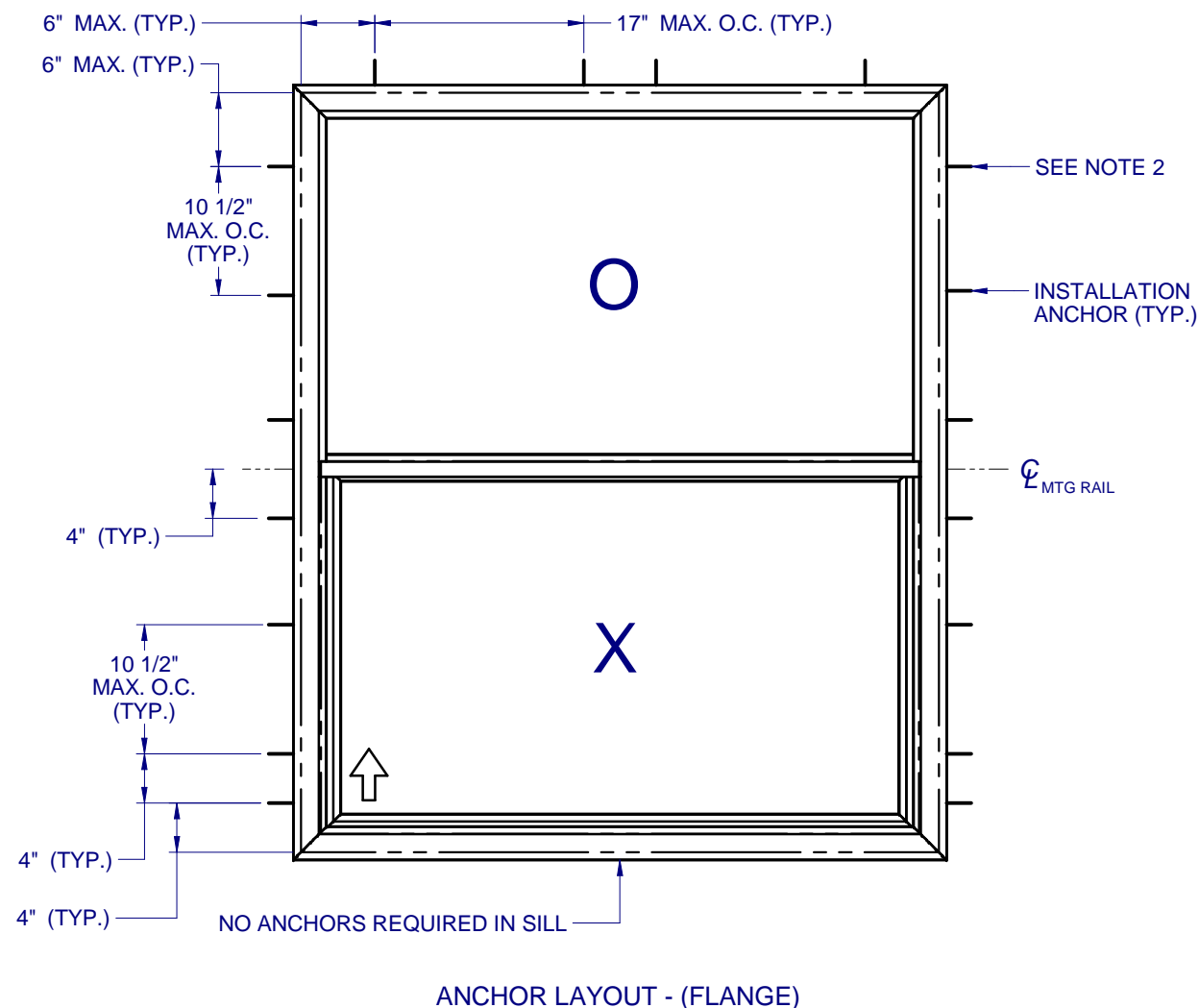

ANCHOR LAYOUT - (FLANGE)

NOTES:

1. INSTALL ONE ANCHOR AT EACH INSTALLATION LOCATION. NO ANCHORS REQUIRED IN SILL.
2. SHIM AS REQ AT EACH INSTALLATION ANCHOR USING LOAD BEARING SHIMS. MAX. ALLOWABLE SHIM STACK TO BE 1/4". USE SHIMS WHERE SPACE GREATER THAN 1/16" IS PRESENT. LOAD BEARING SHIMS SHALL BE CONSTRUCTED OF HIGH DENSITY PLASTIC OR BETTER. WOOD SHIMS ARE NOT ALLOWED.
3. ANCHOR TYPE, SIZE, SPACING AND EMBEDMENT SHALL BE AS SPECIFIED IN THESE DRAWINGS, SEE TABLE 1, SHEET 6.
4. ALL INSTALLATION ANCHORS MUST BE MADE OF OR PROTECTED WITH A CORROSION RESISTANT MATERIAL OR COATING. DISSIMILAR METALS OR MATERIALS IN CONTACT WITH PRESSURE TREATED WOOD MUST BE PROTECTED TO PREVENT REACTION.
5. INSTALLATION ANCHORS SHALL BE IN ACCORDANCE WITH ANCHOR MANUFACTURER'S INSTALLATION INSTRUCTIONS, AND ANCHORS SHALL NOT BE USED IN SUBSTRATES WITH STRENGTHS LESS THAN THE MINIMUM SPECIFIED IN TABLE 1, SHEET 6.
6. ANCHOR EMBEDMENT TO SUBSTRATE SHALL BE BEYOND WALL DRESSING OR STUCCO. FOR CONCRETE/CMU OPENINGS, EMBEDMENT SHALL BE BEYOND WOOD BUCKS, IF USED, INTO SUBSTRATE. INSTALLATIONS TO SOLID CONCRETE OR GROUT-FILLED CMU MAY INCLUDE BUT DO NOT REQUIRE 1X WOOD BUCKS BETWEEN THE PRODUCT AND THE SUBSTRATE. INSTALLATIONS TO HOLLOW CMU REQUIRE THE USE OF 1X BUCKS BETWEEN THE PRODUCT AND SUBSTRATE.
7. A MINIMUM CENTER-TO-CENTER SPACING SHALL BE MAINTAINED BETWEEN ALL FASTENERS: 3" FOR MASONRY, 1" FOR WOOD AND METAL.
8. WOOD OR MASONRY OPENINGS, BUCKS AND BUCK FASTENERS SHALL BE PROPERLY DESIGNED BY THE ARCHITECT OR ENGINEER OF RECORD AND INSTALLED TO TRANSFER WIND LOADS TO THE STRUCTURE. SUBSTRATES SHALL MEET THE MINIMUM STRENGTH REQUIREMENTS AS SHOWN IN TABLE1, SHEET 6. CONCRETE AND MASONRY SUBSTRATES MAY NOT BE CRACKED.
9. SEALING AND FLASHING STRATEGIES FOR OVERALL WATER RESISTANCE OF INSTALLATION SHALL BE DONE BY OTHERS FOLLOWING THE CURRENT VERSION OF THE REFERENCE DOCUMENTS: FMA/AAMA 100(FIN WINDOWS), FMA/AAMA 200(FLANGE WINDOWS), FMA/WDMA 250(BOX WINDOWS), FMA/AAMA/WDMA 300(EXTERIOR DOORS)

NO.:	DESCRIPTION:	BY:	DATE:



LT
9/29/2016

LUCAS A. TURNER, P.E.
TX PE # 115094
1239 JABARA AVE.
NORTH PORT, FL 34288
PH. 941-380-1574

SHEET DESCRIPTION:
ANCHOR SCHEDULE AND NOTES

DRAWN BY: EMK	DATE: 11/12/15
DWG #: TDI-812	REV.: -
SCALE: 1:15	SHEET 5 OF 6

**8100 PVC
SINGLE HUNG
IMPACT**

NO.	DESCRIPTION:	BY:	DATE:



LT
9/29/2016

LUCAS A. TURNER, P.E.
TX PE # 115094
1239 JABARA AVE.
NORTH PORT, FL 34288
PH. 941-380-1574

SHEET DESCRIPTION:

INSTALLATION DETAILS

DRAWN BY: EMK	DATE: 11/12/15
DWG #: TDI-812	REV.: -
SCALE: 1:2	SHEET 6 OF 6

TYPICAL HEAD ANCHORAGE

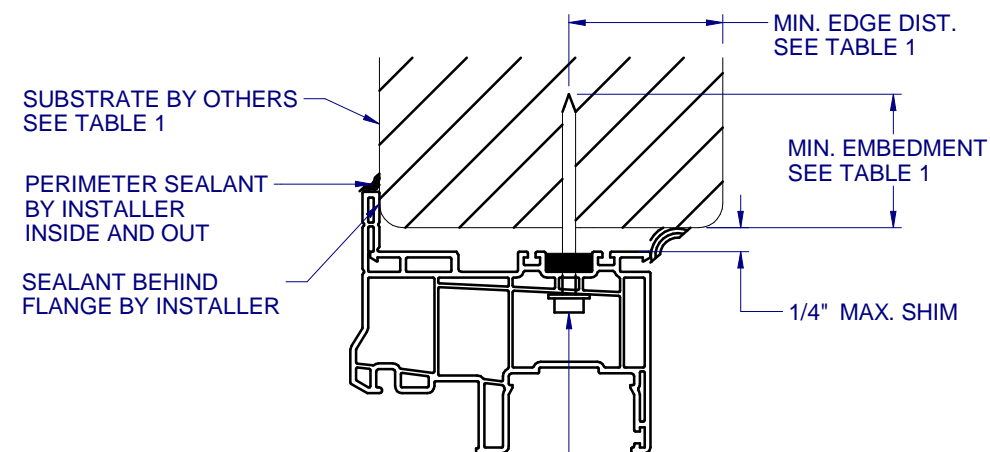

INSTALLATION ANCHOR SEE TABLE 1

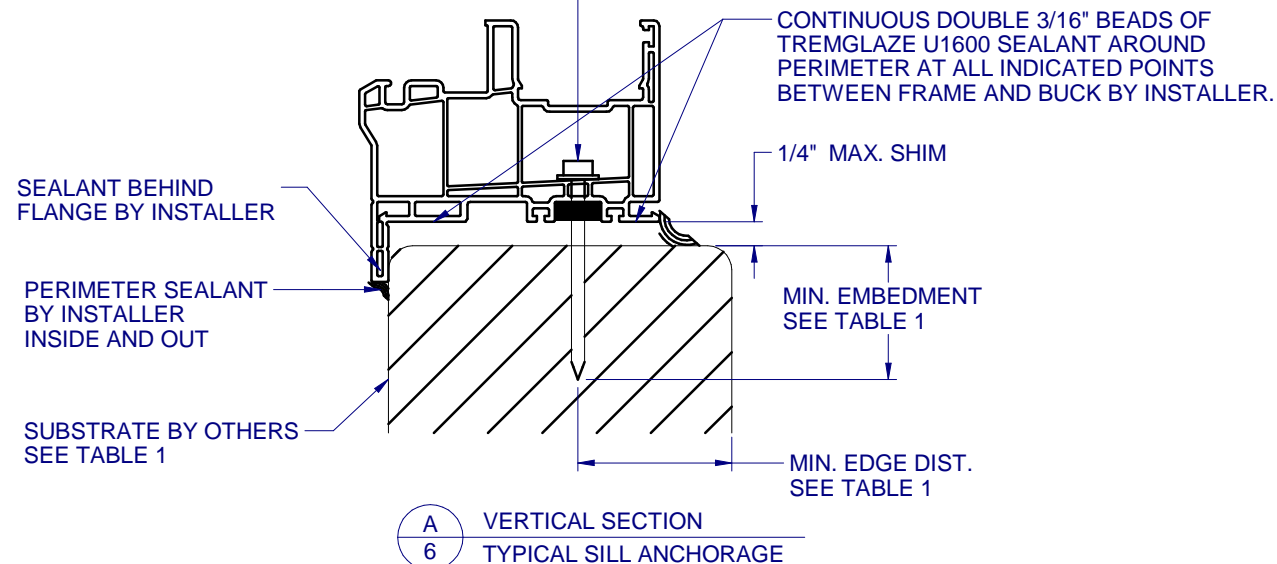

MIN. EMBEDMENT SEE TABLE 1
1/4" MAX. SHIM
SUBSTRATE BY OTHERS SEE TABLE 1

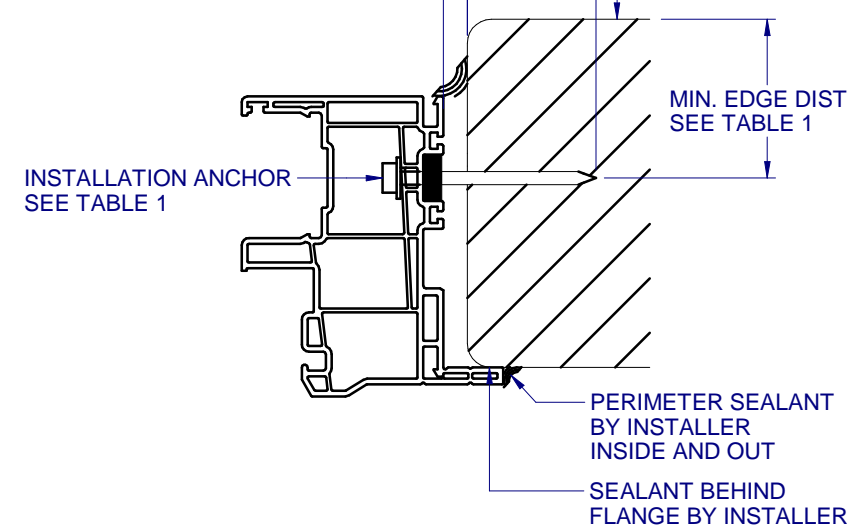

B
6 HORIZONTAL SECTION
TYPICAL JAMB ANCHORAGE

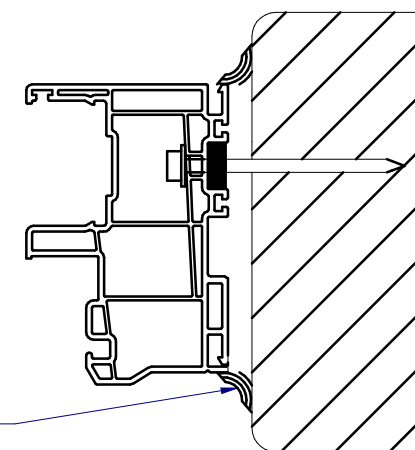

C
6 HORIZONTAL SECTION
BOX FRAME INSTALLATION
HEAD AND SILL SIMILAR FOR BOX INSTALLATION

FLANGE REMOVAL NOTE: PARTIALLY OR FULLY REMOVING THE FLANGE, UP TO AND INCLUDING A BOX-FRAME APPLICATION IS ACCEPTABLE PROVIDED:

- MIN. 1/4" FILLET OF CONSTRUCTION-GRADE ADHESIVE CAULK IS APPLIED INSIDE AND OUT, FULL PERIMETER, BY INSTALLER.
- PRODUCT ANCHORAGE IS IN ACCORDANCE WITH REQUIREMENTS AS SHOWN FOR FLANGE WINDOWS.

TABLE 1: APPROVED INSTALLATION FASTENERS

SUBSTRATE TYPE	ANCHOR TYPE	MIN. EMBEDMENT	MIN. EDGE DIST.
CONCRETE (2.0 KSI MIN.)	3/16" ITW TAPCON	1-1/2"	1-1/8"
HOLLOW OR GROUT-FILLED CMU (117 PCF MIN.)	3/16" ITW TAPCON	1"	2"
CONCRETE (2.85 KSI MIN.)	3/16" ELCO ULTRACON	1"	1"
GROUT-FILLED CMU (ASTM C-90)	3/16" ELCO ULTRACON	1-1/4"	2-1/2"
2X MIN. SOUTHERN PINE (G=0.55)	3/16" ITW TAPCON OR ELCO ULTRACON	1-3/8"	7/8"
2X MIN. SOUTHERN PINE (G=0.55)	#10 WOOD SCREW	1-3/8"	7/8"
16 GAUGE (0.060") MIN. STEEL STUD (33 KSI YIELD MIN)	#10-16 HILTI KWIK-FLEX OR ITW TEKS SELF-DRILLING SCREW	FULL THREAD THRU 0.060"	7/16"
1/8" ALUM. (6063-T5 MIN.) OR 1/8" STEEL (33 KSI MIN.)	#10 GRADE 5 SELF-TAPPING / DRILLING SCREW	FULL THREAD THRU 0.125"	7/16"