

ANDERSEN CORPORATION

A-SERIES PICTURE & FIXED TRANSOM WINDOWS (IMPACT)

INSTALLATION NOTES:

- ONE (1) INSTALLATION ANCHOR IS REQUIRED AT EACH ANCHOR LOCATION SHOWN.
- THE NUMBER OF INSTALLATION ANCHORS DEPICTED IS THE MINIMUM NUMBER OF ANCHORS TO BE USED FOR PRODUCT INSTALLATION OF THE MAXIMUM SIZE LISTED.
- INSTALL INDIVIDUAL INSTALLATION ANCHORS WITHIN A TOLERANCE OF ±1/2 INCH THE DEPICTED LOCATION & SPACING IN THE ANCHOR LAYOUT DETAILS (I.E., WITHOUT CONSIDERATION OF TOLERANCES). TOLERANCES ARE NOT CUMULATIVE FROM ONE INSTALLATION ANCHOR TO THE NEXT.
- SHIM AS REQUIRED AT EACH INSTALLATION ANCHOR WITH LOAD BEARING SHIM(S). MAXIMUM ALLOWABLE SHIM STACK TO BE 3/8 INCH. SHIM WHERE SPACE OF 1/16 INCH OR GREATER OCCURS. SHIM(S) SHALL BE CONSTRUCTED OF HIGH DENSITY PLASTIC OR BETTER.
- INSTALLATION CLIP:** FOR INSTALLATION INTO WOOD FRAMING USE TWO (2) #8 WOOD SCREWS PER LOCATION OF SUFFICIENT LENGTH TO ACHIEVE 1-1/2 INCH MINIMUM EMBEDMENT INTO WOOD SUBSTRATE.
- INSTALLATION CLIP:** FOR INSTALLATION INTO METAL STUD OR APPROVED MULLION USE TWO (2) #8-16 GR. 5 SELF-TAPPING SCREW PER LOCATION OF SUFFICIENT LENGTH TO ACHIEVE A MINIMUM OF 3 THREADS PENETRATION BEYOND METAL FRAME SUBSTRATE.
- INSTALLATION CLIP:** FOR INSTALLATION THROUGH 1X BUCK TO CONCRETE/MASONRY, OR DIRECTLY INTO CONCRETE/MASONRY, USE TWO (2) 3/16 INCH DIAMETER ITW TAPCONS PER LOCATION OF SUFFICIENT LENGTH TO ACHIEVE 1-1/4 INCH MINIMUM EMBEDMENT. ANCHORS SHALL BE INSTALLED THROUGH CLIP SUCH THAT A MINIMUM 1-1/8" C.C. SPACING IS MAINTAINED.
- MINIMUM EMBEDMENT AND EDGE DISTANCE EXCLUDE WALL FINISHES, INCLUDING BUT NOT LIMITED TO STUCCO, FOAM, BRICK VENEER, AND SIDING.
- INSTALLATION ANCHORS AND ASSOCIATED HARDWARE MUST BE MADE OF CORROSION RESISTANT MATERIAL OR HAVE A CORROSION RESISTANT COATING.
- FOR HOLLOW BLOCK AND GROUT FILLED BLOCK, DO NOT INSTALL INSTALLATION ANCHORS INTO MORTAR JOINTS. EDGE DISTANCE IS MEASURED FROM FREE EDGE OF BLOCK OR EDGE OF MORTAR JOINT INTO FACE SHELL OF BLOCK.
- INSTALLATION ANCHORS SHALL BE INSTALLED IN ACCORDANCE WITH ANCHOR MANUFACTURER'S INSTALLATION INSTRUCTIONS, AND ANCHORS SHALL NOT BE USED IN SUBSTRATES WITH STRENGTHS LESS THAN THE MINIMUM STRENGTH SPECIFIED BY THE ANCHOR MANUFACTURER.
- INSTALLATION ANCHOR CAPACITIES FOR PRODUCTS HEREIN ARE BASED ON SUBSTRATE MATERIALS WITH THE FOLLOWING PROPERTIES:
 - WOOD - MINIMUM SPECIFIC GRAVITY OF 0.55.
 - CONCRETE - MINIMUM COMPRESSIVE STRENGTH OF 3000 PSI.
 - GROUT-FILLED CMU- UNIT STRENGTH CONFORMS TO ASTM C-90 WITH MINIMUM COMPRESSIVE STRENGTH OF 2000 PSI AND GROUT CONFORMS TO ASTM C 476, MINIMUM GROUT COMPRESSIVE STRENGTH OF 2000 PSI.
 - HOLLOW BLOCK CMU - UNIT STRENGTH CONFORMS TO ASTM C-90 WITH MINIMUM COMPRESSIVE STRENGTH OF 2000 PSI.
 - STEEL - MINIMUM YIELD STRENGTH OF 33 KSI. MINIMUM WALL THICKNESS OF 35.9 MIL (0.0359" or 20 GAUGE). MIN. 1/2" EDGE DISTANCE.
 - ALUMINUM - MINIMUM ALLOY 6063-T5. MINIMUM WALL THICKNESS OF 0.078". MIN. 1/2" EDGE DISTANCE.

GENERAL NOTES:

- THE PRODUCT SHOWN HEREIN IS DESIGNED AND MANUFACTURED TO COMPLY WITH THE 2018 INTERNATIONAL BUILDING CODE (IBC) AND 2018 INTERNATIONAL RESIDENTIAL CODE (IRC) AND HAS BEEN EVALUATED ACCORDING TO THE FOLLOWING:
 - AAMA/WDMA/CSA 101/I.S.2/A440-17
 - ASTM E1886-13a
 - ASTM E1996-14a
- ADEQUACY OF THE EXISTING STRUCTURAL CONCRETE/MASONRY, 2X FRAMING, AND METAL FRAMING AS A MAIN WIND FORCE RESISTING SYSTEM CAPABLE OF WITHSTANDING AND TRANSFERRING APPLIED PRODUCT LOADS TO THE FOUNDATION IS THE RESPONSIBILITY OF THE ENGINEER OR ARCHITECT OF RECORD FOR THE PROJECT OF INSTALLATION.
- 1X AND 2X BUCKS (WHEN USED) SHALL BE DESIGNED AND ANCHORED TO PROPERLY TRANSFER ALL LOADS TO THE STRUCTURE. BUCK DESIGN AND INSTALLATION IS THE RESPONSIBILITY OF THE ENGINEER OR ARCHITECT OF RECORD FOR THE PROJECT OF INSTALLATION.
- THE INSTALLATION DETAILS DESCRIBED HEREIN ARE GENERIC AND MAY NOT REFLECT ACTUAL CONDITIONS FOR A SPECIFIC SITE. IF SITE CONDITIONS CAUSE INSTALLATION TO DEVIATE FROM THE REQUIREMENTS DETAILED HEREIN, A LICENSED ENGINEER OR ARCHITECT SHALL PREPARE SITE SPECIFIC DOCUMENTS.
- APPROVED IMPACT PROTECTIVE SYSTEM **IS NOT REQUIRED** ON THIS PRODUCT IN AREAS REQUIRING IMPACT RESISTANCE.
- WINDOW FRAME MATERIAL: PONDEROSA PINE (MIN. S.G. = 0.40)
- CLADDING MATERIAL: FIBERGLASS
- IN ACCORDANCE WITH THE FBC, WOOD COMPONENTS SHALL HAVE BEEN PRESERVATIVE TREATED OR SHALL BE OF A DURABLE SPECIES.
- GLASS MEETS THE REQUIREMENTS OF ASTM E 1300 GLASS CHARTS. SEE SHEET 4 FOR GLAZING DETAILS.

TABLE OF CONTENTS	
SHEET	SHEET DESCRIPTION
1	INSTALLATION & GENERAL NOTES
2	ELEVATION, ANCHOR LAYOUTS, & ASSEMBLY NOTES
3	VERTICAL SECTIONS
4	HORIZONTAL SECTIONS & GLAZING OPTIONS
5	BILL OF MATERIALS & COMPONENTS

OVERALL SIZE		DESIGN PRESSURE	MIN. GLAZING OPTION	MISSILE IMPACT RATING
WIDTH	HEIGHT			
55 1/4"	55 1/4"	+70/- 70 PSF	OPTION 1 OR 2	LARGE & SMALL MISSILE IMPACT
71 1/4"	79 1/4"	+70/- 70 PSF	OPTION 3 OR 4	LARGE & SMALL MISSILE IMPACT
71 1/4"	95 1/4"	+65/- 65 PSF	OPTION 3	LARGE & SMALL MISSILE IMPACT
95 1/4"	71 1/4"	+65/- 65 PSF	OPTION 3	LARGE & SMALL MISSILE IMPACT



100 FOURTH AVE NORTH
BAYPORT, MN 55003-1096

PH: (651) 264-5150 FX: (651) 264-5485

TITLE: A-SERIES FIXED WINDOW
(IMPACT)

INSTALLATION &
GENERAL NOTES

PREPARED BY:
BUILDING DROPS, INC.
398 E. DANIA BEACH BLVD., STE. 338
DANIA BEACH, FL 33004
PH: (954) 399-8478
FAX: (954) 744-4738
WEB: www.buildingdrops.com



REMARKS	BY	DATE

THE INSTALLATION DETAILS DESCRIBED HEREIN ARE GENERIC AND MAY NOT REFLECT ACTUAL CONDITIONS FOR A SPECIFIC SITE. IF SITE CONDITIONS CAUSE INSTALLATION TO DEVIATE FROM THE REQUIREMENTS DETAILED HEREIN, A LICENSED ENGINEER OR ARCHITECT SHALL PREPARE SITE SPECIFIC DOCUMENTS FOR USE WITH THIS DOCUMENT.



HERMES F. NORERO, P.E.
TEXAS P.E. No. 118471
BUILDING DROPS, INC
398 E. DANIA BEACH BLVD. # 338
DANIA BEACH, FL 33004
TBPE FIRM No. 13734

DATE: 03.13.20

DWG. BY:
MS

CHK. BY:
HFN

SCALE: NTS

DWG. #: AWD272

SHEET:

1

OF 5



100 FOURTH AVE NORTH
BAYPORT, MN 55003-1096
PH: (651) 264-5150 FX: (651) 264-5485

TITLE: **A-SERIES FIXED WINDOW (IMPACT)**
ELEVATIONS, ANCHOR LAYOUTS, & ASSEMBLY NOTES
PREPARED BY: **BUILDING DROPS, INC.**
398 E. DANIA BEACH BLVD., STE. 338
DANIA BEACH, FL 33004
PH: (954) 399-8478
FAX: (954) 744-4738
WEB: www.buildingdrops.com

REMARKS	BY	DATE

THE INSTALLATION DETAILS DESCRIBED HEREIN ARE GENERIC AND MAY NOT REFLECT ACTUAL CONDITIONS FOR A SPECIFIC SITE. IF SITE CONDITIONS CAUSE INSTALLATION TO DEVIATE FROM THE REQUIREMENTS DETAILED HEREIN, A LICENSED ENGINEER OR ARCHITECT SHALL PREPARE SITE SPECIFIC DOCUMENTS FOR USE WITH THIS DOCUMENT.



HERMES F. NORERO, P.E.
TEXAS P.E. No 118471
BUILDING DROPS, INC
398 E. DANIA BEACH BLVD. # 338
DANIA BEACH, FL 33004
TBPE FIRM No. 13734

DATE: **03.13.20**

DWG. BY: **MS** CHK. BY: **HFN**

SCALE: **NTS**

DWG. #: **AWD272**

SHEET:

2

OF 5

ANCHOR LEGEND
— INSTALLATION CLIP LOCATION.

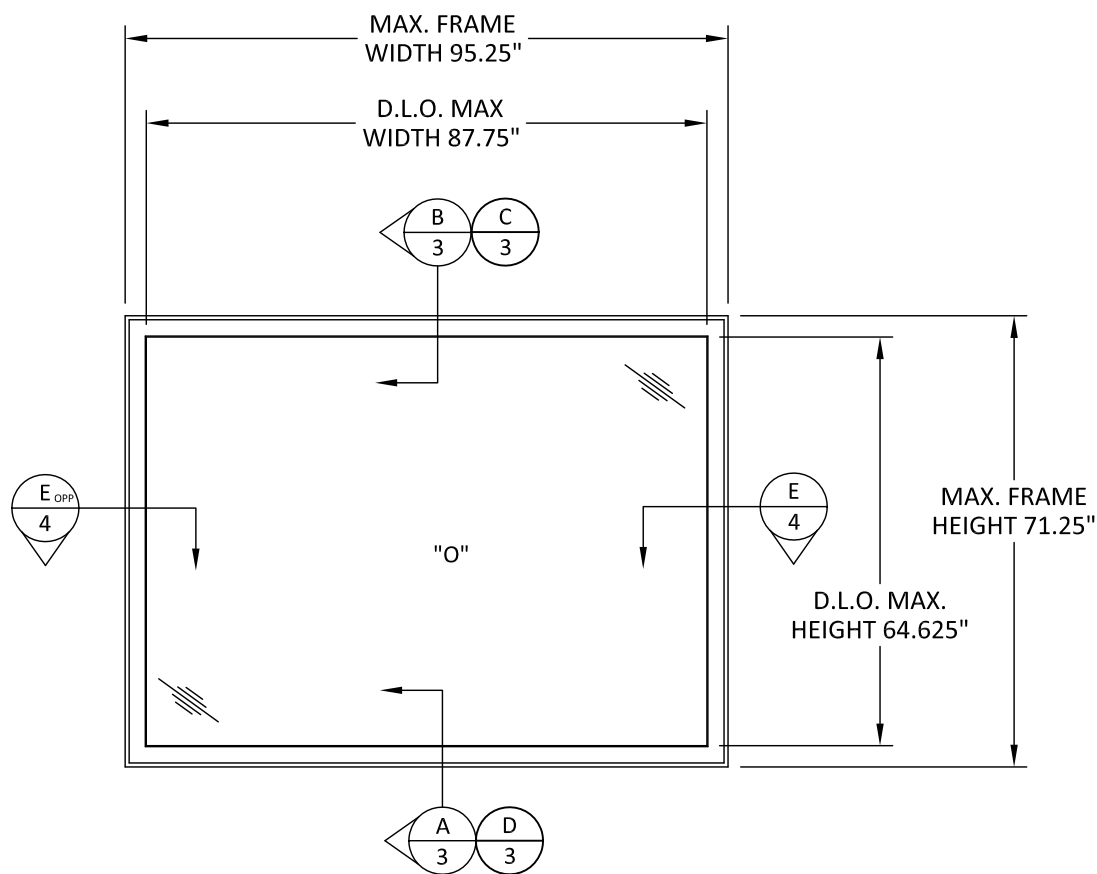

ELEVATION

ASSEMBLY NOTES:

- 1) INSIDE GLASS STOPS SHALL BE SECURED WITH 3/16" X 1-1/4" STAPLES 3-1/2" FROM END OF PART AND 6" O.C. THEREAFTER.
- 2) FRAME MEMBERS SNAP-FITS INTO FRAME CLADDING AND IS FASTENED WITH 7/16" X 1" STAPLES 3" FROM CORNERS AND 10" O.C. THEREAFTER.
- 3) TRIM STOPS SHALL BE SECURED WITH VINYL SPLINE.
- 4) INSIDE STOPS SHALL BE SECURED WITH 7/16" X 1-1/2" STAPLES 1-1/2" FROM END OF PART AND 8" O.C. THEREAFTER.

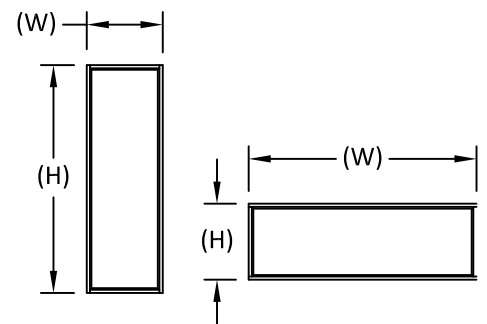

NOTE:
WINDOW WIDTH (W) AND HEIGHT (H) ARE INTERCHANGEABLE FOR ALL SIZES SHOWN HEREIN NOT TO EXCEED MAXIMUM TESTED SQUARE FOOT AREA. ANCHOR SPACING SHALL NOT EXCEED THOSE SHOWN FOR LONG OR SHORT LEG OF UNIT.

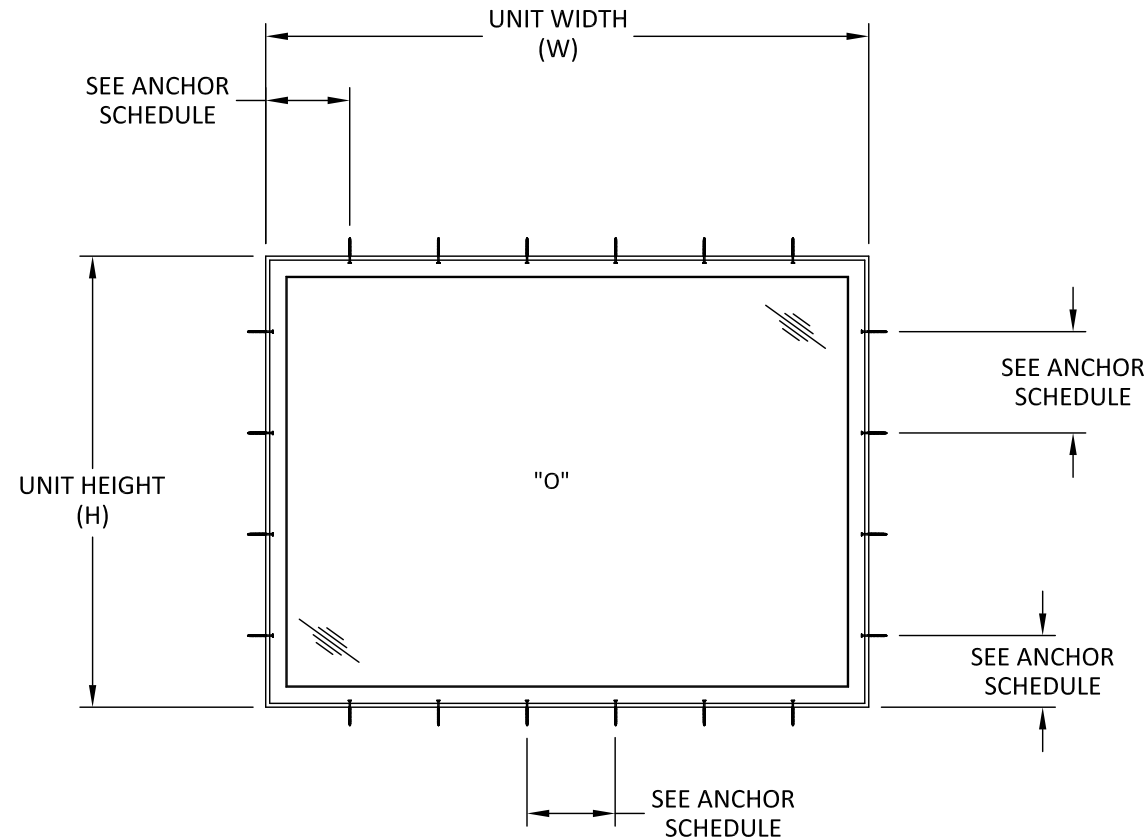

TYPICAL ANCHOR LAYOUT

INSTALLATION CLIP

ANCHOR SCHEDULE – HEAD/JAMBS/SILL	
LEG LENGTH (L)	QUANTITY OF CLIPS
$L > 79.25"$	9
$71.25" < L \leq 79.25"$	7
$63.25" < L \leq 71.25"$	6
$51.25" < L \leq 63.25"$	4
$35.25" < L \leq 51.25"$	3
$L \leq 35.25"$	2

ANCHOR SCHEDULE NOTES:

- 1) INSTALLATION CLIPS SHALL BE LOCATED 12" FROM CORNERS AND EQUALLY SPACED THEREAFTER.
- 2) IF ONE INSTALLATION CLIP IS SPECIFIED, THE CLIP SHALL BE LOCATED AT MIDSPAN OF FRAME MEMBER.



100 FOURTH AVE NORTH
BAYPORT, MN 55003-1096

PH: (651) 264-5150 FX: (651) 264-5485

TITLE: A-SERIES FIXED WINDOW
(IMPACT)
VERTICAL SECTIONS

PREPARED BY:
BUILDING DROPS, INC.
398 E. DANIA BEACH BLVD., STE. 338
DANIA BEACH, FL 33004
PH: (954) 399-8478
FAX: (954) 744-4738
WEB: www.buildingdrops.com

REMARKS	BY	DATE

THE INSTALLATION DETAILS DESCRIBED HEREIN ARE GENERIC AND MAY NOT REFLECT ACTUAL CONDITIONS FOR A SPECIFIC SITE. IF SITE CONDITIONS CAUSE INSTALLATION TO DEVIATE FROM THE REQUIREMENTS DETAILED HEREIN, A LICENSED ENGINEER OR ARCHITECT SHALL PREPARE SITE SPECIFIC DOCUMENTS FOR USE WITH THIS DOCUMENT.



HERMES F. NORERO, P.E.
TEXAS P.E. No. 118471
BUILDING DROPS, INC
398 E. DANIA BEACH BLVD. # 338
DANIA BEACH, FL 33004
TBPE FIRM No. 13734

DATE: 03.13.20

DWG. BY: MS CHK. BY: HFN

SCALE: NTS

DWG. #: AWD272

SHEET:

3

OF 5

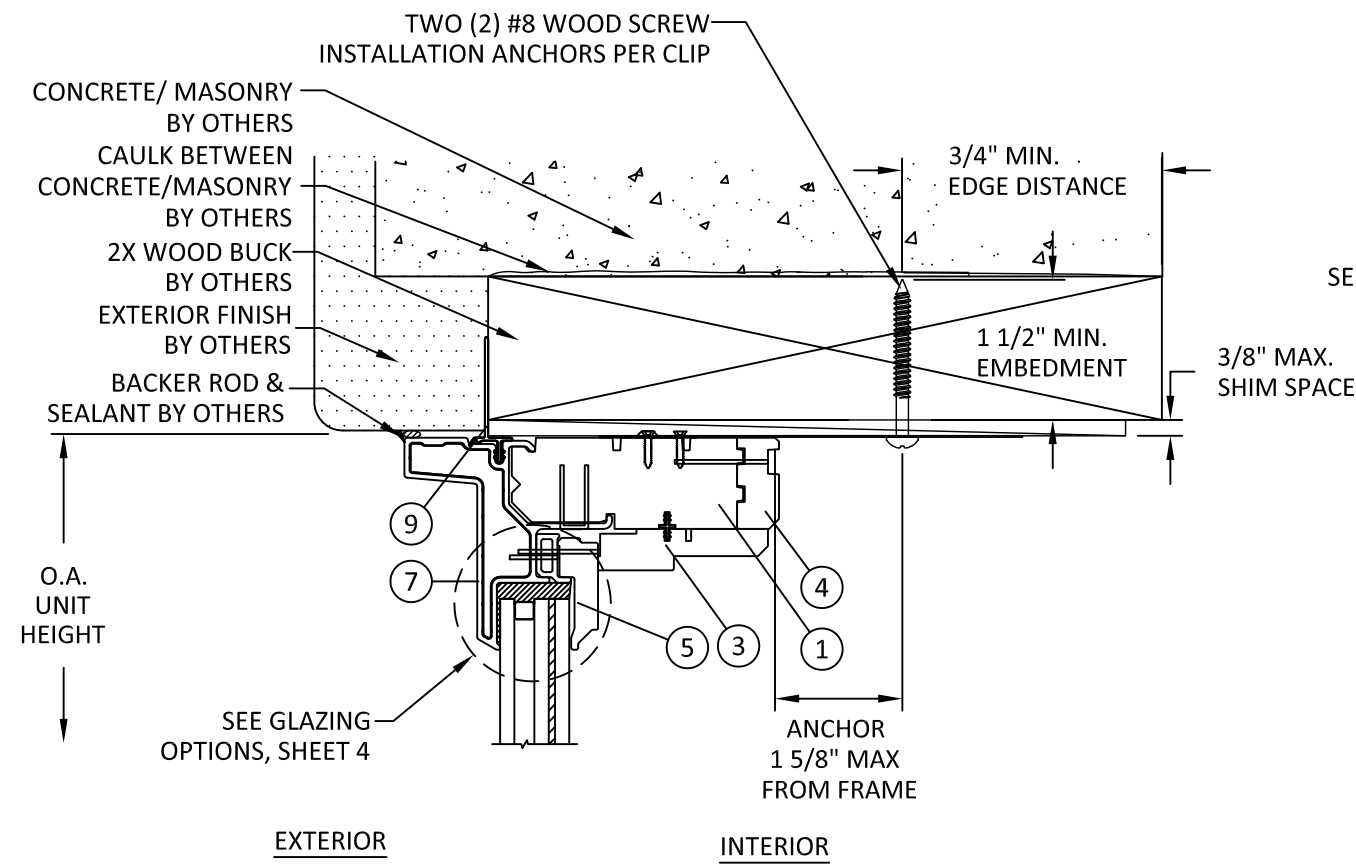

B
3
VERTICAL SECTION
HEAD - 2X WOOD BUCK
APW

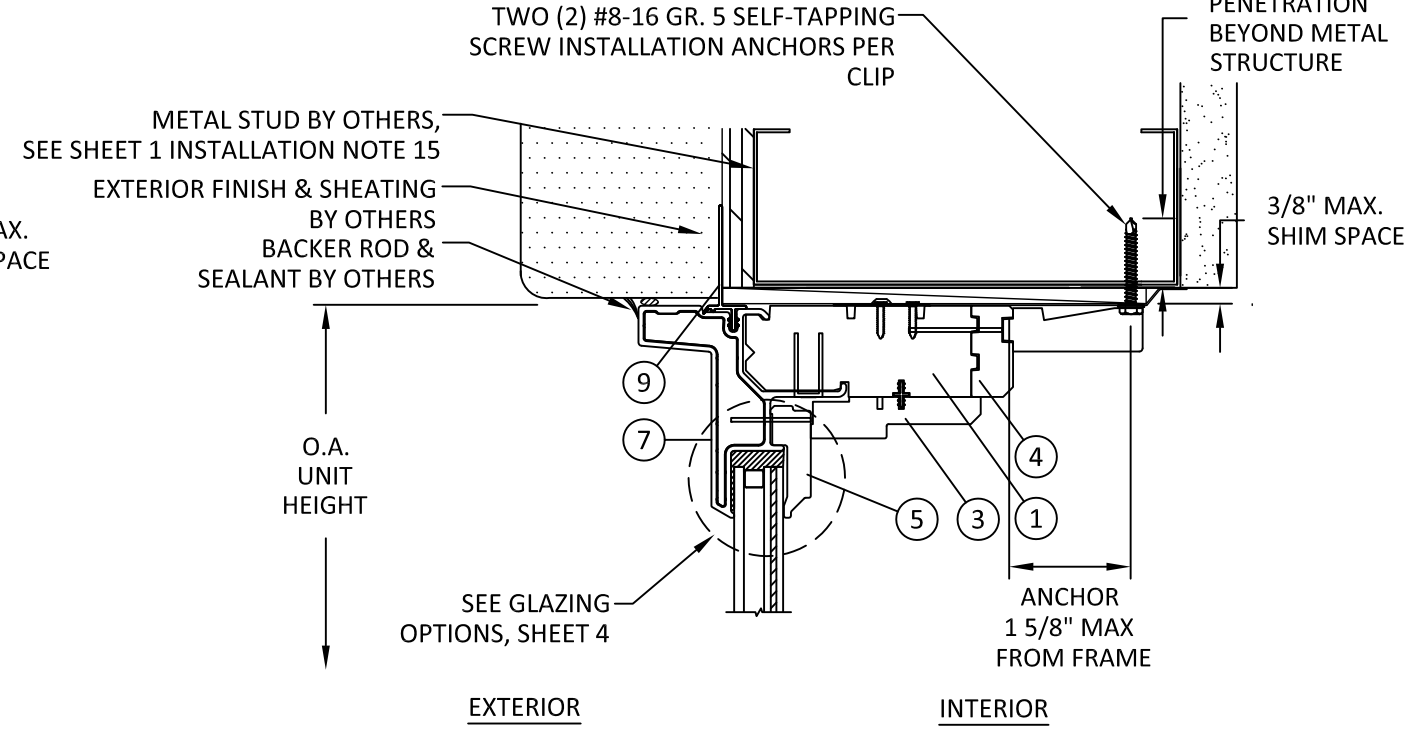

C
3
VERTICAL SECTION
HEAD-METAL STUD
ATF

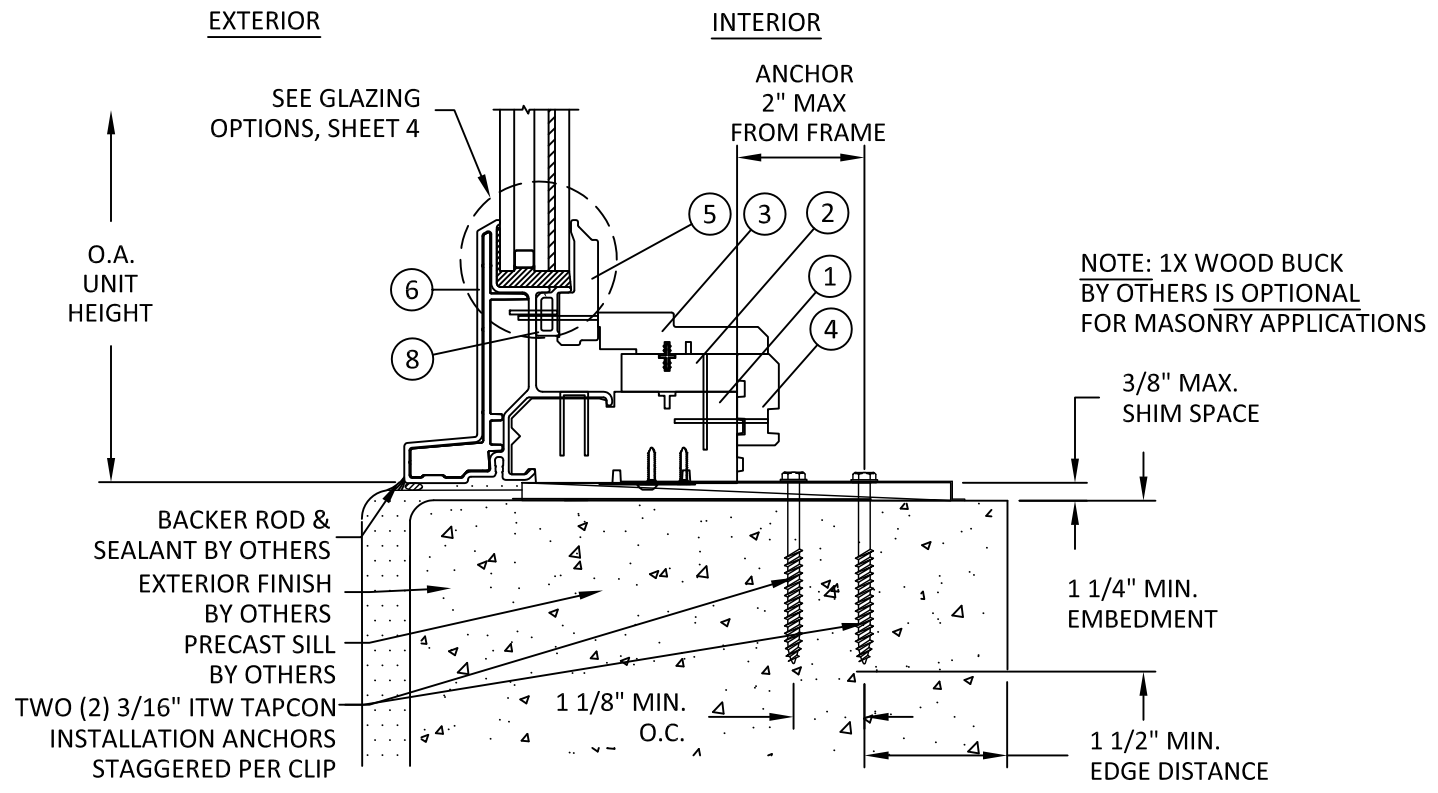

A
3
VERTICAL SECTION
SILL - CONCRETE/MASONRY
APW

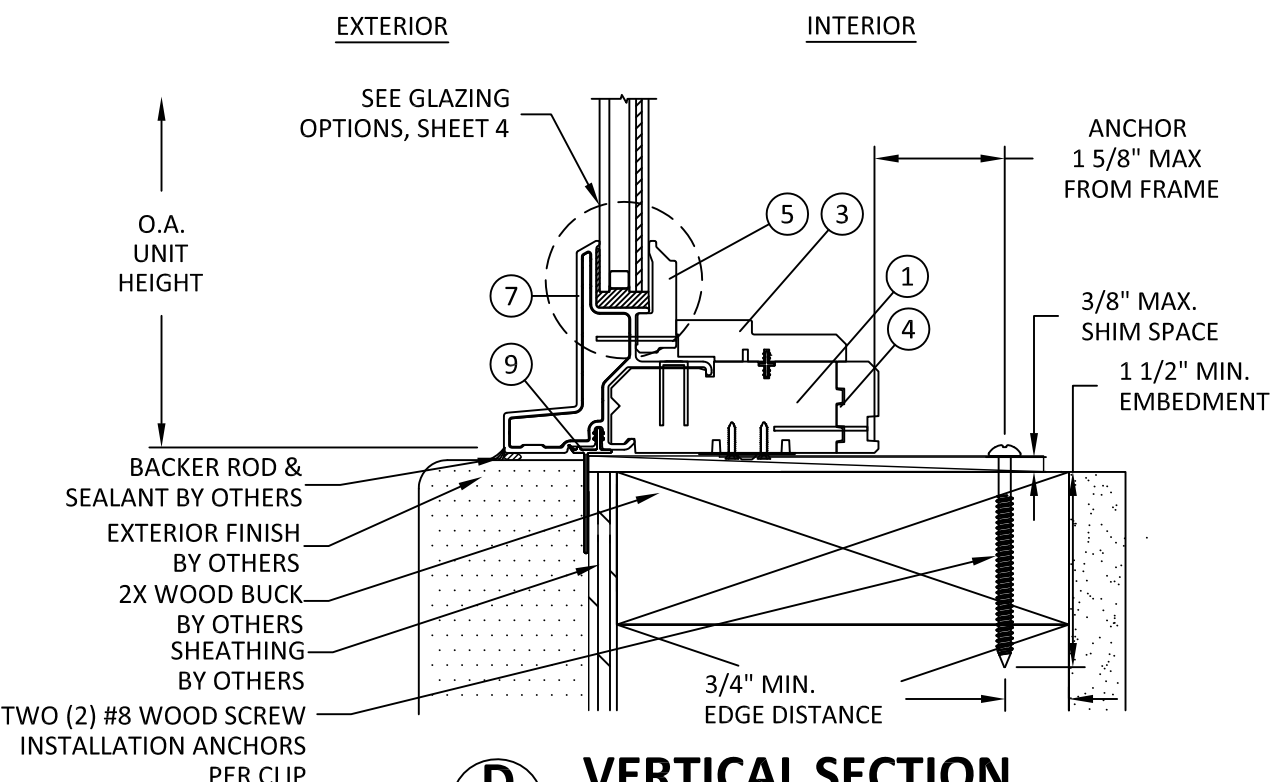

D
3
VERTICAL SECTION
SILL - 2X WOOD FRAME
ATF

4/20/2020 2:54 PM s:\projects\andersen_windows\tdr-20-0302-1_tdr_submittal_fig_reinforced_mullion_revision.dwg\awd272_a-series_fixed.dwg



100 FOURTH AVE NORTH
BAYPORT, MN 55003-1096

PH: (651) 264-5150 FX: (651) 264-5485

TITLE: **A-SERIES FIXED WINDOW (IMPACT)**
HORIZONTAL SECTIONS & GLAZING OPTIONS
PREPARED BY: **BUILDING DROPS, INC.**
398 E. DANIA BEACH BLVD., STE. 338
DANIA BEACH, FL 33004
PH: (954) 399-8478
FAX: (954) 744-4738
WEB: www.buildingdrops.com

REMARKS	BY	DATE

THE INSTALLATION DETAILS DESCRIBED HEREIN ARE GENERIC AND MAY NOT REFLECT ACTUAL CONDITIONS FOR A SPECIFIC SITE. IF SITE CONDITIONS CAUSE INSTALLATION TO DEVIATE FROM THE REQUIREMENTS DETAILED HEREIN, A LICENSED ENGINEER OR ARCHITECT SHALL PREPARE SITE SPECIFIC DOCUMENTS FOR USE WITH THIS DOCUMENT.



HERMES F. NORERO, P.E.
TEXAS P.E. No. 118471
BUILDING DROPS, INC
398 E. DANIA BEACH BLVD. # 338
DANIA BEACH, FL 33004
TBPE FIRM No. 13734

DATE:	03.13.20
DWG. BY:	MS
CHK. BY:	HFN
SCALE:	NTS
DWG. #:	AWD272
SHEET:	4

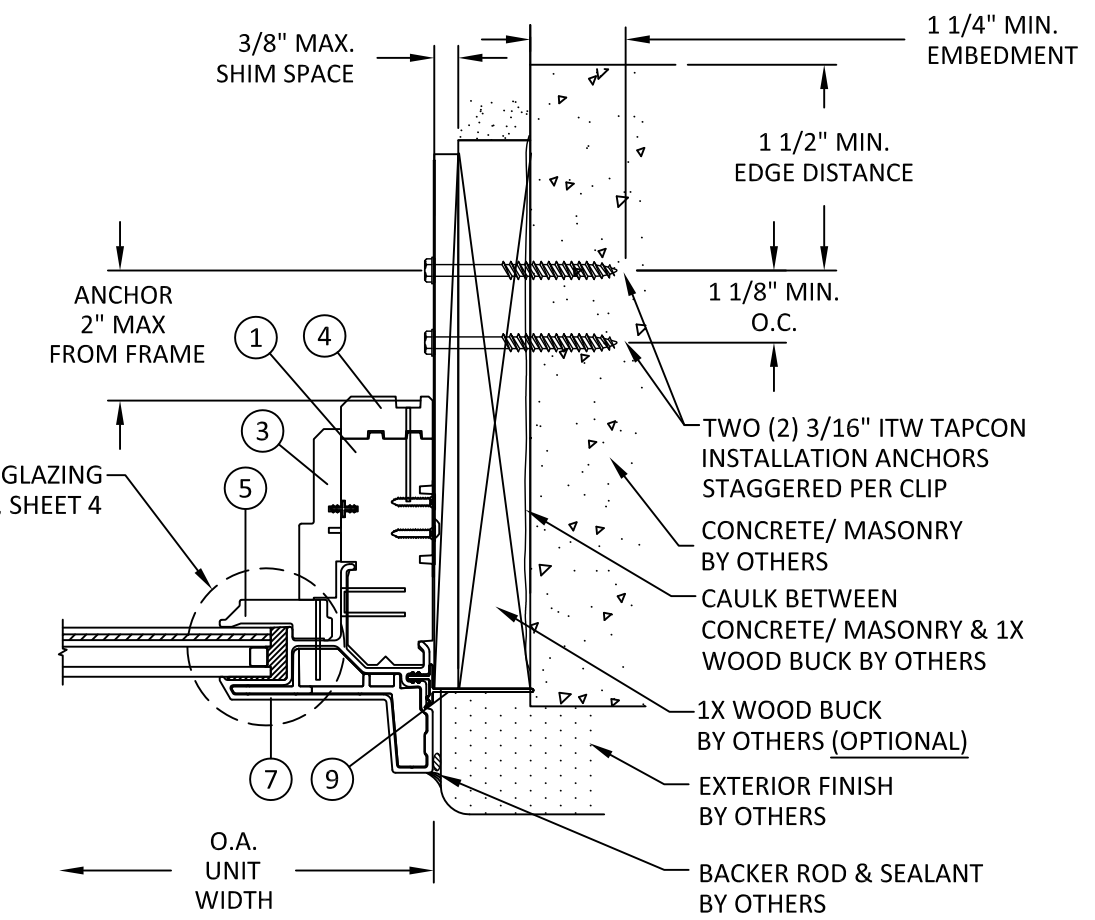

E 4
HORIZONTAL SECTION
JAMB - CONCRETE/MASONRY
APW

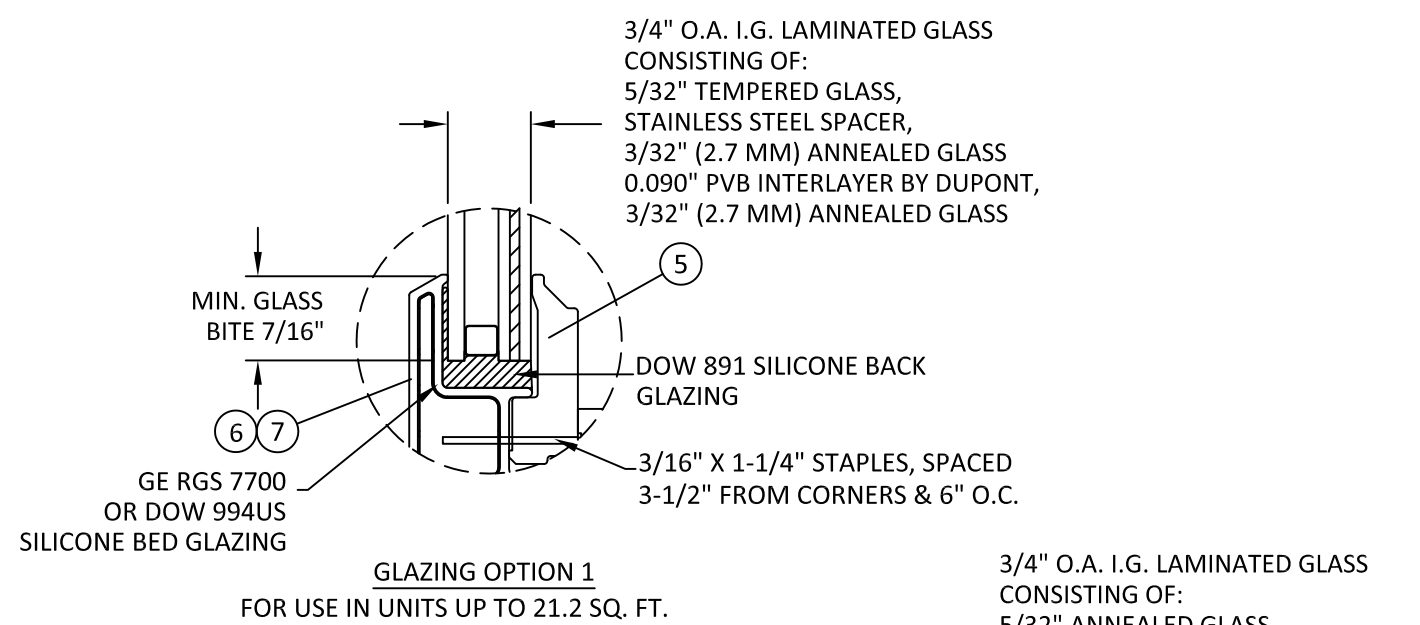

GLAZING OPTION 1
FOR USE IN UNITS UP TO 21.2 SQ. FT.

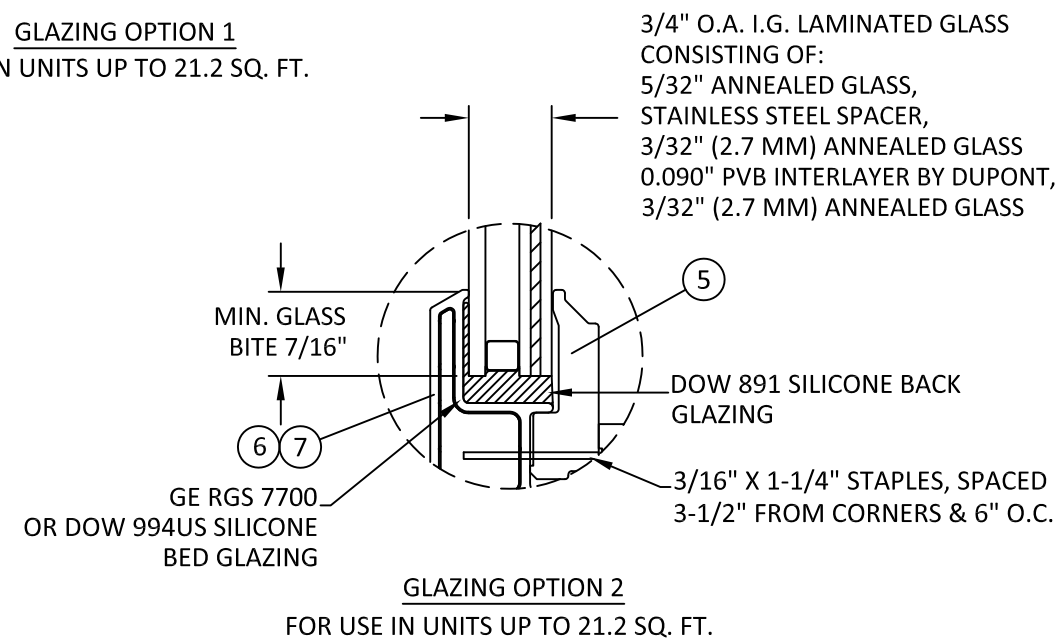

GLAZING OPTION 2
FOR USE IN UNITS UP TO 21.2 SQ. FT.

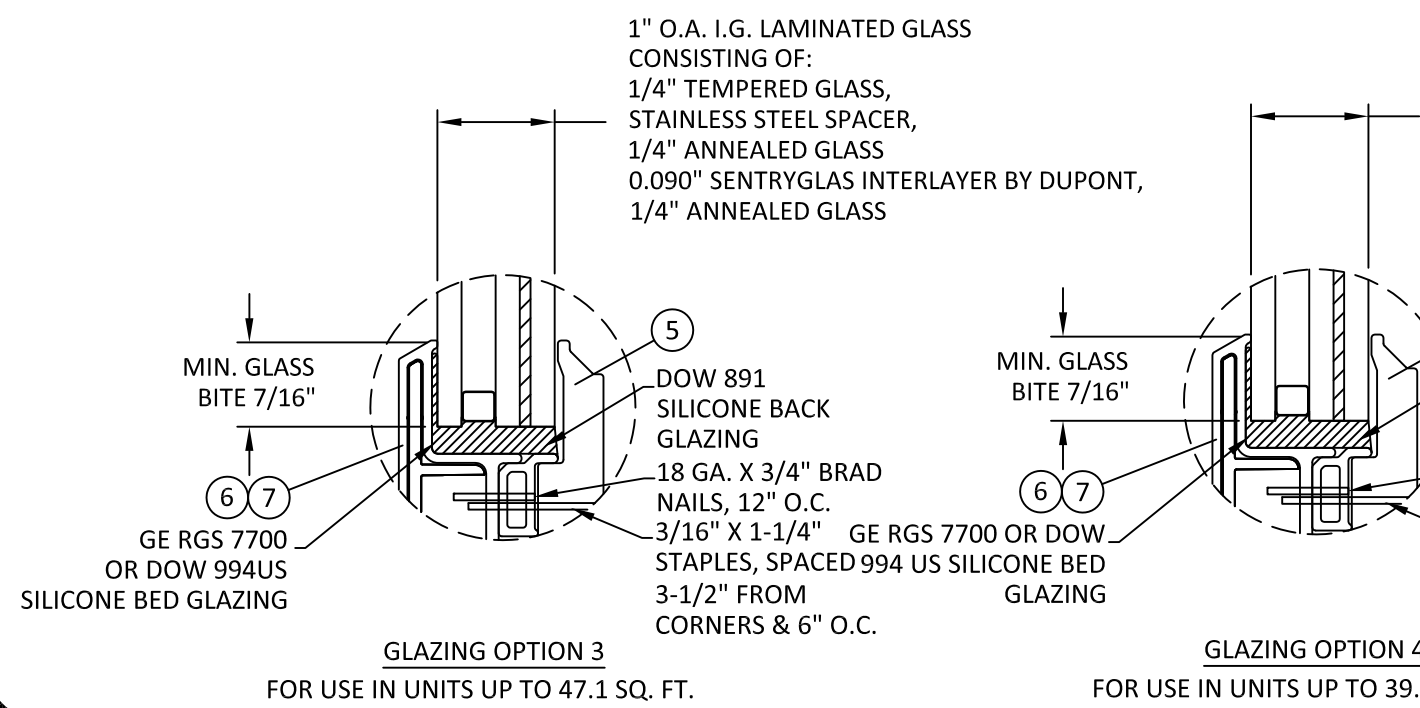

GLAZING OPTION 3
FOR USE IN UNITS UP TO 47.1 SQ. FT.

GLAZING OPTION 4
FOR USE IN UNITS UP TO 39.2 SQ. FT.

NOTE:
1) FIXED GLASS LITES GREATER THAN 36" IN WIDTH SHALL HAVE TWO APPROVED SETTING BLOCKS.
2) FOR INSTALLATION ABOVE 30 FT. ABOVE GRADE IN AREAS REQUIRING IMPACT RESISTANCE, ALL UNITS MUST BE SAFETY GLAZED OR COVERED BY AN IMPACT PROTECTIVE SYSTEM.

4/20/2020 2:54 PM

s:\projects\andersen\windows\tdi-20-0302-1 - tdi submittal - fig reinforced mullion revision.dwg\awd272 a-series fixed.dwg

BILL OF MATERIALS

ITEM #	DESCRIPTION	MATERIAL	MANUFACTURER
1	FRAME	WOOD	ANDERSEN
2	SILL FILLER BLOCK - APW	WOOD	ANDERSEN
3	TRIM STOP	WOOD	ANDERSEN
4	INSIDE TRIM STOP	WOOD	ANDERSEN
5	GLAZING STOP	WOOD	ANDERSEN
6	FRAME CLADDING - APW SILL	FIBERGLASS	ANDERSEN
7	FRAME CLADDING - APW/ATF	FIBERGLASS	ANDERSEN
8	GLASS SPACER - 1" GLAZING	RIGID PVC	ANDERSEN
9	NAILING FLANGE	RIGID PVC	ANDERSEN
10	INSTALLATION CLIP	304 SS	ANDERSEN

NOTE: ALL WOOD COMPONENTS ARE PONDEROSA PINE (MIN. S.G. = 0.40)



100 FOURTH AVE NORTH
BAYPORT, MN 55003-1096

PH: (651) 264-5150 FX: (651) 264-5485

TITLE: A-SERIES FIXED WINDOW (IMPACT)
BILL OF MATERIALS & COMPONENTS
PREPARED BY: BUILDING DROPS, INC.
398 E. DANIA BEACH BLVD., STE. 338
DANIA BEACH, FL 33004
PH: (954) 399-8478
FAX: (954) 744-4738
WEB: www.buildingdrops.com

REMARKS	BY	DATE

THE INSTALLATION DETAILS DESCRIBED HEREIN ARE GENERIC AND MAY NOT REFLECT ACTUAL CONDITIONS FOR A SPECIFIC SITE. IF SITE CONDITIONS CAUSE INSTALLATION TO DEVIATE FROM THE REQUIREMENTS DETAILED HEREIN, A LICENSED ENGINEER OR ARCHITECT SHALL PREPARE SITE SPECIFIC DOCUMENTS FOR USE WITH THIS DOCUMENT.



HERMES F. NORERO, P.E.
TEXAS P.E. No. 118471
BUILDING DROPS, INC
398 E. DANIA BEACH BLVD. # 338
DANIA BEACH, FL 33004
TBPE FIRM No. 13734

DATE: 03.13.20
DWG. BY: MS
CHK. BY: HFN
SCALE: NTS
DWG. #: AWD272
SHEET:

1 FRAME WOOD

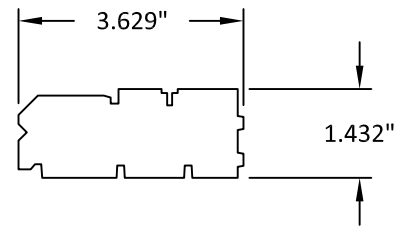

2 SILL FILLER BLOCK - APW WOOD

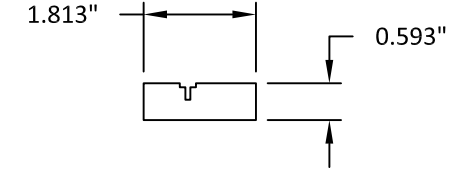

3 TRIM STOP WOOD

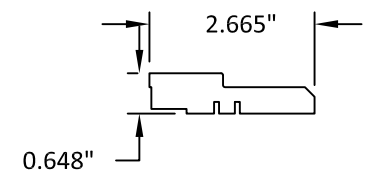

4 INSIDE TRIM STOP WOOD

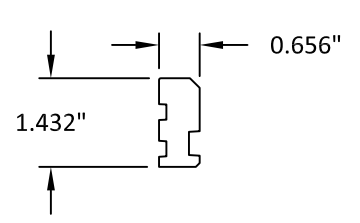

5 GLAZING STOP WOOD

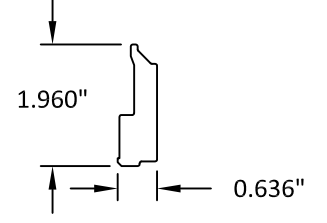

6 FRAME CLADDING - APW SILL FIBERGLASS

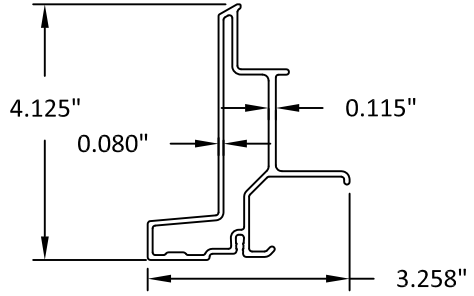

7 FRAME CLADDING - APW/ATF FIBERGLASS

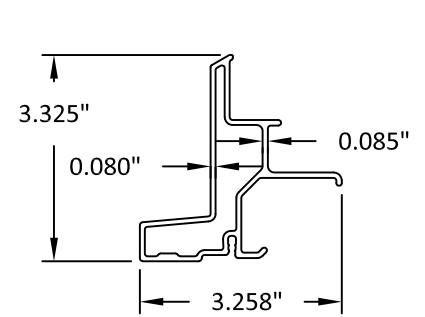

8 GLASS SPACER - 1\"/>

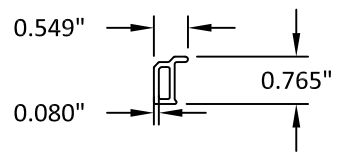

9 NAILING FLANGE RIGID PVC

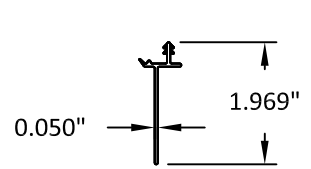

10 INSTALLATION CLIP 304 SS

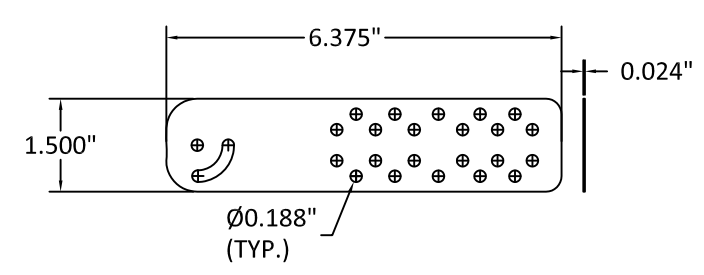

NOTE: INSTALLATION CLIPS SHALL BE ATTACHED TO WINDOW FRAME WITH TWO (2) #8 X 5/8\"/>

4/20/2020 2:54 PM
s:\projects\andersen windows\tdi-20-0302-1 - tdi submittal - fg reinforced mullion revision.dwg\awd272 a-series fixed.dwg