

REVISIONS			
REV	DESCRIPTION	DATE	APPROVED
B	REVISED PER NEW CODE	11/15/2021	R.L.

NOTES:

- 1) THE PRODUCT SHOWN HEREIN IS DESIGNED AND MANUFACTURED TO COMPLY WITH REQUIREMENTS OF THE 2018 IBC AND 2018 IRC.
- 2) WOOD FRAMING AND MASONRY OPENING TO BE DESIGNED AND ANCHORED TO PROPERLY TRANSFER ALL LOADS TO STRUCTURE. FRAMING AND MASONRY OPENING IS THE RESPONSIBILITY OF THE ARCHITECT OR ENGINEER OF RECORD.
- 3) 1X BUCK OVER MASONRY/CONCRETE IS OPTIONAL. WHERE 1X BUCK IS NOT USED DISSIMILAR MATERIALS MUST BE SEPARATED WITH APPROVED COATING OR MEMBRANE. SELECTION OF COATING OR MEMBRANE IS THE RESPONSIBILITY OF THE ARCHITECT OR ENGINEER OF RECORD.
- 4) ALLOWABLE STRESS INCREASE OF 1/3 WAS NOT USED IN THE DESIGN OF THE PRODUCT SHOWN HEREIN. WIND LOAD DURATION FACTOR Cd=1.6 WAS USED FOR WOOD ANCHOR CALCULATIONS.
- 5) FRAME MATERIAL: EXTRUDED RIGID PVC.
- 6) UNITS MUST BE GLAZED PER ASTM E1300, SEE SHEET 2 FOR GLASS DETAILS.
- 7) APPROVED IMPACT PROTECTIVE SYSTEM IS NOT REQUIRED FOR THIS PRODUCT IN WIND BORNE DEBRIS REGIONS.
- 8) SHIM AS REQUIRED AT EACH INSTALLATION ANCHOR WITH LOAD BEARING SHIM. SHIM WHERE SPACE OF 1/16" OR GREATER OCCURS. MAXIMUM ALLOWABLE SHIM STACK TO BE 1/4".
- 9) FOR ANCHORING INTO MASONRY/CONCRETE USE 3/16" TAPCONS WITH SUFFICIENT LENGTH TO ACHIEVE A 1 1/4" MINIMUM EMBEDMENT INTO SUBSTRATE WITH 2" MINIMUM EDGE DISTANCE. LOCATE ANCHORS AS SHOWN IN ELEVATIONS AND INSTALLATION DETAILS.
- 10) FOR ANCHORING INTO WOOD FRAMING OR 2X BUCK USE #10 WOOD SCREWS WITH SUFFICIENT LENGTH TO ACHIEVE A 1 1/4" MINIMUM EMBEDMENT INTO SUBSTRATE. LOCATE ANCHORS AS SHOWN IN ELEVATIONS AND INSTALLATION DETAILS.
- 11) FOR ANCHORING INTO METAL STRUCTURE USE #10 SMS OR SELF DRILLING SCREWS SCREWS WITH SUFFICIENT LENGTH TO ACHIEVE 3 THREADS MINIMUM BEYOND STRUCTURE INTERIOR WALL. LOCATE ANCHORS AS SHOWN IN ELEVATIONS AND INSTALLATION DETAILS.
- 12) ALL FASTENERS TO BE CORROSION RESISTANT.
- 13) INSTALLATION ANCHORS SHALL BE INSTALLED IN ACCORDANCE WITH ANCHOR MANUFACTURER'S INSTALLATION INSTRUCTIONS, AND ANCHORS SHALL NOT BE USED IN SUBSTRATES WITH STRENGTHS LESS THAN THE MINIMUM STRENGTH SPECIFIED BELOW:
 - A. WOOD – MINIMUM SPECIFIC GRAVITY OF G=0.42
 - B. CONCRETE – MINIMUM COMPRESSIVE STRENGTH OF 3,192 PSI.
 - C. MASONRY – STRENGTH CONFORMANCE TO ASTM C-90, GRADE N, TYPE 1 (OR GREATER).
 - D. METAL STRUCTURE: STEEL 18GA, 33KSI OR ALUMINUM 6063-T5 1/8" THICK MINIMUM

SIGNED: 12/02/2021

TABLE OF CONTENTS	
SHEET NO.	DESCRIPTION
1	NOTES
2	ELEVATION AND GLAZING DETAIL
3 - 4	INSTALLATION DETAILS

REGENCY PLUS, INC. 2000 LOCUST GAP HIGHWAY MT. CARMEL, PA 17851		
SERIES 6212 VINYL CASEMENT WINDOW 36" X 68" – IMPACT NOTES		
DRAWN: A.P.	DWG NO. 08-01713	REV B
SCALE NTS	DATE 08/29/12	SHEET 1 OF 4
L. ROBERTO LOMAS P.E. 1432 WOODFORD RD LEWISVILLE, NC 27023 434-688-0609 rllomas@rlomaspe.com		

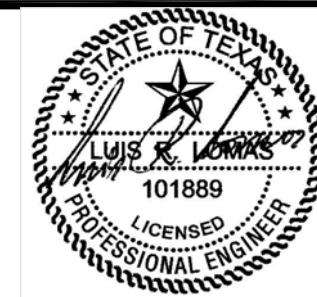

Luis R. Lomas P.E.
TX No.: 101889

REVISIONS			
REV	DESCRIPTION	DATE	APPROVED
B	REVISED PER NEW CODE	11/15/2021	R.L.

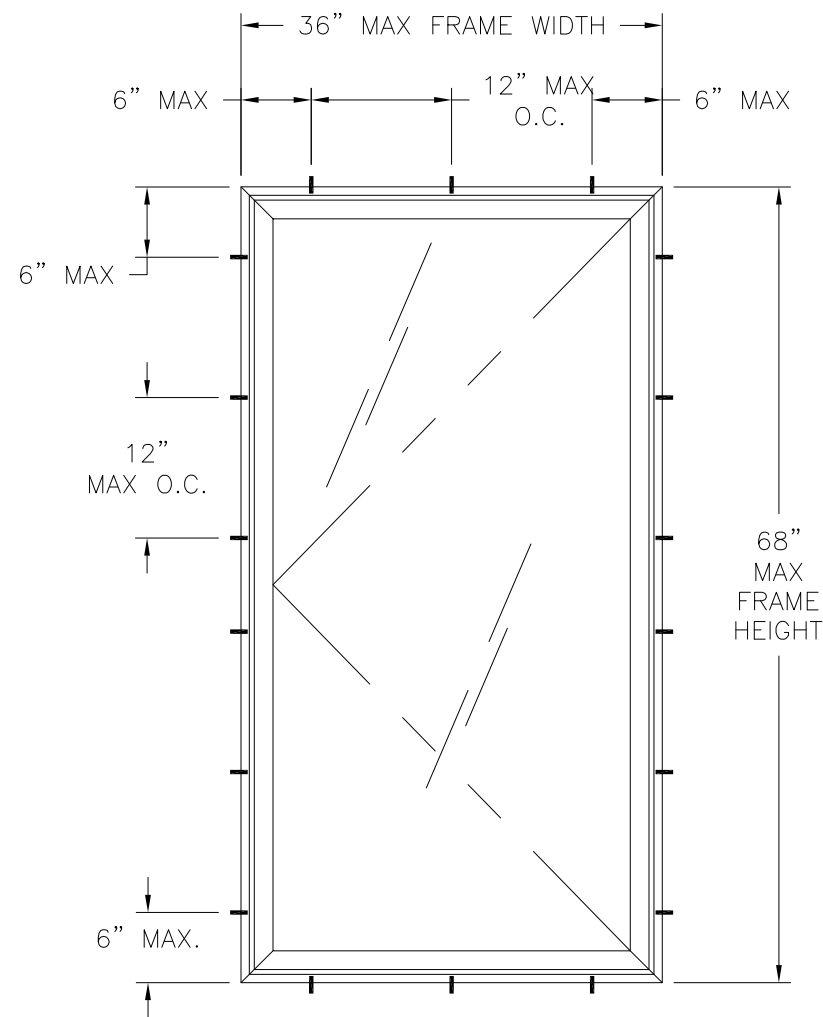

6212 CASEMENT
EXTERIOR VIEW

- NOTES:**
1. MAXIMUM PANEL SIZE: 34 1/4" X 66 1/4"
 2. MAXIMUM D.L.O.: 29 1/8" X 61 1/8"

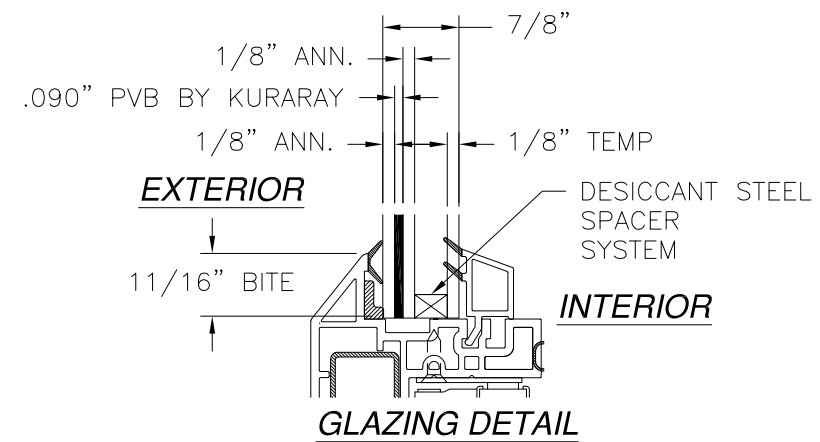

DESIGN PRESSURE RATING	IMPACT RATING
±50.0PSF	LARGE MISSILE IMPACT

MISSILE LEVEL D, WIND ZONE 4

SIGNED: 12/02/2021

REGENCY PLUS, INC.
2000 LOCUST GAP HIGHWAY
MT. CARMEL, PA 17851

SERIES 6212 VINYL CASEMENT WINDOW
36" X 68" – IMPACT
ELEVATION AND GLAZING DETAIL

DRAWN: A.P.	DWG NO. 08-01713	REV B
SCALE NTS	DATE 08/29/12	SHEET 2 OF 4

L. ROBERTO LOMAS P.E.
1432 WOODFORD RD LEWISVILLE, NC 27023
434-688-0609 rllomas@rlomaspe.com



Luis R. Lomas P.E.
TX No.: 101889

REVISIONS			
REV	DESCRIPTION	DATE	APPROVED
B	REVISED PER NEW CODE	11/15/2021	R.L.

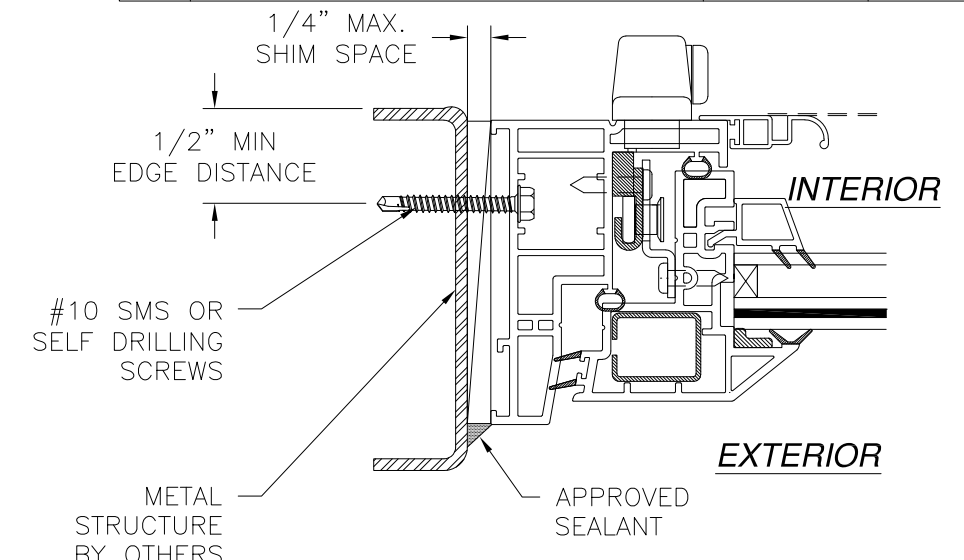
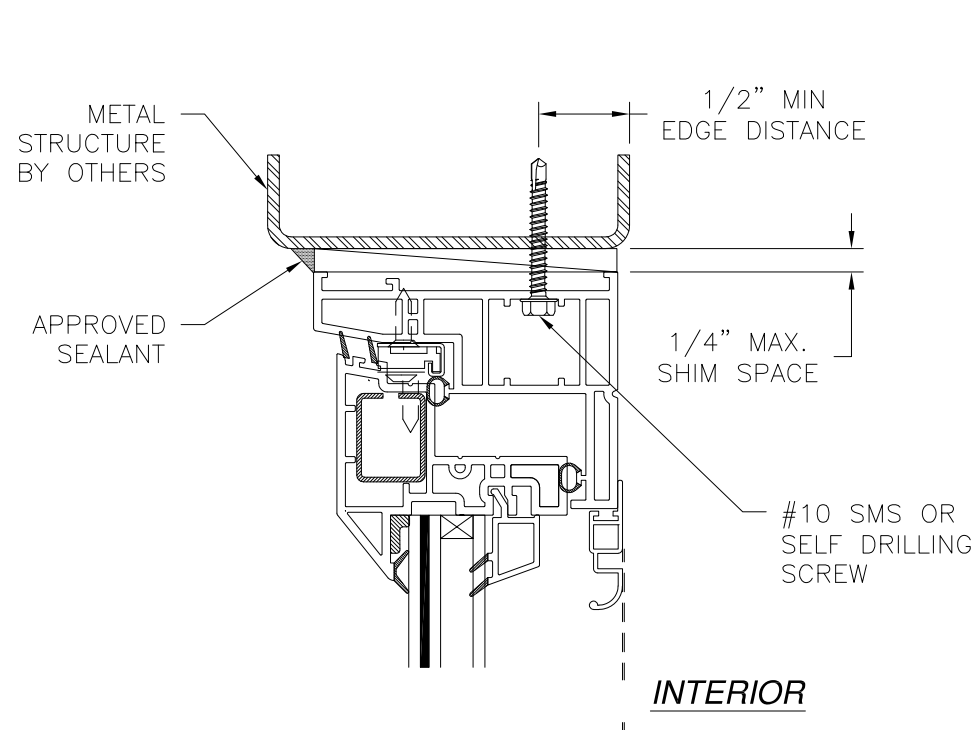
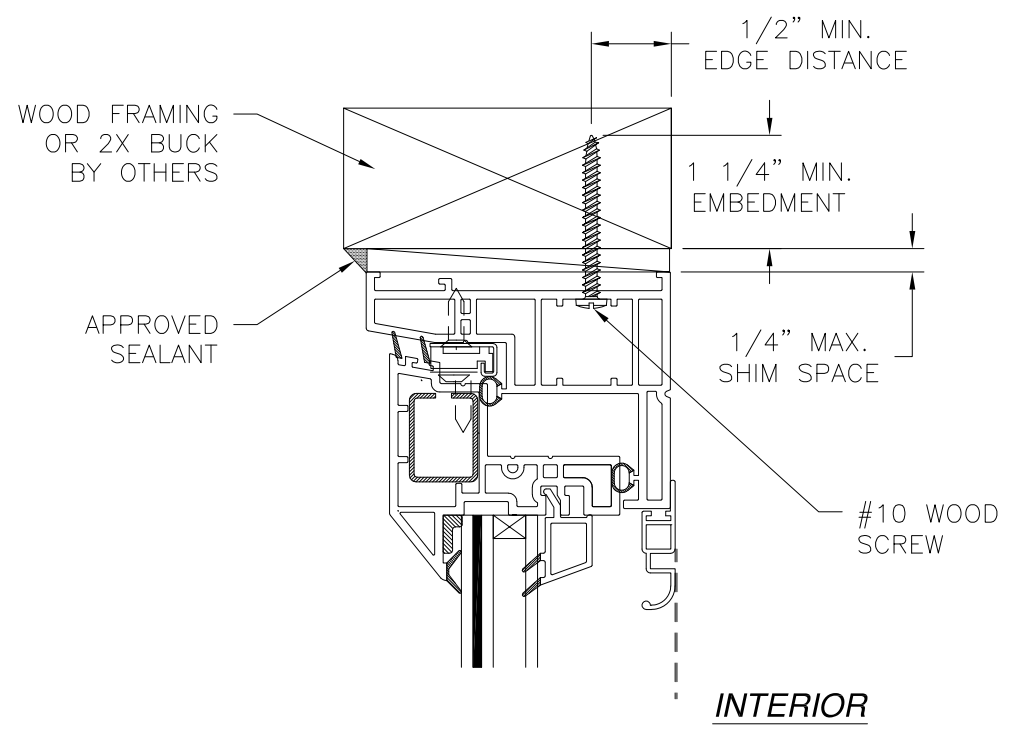

JAMB INSTALLATION DETAIL
METAL STRUCTURE INSTALLATION

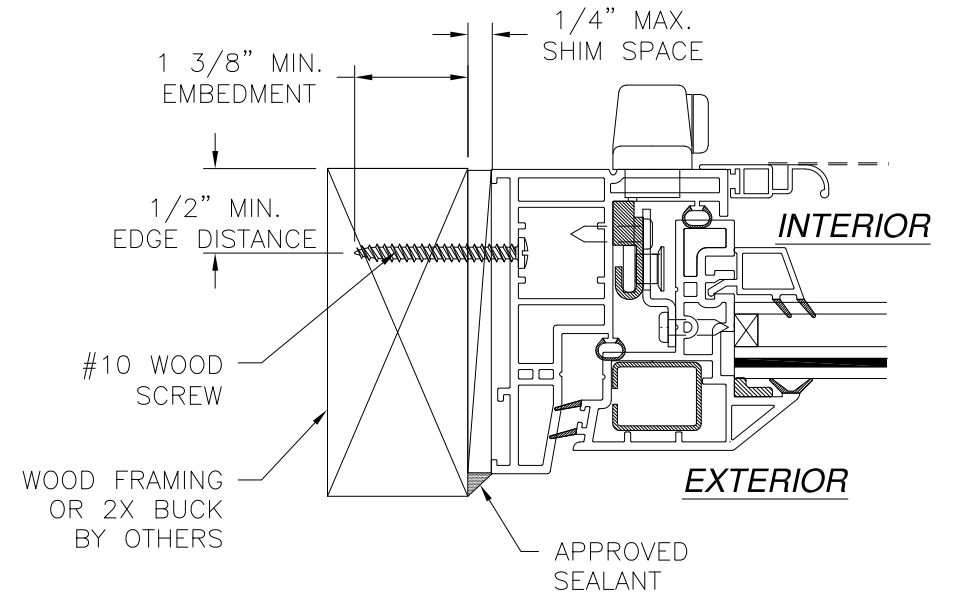
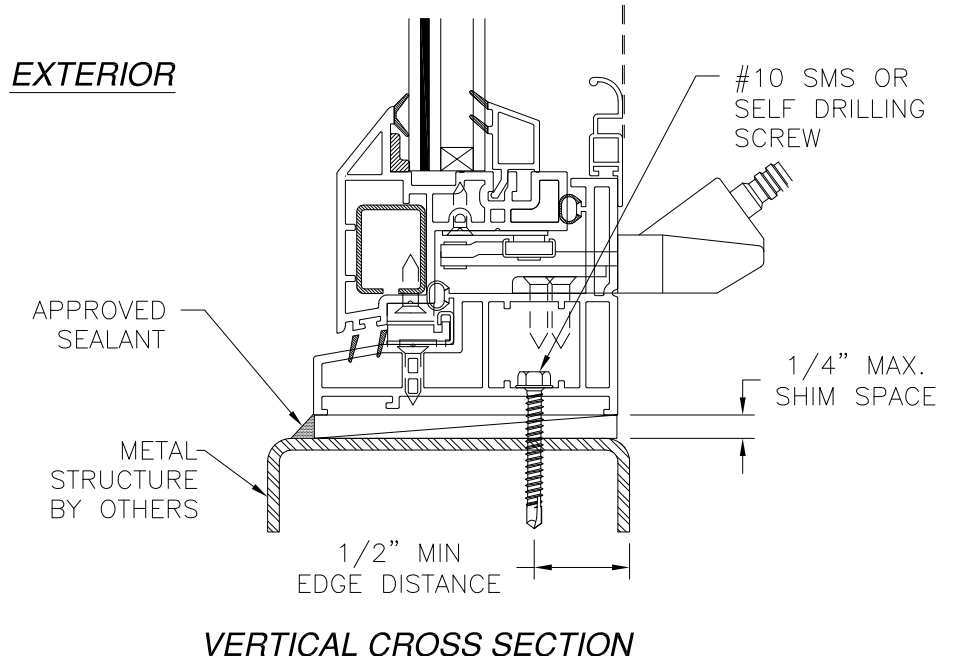
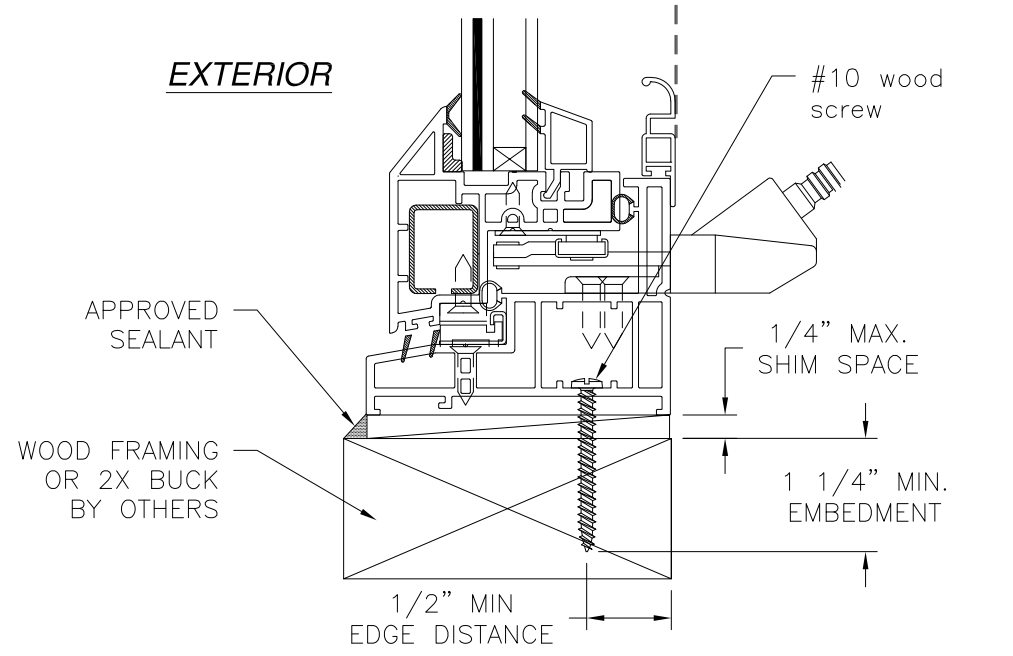

JAMB INSTALLATION DETAIL
WOOD FRAMING OR 2X BUCK INSTALLATION

VERTICAL CROSS SECTION
WOOD FRAMING OR 2X BUCK INSTALLATION

VERTICAL CROSS SECTION
METAL STRUCTURE INSTALLATION

SIGNED: 12/02/2021

- NOTES:**
1. INTERIOR AND EXTERIOR FINISHES, BY OTHERS, NOT SHOWN FOR CLARITY.
 2. PERIMETER AND JOINT SEALANT BY OTHERS TO BE DESIGNED IN ACCORDANCE WITH ASTM E2112

REGENCY PLUS, INC.
2000 LOCUST GAP HIGHWAY
MT. CARMEL, PA 17851

SERIES 6212 VINYL CASEMENT WINDOW
36" X 68" - IMPACT
INSTALLATION DETAILS

DRAWN: A.P.	DWG NO. 08-01713	REV B
SCALE NTS	DATE 08/29/12	SHEET 3 OF 4

L. ROBERTO LOMAS P.E.
1432 WOODFORD RD LEWISVILLE, NC 27023
434-688-0609 rllomas@rlomaspe.com



Luis R. Lomas P.E.
TX No.: 101889

REVISIONS			
REV	DESCRIPTION	DATE	APPROVED
B	REVISED PER NEW CODE	11/15/2021	R.L.

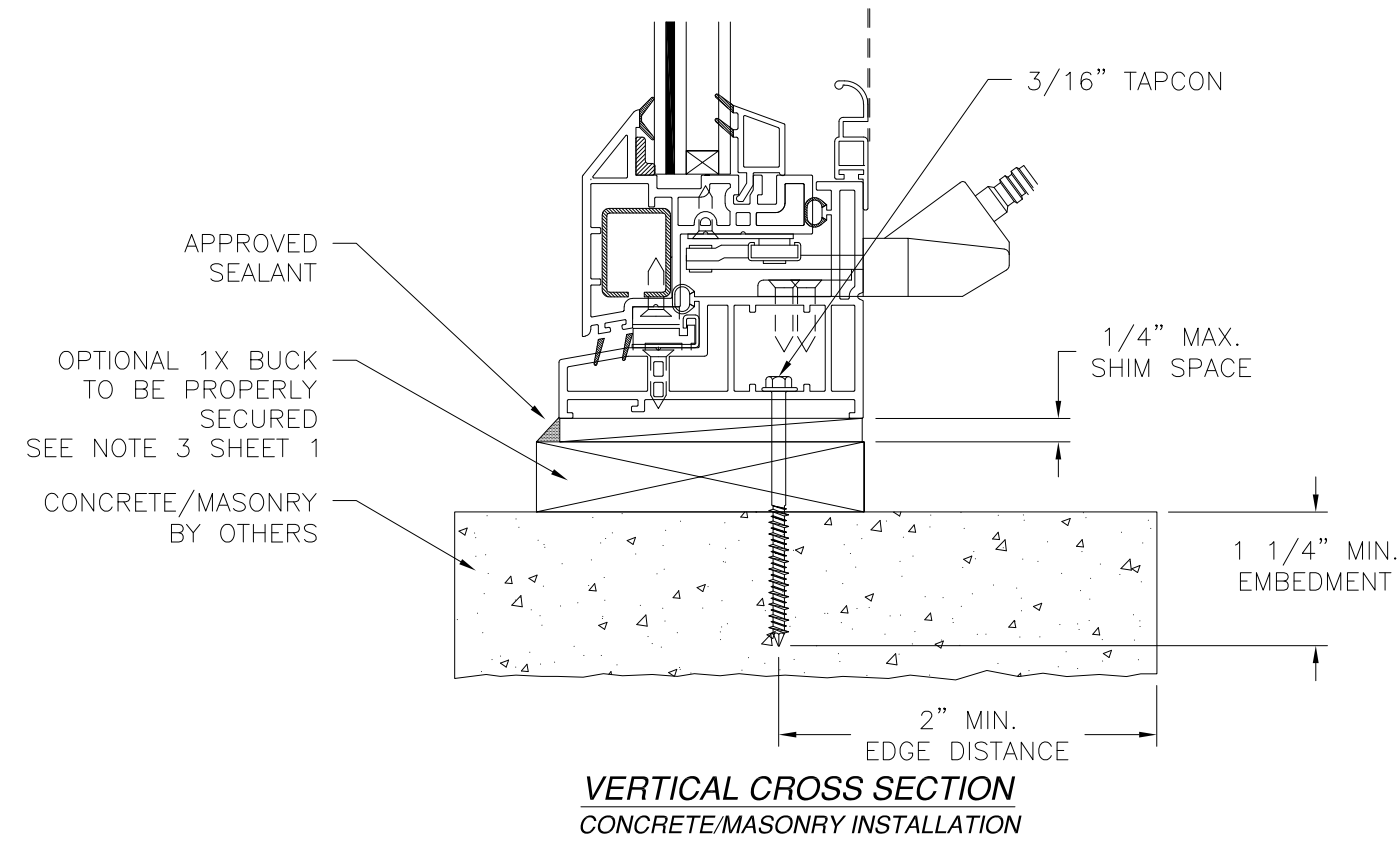
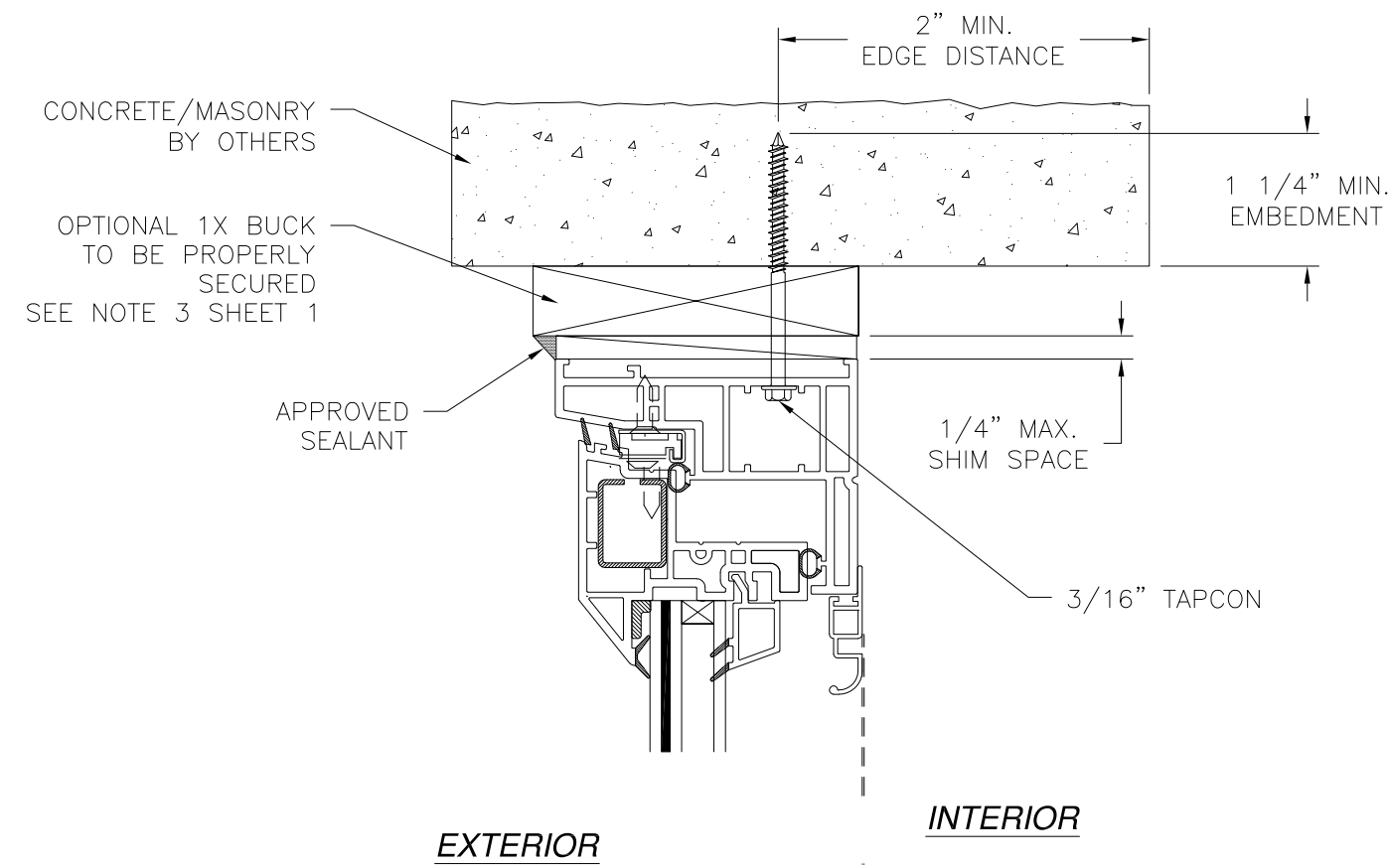

VERTICAL CROSS SECTION
CONCRETE/MASONRY INSTALLATION

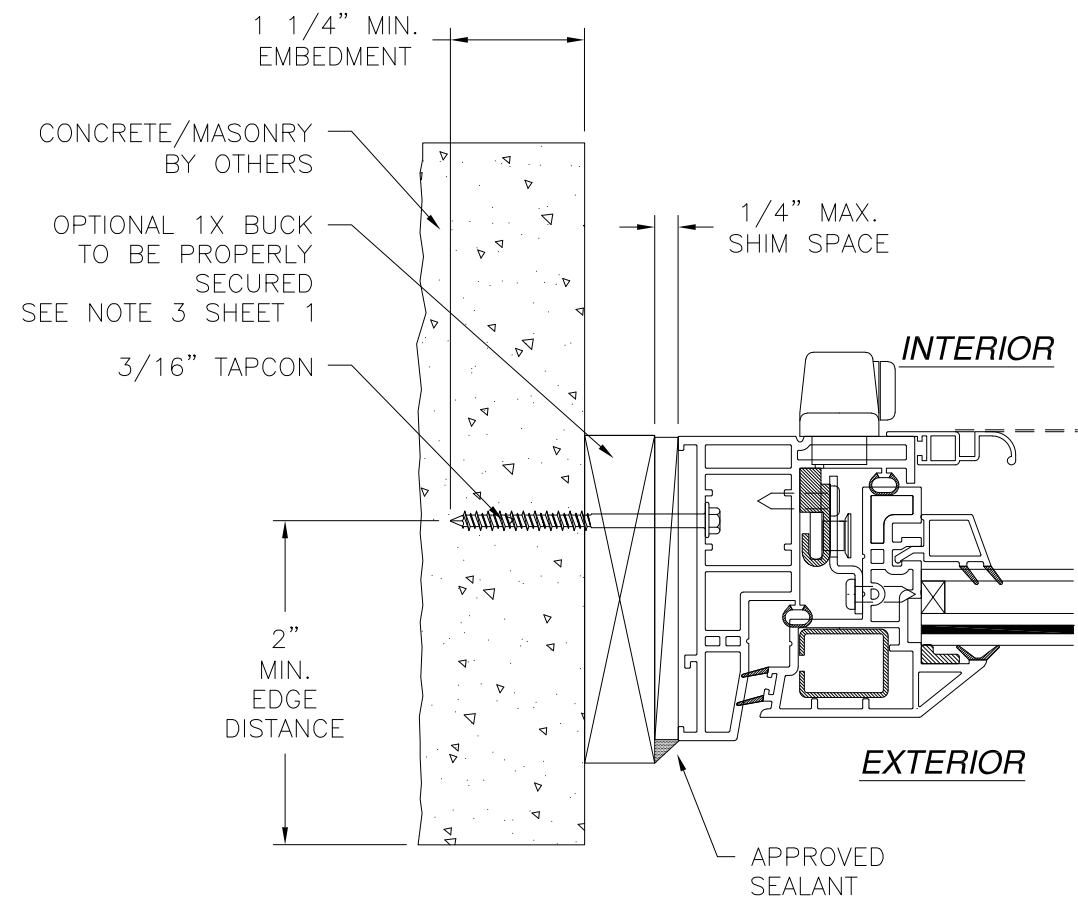

JAMB INSTALLATION DETAIL
CONCRETE/MASONRY INSTALLATION

- NOTES:**
1. INTERIOR AND EXTERIOR FINISHES, BY OTHERS, NOT SHOWN FOR CLARITY.
 2. PERIMETER AND JOINT SEALANT BY OTHERS TO BE DESIGNED IN ACCORDANCE WITH ASTM E2112

SIGNED: 12/02/2021

<p>REGENCY PLUS, INC. 2000 LOCUST GAP HIGHWAY MT. CARMEL, PA 17851</p>		
<p>SERIES 6212 VINYL CASEMENT WINDOW 36" X 68" - IMPACT INSTALLATION DETAILS</p>		
DRAWN: A.P.	DWG NO. 08-01713	REV B
SCALE NTS	DATE 08/29/12	SHEET 4 OF 4
<p>L. ROBERTO LOMAS P.E. 1432 WOODFORD RD LEWISVILLE, NC 27023 434-688-0609 rllomas@rlomaspe.com</p>		



Luis R. Lomas P.E.
TX No.: 101889