

REVISIONS			
REV	DESCRIPTION	DATE	APPROVED
A	REVISED PER NEW REQUIREMENTS	07/08/19	R.L.

NOTES:

1. THE PRODUCT SHOWN HEREIN IS DESIGNED AND MANUFACTURED TO COMPLY WITH REQUIREMENTS OF THE 2006 IBC AND THE 2006 IRC WITH STATE OF TEXAS MODIFICATIONS AND WITH THE 2009 IBC, 2009 IRC, 2012 IBC, 2012 IRC, 2015 IBC AND 2015 IRC.
2. WOOD FRAMING AND MASONRY OPENING TO BE DESIGNED AND ANCHORED TO PROPERLY TRANSFER ALL LOADS TO STRUCTURE. FRAMING AND MASONRY OPENING IS THE RESPONSIBILITY OF THE ARCHITECT OR ENGINEER OF RECORD.
3. 1X BUCK OVER MASONRY/CONCRETE IS OPTIONAL.
4. WHERE SHIM OR BUCK THICKNESS IS LESS THAN 1-1/2" UNITS MUST BE ANCHORED THROUGH THE FRAME IN ACCORDANCE WITH MANUFACTURER'S PUBLISHED INSTALLATION INSTRUCTIONS. ANCHORS SHALL BE SECURELY FASTENED DIRECTLY INTO MASONRY, CONCRETE OR OTHER STRUCTURAL SUBSTRATE MATERIAL.
5. WHERE WOOD BUCK THICKNESS IS 1-1/2" OR GREATER, BUCK SHALL BE SECURELY FASTENED TO MASONRY, CONCRETE OR OTHER STRUCTURAL SUBSTRATE. UNITS MAY BE ANCHORED THROUGH FRAME TO SECURED WOOD BUCK IN ACCORDANCE WITH MANUFACTURER'S PUBLISHED INSTALLATION INSTRUCTIONS.
6. WHERE 1X BUCK IS NOT USED DISSIMILAR MATERIALS MUST BE SEPARATED WITH APPROVED COATING OR MEMBRANE. SELECTION OF COATING OR MEMBRANE IS THE RESPONSIBILITY OF THE ARCHITECT OR ENGINEER OF RECORD.
7. BUCKS SHALL EXTEND BEYOND UNIT FRAME INTERIOR FACE SO THAT FULL FRAME SUPPORT IS PROVIDED.
8. FOR FIN INSTALLATION SHIM AS NEEDED. FOR FRAME INSTALLATION SHIM AS REQUIRED AT EACH ANCHOR LOCATION WITH LOAD BEARING SHIM. SHIM WHERE SPACE OF 1/16" OR GREATER OCCURS. MAXIMUM ALLOWABLE SHIM STACK TO BE 1/4".
9. SHIMS SHALL BE LOCATED, APPLIED AND MADE FROM MATERIALS AND THICKNESS CAPABLE OF SUSTAINING APPLICABLE LOADS.
10. WIND LOAD DURATION FACTOR Cd=1.6 WAS USED FOR WOOD ANCHOR CALCULATIONS.
11. FRAME MATERIAL: EXTRUDED RIGID PVC.
12. UNITS MUST BE GLAZED PER ASTM E1300-04/09.
13. APPROVED IMPACT PROTECTIVE SYSTEM IS REQUIRED FOR THIS PRODUCT IN WIND BORNE DEBRIS REGIONS.
14. FOR ANCHORING THROUGH FIN INTO WOOD FRAMING OR 2X BUCK USE #8 WOOD SCREWS WITH SUFFICIENT LENGTH TO ACHIEVE A 1 1/4" MINIMUM EMBEDMENT INTO SUBSTRATE. LOCATE ANCHORS AS SHOWN IN ELEVATIONS AND INSTALLATION DETAILS.
15. FOR ANCHORING THROUGH FRAME INTO WOOD FRAMING OR 2X BUCK USE #8 WOOD SCREWS WITH SUFFICIENT LENGTH TO ACHIEVE A 1 1/4" MINIMUM EMBEDMENT INTO SUBSTRATE. LOCATE ANCHORS AS SHOWN IN ELEVATIONS AND INSTALLATION DETAILS.
16. FOR ANCHORING THROUGH FRAME INTO MASONRY/CONCRETE USE 3/16" TAPCONS WITH SUFFICIENT LENGTH TO ACHIEVE A 1 1/4" MINIMUM EMBEDMENT INTO SUBSTRATE WITH 2" MINIMUM EDGE DISTANCE. LOCATE ANCHORS AS SHOWN IN ELEVATIONS AND INSTALLATION DETAILS.
17. FOR ANCHORING THROUGH FRAME INTO METAL STRUCTURE USE #8 SMS OR SELF DRILLING SCREWS WITH SUFFICIENT LENGTH TO ACHIEVE 3 THREADS MINIMUM BEYOND STRUCTURE INTERIOR WALL. LOCATE ANCHORS AS SHOWN IN ELEVATIONS AND INSTALLATION DETAILS.
18. ALL FASTENERS TO BE CORROSION RESISTANT.
19. INSTALLATION ANCHORS SHALL BE INSTALLED IN ACCORDANCE WITH ANCHOR MANUFACTURER'S INSTALLATION INSTRUCTIONS AND ANCHORS SHALL NOT BE USED IN SUBSTRATES WITH STRENGTHS LESS THAN THE MINIMUM STRENGTH SPECIFIED BELOW:
 - A. WOOD: MINIMUM SPECIFIC GRAVITY OF G=0.42
 - B. CONCRETE: MINIMUM COMPRESSIVE STRENGTH OF 2,000 PSI.
 - C. MASONRY: HOLLOW/FILLED BLOCK PER ASTM C90 WITH Fm=2,000PSI MINIMUM.
 - D. METAL STRUCTURE: STEEL 18GA (.048") FY=33KSI/FU=52KSI OR ALUMINUM 6063-T5 FU=30KSI .048" THICK MINIMUM

SIGNED: 07/23/2019

TABLE OF CONTENTS	
SHEET NO.	DESCRIPTION
1	NOTES
2	ELEVATIONS
3 - 5	INSTALLATION DETAILS
6	COMPONENTS

WINDOW MART 5760 ALBERT PIKE ROYAL, AR 71968		
SERIES 4325 VINYL CASEMENT WINDOW 36" X 72" NON-IMPACT NOTES		
DRAWN: N.G.	DWG NO. 08-02760	REV A
SCALE NTS	DATE 07/16/15	SHEET 1 OF 6
L. ROBERTO LOMAS P.E. 1432 WOODFORD RD LEWISVILLE, NC 27023 434-688-0609 rllomas@lrlomaspe.com		



Luis R. Lomas P.E.
TX No.: 101889

REVISIONS			
REV	DESCRIPTION	DATE	APPROVED
A	REVISED PER NEW REQUIREMENTS	07/08/19	R.L.

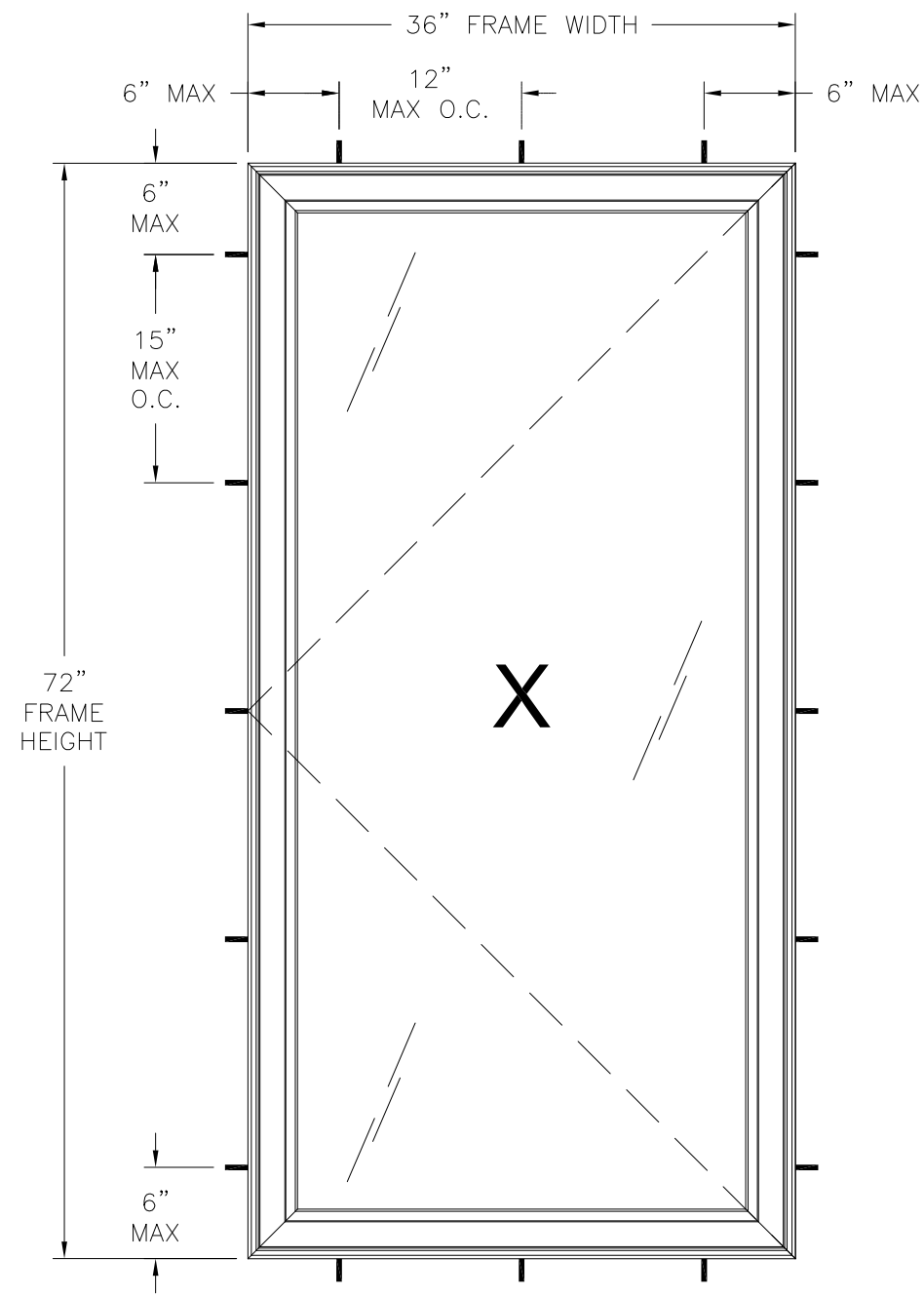

4325 CASEMENT WINDOW
EXTERIOR VIEW
FRAME INSTALLATION

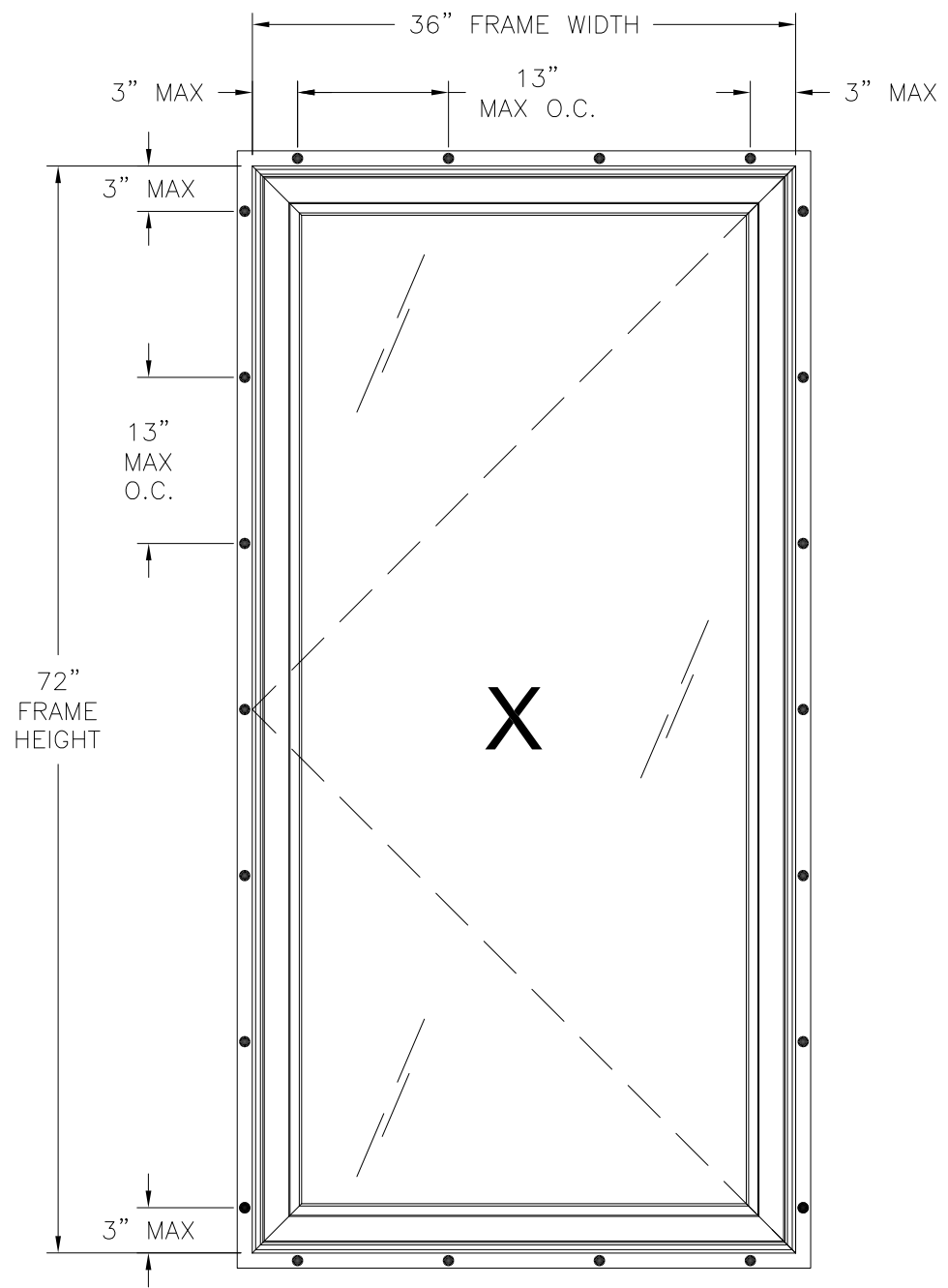

4325 CASEMENT WINDOW
EXTERIOR VIEW
FIN INSTALLATION

- NOTES:**
- SASH SIZE: 34 3/8" X 70 3/8"
 - D.L.O. SIZE: 29 3/32" X 67 1/4"

DESIGN PRESSURE RATING	IMPACT RATING
±40.0PSF	NONE

36" X 72" UNIT SHOWN. OTHER SIZES APPROVED AS LONG AS FRAME AREA DOES NOT EXCEED 18.0 FT²

HARDWARE SCHEDULE	
A.	(1) LEVER LOCK SYSTEM WITH METAL KEEPER AT RIGHT JAMB/STILE, 4", 25 1/2", 45" AND 64 1/2" UP FROM THE BOTTOM
B.	(1 PAIR) STEEL SNUBBER AT LEFT JAMB/STILE, AT MIDSPAN
C.	(2 PAIR) STEEL SNUBBER AT LEFT JAMB/STILE, ONE 13" IN FROM EACH END
D.	(2) SINGLE ARM CONCEALED HINGE AT HEAD/TOP RAIL, SILL/BOTTOM RAIL
E.	(1) DUAL ARM ROTARY OPERATOR AT SILL AT MIDSPAN
F.	ALUMINUM CUSTOM-SHAPED REINFORCEMENT (10500006) AT SASH STILES

WINDOW MART
5760 ALBERT PIKE
ROYAL, AR 71968

SERIES 4325 VINYL CASEMENT WINDOW
36" X 72" NON-IMPACT
ELEVATIONS

DRAWN: N.G.	DWG NO. 08-02760	REV A
SCALE NTS	DATE 07/16/15	SHEET 2 OF 6

L. ROBERTO LOMAS P.E.
1432 WOODFORD RD LEWISVILLE, NC 27023
434-688-0609 rllomas@lrlomaspe.com

SIGNED: 07/23/2019



Luis R. Lomas P.E.
TX No.: 101889

REVISIONS			
REV	DESCRIPTION	DATE	APPROVED
A	REVISED PER NEW REQUIREMENTS	07/08/19	R.L.

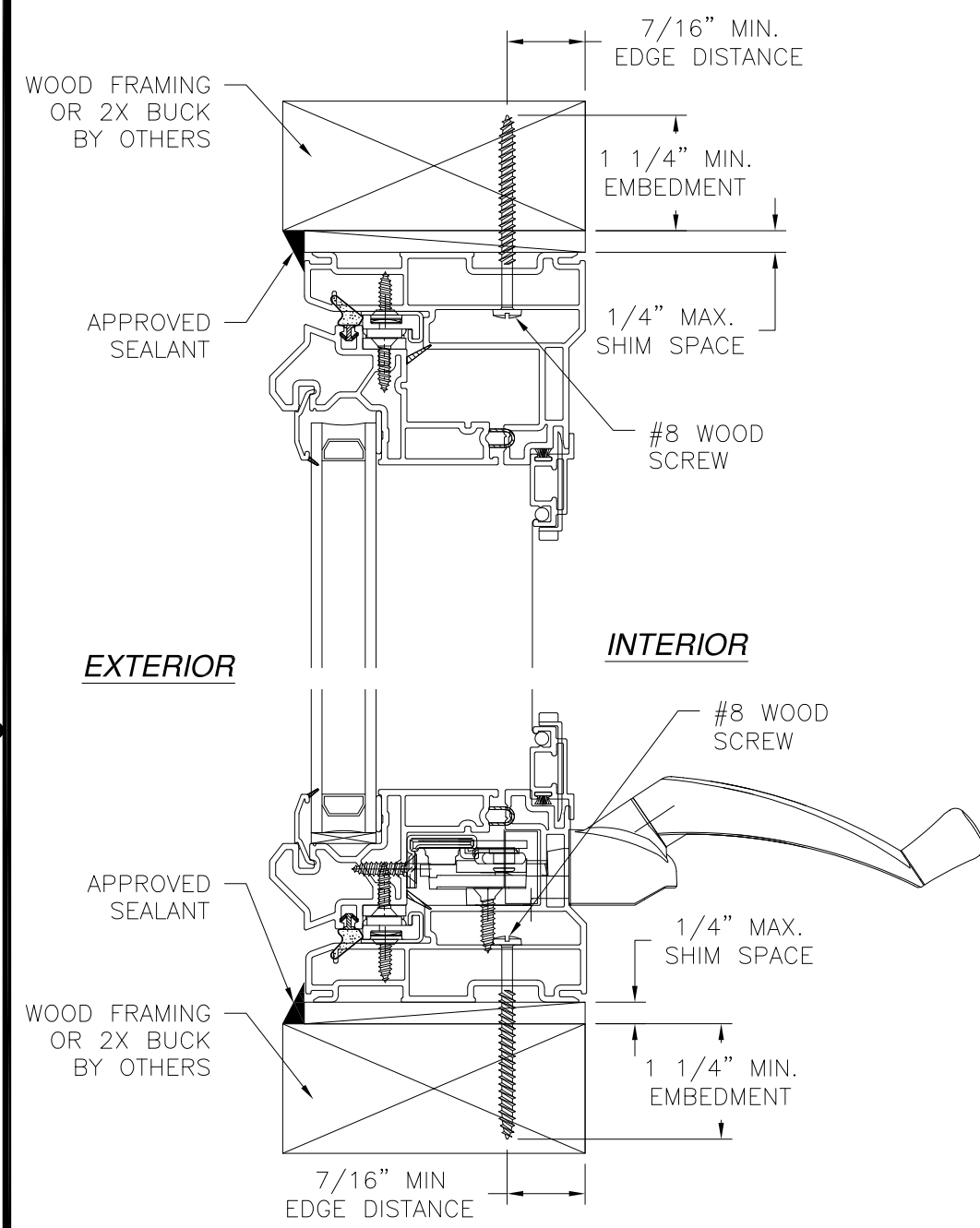

VERTICAL CROSS SECTION
WOOD FRAMING OR 2X BUCK INSTALLATION

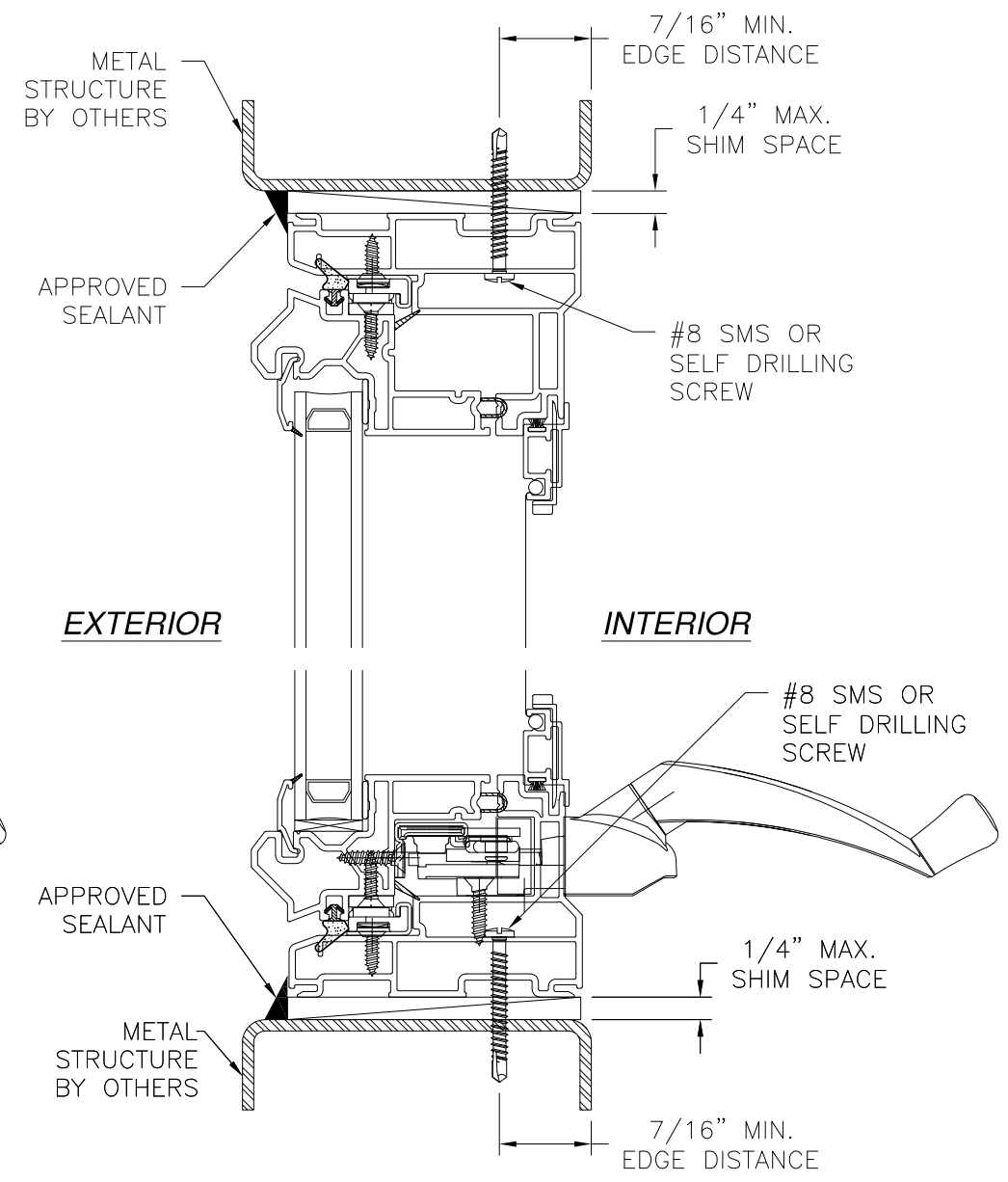

VERTICAL CROSS SECTION
METAL STRUCTURE INSTALLATION

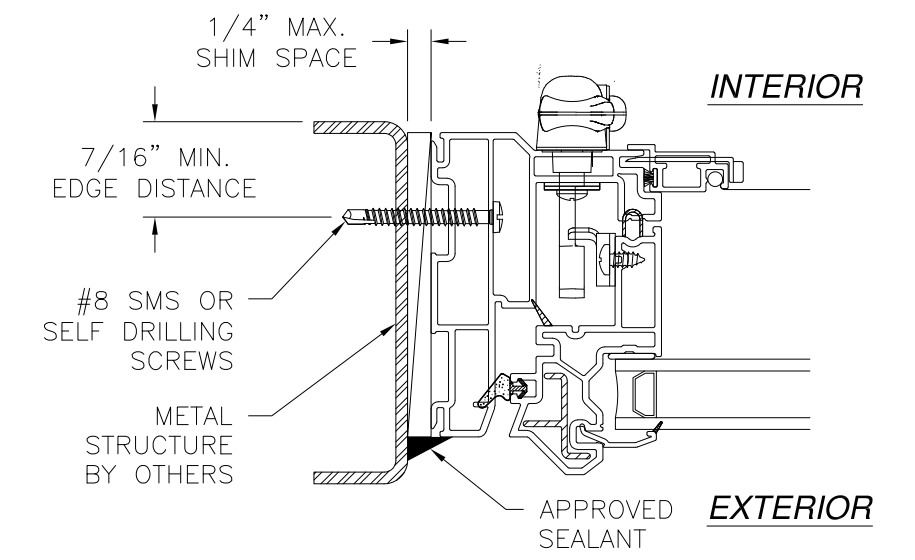

JAMB INSTALLATION DETAIL
METAL STRUCTURE INSTALLATION

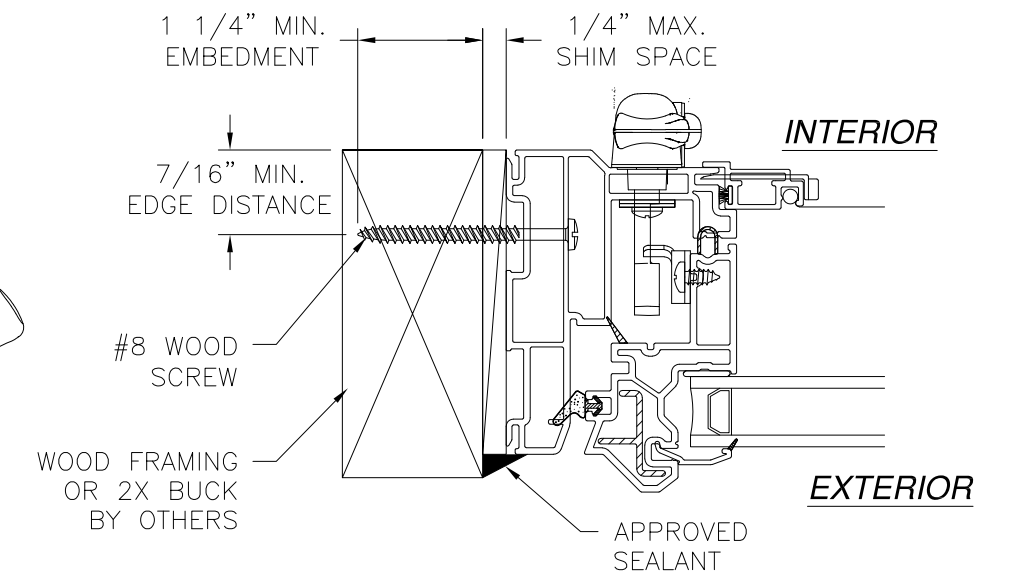

JAMB INSTALLATION DETAIL
WOOD FRAMING OR 2X BUCK INSTALLATION

SIGNED: 07/23/2019

- NOTES:
 1. INTERIOR AND EXTERIOR FINISHES, BY OTHERS, NOT SHOWN FOR CLARITY.
 2. PERIMETER AND JOINT SEALANT BY OTHERS TO BE DESIGNED IN ACCORDANCE WITH ASTM E2112

WINDOW MART 5760 ALBERT PIKE ROYAL, AR 71968		
SERIES 4325 VINYL CASEMENT WINDOW 36" X 72" NON-IMPACT INSTALLATION DETAILS		
DRAWN: N.G.	DWG NO. 08-02760	REV A
SCALE NTS	DATE 07/16/15	SHEET 3 OF 6
L. ROBERTO LOMAS P.E. 1432 WOODFORD RD LEWISVILLE, NC 27023 434-688-0609 rllomas@rlomaspe.com		



Luis R. Lomas P.E.
TX No.: 101889

REVISIONS			
REV	DESCRIPTION	DATE	APPROVED
A	REVISED PER NEW REQUIREMENTS	07/08/19	R.L.

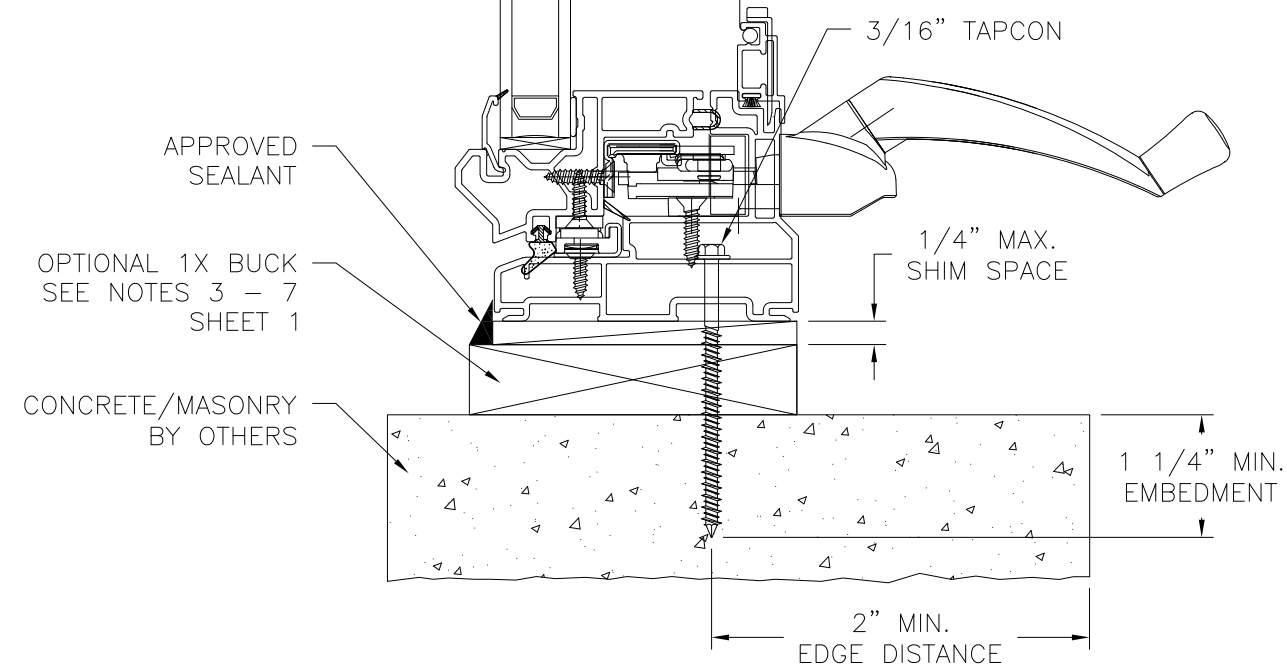
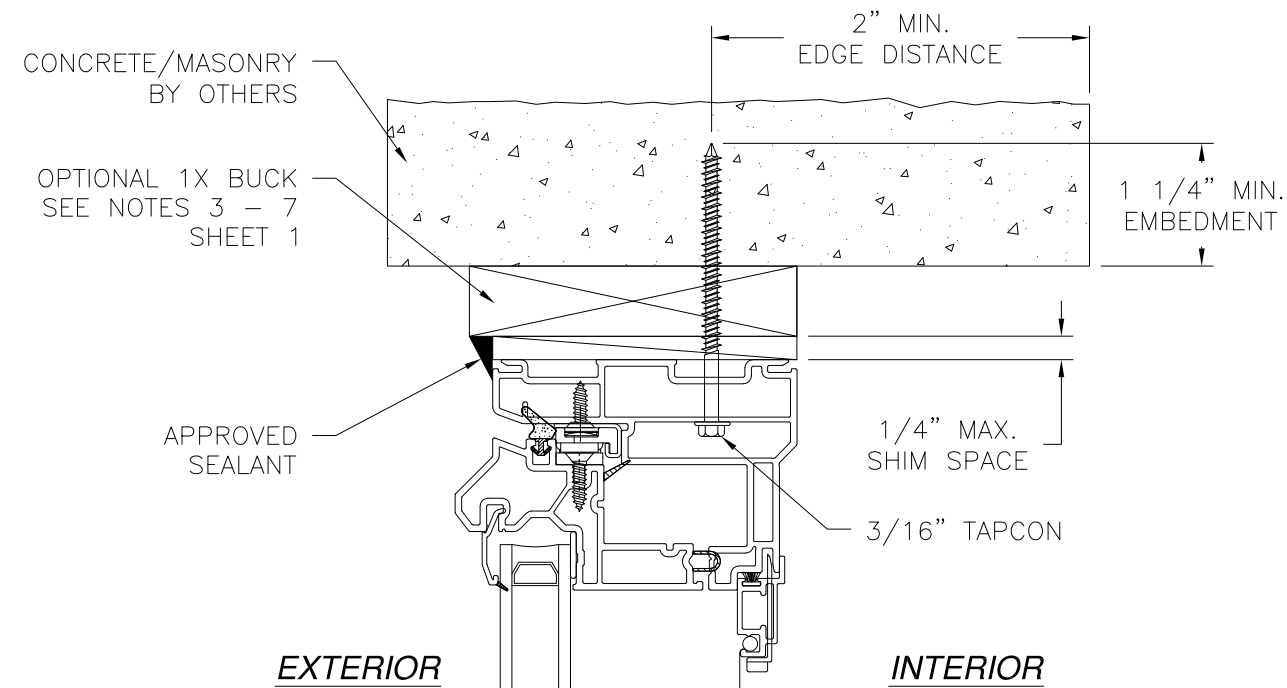

**VERTICAL CROSS SECTION
CONCRETE/MASONRY INSTALLATION**

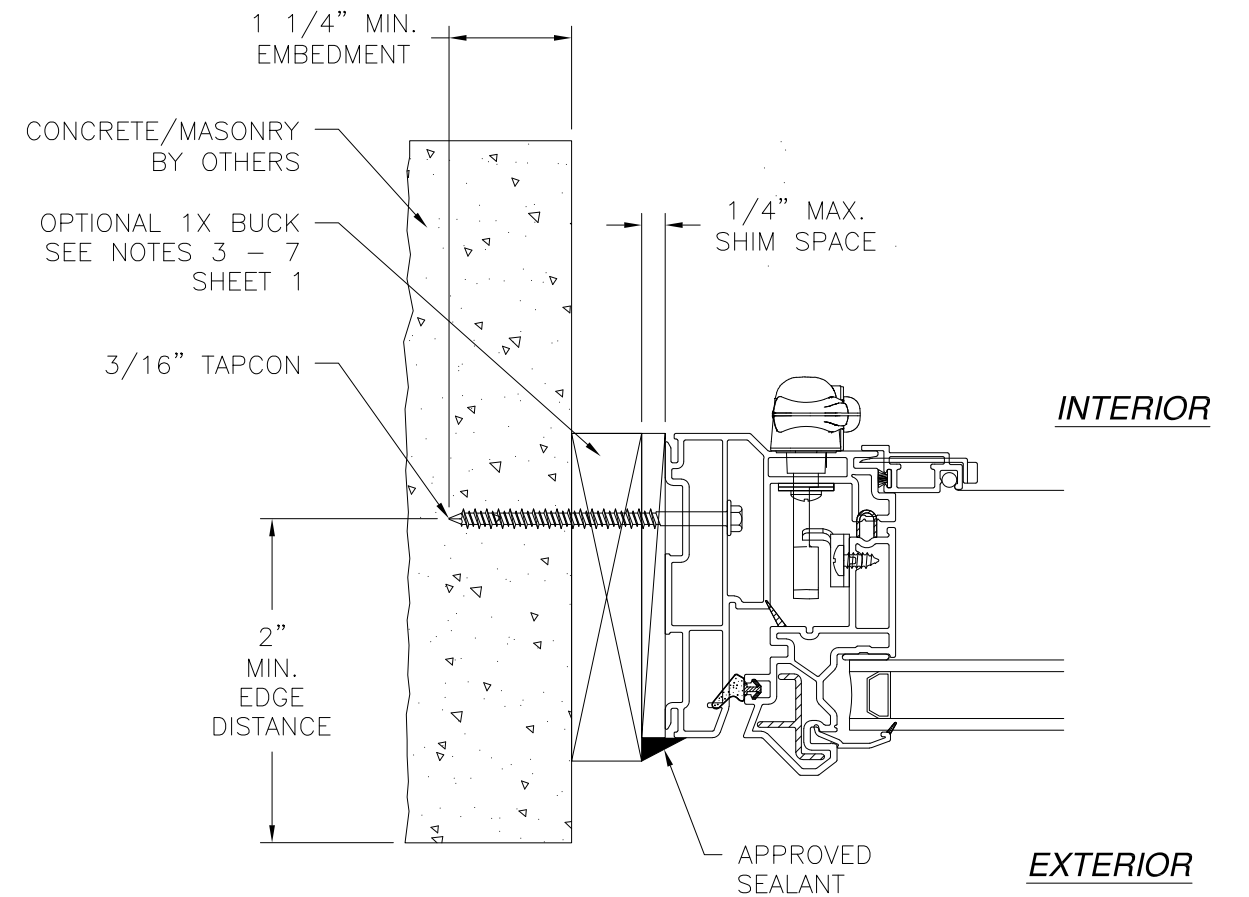

**JAMB INSTALLATION DETAIL
CONCRETE/MASONRY INSTALLATION**

- NOTES:**
1. INTERIOR AND EXTERIOR FINISHES, BY OTHERS, NOT SHOWN FOR CLARITY.
 2. PERIMETER AND JOINT SEALANT BY OTHERS TO BE DESIGNED IN ACCORDANCE WITH ASTM E2112

SIGNED: 07/23/2019

WINDOW MART 5760 ALBERT PIKE ROYAL, AR 71968		
SERIES 4325 VINYL CASEMENT WINDOW 36" X 72" NON-IMPACT INSTALLATION DETAILS		
DRAWN: N.G.	DWG NO. 08-02760	REV A
SCALE NTS	DATE 07/16/15	SHEET 4 OF 6
L. ROBERTO LOMAS P.E. 1432 WOODFORD RD LEWISVILLE, NC 27023 434-688-0609 rllomas@rlomaspe.com		



Luis R. Lomas P.E.
TX No.: 101889

REVISIONS			
REV	DESCRIPTION	DATE	APPROVED
A	REVISED PER NEW REQUIREMENTS	07/08/19	R.L.

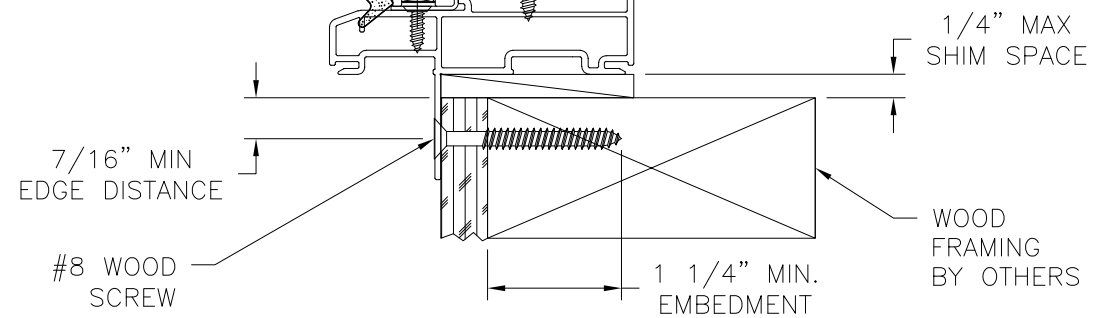
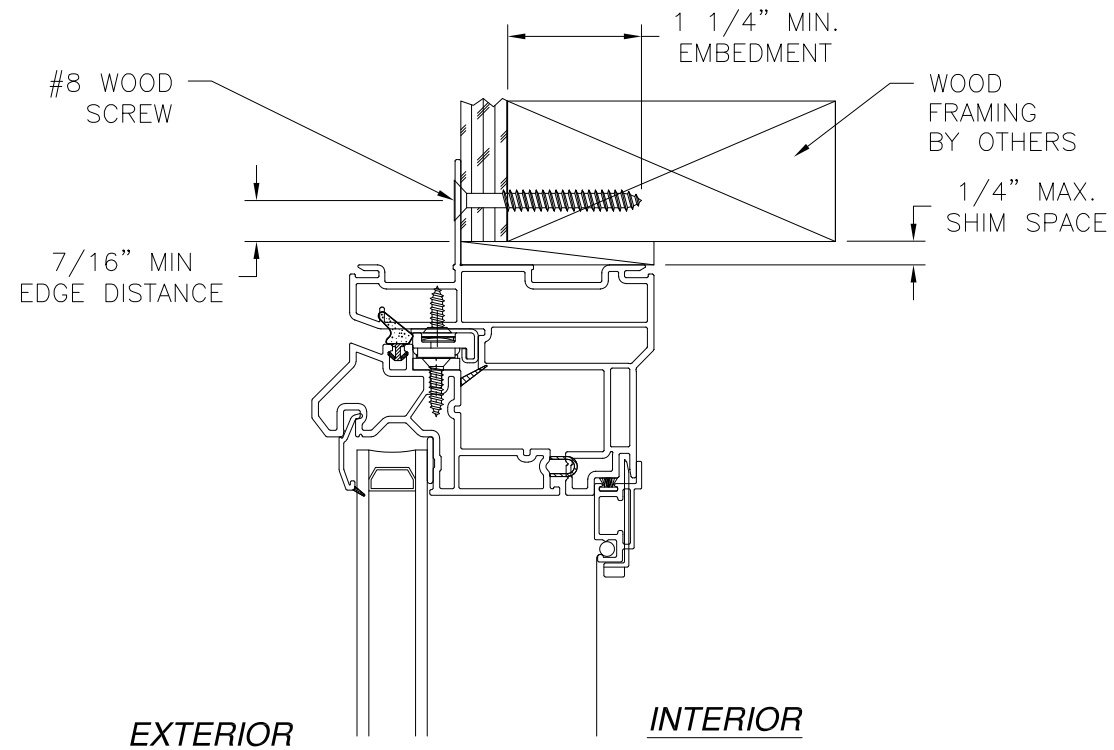

VERTICAL CROSS SECTION
WOOD FRAMING OR 2X BUCK INSTALLATION

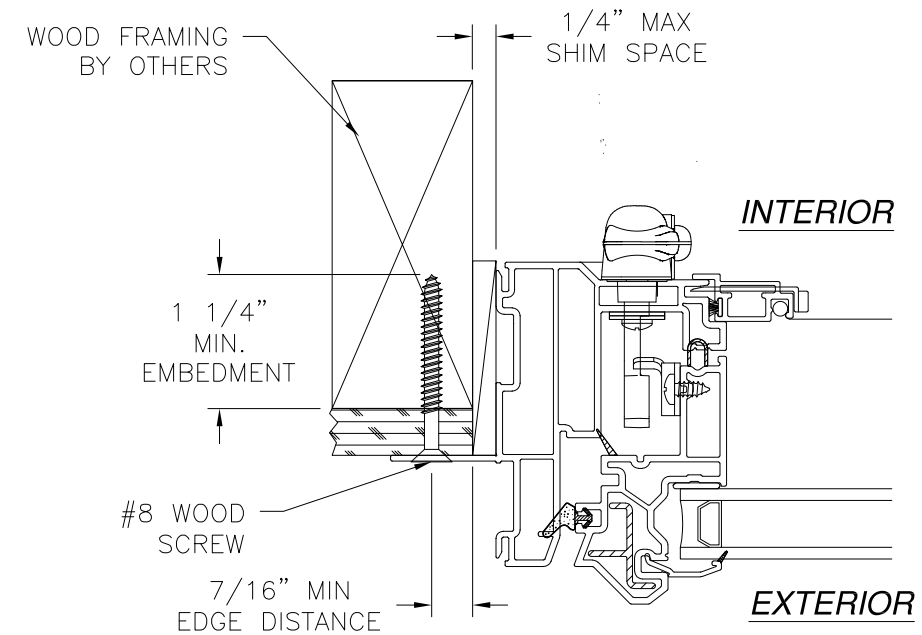

JAMB INSTALLATION DETAIL
WOOD FRAMING OR 2X BUCK INSTALLATION

- NOTES:**
1. INTERIOR AND EXTERIOR FINISHES, BY OTHERS, NOT SHOWN FOR CLARITY.
 2. PERIMETER AND JOINT SEALANT BY OTHERS TO BE DESIGNED IN ACCORDANCE WITH ASTM E2112

SIGNED: 07/23/2019

WINDOW MART 5760 ALBERT PIKE ROYAL, AR 71968		
SERIES 4325 VINYL CASEMENT WINDOW 36" X 72" NON-IMPACT FIN INSTALLATION DETAILS		
DRAWN: N.G.	DWG NO. 08-02760	REV A
SCALE NTS	DATE 07/16/15	SHEET 5 OF 6
L. ROBERTO LOMAS P.E. 1432 WOODFORD RD LEWISVILLE, NC 27023 434-688-0609 rllomas@lrlomaspe.com		



Luis R. Lomas P.E.
TX No.: 101889

REVISIONS			
REV	DESCRIPTION	DATE	APPROVED
A	REVISED PER NEW REQUIREMENTS	07/08/19	R.L.

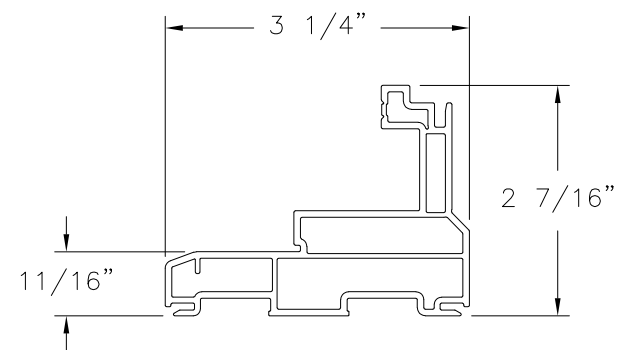

MAIN FRAME
EXTRUDED PVC (10008056)

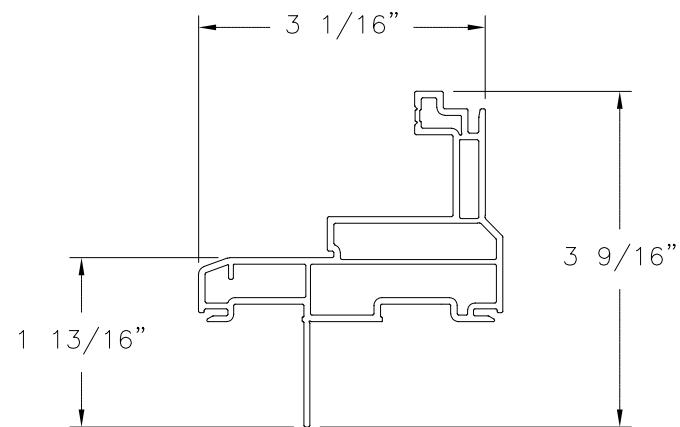

**MAIN FRAME
FIN INSTALLATION**
EXTRUDED PVC (10008056)

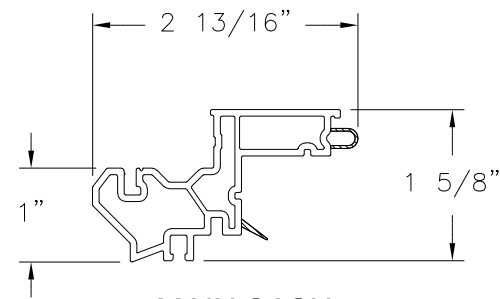

MAIN SASH
EXTRUDED PVC (10005484)

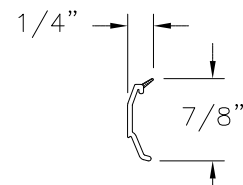

GLAZING BEAD
EXTRUDED PVC (10005473)

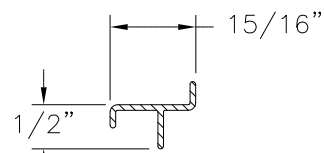

SASH REINFORCEMENT
ALUMINUM 6063-T5 (10500006)

SIGNED: 07/23/2019

WINDOW MART 5760 ALBERT PIKE ROYAL, AR 71968		
SERIES 4325 VINYL CASEMENT WINDOW 36" X 72" NON-IMPACT COMPONENTS		
DRAWN: N.G.	DWG NO. 08-02760	REV A
SCALE NTS	DATE 07/16/15	SHEET 6 OF 6
L. ROBERTO LOMAS P.E. 1432 WOODFORD RD LEWISVILLE, NC 27023 434-688-0609 rllomas@lrlomaspe.com		



Luis R. Lomas P.E.
TX No.: 101889