

DP RATING	NON-IMPACT RESISTANT
SEE TABLE 1	

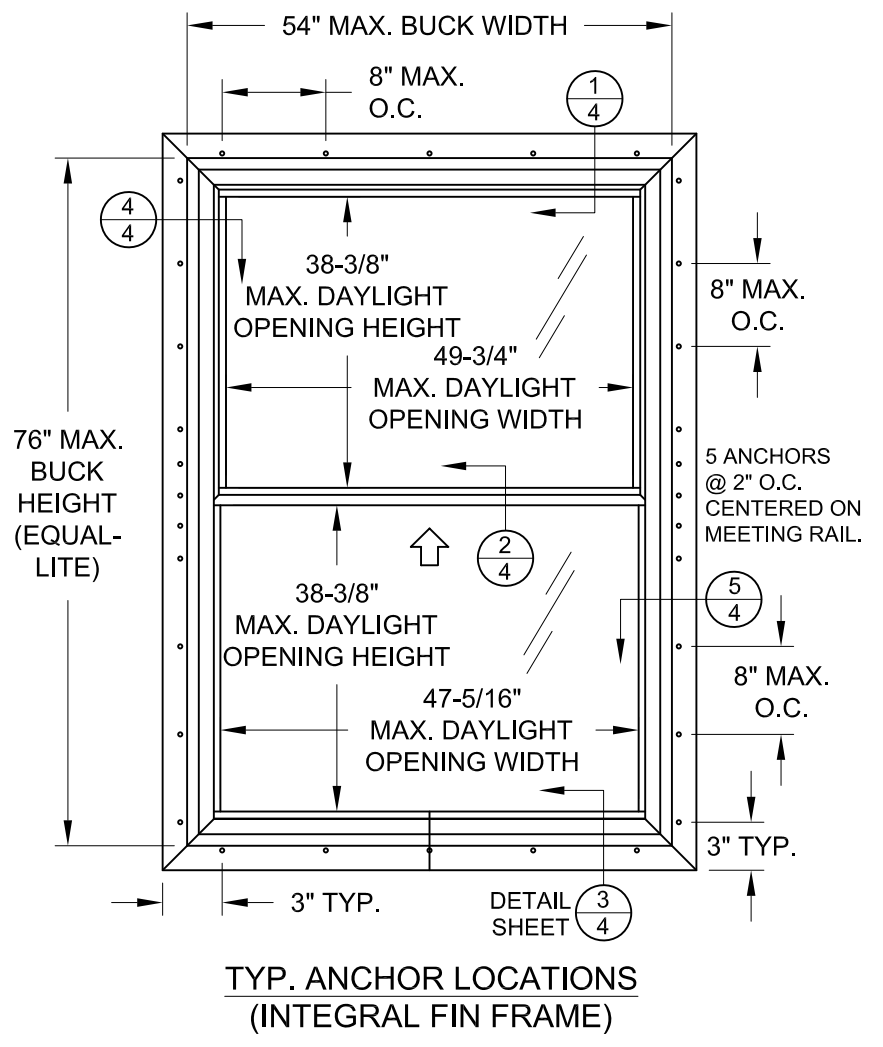

A. LYNN MILLER, P.E., P.E.# 106954

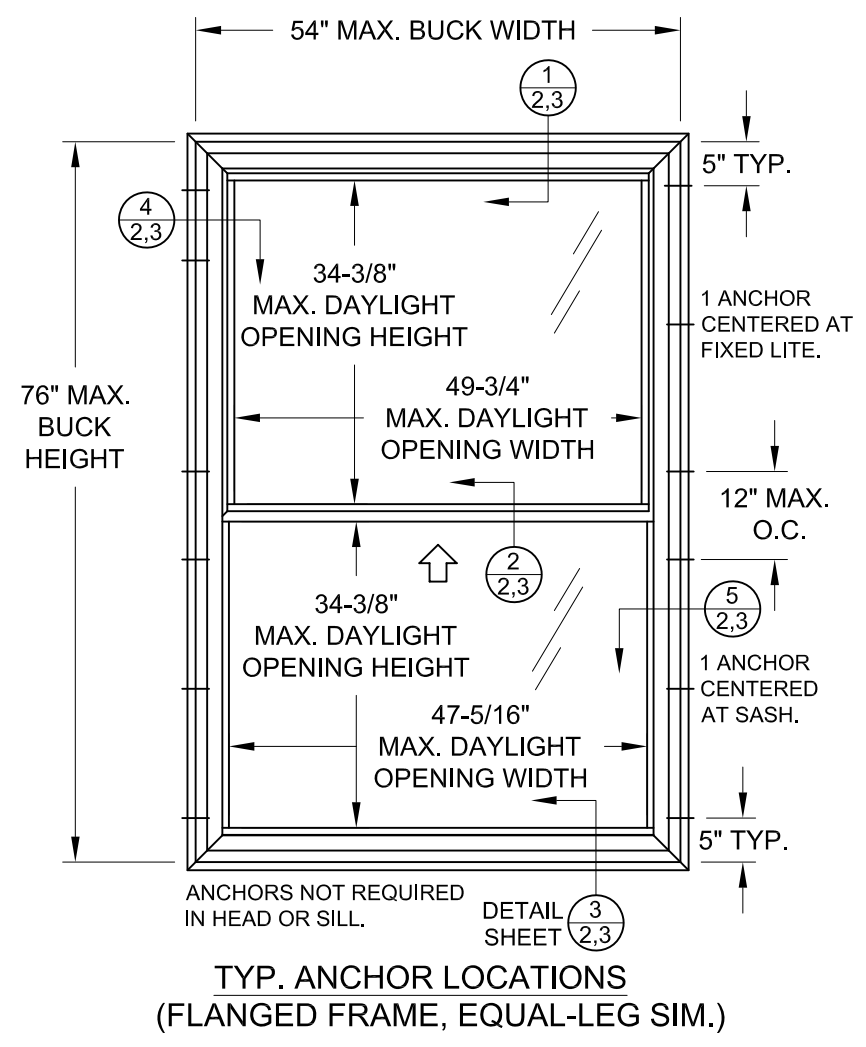

NewSouth WINDOW SOLUTIONS SERIES 9400 SINGLE HUNG, TILT WINDOW, NON-IMPACT RESISTANT, FLANGE, EQUAL-LEG & FIN FRAMES

- 1) THIS PRODUCT HAS BEEN DESIGNED & TESTED TO COMPLY WITH THE REQUIREMENTS OF THE INTERNATIONAL RESIDENTIAL CODE (IRC), AND THE INTERNATIONAL BUILDING CODE (IBC).
- 2) SHUTTERS ARE REQUIRED WHEN USED IN WIND-BORNE DEBRIS REGIONS.
- 3) MASONRY ANCHORS MAY BE USED INTO WOOD. ALL WOOD BUCKS LESS THAN 1-1/2" THICK ARE TO BE CONSIDERED 1X INSTALLATIONS. 1X WOOD BUCKS ARE OPTIONAL IF UNIT IS INSTALLED DIRECTLY TO SUBSTRATE. WOOD BUCKS DEPICTED AS 2X ARE 1-1/2" THICK OR GREATER.
- 4) ANCHOR EMBEDMENT TO BASE MATERIAL SHALL BE BEYOND WALL DRESSING OR STUCCO. USE ANCHORS OF SUFFICIENT LENGTH.

- 5) MAX. 1/4" SHIMS ARE REQUIRED AT EACH ANCHOR LOCATION WHERE THE PRODUCT IS NOT FLUSH TO THE SUBSTRATE. USE SHIMS CAPABLE OF TRANSFERRING APPLIED LOADS.
- 6) THE ANCHORAGE METHODS SHOWN HAVE BEEN DESIGNED TO RESIST THE WIND LOADS CORRESPONDING TO THE REQUIRED DESIGN PRESSURE. THE 33-1/3% STRESS INCREASE HAS NOT BEEN USED IN THE DESIGN OF THIS PRODUCT. THE 1.6 LOAD DURATION FACTOR WAS USED FOR THE EVALUATION OF ANCHORS INTO WOOD. ANCHORS THAT COME INTO CONTACT WITH OTHER DISSIMILAR MATERIALS SHALL MEET THE REQUIREMENTS OF THE INTERNATIONAL BUILDING CODE FOR CORROSION RESISTANCE.

TABLE 1: DESIGN PRESSURES

Buck Width	Buck Height	Configuration	Frame Type	Glass Type	Design Pressure		Certification
					(+) psf	(-) psf	
54"	76"	Equal-lite	All	1 or 2	50.0	50.0	NI011864, NI011864.01
36"	72"	Equal-lite	All	1 or 2	65.0	75.0	NI011864.02, NI011864.03

FOR SIZES NOT SHOWN, ROUND UP TO THE NEXT AVAILABLE WIDTH OR HEIGHT DIMENSION. FOR GLASS TYPES, SEE SHEET 6.

PREPARED BY: A. LYNN MILLER, P.E. REGISTRATION #F-23136
1070 TECHNOLOGY DR
N. VENICE, FL 34275
(941)-480-1600

REGISTRATION #F-23136	BY: 9400 SERIES SINGLE HUNG, NI
COPYRIGHT © 2023 NEWSOUTH WINDOW SOLUTIONS LIMITED LICENSE TO MAKE COPIES FOR PERMITTING	REVISION: LY
	DATE: 2/24
	#: 1
	DATE: 02/24/2023
	SCALE: NTS
	BY: LOGAN YODER
	DRAWING #: SH9400-TDI-NI
	SHEET: 1 OF 6



A. LYNN MILLER, P.E., P.E.# 106954

REGISTRATION #F-23136
 PREPARED BY: A. LYNN MILLER, P.E.
 1070 TECHNOLOGY DR
 N. VENICE, FL 34275
 (941)-480-1600

COPYRIGHT © 2023
 NEWSOUTH WINDOW SOLUTIONS
 LIMITED LICENSE TO MAKE
 COPIES FOR PERMITTING

BY: 9400 SERIES SINGLE HUNG, NI
 LY
 REVISION: MINOR EDITORIAL UPDATES
 DATE: 2/24
 # 1
 DATE: 02/24/2023
 SCALE: NTS
 BY: LOGAN YODER
 DRAWING #: SH9400-TDI-NI
 SHEET: 2 OF 6

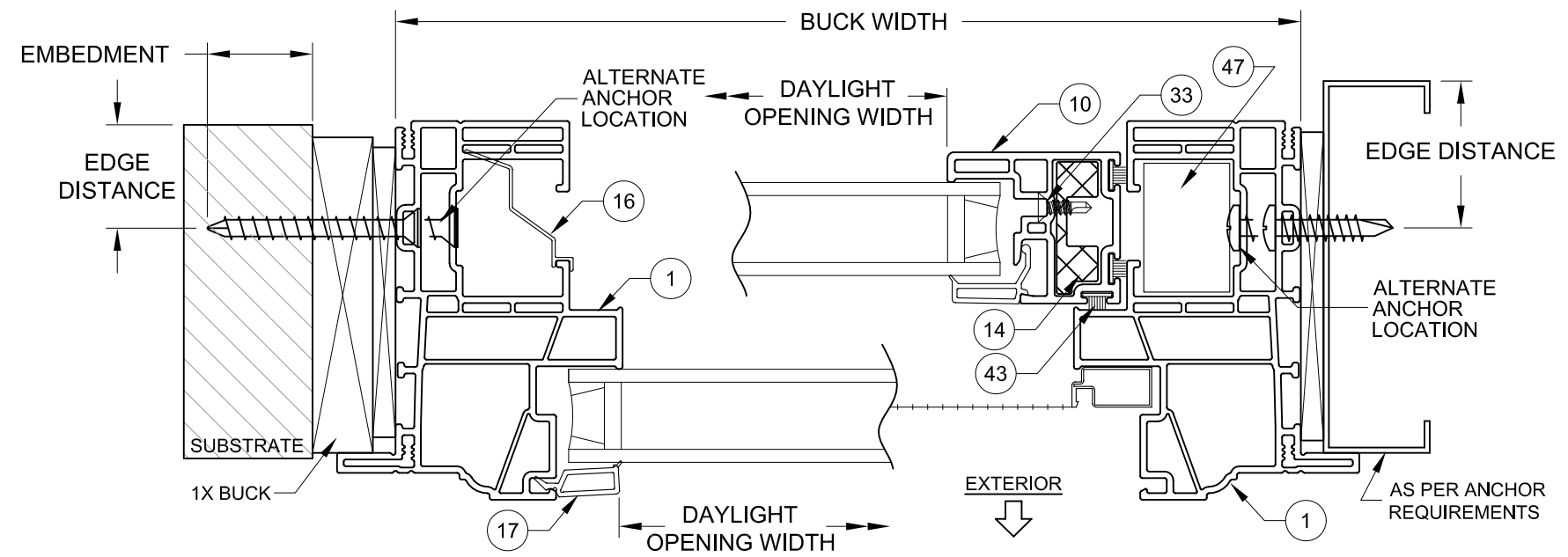
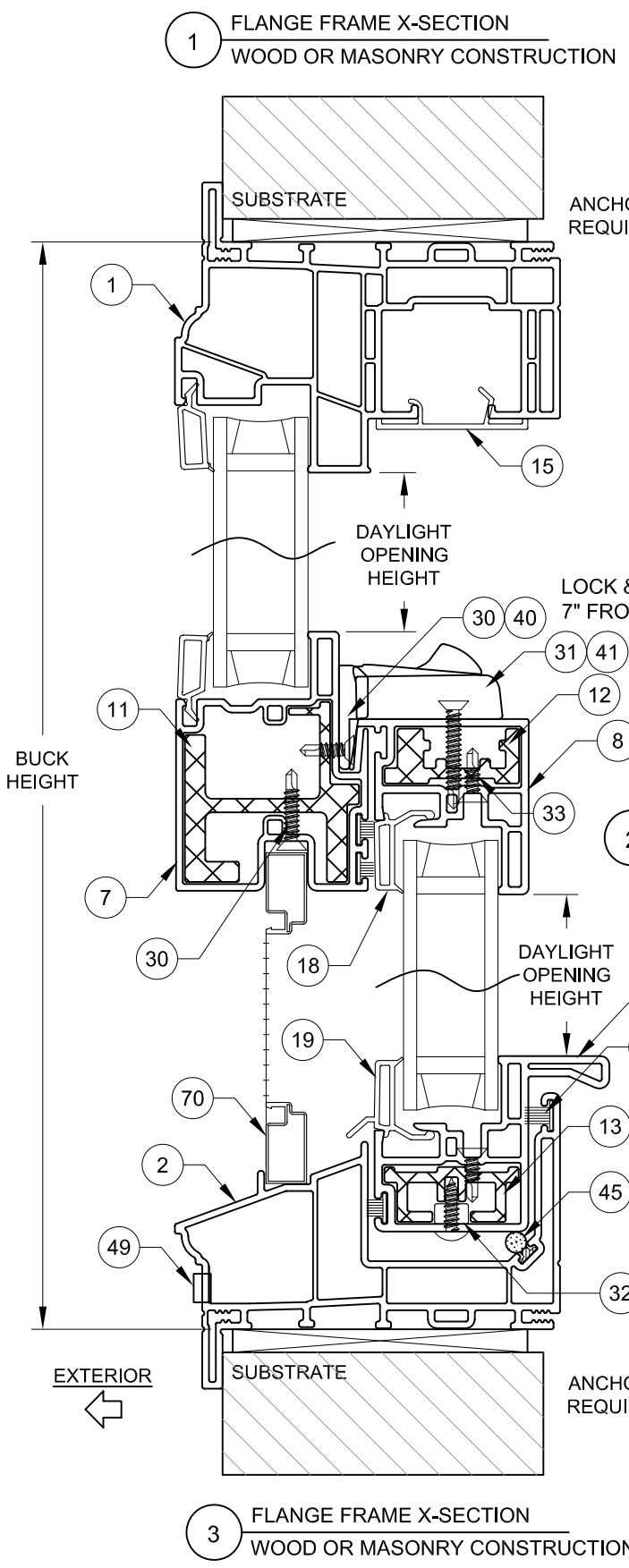

TABLE 2: INSTALLATION ANCHORS

Anchor	Substrate	Minimum Edge Distance	Minimum Embedment
#10 or #12 Steel or 410 SS Screw	Southern Pine (SG = .55)	1/2"	1-3/8"
	Aluminum, 6063-T5 min.	5/16"	0.050"
	Steel Stud, Gr. 33 min.	5/16"	0.045" (20 Ga)
	A36 Steel	5/16"	0.050"
3/16" Steel Ultracon+	Concrete (min. 2.9 ksi)	1"	1-3/4"
	UngROUTED CMU, (ASTM C-90)	1-1/16"	1-1/4"
	Southern Pine (SG = .55)	1"	1-3/8"
1/4" Steel Ultracon+	Concrete (min. 3.0 ksi)	1"	1-3/8"
	UngROUTED CMU, (ASTM C-90)	1"	1-1/4"
	Southern Pine (SG = .55)	1"	1-3/8"

- 1) ANCHOR MUST EXTEND A MINIMUM OF 3 THREADS BEYOND ANY METAL SUBSTRATE.
- 2) "UNGROUTED CMU" VALUES MAY BE USED FOR GROUDED CMU APPLICATIONS.
- 3) ALL ANCHOR HEAD TYPES ARE APPLICABLE.

INSTALLATION NOTES:

- 1) SEE SHEET 1 FOR ANCHOR SPACING REQUIREMENTS.
- 2) ANY INSTALLATION OPTION SHOWN (2X BUCK OR WOOD FRAMING, 1X BUCK, DIRECT TO MASONRY, STEEL STUD) MAY BE USED ON ANY SIDE OF THE WINDOW.
- 3) USE ONLY SUBSTRATE APPROPRIATE ANCHORS LISTED IN ANCHOR TABLE 2. FOLLOW EMBEDMENT AND EDGE DISTANCE LIMITS. MAX. SHIM THICKNESS TO BE 1/4".



A. LYNN MILLER, P.E., P.E.# 106954

REGISTRATION #F-23136
 PREPARED BY: A. LYNN MILLER, P.E.
 1070 TECHNOLOGY DR
 N. VENICE, FL 34275
 (941)-480-1600

COPYRIGHT © 2023
 NEWSOUTH WINDOW SOLUTIONS
 LIMITED LICENSE TO MAKE
 COPIES FOR PERMITTING

BY: 9400 SERIES SINGLE HUNG, NI
 LY
 REVISION: MINOR EDITORIAL UPDATES
 DATE: 2/24
 # 1
 DATE: 02/24/2023
 SCALE: NTS
 BY: LOGAN YODER
 DRAWING #: SH9400-TDI-NI
 SHEET: 3 OF 6

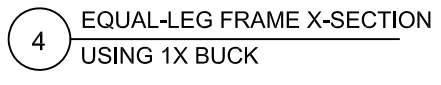
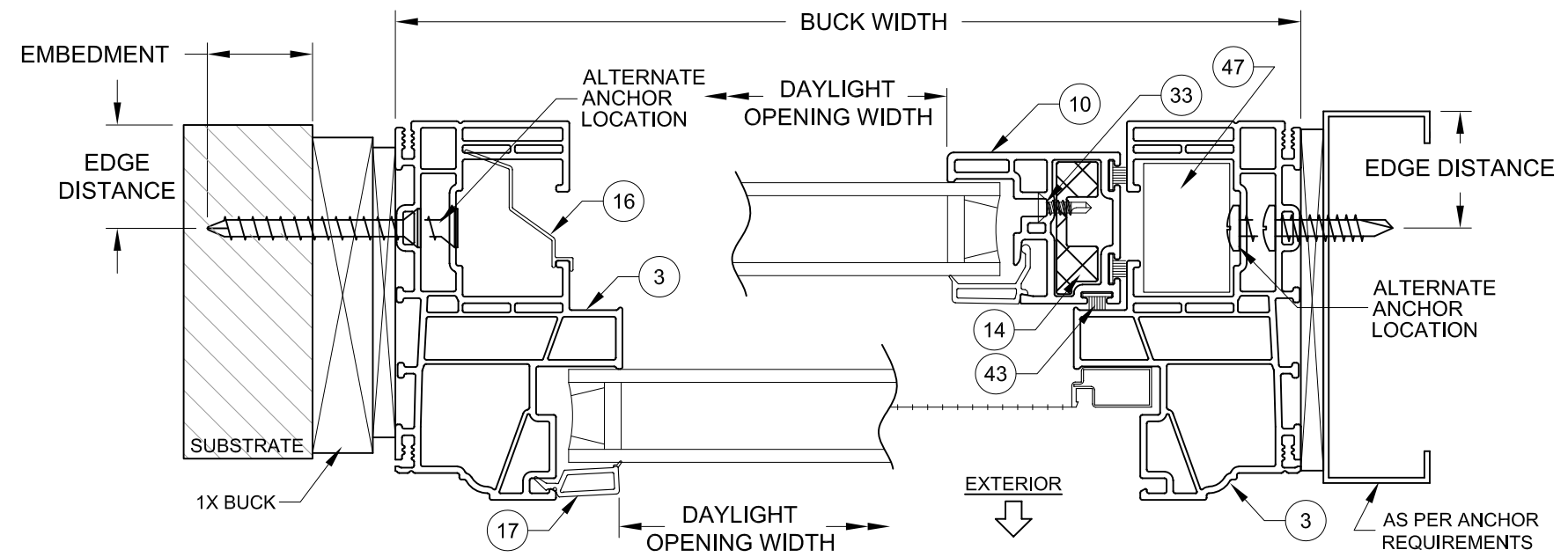
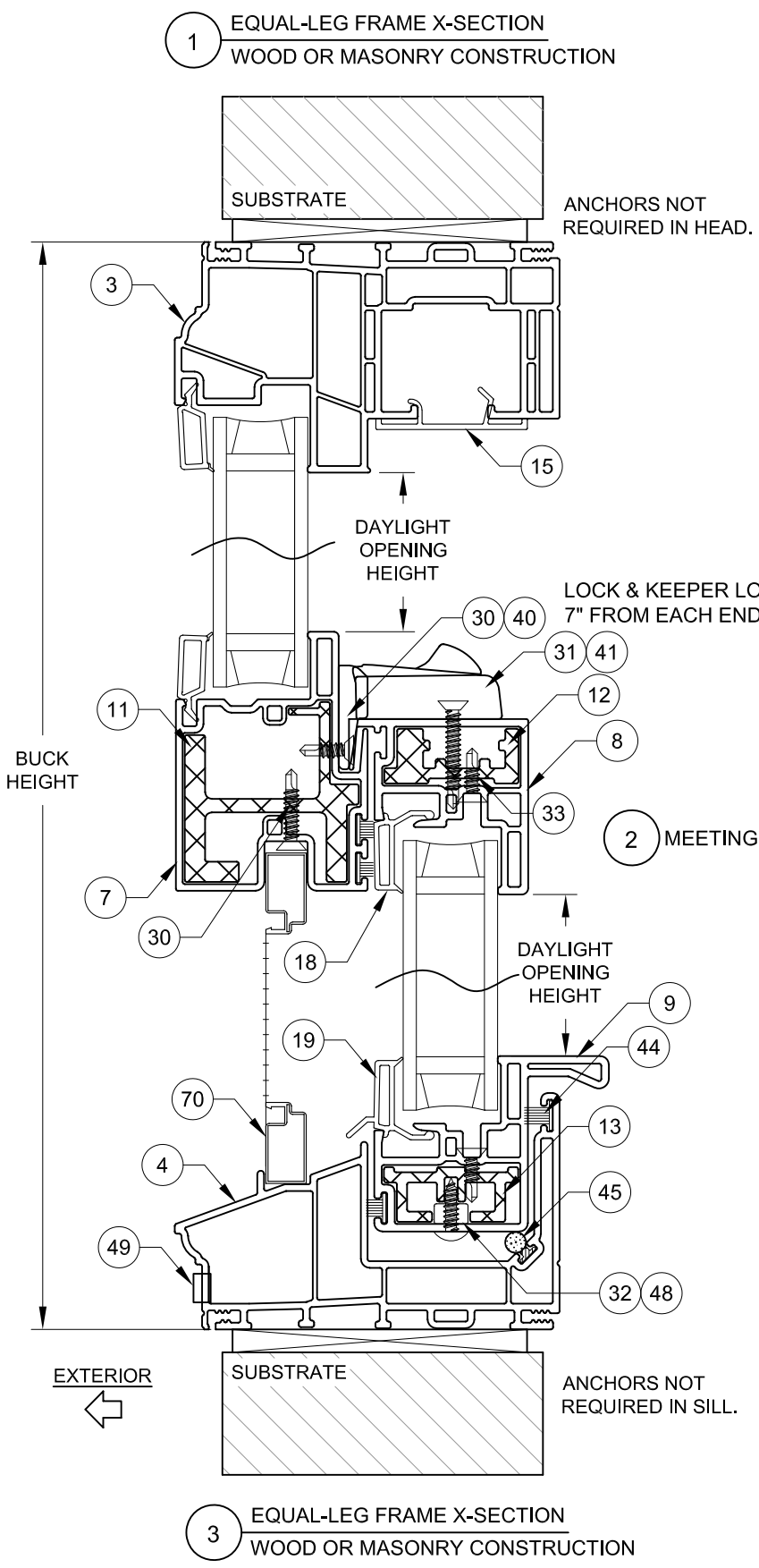

TABLE 3: INSTALLATION ANCHORS

Anchor	Substrate	Minimum Edge Distance	Minimum Embedment
#10 or #12 Steel or 410 SS Screw	Southern Pine (SG = .55)	1/2"	1-3/8"
	Aluminum, 6063-T5 min.	5/16"	0.050"
	Steel Stud, Gr. 33 min.	5/16"	0.045" (20 Ga)
	A36 Steel	5/16"	0.050"
3/16" Steel Ultracon+	Concrete (min. 2.9 ksi)	1"	1-3/4"
	UngROUTED CMU, (ASTM C-90)	1-1/16"	1-1/4"
	Southern Pine (SG = .55)	1"	1-3/8"
1/4" Steel Ultracon+	Concrete (min. 3.0 ksi)	1"	1-3/8"
	UngROUTED CMU, (ASTM C-90)	1"	1-1/4"
	Southern Pine (SG = .55)	1"	1-3/8"

- 1) ANCHOR MUST EXTEND A MINIMUM OF 3 THREADS BEYOND ANY METAL SUBSTRATE.
- 2) "UNGROUTED CMU" VALUES MAY BE USED FOR GROUDED CMU APPLICATIONS.
- 3) ALL ANCHOR HEAD TYPES ARE APPLICABLE.

INSTALLATION NOTES:

- 1) SEE SHEET 1 FOR ANCHOR SPACING REQUIREMENTS.
- 2) ANY INSTALLATION OPTION SHOWN (2X BUCK OR WOOD FRAMING, 1X BUCK, DIRECT TO MASONRY, STEEL STUD) MAY BE USED ON ANY SIDE OF THE WINDOW.
- 3) USE ONLY SUBSTRATE APPROPRIATE ANCHORS LISTED IN ANCHOR TABLE 3. FOLLOW EMBEDMENT AND EDGE DISTANCE LIMITS. MAX. SHIM THICKNESS TO BE 1/4".





A. LYNN MILLER, P.E., P.E.# 106954

REGISTRATION #F-23136
 PREPARED BY: A. LYNN MILLER, P.E.
 1070 TECHNOLOGY DR
 N. VENICE, FL 34275
 (941)-480-1600

COPYRIGHT © 2023
 NEWSOUTH WINDOW SOLUTIONS
 LIMITED LICENSE TO MAKE
 COPIES FOR PERMITTING

9400 SERIES SINGLE HUNG, NI
 FIN INSTALLATION SECTION VIEWS
 NEWSOUTH WINDOW SOLUTIONS
 10741 CROSSROADS COMMERCE BLVD.
 TAMPA, FL 33610

BY:	LY		
REVISION:	MINOR EDITORIAL UPDATES		
DATE:	2/24		
#:	1		
DATE:	02/24/2023		
SCALE:	NTS		
BY:	LOGAN YODER		
DRAWING #:	SH9400-TDI-NI		
SHEET:	4 OF 6		

1 FIN FRAME X-SECTION USING NAILS

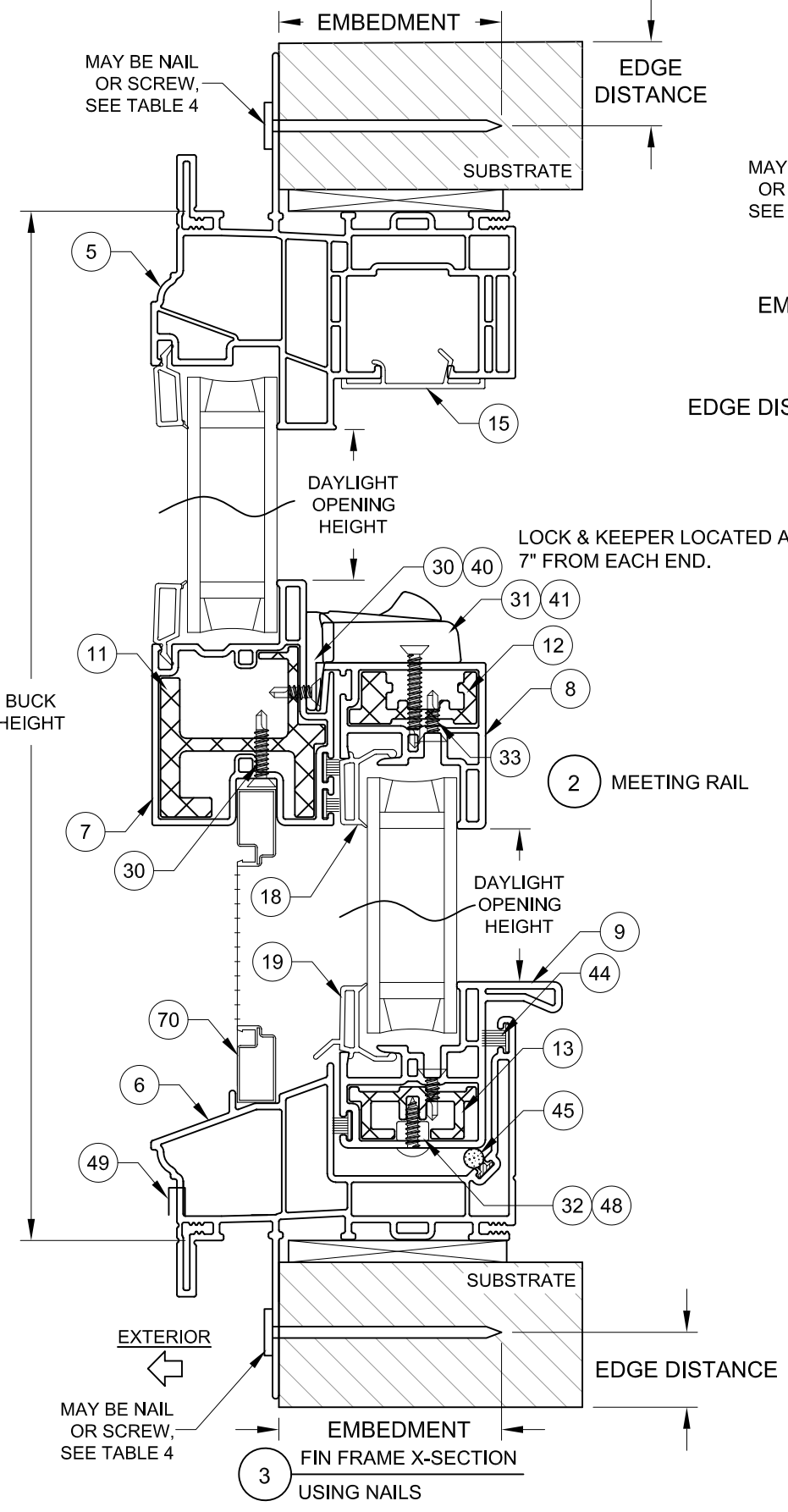

3 FIN FRAME X-SECTION USING NAILS

4 FIN FRAME X-SECTION USING SCREWS

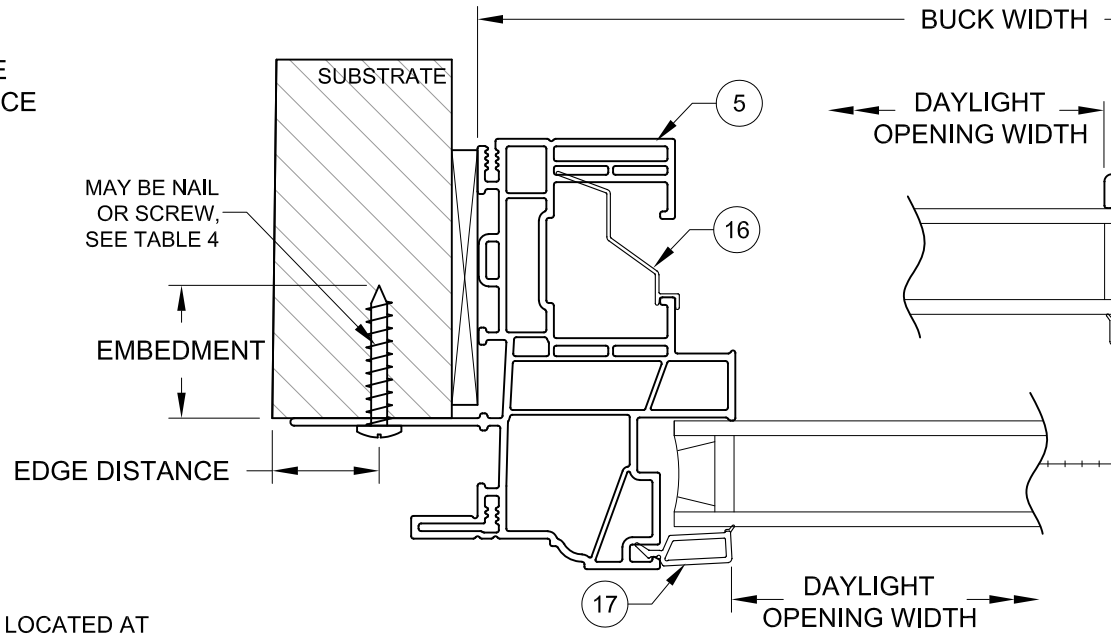

5 FIN FRAME X-SECTION STEEL STUD CONSTRUCTION

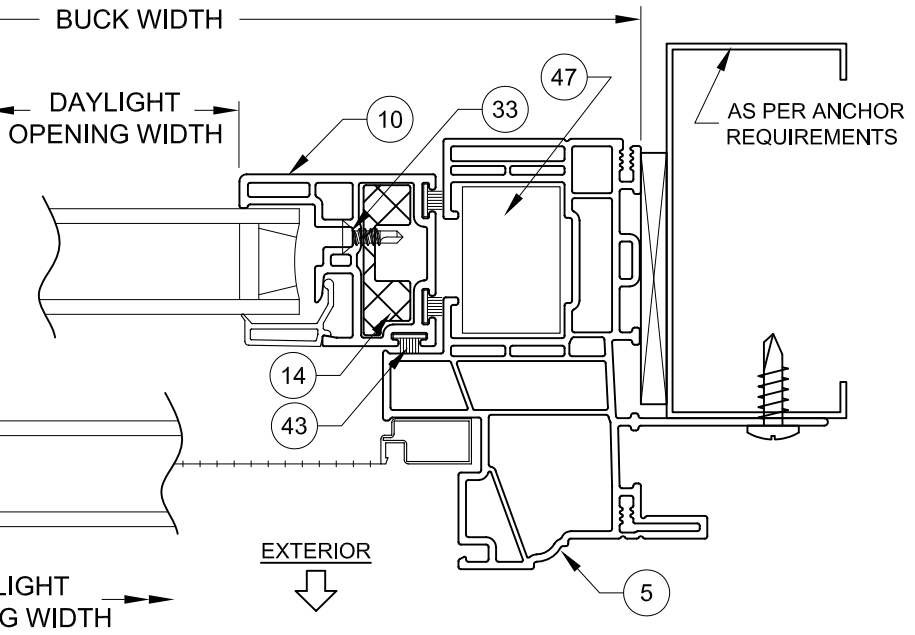

TABLE 4: INSTALLATION ANCHORS

Anchor	Substrate	Min. Edge Distance	Min. Embedment
2-1/2" x .113" Box Nail	P.T. Southern Pine (SG = .55)	5/16"	2-7/16"
2-1/2" x .131" Common Nail	P.T. Southern Pine (SG = .55)	3/8"	2-7/16"
2-1/2" x .145" Roofing Nail	P.T. Southern Pine (SG = .55)	3/8"	2-7/16"
#10 Steel SMS	P.T. Southern Pine (SG = .55)	1/2"	1-3/8"
	Aluminum, 6063-T5 min.	3/8"	1/8"
	Steel Stud, Gr. 33 min.	3/8"	0.036
	A36 Steel	3/8"	1/8"

1) ANCHOR MUST EXTEND A MINIMUM OF 3 THREADS BEYOND ANY METAL SUBSTRATE.
 2) ALL ANCHOR HEAD TYPES ARE APPLICABLE.

INSTALLATION NOTES:

- 1) SEE SHEET 1 FOR ANCHOR SPACING REQUIREMENTS.
- 2) FLANGE AND/OR FIN MAY BE REMOVED TO CREATE OTHER FRAME TYPES.
- 3) USE ONLY SUBSTRATE APPROPRIATE ANCHORS LISTED IN ANCHOR TABLE 4. FOLLOW EMBEDMENT AND EDGE DISTANCE LIMITS.
- 4) MAX SHIM THICKNESS TO BE 1/4". MAX SHIM SPACING TO BE 18".

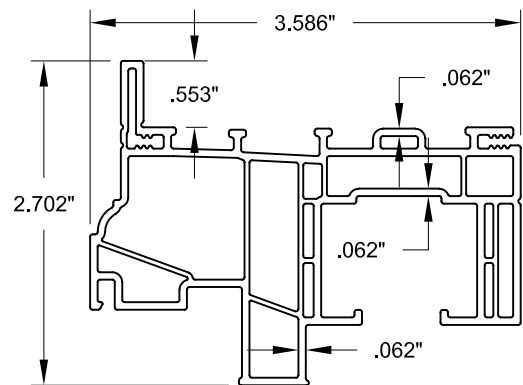

1 HEAD & JAMB, W/FLANGE

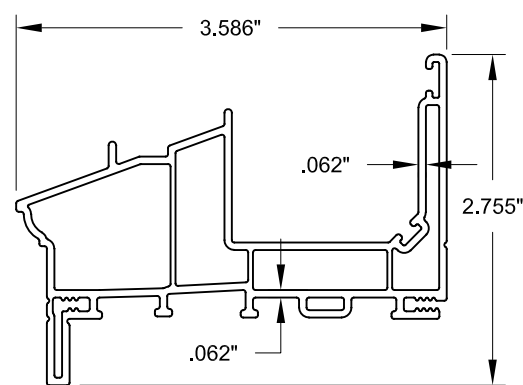

2 SILL, W/FLANGE

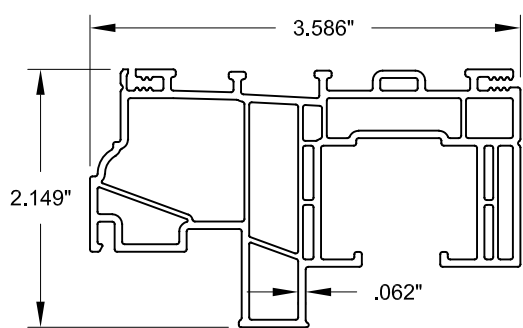

3 HEAD & JAMB, EQUAL LEG

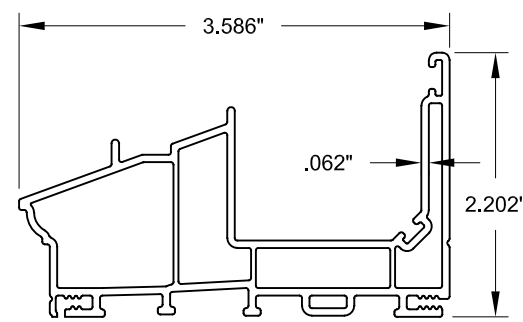

4 SILL, EQUAL LEG

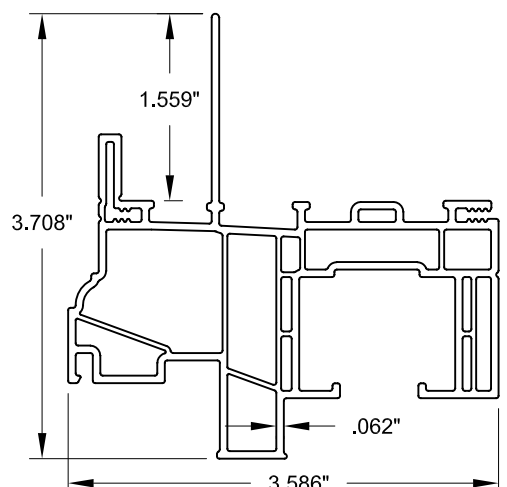

5 HEAD & JAMB, W/NAILING FIN

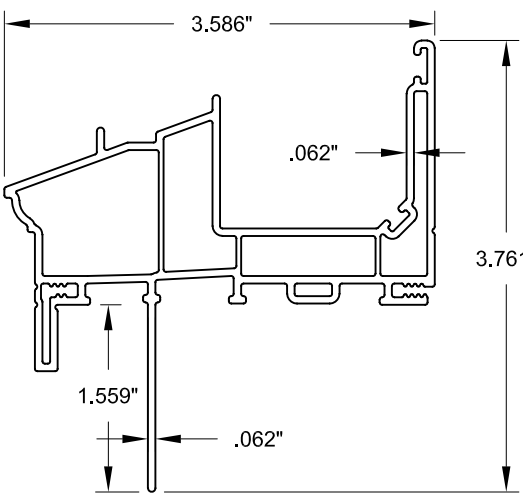

6 SILL, W/NAILING FIN

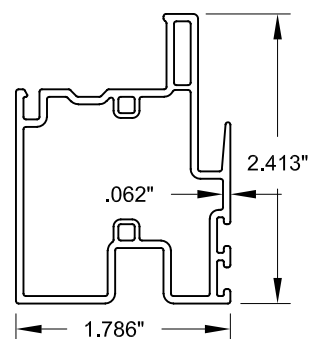

7 MEETING RAIL

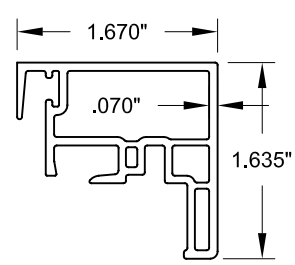

8 LOCK RAIL

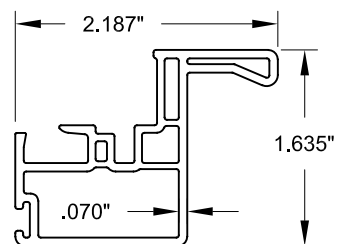

9 LIFT RAIL

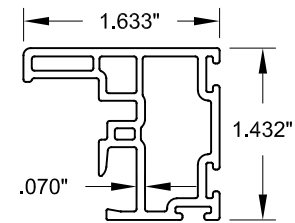

10 SASH STILE

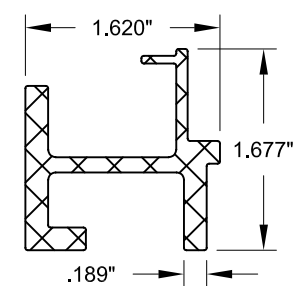

11 REINFORCEMENT (MEETING RAIL)

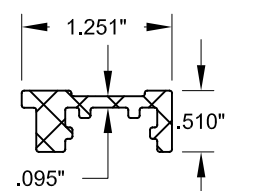

12 REINFORCEMENT (LOCK RAIL)

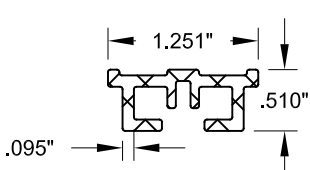

13 REINFORCEMENT (BOTTOM RAIL)

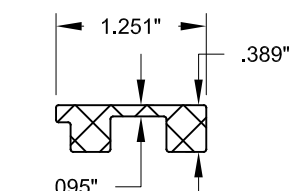

14 REINFORCEMENT (SASH STILE)

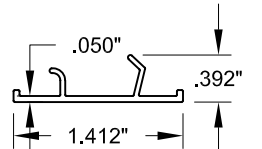

15 SASH STOP

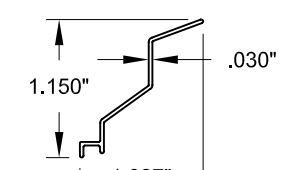

16 BALANCE COVER

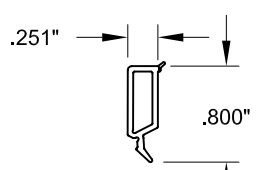

17 FIXED LITE GLAZING BEAD

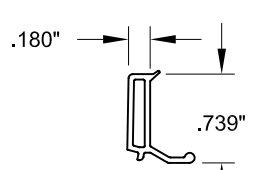

18 SASH GLAZING BEAD

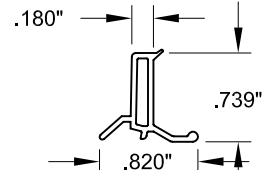

19 SASH GLAZING BEAD WITH DRIP EDGE (OPTIONAL)

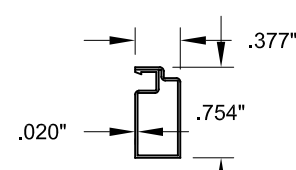

20 SCREEN FRAME

TABLE 5:

#	Part #	Description	Material
1	9465	Head & Jamb, w/Flange	PVC
2	9469	Sill, w/Flange	PVC
3	9465	Head & Jamb, Equal Leg	PVC
4	9469	Sill, Equal Leg	PVC
5	9455	Head & Jamb, w/Nailing Fin	PVC
6	9459	Sill, w/Nailing Fin	PVC
7	9477	Meeting Rail	PVC
8	9485	Lock Rail	PVC
9	9476	Sash Lift Rail	PVC
10	9438	Sash Stiles	PVC
11	6166	Reinf. - Meeting Rail	6063-T5
12	6165	Reinf. - Lock Rail	6063-T5
13	6163	Reinf. - Lift Rail	6063-T5
14	6164	Reinf. - Stiles	6063-T5
15	9473	Sash Stop	PVC
16	9468	Balancer Cover	PVC
17	9736	Fixed Lite Glazing Bead	PVC
18	9425	Sash Glazing Bead	PVC
19	9467	Sash Glazing Bead w/Drip Edge	PVC
30	1012	Screw, #6 x 3/4" PFH	Steel
31	1007	Screw, #6 x 1-1/8" PFH	Steel
32	1015	Screw, #8 x 1/2" PTRUSS	Steel
33	1003	Screw, #6 x 1/2" PFH	Steel
40	8096	Keeper	Zinc
41		Lock	
42	8121	MR Backing Plate	SS
43	4006	WSTP, .270" x .220" Polyfin	
44	4008	WSTP, .270" x .320" Polyfin	
45	4012	WSTP, Bulb Vinyl, .187" x .300"	Steel
46	8205/8206	Tilt Latch, L&R	Zinc
47		Balance	
48	8148	Pivot Bar	SS
49	8223	Weep Cover	Nylon
60		RGS 7700, Pecora 895, SikaFlex 552, Dow 791, 983 or 995	
61		Insulated Glass Spacer	
62	7061	Setting Block, 1/8" x 7/8" x 2"	EPDM
70	6244	Screen Frame	Aluminum

THE APPROVED, RIGID PVC EXTERIOR EXTRUSIONS ARE TO BE PRODUCED BY EXTRUDERS' LICENSEES UNDER "AAMA CERTIFICATION PROGRAMS FOR RIGID PVC EXTRUSIONS".



A. LYNN MILLER, P.E., P.E.# 106954

REGISTRATION #F-23136
 PREPARED BY: A. LYNN MILLER, P.E.
 1070 TECHNOLOGY DR
 N. VENICE, FL 34275
 (941)-480-1600

COPYRIGHT © 2023
 NEWSOUTH WINDOW SOLUTIONS
 LIMITED LICENSE TO MAKE
 COPIES FOR PERMITTING

BY: 9400 SERIES SINGLE HUNG, NI
 LY
 EXTRUSIONS & BOM
 NEWSOUTH WINDOW SOLUTIONS
 10741 CROSSROADS COMMERCE BLVD.
 TAMPA, FL 33610

REVISION:	DATE:	#:
MINOR EDITORIAL UPDATES	2/24	1

DATE: 02/24/2023
 SCALE: NTS
 BY: LOGAN YODER
 DRAWING #: SH9400-TDI-NI
 SHEET: 5 OF 6

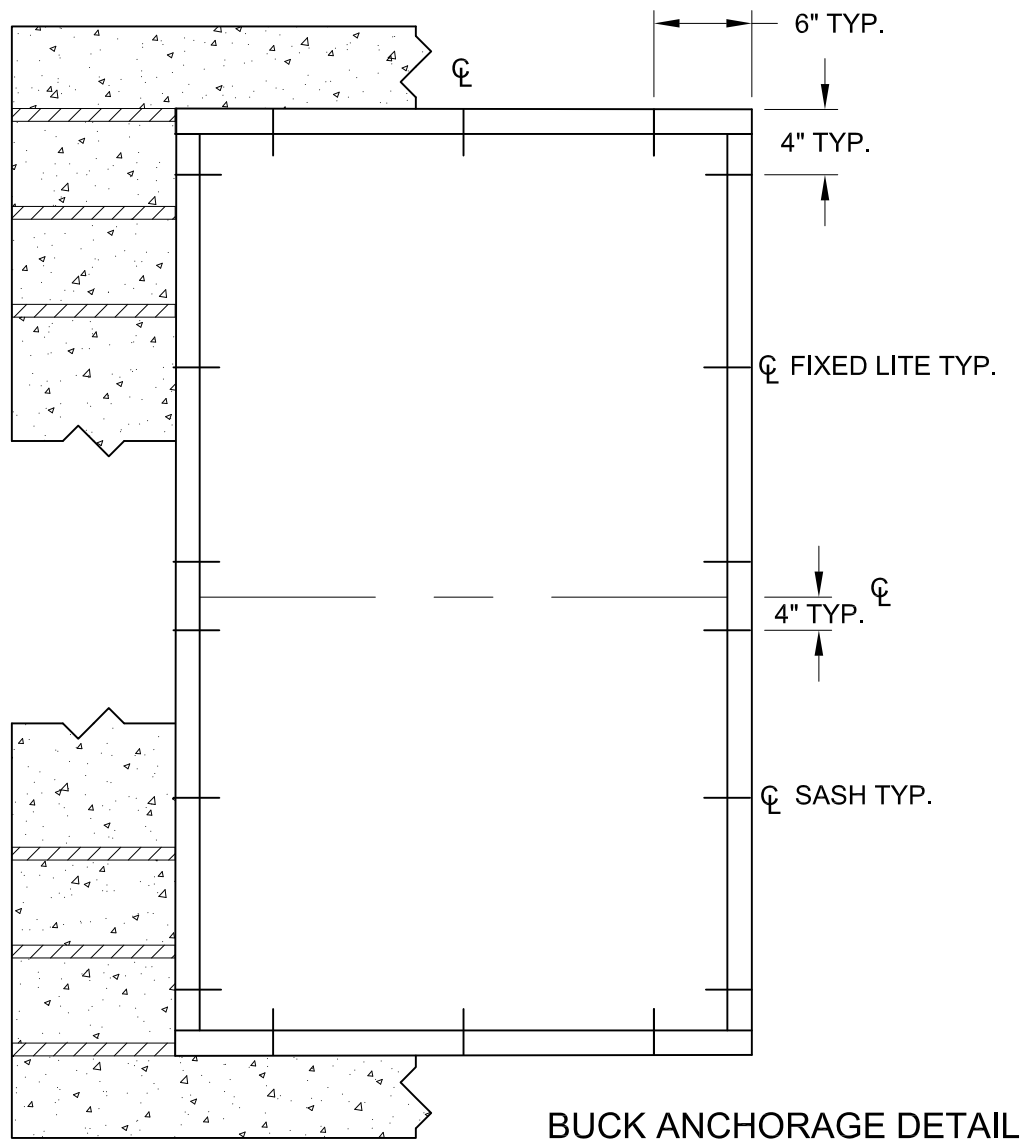

BUCK ANCHORAGE DETAIL

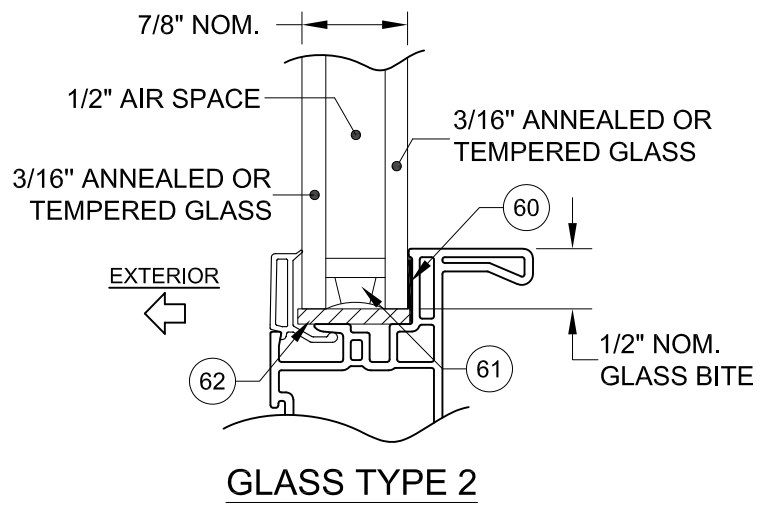
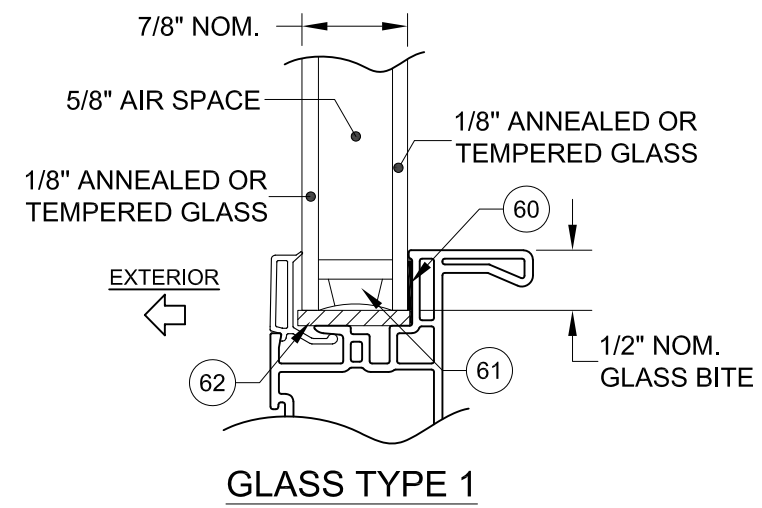

TABLE 6:

Anchor	Substrate	Minimum Edge Distance	Minimum Embedment
1/4" Steel Ultracon+	Concrete (min. 3.0 ksi)	1"	1-3/8"
	UngROUTED CMU, (ASTM C-90)	1"	1-1/4"

1) "UNGROUTED CMU" VALUES MAY BE USED FOR GROUDED CMU APPLICATIONS.

2) ALL ANCHOR HEAD TYPES ARE APPLICABLE.



A. Lynn Miller 2/28/23

A. LYNN MILLER, P.E., P.E.# 106954

REGISTRATION #F-23136

COPYRIGHT © 2023
NEWSOUTH WINDOW SOLUTIONS
LIMITED LICENSE TO MAKE
COPIES FOR PERMITTING

PREPARED BY: A. LYNN MILLER, P.E.
1070 TECHNOLOGY DR
N. VENICE, FL 34275
(941)-480-1600

BY: 9400 SERIES SINGLE HUNG, NI
BUCK INSTALLATION DETAILS
NEWSOUTH WINDOW SOLUTIONS
10741 CROSSROADS COMMERCE BLVD.
TAMPA, FL 33610

REVISION:	BY: LY
DATE: 2/24	REVISION: MINOR EDITORIAL UPDATES
#: 1	

DATE: 02/24/2023

SCALE: NTS

BY: LOGAN YODER

DRAWING #: SH9400-TDI-NI

SHEET: 6 OF 6