

GENERAL NOTES:

1. ALL FASTENERS SHALL BE IN ACCORDANCE WITH THESE DRAWINGS. SPECIFIED ANCHOR EMBED TO BASE MATERIAL SHALL BE BEYOND WALL FINISH OR STUCCO.
2. OPENINGS, BUCKING & BUCKING FASTENERS MUST BE PROPERLY DESIGNED & INSTALLED TO TRANSFER WIND LOADS TO THE STRUCTURE.
3. THESE NON-IMPACT RATED PRODUCT INSTALLATIONS ARE IN ACCORDANCE WITH AND MEET THE REQUIREMENTS OF THE 2018 INTERNATIONAL BUILDING CODE (IBC).
4. ALL ANCHORS SECURING PRODUCT FRAME TO PRESSURE TREATED BUCKS OR WOOD FRAMING SHALL BE CAPABLE OF RESISTING CORROSION CAUSED BY THE PRESSURE TREATING CHEMICALS IN THE WOOD.
5. TO THE BEST OF OUR KNOWLEDGE, THE PRODUCT SHOWN HEREIN IS CERTIFIED & QUALITY ASSURED BY A NATIONALLY ACCREDITED CERTIFICATION/QA ENTITY & SHALL BE LABELED IN ACCORDANCE WITH CERTIFICATION/QA ENTITIES SPECIFICATIONS.
6. PRODUCT ASSEMBLY IS NOT PART OF THIS DRAWING AND SHALL BE IN ACCORDANCE WITH THE MANUFACTURER'S QUALITY ASSURANCE SPECIFICATIONS & TESTING REPORTS.
7. CERTIFICATION OF THESE PRODUCT INSTALLATIONS SHALL BE CONSIDERED VOID IF ANY OF THE FOLLOWING APPLY: 1) THEY ARE INSTALLED WITHOUT A BUILDING PERMIT FROM THE APPLICABLE LOCAL BUILDING DEPARTMENT. 2) IF THEY ARE INSTALLED BY ANYONE OTHER THAN A LICENSED CONTRACTOR EXPERIENCED WITH WINDOW/DOOR INSTALLATIONS. 3) IF CHANGES HAVE OCCURRED TO THE PRODUCT'S CERTIFICATION ENTITY'S CERTIFICATE THAT CAUSE THESE INSTALLATIONS TO BE INCORRECT OR INCONSISTENT WITH WHAT HAS BEEN TESTED.
8. THE LEAST DESIGN PRESSURE SPECIFIED EITHER IN THIS DRAWING OR IN THE PRODUCT'S CERTIFICATION SHALL CONTROL FOR THE INSTALLED PRODUCT.
9. THESE DRAWINGS CERTIFY THE PRODUCT INSTALLATION ONLY. WATER PROOFING OF THE INSTALLED PRODUCT IS NOT PART OF THIS INSTALLATION CERTIFICATION. THAT RESPONSIBILITY SHALL BE THAT OF THE MANUFACTURER &/OR INSTALLER.

MAX. FRAME WIDTH (IN.)	MAX. FRAME HEIGHT (IN.)	ALLOWABLE PRESSURE	
		POSITIVE (PSF)	NEGATIVE (PSF)
36	73	60	60
48	73	50	50
52 1/8	50	60	60
54	63	50	50
54	90	45	45

CONDITIONS SHOWN IN THESE DRAWINGS ARE GOVERNED BY INSTALLATION REQUIREMENTS ONLY. THE GOVERNING CONDITIONS ON ANY SPECIFIC PRODUCT SHALL BE THE LESSER OF THOSE SPECIFIED IN THE PRODUCTS' APPROVAL OR THAT SHOWN IN THESE DRAWINGS.

ALTERNATE ANCHOR/SUBSTRATE EVALUATION NOTE:
 ALL ALTERNATE ANCHORS IN THEIR SPECIFIED SUBSTRATES HAVE BEEN ANALYZED IN ACCORDANCE WITH THEIR APPLICABLE STANDARD(S) AND ARE FOUND TO BE EQUIVALENT TO OR STRONGER THAN THE ANCHOR(S) USED IN TESTING WITH THIS PRODUCT.

INSTALLATION EVALUATION IS BASED ON APPLICABLE ANCHOR STANDARDS AND/OR INFORMATION & RESULTS FROM APPLICABLE TEST REPORTS. THE BUILDING CODE VERSION CONSIDERED WITH THE EVALUATION WAS THAT IN FORCE AT THE TIME OF THE EVALUATION. IN THE EVENT OF CODE VERSION CHANGES/UPDATES OR IN THE EVENT THAT NEW OR ADDITIONAL TESTING IS COMPLETED ON THE REFERENCED PRODUCT, PRIOR TO STATING CODE COMPLIANCE, THE MANUFACTURER SHALL CONFIRM WITH THE INSTALLATION EVALUATION ENGINEER OF RECORD THAT THE INSTALLATIONS SPECIFIED HERE-IN ARE CURRENT WITH THE THEN CURRENT TESTING, CODE AND APPLICABLE STANDARDS.

FRAME ANCHOR REQUIREMENTS TABLE

OPENING TYPE (SUBSTRATE)	FRAME TO OPENING FASTENER TYPE	MINIMUM EMBED	MINIMUM EDGE DIST.
(1) FRAME SCREWS			
MIN. 2X4 WOOD FRAME OR BUCK (MIN. GR. 3 & G=0.55)	NO. 10 SMS OR WOOD SCREW	1 1/4"	3/4"
MIN. 18 GA. 33 KSI METAL STUD	NO. 10 GR. 5 SELF TAP/DRILL SCREW	FULL	1/2"
MIN. 1/8" THK A36 STEEL	NO. 10 GR. 5 SELF TAP/DRILL SCREW	FULL	1/2"
MIN. 1/8" THK 6063-T5 ALUM.	NO. 10 GR. 5 SELF TAP/DRILL SCREW	FULL	1/2"
C-90 CMU/2500 PSI CONCRETE	(2) 1/4" CONCRETE SCREW	1 1/4"	2"
(1) FRAME SCREWS SHALL BE PAN HEAD OR HEX HEAD SCREW			
(2) CONCRETE SCREWS SHALL BE ELCO ULTRACONS (C.S.), ELCO CRETE-FLEX (S.S.), ITW RAMSET/RED HEAD TAPCONS (C.S. OR S.S.) OR HILTI KWIK-CON II (C.S. OR S.S.).			

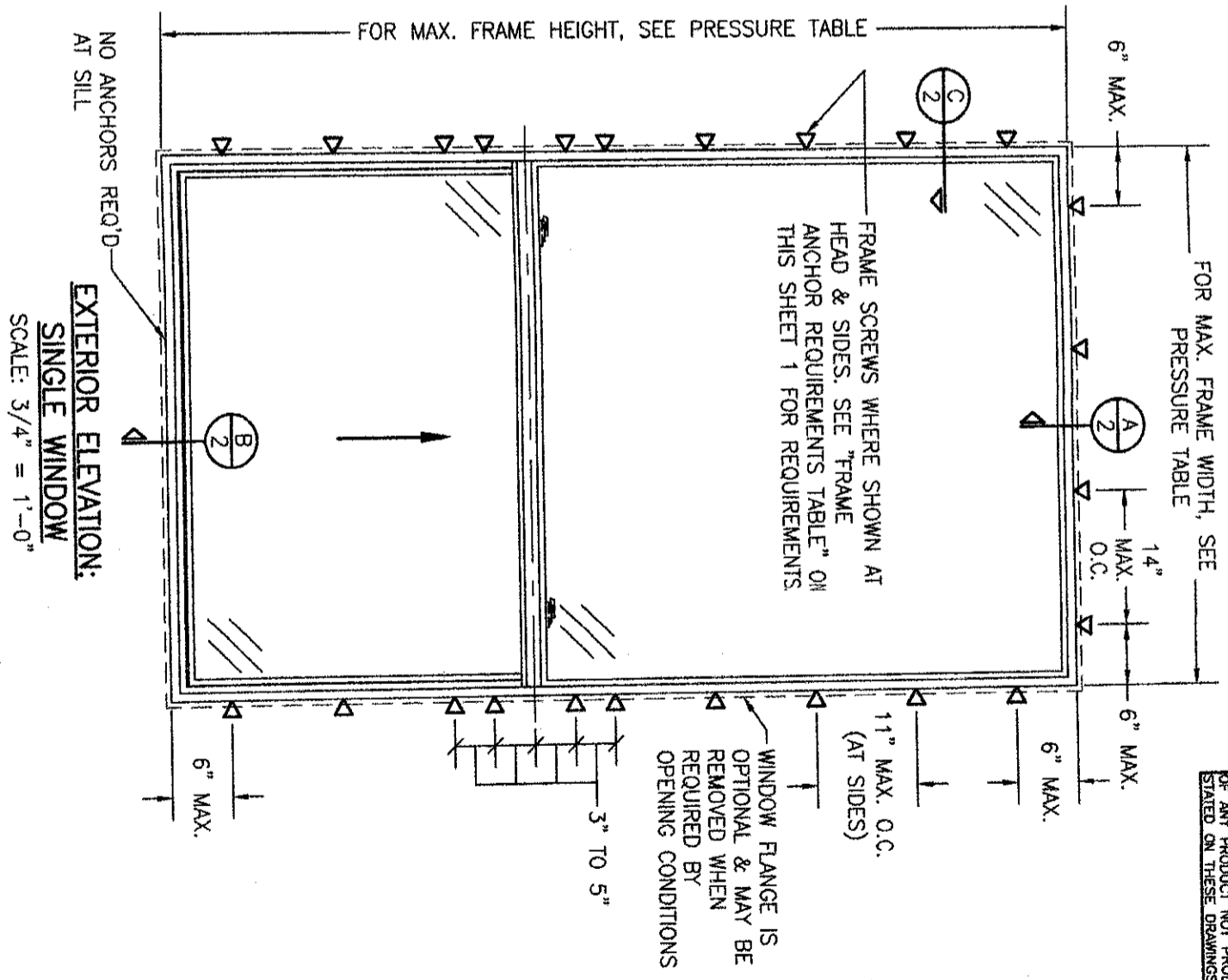

THESE DRAWINGS ARE APPLICABLE ONLY TO THE PRODUCT SPECIFIED. THEY MAY NOT BE USED FOR THE ASSEMBLY AND/OR INSTALLATION OF ANY OTHER PRODUCT NOR MAY THEY BE USED FOR RATIONAL AND/OR LOCAL APPROVAL OF ANY PRODUCT NOT PRODUCED BY THE MANUFACTURER STATED ON THESE DRAWINGS.

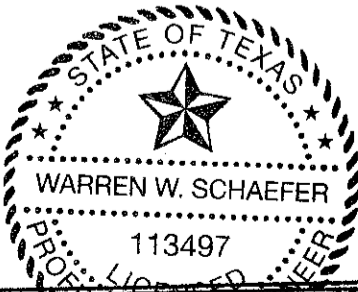

OCT 06 2021

DRAWING TITLE
 THERMASTAR 10 SERIES SINGLE HUNG FLANGE NON-IMPACT WINDOW

CONSULTANTS
 W. W. SCHAEFER ENGINEERING & CONSULTING, P.A. (REG. NO. F-14980)
 7480 150TH COURT NORTH
 PALM BEACH GARDENS, FL 33418
 PHONE: 561-744-3424

JOB INFORMATION:
 PELLA CORPORATION
 2000 PROLINE PLACE
 GETTYSBURG, PA 17325
 717-334-0099

NO.	REVISION DESCRIPTION	BY	DATE
1			10/05/21

CHECKED BY: W.W.S.
 DATE: 10/05/21
 DRAWN BY: W.W.S.
 DATE: 10/05/21

DRAWING NO. 1414T
 SHEET NO. 1 OF 2
 WARREN W. SCHAEFER, P.E.
 P.E. NO. 113497

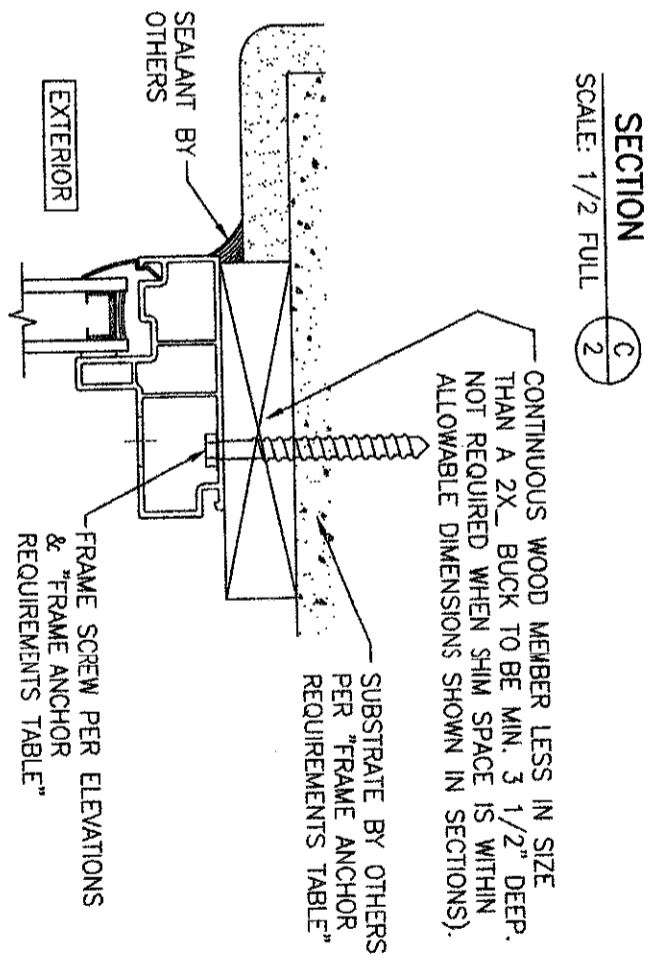
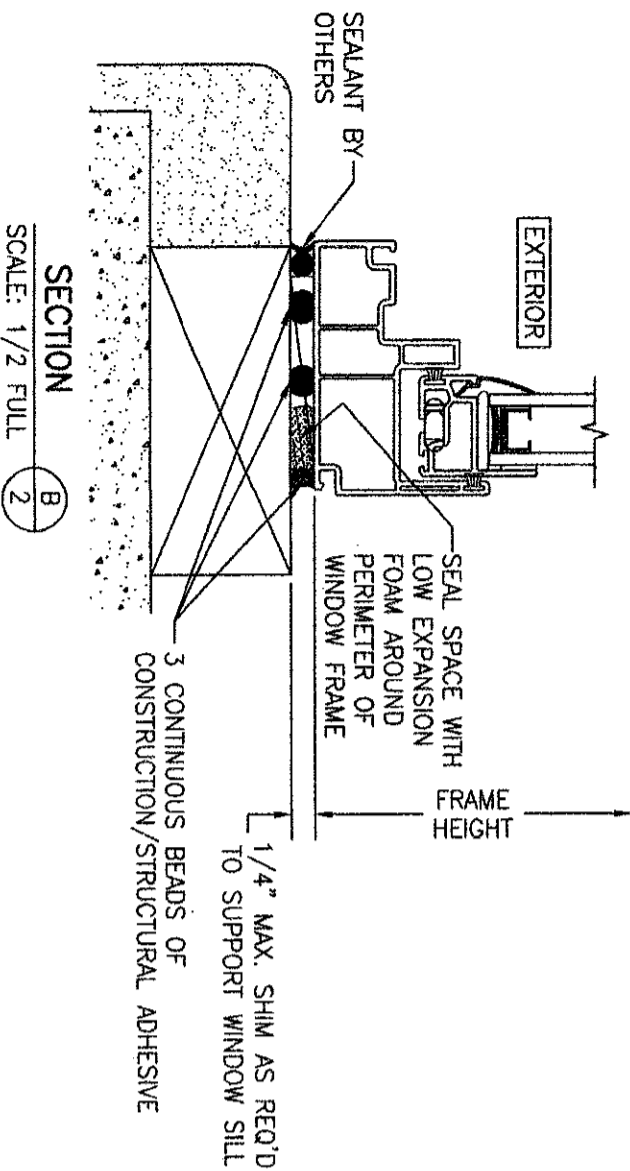
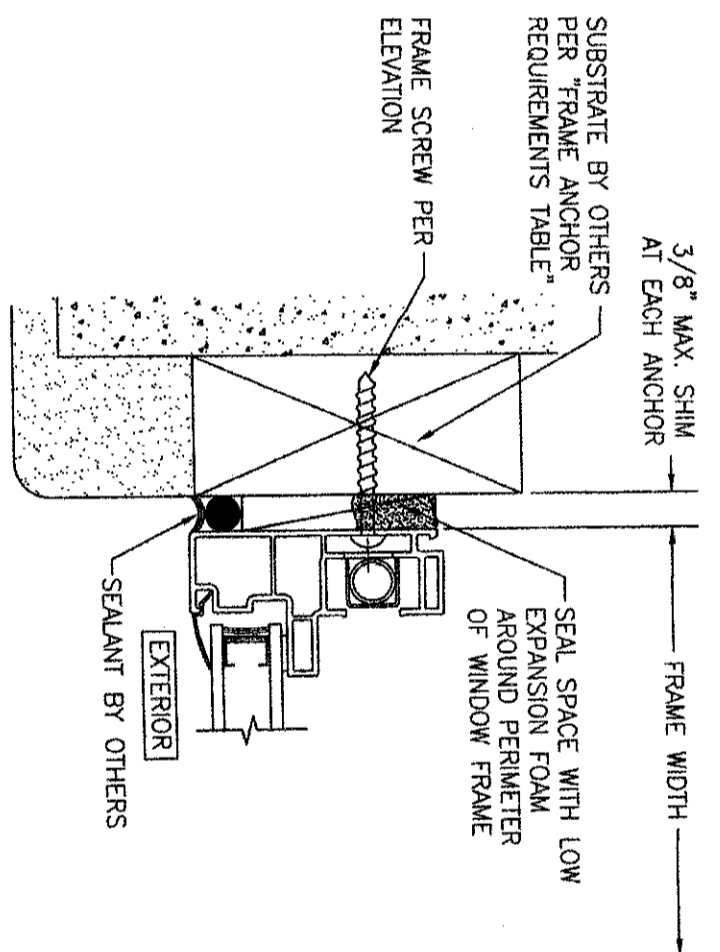
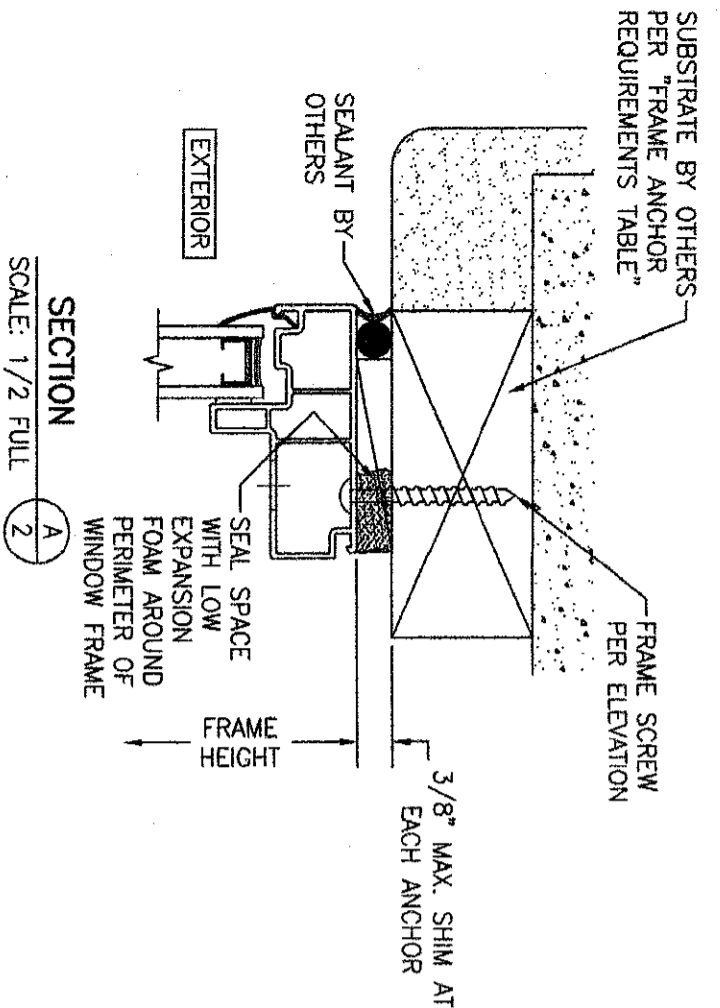

OPTIONAL DIRECT MOUNT DETAIL TO SUBSTRATE WITH SPACER
 (HEAD SECTION SHOWN, SIDES ARE INSTALLED THE SAME)
 (SILL DOES NOT APPLY)
 (FOR DETAIL NOT SHOWN, SEE OTHER SECTIONS)

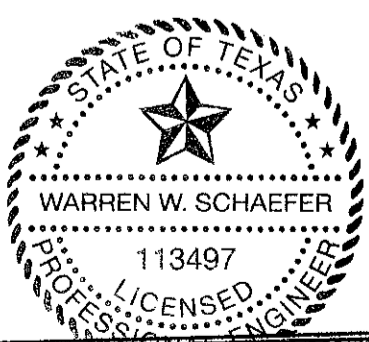

OCT 06 2021

WARREN W. SCHAEFER, P.E.
 P.E. NO. 113497

DRAWING TITLE
THERMASTAR 10 SERIES SINGLE HUNG FLANGE NON-IMPACT WINDOW

CONSULTANTS
W. W. SCHAEFER ENGINEERING & CONSULTING, P.A. (REG. NO. F-14980)
 7480 150TH COURT NORTH
 PALM BEACH GARDENS, FL 33418
 PHONE: 561-744-3424

JOB INFORMATION:
PELLA CORPORATION
 2000 PROLINE PLACE
 GETTYSBURG, PA 17325
 717-334-0099

NO.	REVISION DESCRIPTION	BY	DATE

DRAWING NO. 1414T
 SHEET NO. 2 OF 2