

Product Evaluation

RV95 | 0923

Engineering Services Program

The following product has been evaluated for compliance with the wind loads specified in the International Residential Code (IRC) and the International Building Code (IBC).

This product evaluation is not an endorsement of this product or a recommendation that this product be used. The Texas Department of Insurance has not authorized the use of any information contained in the product evaluation for advertising, or other commercial or promotional purpose.

This product evaluation is intended for use by those individuals who are following the design wind load criteria in Chapter 3 of the IRC and Section 1609 of the IBC. The design loads determined for the building or structure shall not exceed the design load rating specified for the products shown in the limitations section of this product evaluation. This product evaluation does not relieve a Texas licensed engineer of his responsibilities as outlined in the Texas Insurance Code, the Texas Administrative Code, and the Texas Engineering Practice Act.

For more information, contact TDI Engineering Services Program at (800) 248-6032.

Evaluation ID: RV-95

Effective Date: September 1, 2023

Re-evaluation Date: September 2027

Product Name: Ridgeline Low Profile Steel Ridge Ventilators

Manufacturer: Metallic Products
7777 Hollister Street
Houston, TX
(800) 356-7746

General Description:

Ridgeline Low Profile Steel Ridge Ventilator: A ventilator for metal roofs. The vent is constructed of 24-gauge steel. The vent consists of a steel skirt, Cor-A-Vent ventilation core, and a steel floating ridge cap. The throat width varies with roof slope. The ventilator is factory assembled and ready for installation. Vent dimensions are shown in Figure 1. The vent is 10' long. The ventilators can be butted together to form a continuous run.

Limitations:

Design Wind Pressure:

Ridgeline Low Profile Steel Ridge Ventilator: -190 psf

Roof Slope:

Vents may be installed on roofs with a minimum slope of 1:12 and a maximum slope of 12:12.

Installation:

General: The vent is installed in accordance with the manufacturer's installation instructions and this evaluation report.

Option 1:

Roof Framing: The roof framing must be minimum Southern Yellow Pine dimension lumber.

Fasteners: The ridge vent is secured to the roof framing with minimum No. 12 x 1-1/2" long self-tapping hex head screws with neoprene washers. The fasteners must be long enough to penetrate a minimum of 1-1/4" into the wood framing. Fasteners must be installed through the skirt on each side of the ridge vent. The fasteners are located 6" from each end and approximately 12" on center. Fasteners must be long enough to penetrate a minimum of 1-1/4" into the wood.

Option 2:

Roof Framing: The roof framing must be minimum 24-gauge steel.

Fasteners: The ridge vent is secured to the roof framing with minimum No. 12 x 1" long self-tapping hex head screws with neoprene washers. Fasteners must be installed through the skirt on each side of the ridge vent. The fasteners are located 6" from each end and approximately 12" on center. Fasteners must be long enough to penetrate a minimum of 3 pitches of thread below the steel member

Note: Keep the manufacturer's installation instructions available on the job site during the installation. Use corrosion resistant fasteners as specified in the IRC and the IBC.

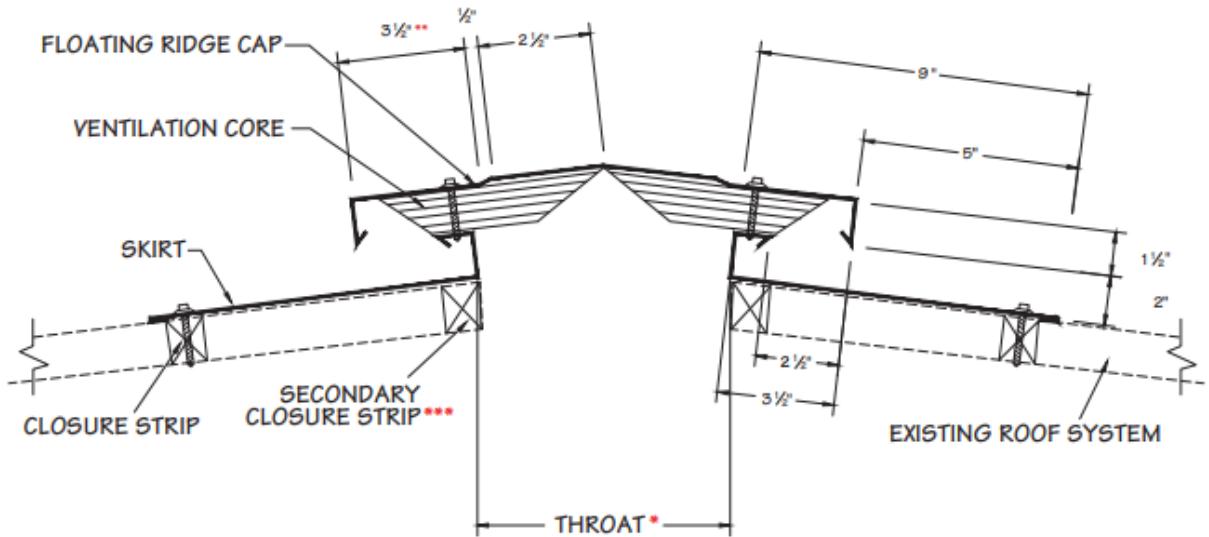

THROAT SIZE
(Determined by Roof Pitch)

PITCH	THROAT SIZE
1:12	4-1/8"
2:12	4-1/8"
3:12	4-1/8"
4:12	4-1/8"
5:12	3-1/2"
6:12	2-7/8"
7:12	4-5/8"
8:12	4-1/8"
9:12	3-1/2"
10:12	3"
11:12	2-9/16"
12:12	2"

NOTE

Roof panel must extend to throat of vent for proper support and drainage. End caps and splice kits (if necessary) are shipped loose for field installation.

* Throat varies with roof slope. (See table)

** This dimension changes to 5" on roof slopes 7:12 – 12:12.

*** Secondary closure at ridge is recommended at each skirt splice in a continuous run.

Figure 1. Vent Specifications.