

Product Evaluation

RC87 | 0621

Engineering Services Program

The following product has been evaluated for compliance with the wind loads specified in the International Residential Code (IRC) and the International Building Code (IBC).

This product evaluation is not an endorsement of this product or a recommendation that this product be used. The Texas Department of Insurance has not authorized the use of any information contained in the product evaluation for advertising, or other commercial or promotional purpose.

This product evaluation is intended for use by those individuals who are following the design wind load criteria in Chapter 3 of the IRC and Section 1609 of the IBC. The design loads determined for the building or structure shall not exceed the design load rating specified for the products shown in the limitations section of this product evaluation. This product evaluation does not relieve a Texas licensed engineer of his responsibilities as outlined in the Texas Insurance Code, the Texas Administrative Code, and the Texas Engineering Practice Act.

For more information, contact TDI Engineering Services Program at (800) 248-6032.

Evaluation ID: RC-87

Effective Date: June 1, 2021

Re-evaluation Date: June 2025

Product Name: U, UPN, and PBU Steel Roof Panels Installed Over a Wood Structural Panel Deck

Manufacturer: Mueller, Inc.
Steel Building Systems and Components
1913 Hutchins Avenue
Ballinger, TX 76821
(800) 527-1087

General Description:

The U, UPN, and PBU roof panels are manufactured from 26-gauge coated steel conforming to ASTM A446, Grade E, with a minimum yield strength of 80,000 psi. The panels have either an AZ 55 hot-dip aluminum zinc alloy coating or a hot dip galvanized coating conforming to ASTM A525.

Limitations:

Design Wind Pressures: For installation to nominal 15/32" plywood decks, design wind pressure limitations are specified in Table 1. For installation to nominal 7/16" OSB decks, design wind pressure limitations are specified in Table 2.

Roof Deck Attachment: The roof deck must be secured to the roof framing to resist the required wind uplift design pressures.

Installation Over an Existing Roof Covering: Installation over an existing roof covering is limited to a maximum of one existing layer of composition shingles, wood shingles or shakes, built-up roofing, or roll roofing. The thickness of the existing roof deck must be as required for a new roof panel installation. Note: Inspection of the existing roof deck must be made before installing the roof panels. The condition of the existing roof deck must be acceptable to receive the roof panels before the roof panel installation can proceed.

Roof Slope: The roof panels must not be installed on roofs with a roof slope less than 1/2:12 if sealant is used on the panel side laps. If sealant is not used on the panel side laps, then the minimum roof slope is 3:12.

Installation:

Panels: The roof panels must be attached to the roof deck in accordance with the installation details and Tables 1-2. Refer to Figure 1 for illustrations of the screw patterns.

Table 1

Attachment of 26-gauge U, UPN, and PBU Roof Panel to nominal 15/32" plywood roof decking:

Design Pressure (psf)	Fastener Pattern	Fastener Spacing
-22.7	12" – 12" – 12"	36"
-59.3	12" – 12" – 12"	30"
-96.8	6" – 6" – 6" – 6" – 6"	24"
-169.3	6" – 6" – 6" – 6" – 6"	12"

Table 2

Attachment of 26-gauge U, UPN, and PBU Roof Panel to nominal 7/16" OSB roof decking:

Design Pressure (psf)	Fastener Pattern	Fastener Spacing
-22.7	12" – 12" – 12"	30"
-61.8	6" – 6" – 6" – 6" – 6"	30"

Underlayment: Titanium™-UDL synthetic roofing underlayment. The underlayment must be installed with a minimum 4" minimum side lap and a minimum 6" end lap. Stagger end laps at least 36". The underlayment must be applied with corrosion-resistant fasteners and 1" minimum diameter metal caps. Fasteners must be applied at 6" on center along the side/vertical laps and at 12" on center along the center of the roll in the field as marked.

Alternative Underlayment: A minimum of one layer of No. 30 (Type II) asphalt felt must be used. The underlayment used must comply with one or more of the following: ASTM D 226, ASTM D 4869, or ASTM D 1970. The felt must be installed with minimum 6" side laps and minimum 2" end laps. The underlayment must be applied with corrosion-resistant fasteners in accordance with manufacturer's installation instructions. Fasteners must be applied along the overlaps not farther apart than 36" on center.

Anchorage of UPN-Panels to Roof Decking: The panels must be fastened in accordance with Tables 1-2 with No. 12-11 x 1" Low Profile screws with a sealing washer, manufactured by Atlas. Refer to Figure 1 for an illustration of the fastening patterns. If the panels are laid directly over an existing roof covering, then No. 12-11 x 1-1/2" Low Profile screws with a sealing washer, manufactured by Atlas, are required. The fasteners must be long enough to penetrate completely through the wood structural panels with a minimum exposure of 1/4" below the underside of the wood structural panels. The panel laps must be secured together with 1/4"-14 x 7/8" Lap Tek SD screws with washers, manufactured by Atlas, spaced 20" on center.

Panel Ends and End Laps: Secure the panel ends and endlaps to the steel purlins as the manufacturer requires.

Panel Edges: Secure the panel edges to the steel purlins as the manufacturer requires.

Trims, Closures, and Accessories: Install components, such as the eave trim, rake trim, ridge trim, hip trim, and valley trim as the manufacturer requires.

Alternative Fasteners: Substitution of equivalent fasteners must meet the following requirements:

No. 12-11 Low Profile screws with a sealing washer, manufactured by Atlas
Ultimate withdrawal (pullout) \geq 435.6 lbs. in 1/2" plywood
Ultimate withdrawal (pullout) \geq 215.4 lbs. in 7/16" OSB

1/4"-14 x 7/8" Lap Tek SD screws with washers, manufactured by Atlas
Ultimate withdrawal (pullout) in 26 Ga steel \geq 204 lbs.
Ultimate pullover through 26 Ga steel \geq 526 lbs.

Note: Keep the manufacturer's installation instructions available on the job site during the installation. Use corrosion resistant fasteners as specified in the IRC and the IBC.

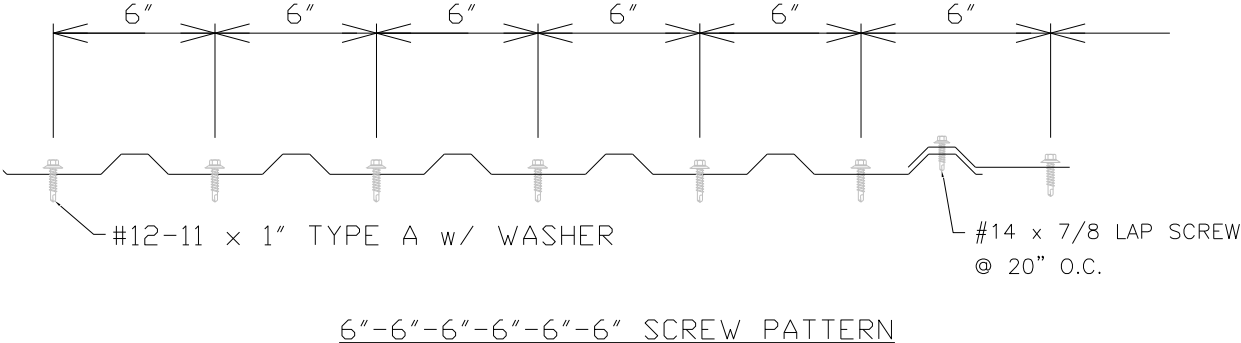
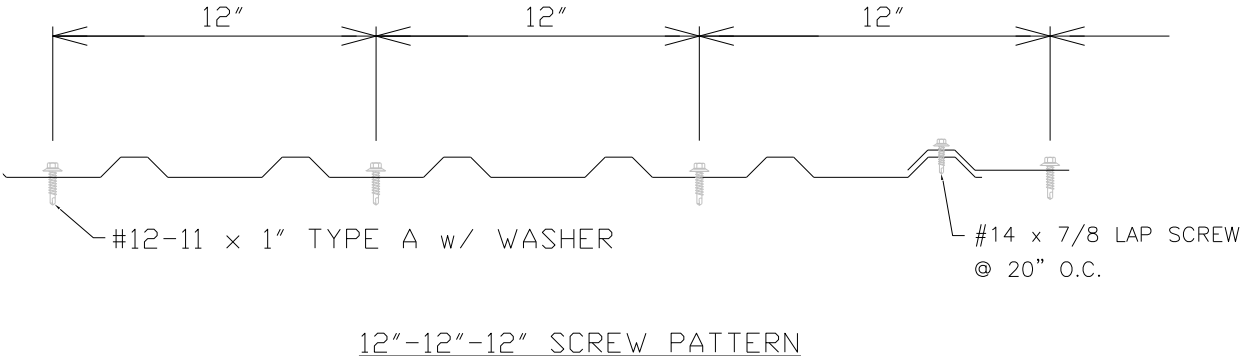

Figure 1: U, UPN, and PBU Panel Fastener Attachment Pattern