

Product Evaluation

RC168 | 0222

Engineering Services Program

The following product has been evaluated for compliance with the wind loads specified in the International Residential Code (IRC) and the International Building Code (IBC).

This product evaluation is not an endorsement of this product or a recommendation that this product be used. The Texas Department of Insurance has not authorized the use of any information contained in the product evaluation for advertising, or other commercial or promotional purpose.

This product evaluation is intended for use by those individuals who are following the design wind load criteria in Chapter 3 of the IRC and Section 1609 of the IBC. The design loads determined for the building or structure shall not exceed the design load rating specified for the products shown in the limitations section of this product evaluation. This product evaluation does not relieve a Texas licensed engineer of his responsibilities as outlined in the Texas Insurance Code, the Texas Administrative Code, and the Texas Engineering Practice Act.

For more information, contact TDI Engineering Services Program at (800) 248-6032.

Evaluation ID: RC-168

Effective Date: February 1, 2022

Re-evaluation Date: February 2026

Product Name: 26-Gauge PBR Steel Roof Panels Installed Over Steel Purlins

Manufacturer: Rigid Global Buildings
18933 Aldine Westfield
Houston, TX 77073
(281) 443-9065

General Description:

The PBR metal roofing panels are steel roofing panels. The steel roofing panels have 36" of coverage. The steel roofing panels have a 1-1/4" rib height. The steel roofing panels are manufactured from minimum 26-gauge steel that conform to ASTM A792 with a minimum yield strength of 80,000 psi.

Limitations:

Roof Framing: The steel roofing panels must be installed over minimum 16-gauge steel purlins.

New Roof Framing Attachment: The roof framing must meet or exceed the uplift requirements of the IRC or IBC and must be installed as required for resistance to wind loads.

Design Wind Pressures: The design pressure uplift load resistance must be as specified in Table 1.

Roof Slope: The steel roofing panels may be installed on roofs with a roof slope as low as 1/2:12 if lap sealant is applied. Lap sealant must be applied in accordance with the manufacturer's approved installation instructions. If lap sealant is not used, then the minimum roof slope must be 3:12.

Table 1

Attachment of minimum 26-gauge PBR steel roofing panels to steel purlins

Design Wind Pressure	Purlins	Attachment of Panel to Steel Purlins
-124.8 psf	Minimum 16-gauge; 2'-0" on center	Fasteners @ 12"-12"-12" 2'-0" on center
-111.0 psf	Minimum 16-gauge; 2'-6" on center	Fasteners @ 12"-12"-12" 2'-6" on center
-97.3 psf	Minimum 16-gauge; 3'-0" on center	Fasteners @ 12"-12"-12" 3'-0" on center
-83.6 psf	Minimum 16-gauge; 3'-6" on center	Fasteners @ 12"-12"-12" 3'-6" on center
-69.9 psf	Minimum 16-gauge; 4'-0" on center	Fasteners @ 12"-12"-12" 4'-0" on center
-56.2 psf	Minimum 16-gauge; 4'-6" on center	Fasteners @ 12"-12"-12" 4'-6" on center
-42.5 psf	Minimum 16-gauge; 5'-0" on center	Fasteners @ 12"-12"-12" 5'-0" on center

Installation Over an Existing Roof Covering: Not permitted.

Installation:

General: The steel roofing panels must be installed in accordance with the manufacturer's recommended installation instructions and this evaluation report.

Steel Purlins: The minimum thickness of the steel and the maximum spacing of the purlins must be as specified in Table 1.

Attachment of Steel Roofing Panels to the Steel Purlins: The steel roofing panels must be secured to the steel purlins with minimum No. 12-14 x 1-1/4" long HWH self-driller screws with washer. The fasteners must be long enough to ensure a minimum penetration of 3 pitches of thread below the purlins. The fasteners must be located at each steel purlin with the pattern as shown in Table 1. Refer to Figure 1 of this evaluation report for an illustration of the required fastener pattern.

Panel Side Laps: The panels are stitched together with minimum 1/4-14 x 7/8" Lap Tek screws. The fasteners must be spaced a maximum of 20" on center along the length of the side lap.

Panel Edges, Ends, and End Laps to Steel Purlins: The steel roofing panel edges, ends, and end laps must be secured to the steel purlins with minimum No. 12-14 x 1-1/4" long HWH self-driller screws with washer. The fasteners must be long enough to ensure a minimum penetration of 3

itches of thread below the purlins. The fasteners must be located along the steel purlin with a 5"-7"-5"-7"-5" pattern.

Trims, Closures, and Accessories: Components, such as the eave trim, rake trim, ridge trim, hip trim, and valley trim must be installed as required by the manufacturer.

Note: Keep the manufacturer’s installation instructions available on the job site during installation. Use corrosion resistant fasteners as specified in the IRC and the IBC.

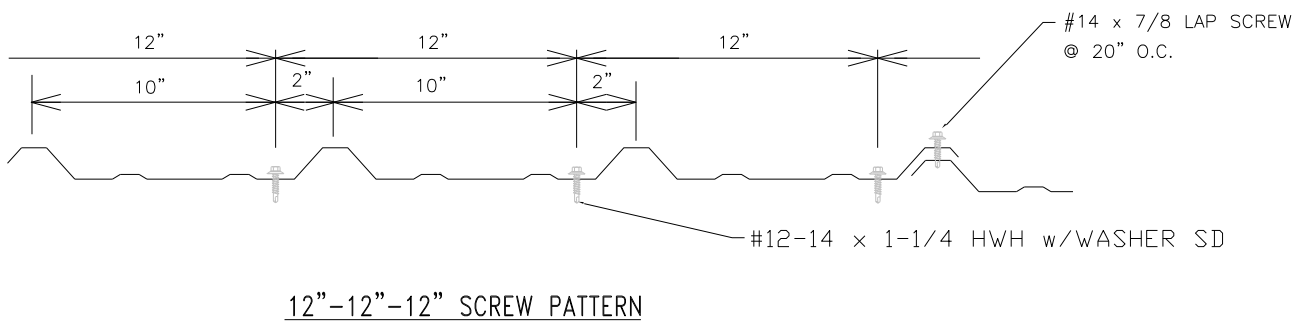

Figure 1. PBR Panel Fastener Pattern Detail (Minimum 26-Gauge Panel)