

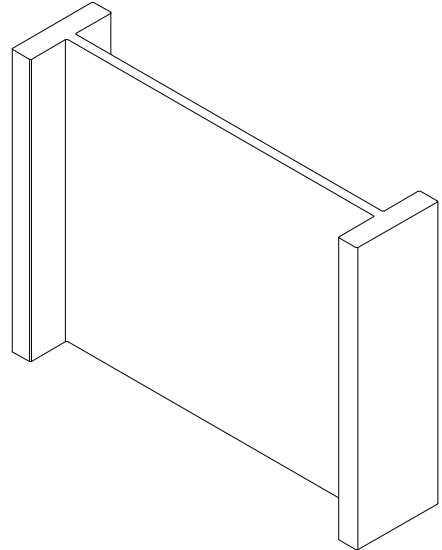

 1 COCHRANE AVE. PENNSBORO, WV 26415
 PH. 800-426-2249
**EXTRUDED NON-IMPACT VINYL MULLIONS
 WITH ALUMINUM REINFORCEMENT
 ALL NON-IMPACT WINDOW SERIES**

REVISIONS			
REV.	DESCRIPTION	DATE	BY
5	Updated DP ratings chart and added new mullion covers.	06/20/2012	T.D.D.
6	Updated O.C. spacing to 12" -FC 18-031.	08/08/2019	LMH
7	Update to include both horizontal & vertical views.	12/02/2019	LMH
.	.	.	.
.	.	.	.

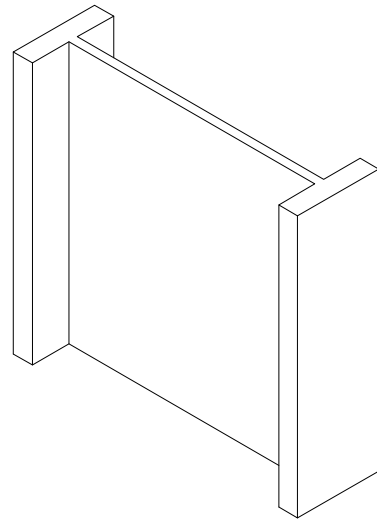

LARGE MULLION
 REINFORCEMENT CM0146
 ALUMINUM 6063-T6



LARGE MULLION
 REINFORCEMENT #16991
 ALUMINUM 6063-T6

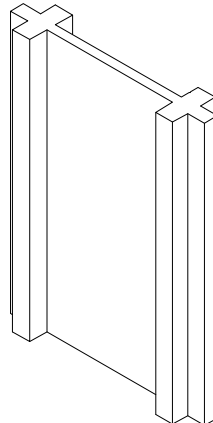

MEDIUM MULLION
 REINFORCEMENT #16990
 ALUMINUM 6063-T6

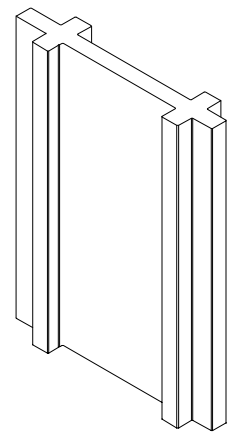

MEDIUM MULLION
 REINFORCEMENT #20634
 ALUMINUM 6063-T6



5000 FIN & J FRAME VINYL
 H-MULLION COVER #VPI-573
 EXTRUDED VINYL 0.071" MIN.



PROFINISH LARGE VINYL
 H-MULLION COVER #VPI-560
 EXTRUDED VINYL 0.079" MIN.

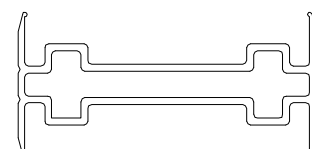

PROFINISH MEDIUM VINYL
 H-MULLION COVER #VPI-346A
 EXTRUDED VINYL 0.071" MIN.

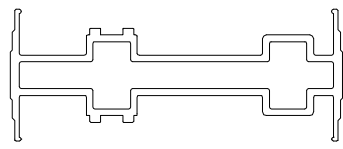

RETROFIT MEDIUM VINYL
 H-MULLION COVER #VPI-436
 EXTRUDED VINYL 0.070" MIN.

PRODUCT DESCRIPTION:

1. ALL MULLION REINFORCEMENTS ARE EXTRUDED ALUMINUM 6063-T6.
2. ALL MULLION COVERS ARE EXTRUDED VINYL. SEE ABOVE FOR INDIVIDUAL MULLION THICKNESS.

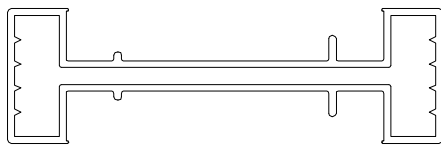

RETROFIT LARGE VINYL
 H-MULLION COVER #VPI-354
 EXTRUDED VINYL 0.071" MIN.

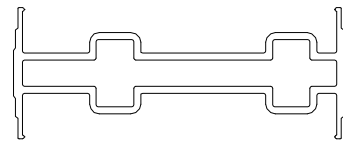

4000 SERIES MEDIUM VINYL
 H-MULLION COVER #MPO347
 EXTRUDED VINYL 0.070" MIN.

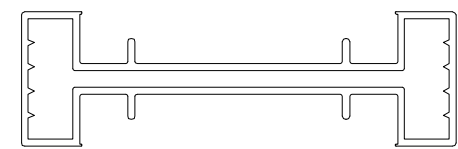

4000 SERIES LARGE VINYL
 H-MULLION COVER #VPI-354A
 EXTRUDED VINYL 0.071" MIN.

TABLE OF CONTENTS	
SHT	DESCRIPTION
1	INDIVIDUAL MULLION APPLICATIONS
2	DESIGN PRESSURES FOR REINFORCEMENT CM0146
3	DESIGN PRESSURES FOR REINFORCEMENT 16991
4	DESIGN PRESSURES FOR REINFORCEMENT 16990
5	DESIGN PRESSURES FOR REINFORCEMENT 20634
6	MULLION ATTACHMENT AND ANCHORING
7	MULLION CROSS SECTIONS-WOOD FRAME SUBSTRATE
8	MULLION CROSS SECTIONS-CONC. SUBSTRATE

GENERAL NOTES:

1. THE FOUR (4) MULLION PRODUCTS MEET THE 2006 INTERNATIONAL RESIDENTIAL CODE WITH TEXAS REVISIONS EFFECTIVE SEPT. 1, 2008, INCLUDING L/175 DEFLECTION LIMIT, LOAD TRANSFER, AND FIBERSTRESS ANALYSES IN THE DESIGN PRESSURES SHOWN IN THE TABLES IN THIS DRAWING. THE ANALYSES DID NOT ADDRESS AIR OR WATER INFILTRATION. OVERALL WINDOW ASSEMBLY ALLOWABLE DESIGN PRESSURES SHALL BE THE LOWER OF THE MULLION PER THIS APPROVAL OR THE SIMONTON WINDOWS PER SEPARATE PRODUCT APPROVAL.
2. PRODUCT ANCHORS SHALL BE AS LISTED AND SPACED AS SHOWN HEREIN.

	DRAWING NUMBER: REV. 7 C1 RMO015B
	DRAWN BY: RTW CHECKED BY: TDD DATE: 12/18/08
SCALE: 0.75:1 SHEET: 1 of 8 SERIES: ALL MULLED PRODUCTS-TDI TITLE: REINFORCED VINYL MULLIONS	APPROVED BY: CAP DATE: 01/20/12

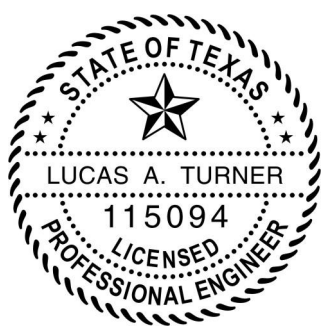

MULLION TRIBUTARY HEIGHT = SUM OF ZONE 2 WINDOW HEIGHTS

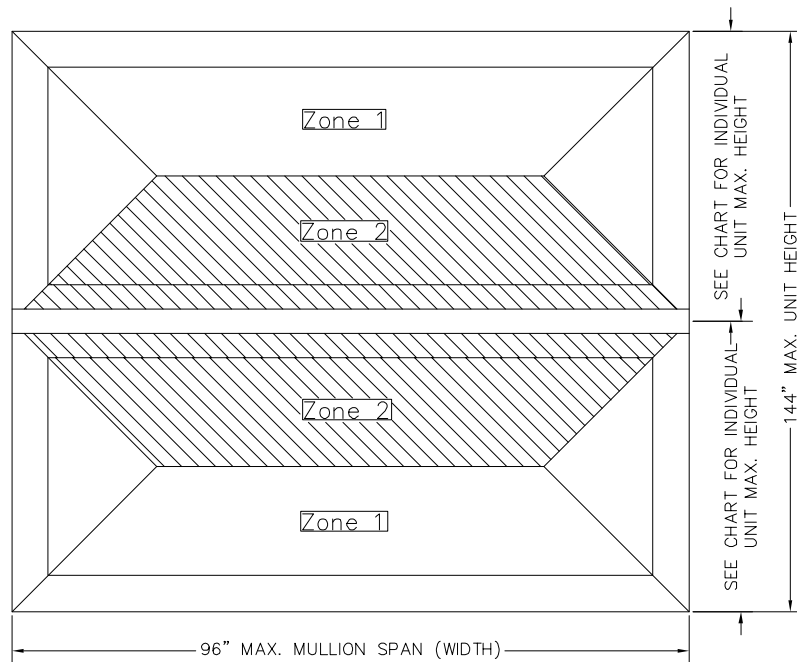

MULLION TRIBUTARY WIDTH = SUM OF ZONE 2 WINDOW WIDTHS

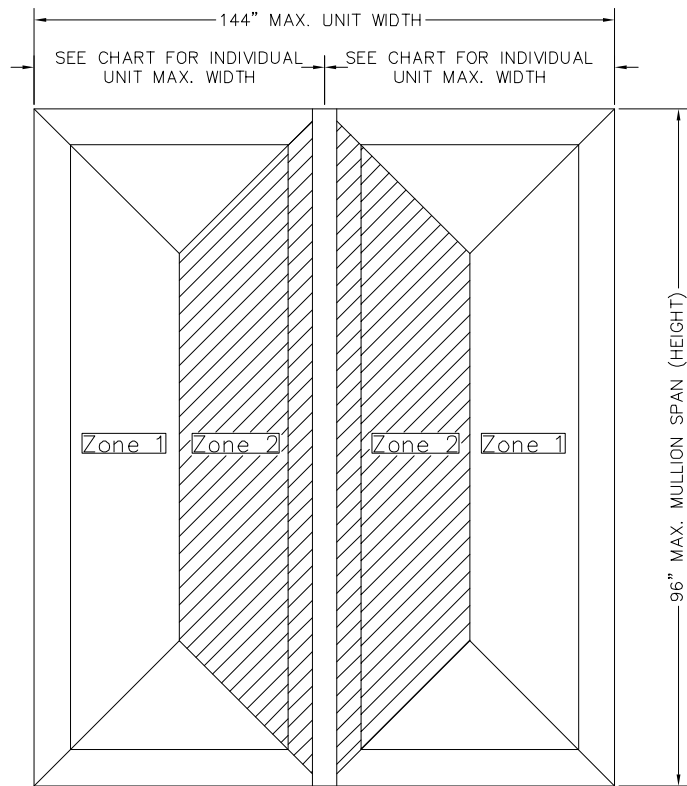

MAXIMUM INDIVIDUAL WINDOW WIDTH

WINDOW TYPE	WINDOW WIDTH
DOUBLE HUNG	56"
HORIZONTAL SLIDER	72"
CASEMENT	36"
FIXED	96"

SIMONTON WINDOWS
 1 COCHRANE AVE. PENNSBORO, WV 26415
 PH. 800-426-2249

EXTRUDED NON-IMPACT VINYL MULLIONS WITH ALUMINUM REINFORCEMENT
 ALL NON-IMPACT WINDOW SERIES

REVISIONS			
REV.	DESCRIPTION	DATE	BY
5	Updated DP ratings chart and added new mullion covers.	06/20/2012	T.D.D.
6	Updated O.C. spacing to 12" -FC 18-031.	08/08/2019	LMH
7	Update to include both horizontal & vertical views.	12/02/2019	LMH
.	.	.	.
.	.	.	.

TABLE A – MAXIMUM DESIGN PRESSURES (PSF)
 MULLION # CM0146

Mullion Length	Individual Unit Width or Height													
	24	28	32	36	40	44	48	52	56	60	64	68	72	
40	75	75	75	75	75	75	75	75	75	75	75	75	75	
44	75	75	75	75	75	75	75	75	75	75	75	75	75	
48	75	75	75	75	75	75	75	75	75	75	75	75	75	
52	75	75	75	75	75	75	75	75	75	75	75	75	75	
56	75	75	75	75	75	75	70	70	70	70	70	70	70	
60	75	75	75	75	70	65	65	65	60	60	60	60	60	
64	75	75	70	65	65	60	55	55	55	55	55	55	55	
68	75	75	65	60	55	55	50	50	50	50	45	45	45	
72	75	70	60	55	55	50	45	45	45	45	40	40	40	
76	70	65	55	50	50	45	45	40	40	40	40	40	35	
80	65	60	55	50	45	40	40	40	35	35	35	35	35	
84	65	55	50	45	40	40	35	35	35	35	30	30	30	
88	60	55	45	45	40	35	35	35	30	30	30	30	30	
92	55	50	45	40	35	35	35	30	30	30	25	25	25	
96	55	45	40	40	35	35	30	30	30	25	25	25	25	

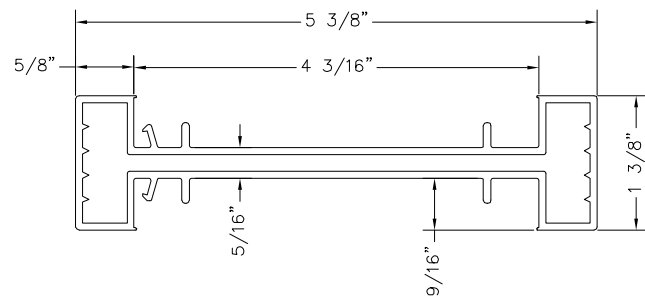

ALL FIN & J FRAMES H-MULLION
 LARGE VINYL MULLION COVER #VPI-573
 EXTRUDED VINYL .071" MIN.

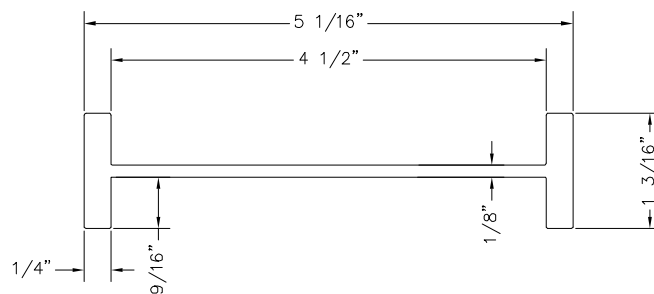

LARGE MULL REINFORCEMENT #CM0146
 ALUMINUM 6063-T6

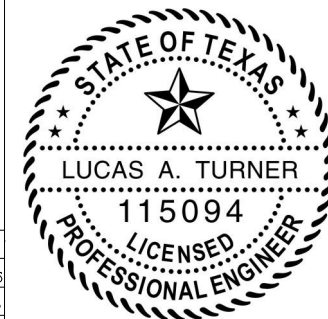
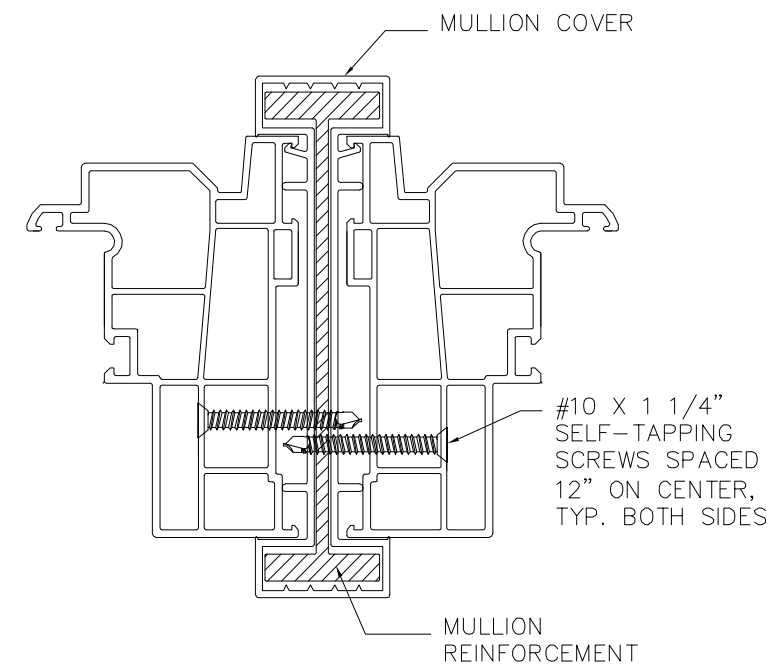

22

12/30/2019

LUCAS A. TURNER, P.E. TX PE #115094
 2428 OLD NATCHEZ TRACE TRAIL
 CAMDEN, TN 38320
 PH. 941-380-1574

SIMONTON WINDOWS

SCALE: 0.75:1 | SHEET: 2 of 8 | APPR'D BY: CAP | DATE: 01/20/12
 SERIES: ALL MULLED PRODUCTS-TDI | TITLE: REINFORCED VINYL MULLIONS!

DRAWING NUMBER: REV. C1 | RMO015B | 7
 DRAWN BY: RTW | DATE: 3-20-06
 CHECKED BY: TDD | DATE: 12/18/08
 APPROVED BY: CAP | DATE: 01/20/12

SEE NOTES SHEETS 6, 7, AND 8 FOR REQUIRED ANCHORAGE INFORMATION.

MULLION TRIBUTARY HEIGHT = SUM OF ZONE 2 WINDOW HEIGHTS

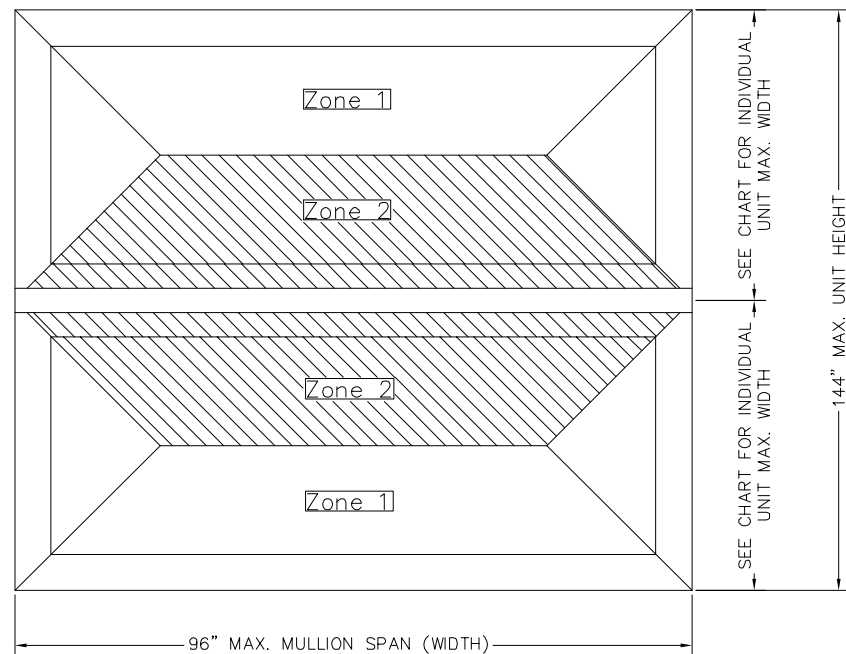

MULLION TRIBUTARY WIDTH = SUM OF ZONE 2 WINDOW WIDTHS

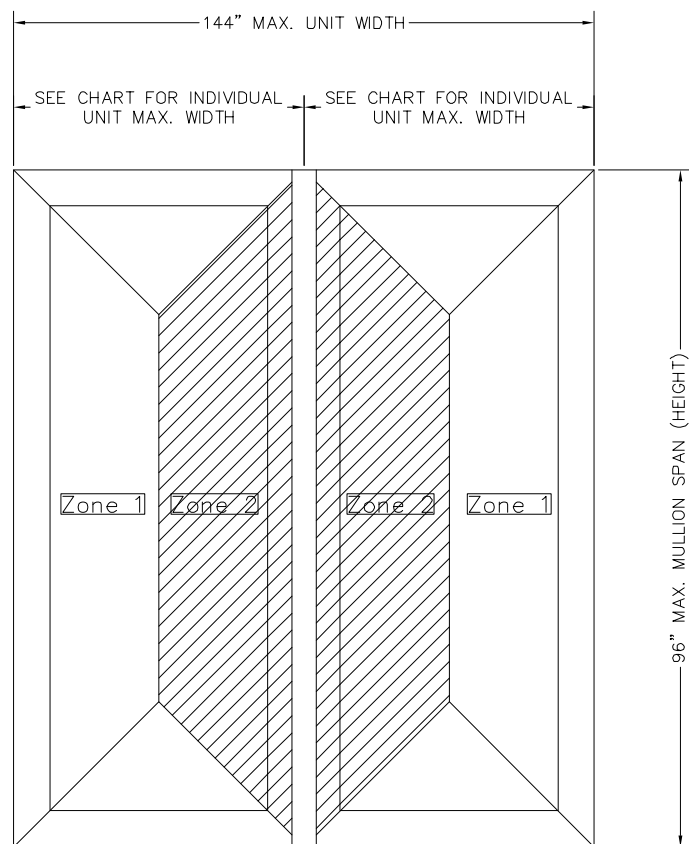

MAXIMUM INDIVIDUAL WINDOW WIDTH

WINDOW TYPE	WINDOW WIDTH
SINGLE HUNG	52"
DOUBLE HUNG	56"
HORIZONTAL SLIDER	72"
CASEMENT	36"
FIXED	96"

SIMONTON
WINDOWS
1 COCHRANE AVE. PENNSBORO, WV 26415
PH. 800-426-2249

EXTRUDED NON-IMPACT VINYL MULLIONS
WITH ALUMINUM REINFORCEMENT
ALL NON-IMPACT WINDOW SERIES

REVISIONS			
REV.	DESCRIPTION	DATE	BY
5	Updated DP ratings chart and added new mullion covers.	06/20/2012	T.D.D.
6	Updated O.C. spacing to 12" -FC 18-031.	08/08/2019	LMH
7	Update to include both horizontal & vertical views.	12/02/2019	LMH
.	.	.	.
.	.	.	.

TABLE B - MAXIMUM DESIGN PRESSURES (PSF)
MULLION #16991

Mullion Length	Individual Unit Width or Height												
	24	28	32	36	40	44	48	52	56	60	64	68	72
40	75	75	75	75	75	75	75	75	75	75	75	75	75
44	75	75	75	75	75	75	75	75	75	75	75	75	75
48	75	75	75	75	75	75	75	75	75	75	75	75	75
52	75	75	75	75	75	75	75	75	75	75	75	75	75
56	75	75	75	75	75	75	70	70	70	70	70	70	70
60	75	75	75	75	70	65	65	65	60	60	60	60	60
64	75	75	70	65	65	60	55	55	55	55	55	55	55
68	75	75	65	60	55	55	50	50	50	50	45	45	45
72	75	70	60	55	55	50	45	45	45	45	40	40	40
76	70	65	55	50	50	45	45	40	40	40	40	40	35
80	65	60	55	50	45	40	40	40	35	35	35	35	35
84	65	55	50	45	40	40	35	35	35	35	30	30	30
88	60	55	45	45	40	35	35	35	30	30	30	30	30
92	55	50	45	40	35	35	35	30	30	30	25	25	25
96	55	45	40	40	35	35	30	30	30	25	25	25	25

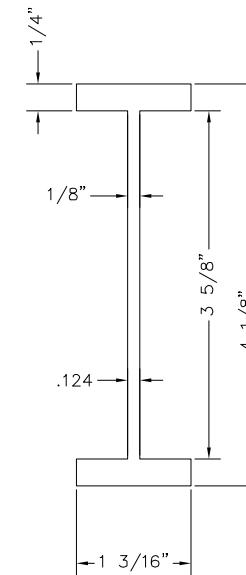

LARGE MULL
REINFORCEMENT
#16991
ALUMINUM
6063-T6

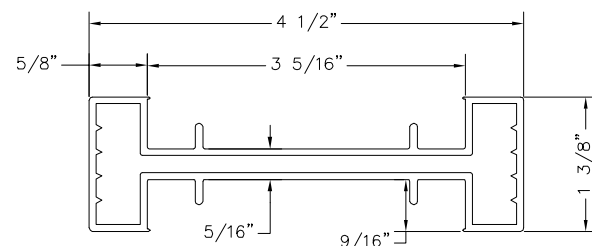

4000 SERIES RETROFIT H-MULLION
LARGE VINYL MULLION COVER #VPI-354A
EXTRUDED VINYL .071" MIN.

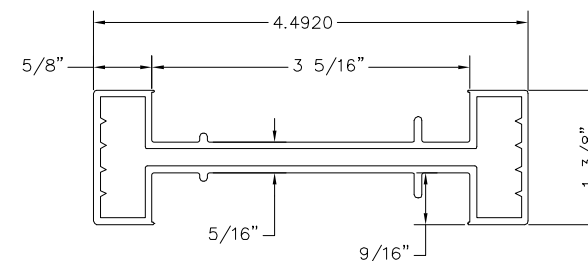

RETROFIT H-MULLION
LARGE VINYL MULLION COVER #VPI-354
EXTRUDED VINYL .071" MIN.

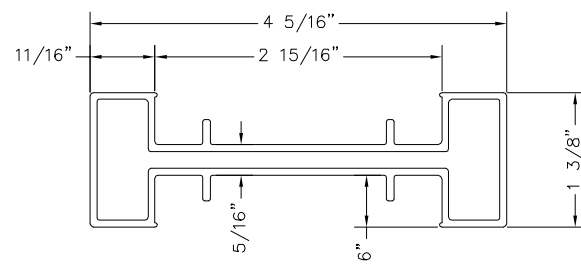

PROFINISH H-MULLION
LARGE VINYL MULLION COVER #VPI-560
EXTRUDED VINYL .079" MIN.

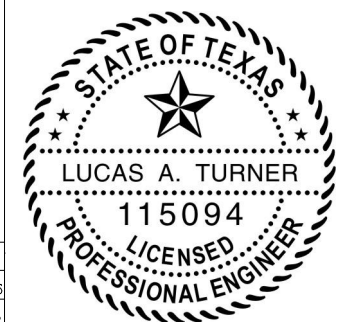
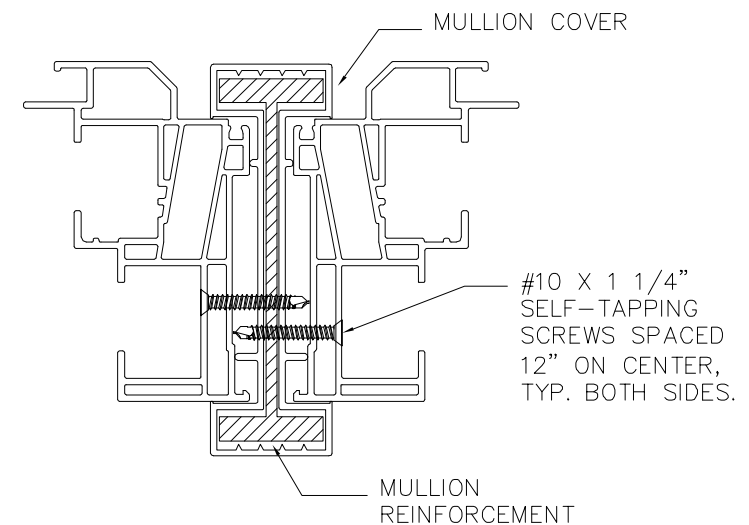

SIMONTON
WINDOWS

12/30/2019

LUCAS A. TURNER, P.E. TX PE #115094
2428 OLD NATCHEZ TRACE TRAIL
CAMDEN, TN 38320
Ph. 941-380-1574

SCALE: 0.75:1 SHEET: 3 of 8

SERIES: ALL MULLED PRODUCTS-TDI
TITLE: REINFORCED VINYL MULLIONS

SIZE: DRAWING NUMBER: REV. C1 RMO015B1 7

DRAWN BY: RTW DATE: 3-20-06

CHECKED BY: TDD DATE: 12/18/08

APPROVED BY: CAP DATE: 01/20/12

SEE NOTES SHEETS 6, 7, AND 8 FOR REQUIRED ANCHORAGE INFORMATION.

MULLION TRIBUTARY HEIGHT = SUM OF ZONE 2 WINDOW HEIGHTS

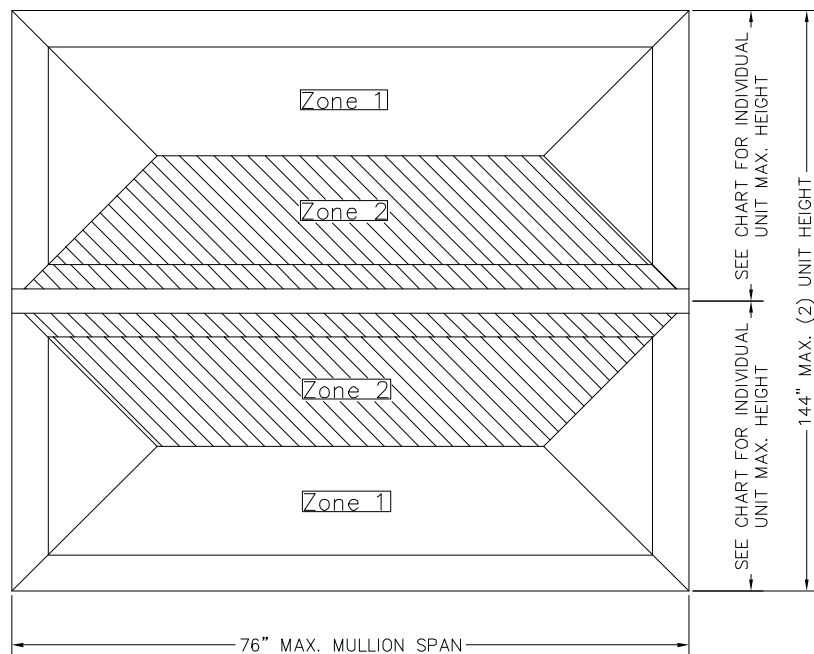

MULLION TRIBUTARY WIDTH = SUM OF ZONE 2 WINDOW WIDTHS

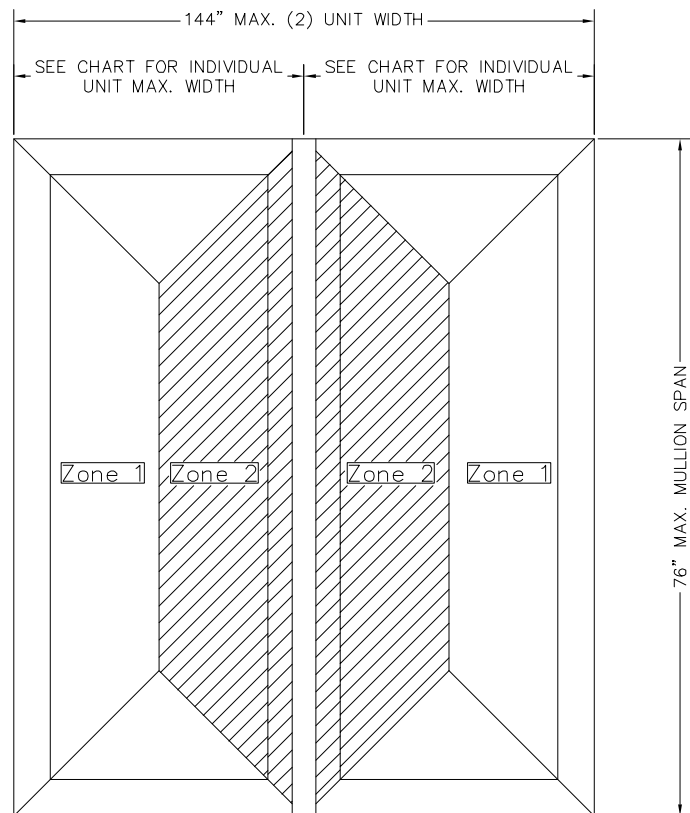

MAXIMUM INDIVIDUAL WINDOW WIDTH

WINDOW TYPE	WINDOW WIDTH
SINGLE HUNG	52"
DOUBLE HUNG	56"
HORIZONTAL SLIDER	72"
CASEMENT	36"
FIXED	96"

SIMONTON WINDOWS
 1 COCHRANE AVE. PENNSBORO, WV 26415
 PH. 800-426-2249
 EXTRUDED NON-IMPACT VINYL MULLIONS
 WITH ALUMINUM REINFORCEMENT
 ALL NON-IMPACT WINDOW SERIES

REVISIONS			
REV.	DESCRIPTION	DATE	BY
5	Updated DP ratings chart and added new mullion covers.	06/20/2012	T.D.D.
6	Updated O.C. spacing to 12" -FC 18-031.	08/08/2019	LMH
7	Update to include both horizontal & vertical views.	12/02/2019	LMH
.	.	.	.
.	.	.	.

TABLE C - MAXIMUM DESIGN PRESSURES (PSF)
 MULLION #16990

Mullion Length	Individual Unit Width or Height													
	24	28	32	36	40	44	48	52	56	60	64	68	72	
40	75	75	75	75	75	75	75	75	75	75	75	75	75	
44	75	75	75	75	75	75	75	75	75	75	75	75	75	
48	75	75	75	75	75	75	75	75	75	75	75	75	75	
52	75	75	75	75	75	75	70	70	70	70	70	70	70	
56	75	75	70	65	60	60	55	55	55	55	55	55	55	
60	70	60	55	50	50	45	45	40	40	40	40	40	40	
64	60	50	45	40	40	35	35	35	30	30	30	30	30	
68	45	40	35	35	30	30	25	25	25	25	25	25	25	
72	40	35	30	25	25	25	20	20	20	20	20	20	20	
76	35	30	25	20	20	20	20	15	15	15	15	15	15	

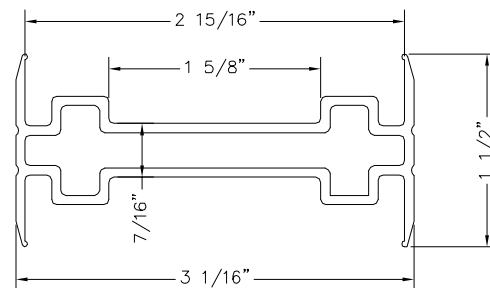

MEDIUM H-MULLION VINYL COVER #VPI-346A
 ALL NEW CONSTRUCTION
 EXTRUDED VINYL .071" MIN.

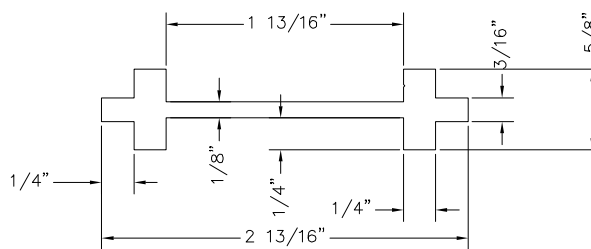

MEDIUM MULL REINFORCEMENT #16990
 ALUMINUM 6063-T6

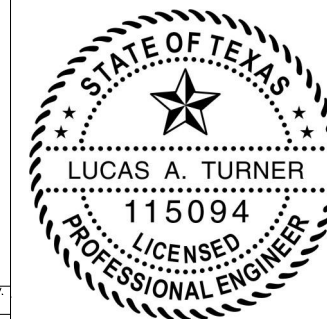
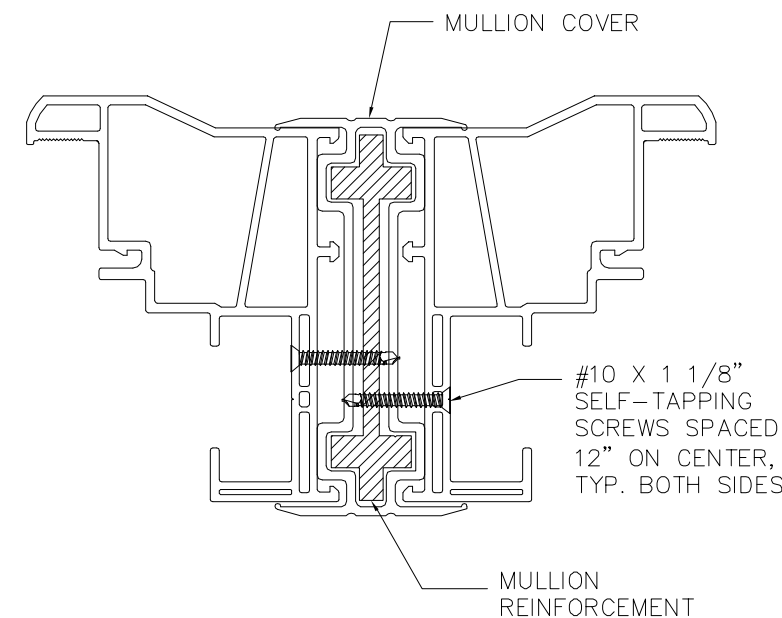

SEE NOTES SHEETS 6, 7, AND 8 FOR REQUIRED ANCHORAGE INFORMATION.

ZZ
 12/30/2019
 LUCAS A. TURNER, P.E. TX PE #115094
 2428 OLD NACHEZ TRACE TRAIL
 CAMDEN, TN 38320
 Ph. 941-380-1574

SIMONTON WINDOWS
 DRAWN BY: RTW
 CHECKED BY: TDD
 DATE: 01/20/12

SCALE: 0.75:1 SHEET: 4 of 8
 SERIES: ALL MULLED PRODUCTS-TDI
 TITLE: REINFORCED VINYL MULLIONS

SIZE: DRAWING NUMBER: REV. C1 RMO015B1 7
 DATE: 3-20-06
 DATE: 12/18/08
 DATE: 01/20/12

MULLION TRIBUTARY HEIGHT = SUM OF ZONE 2 WINDOW HEIGHTS

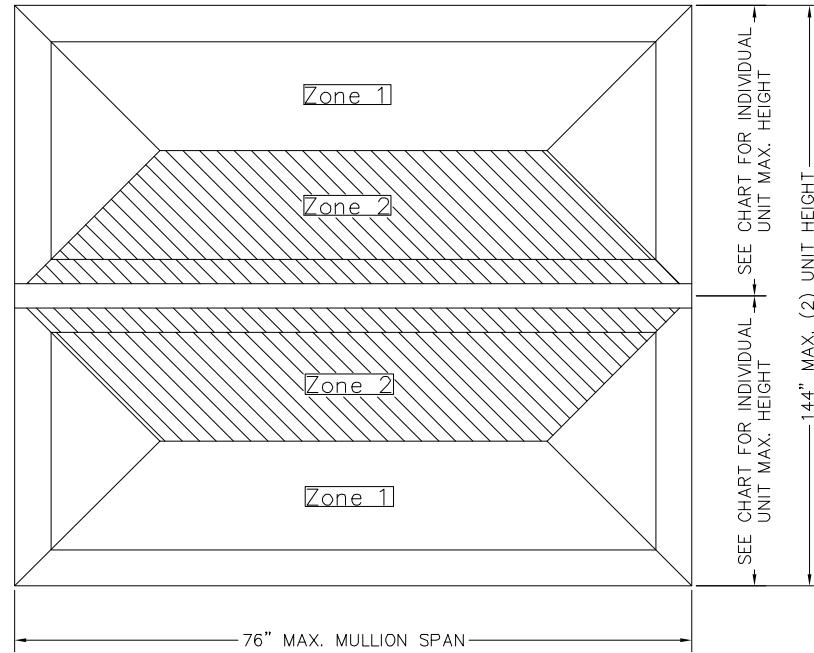

MULLION TRIBUTARY WIDTH = SUM OF ZONE 2 WINDOW WIDTHS

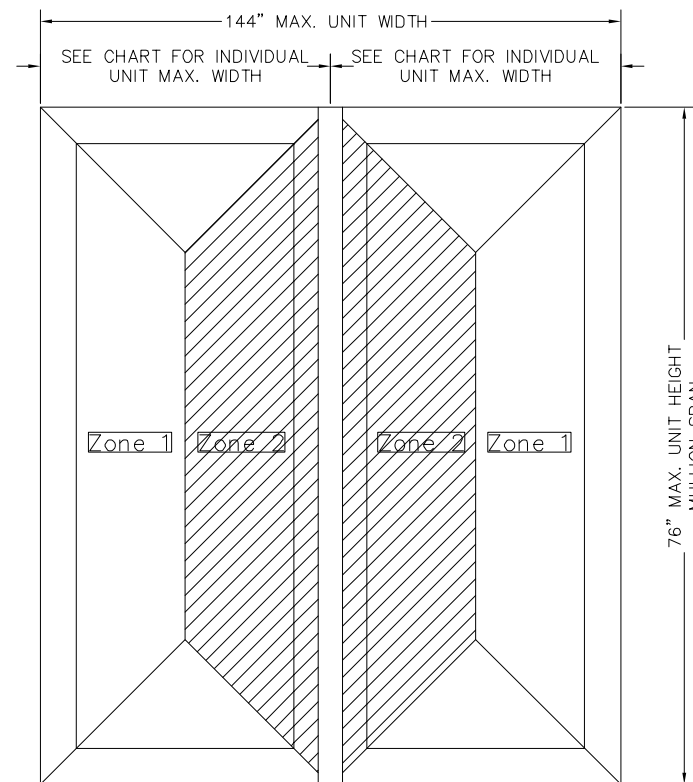

MAXIMUM SINGLE WINDOW WIDTH

WINDOW TYPE	WINDOW WIDTH
DOUBLE HUNG	56"
HORIZONTAL SLIDER	72"
CASEMENT	36"
FIXED	96"

SEE NOTES ON SHEETS 6, 7, AND 8 FOR REQUIRED ANCHORAGE INFORMATION.



1 COCHRANE AVE. PENNSBORO, WV 26415
PH. 800-426-2249

EXTRUDED NON-IMPACT VINYL MULLIONS WITH ALUMINUM REINFORCEMENT ALL NON-IMPACT WINDOW SERIES

REVISIONS

REV.	DESCRIPTION	DATE	BY
5	Updated DP ratings chart and added new mullion covers.	06/20/2012	T.D.D.
6	Updated O.C. spacing to 12" -FC 18-031.	08/08/2019	LMH
7	Update to include both horizontal & vertical views.	12/02/2019	LMH
.	.	.	.
.	.	.	.

TABLE D - MAXIMUM DESIGN PRESSURES (PSF)
MULLION # 20634

Mullion Length	Individual Unit Width or Height													
	24	28	32	36	40	44	48	52	56	60	64	68	72	
40	75	75	75	75	75	75	75	75	75	75	75	75	75	
44	75	75	75	75	75	75	75	75	75	75	75	75	75	
48	75	75	75	75	75	75	75	75	75	75	75	75	75	
52	75	75	75	75	75	75	75	75	75	75	75	75	75	
56	75	75	75	70	65	60	60	60	60	60	60	60	60	
60	75	65	60	55	50	50	45	45	45	45	45	45	45	
64	60	55	50	45	40	40	35	35	35	35	35	35	35	
68	50	45	40	35	30	30	25	25	25	25	25	25	25	
72	40	35	30	30	25	25	25	20	20	20	20	20	20	
76	35	30	25	25	20	20	20	20	15	15	15	15	15	

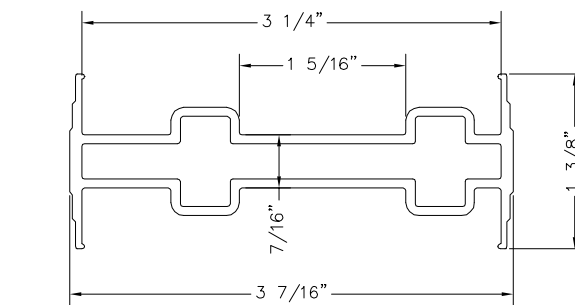

4000 SERIES MEDIUM VINYL H-MULLION COVER #MP0347
EXTRUDED VINYL 0.070" MIN.

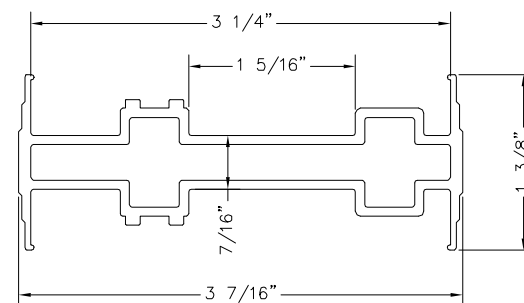

MEDIUM H-MULLION VINYL COVER #VPI-436
FOR ANY RETROFIT HOOKED FRAME
EXTRUDED VINYL .070" MIN.

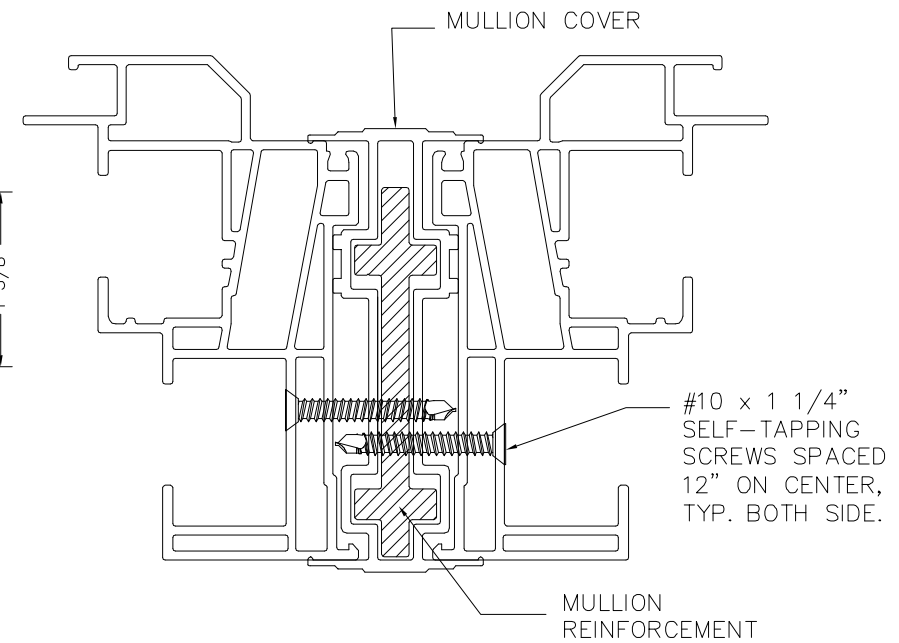

MEDIUM MULL REINFORCEMENT #20634
ALUMINUM 6063-T6

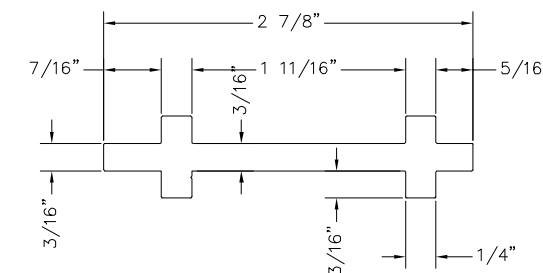

MEDIUM MULL REINFORCEMENT #20634
ALUMINUM 6063-T6

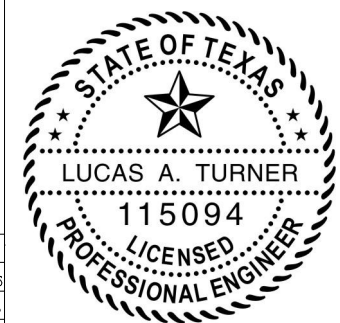

DRAWING NUMBER: REV. 7
 C1 RM0015B
 DRAWN BY: RTW DATE: 3-20-06
 CHECKED BY: TDD DATE: 12/18/08
 APPROVED BY: CAP DATE: 01/20/12
 SCALE: 0.75:1 SHEET: 5 of 8
 SERIES: ALL MULLED PRODUCTS-TDI
 TITLE: REINFORCED VINYL MULLIONS!



1 COCHRANE AVE. PENNSBORO, WV 26415
PH. 800-426-2249

EXTRUDED NON-IMPACT VINYL MULLIONS
WITH ALUMINUM REINFORCEMENT
ALL NON-IMPACT WINDOW SERIES

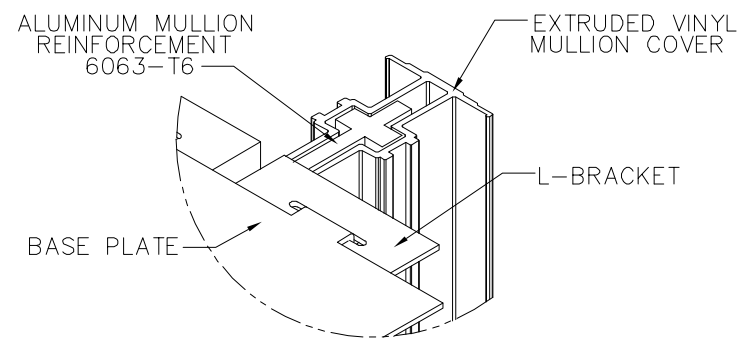

DETAIL A MEDIUM MULLIONS

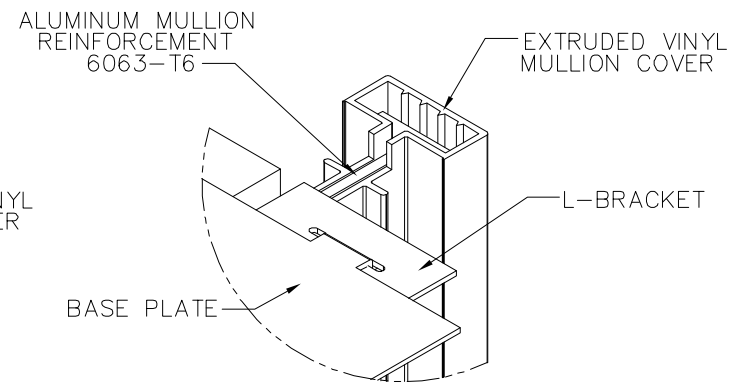

DETAIL A LARGE MULLIONS

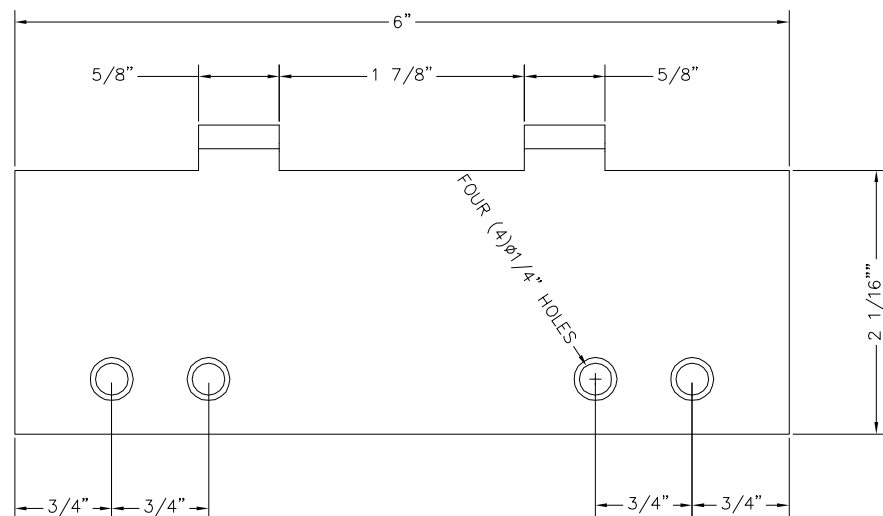

REINFORCEMENT BASE PLATE DETAIL
.060" MIN. STAINLESS STEEL
ANSI 302/304

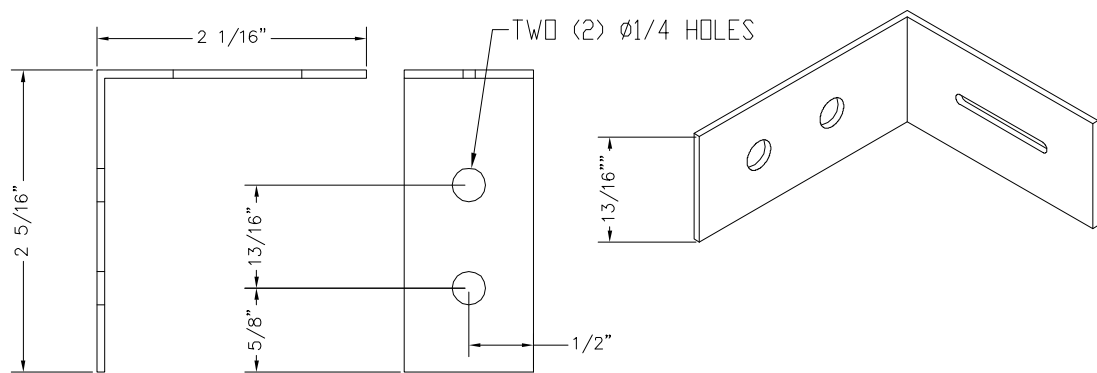

REINFORCEMENT L-BRACKET
.076" MIN. STAINLESS STEEL
ANSI 302/304

INSTALLATION INSTRUCTIONS FOR ATTACHING
REINFORCED MULLIONS TO WINDOW UNITS.
TYPICALLY, USE SELF-TAPPING SCREW OF
SUFFICIENT LENGTH TO FULLY ENGAGE
THREADS THROUGH THE ALUMINUM REINF.,
SPACED 6" FROM HEAD & SILL THEN 12' O.C.

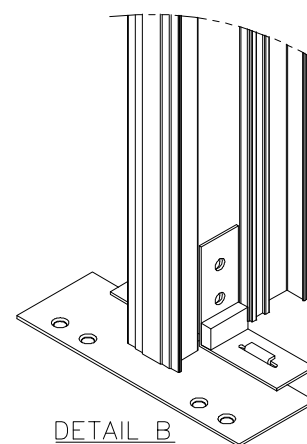

DETAIL B

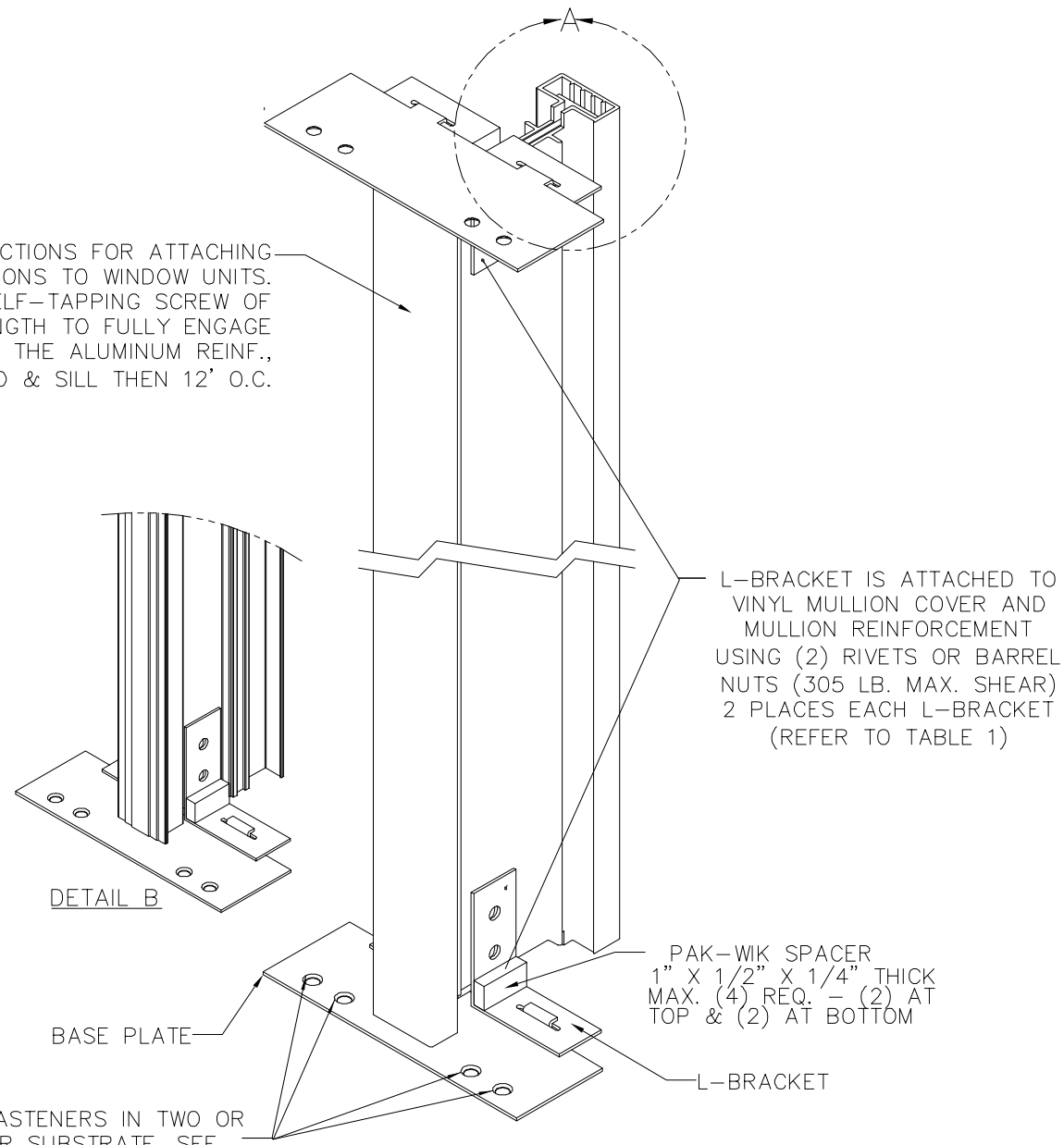

ASSEMBLED MULLION ATTACHMENT VIEW

LARGE MULLION SHOWN, MEDIUM MULLION SIMILAR,
SEE DETAIL B FOR MEDIUM ATTACHMENT VIEW AT SILL

L-BRACKET IS ATTACHED TO
VINYL MULLION COVER AND
MULLION REINFORCEMENT
USING (2) RIVETS OR BARREL
NUTS (305 LB. MAX. SHEAR)
2 PLACES EACH L-BRACKET
(REFER TO TABLE 1)

PAK-WIK SPACER
1" X 1/2" X 1/4" THICK
MAX. (4) REQ. - (2) AT
TOP & (2) AT BOTTOM

INSTALLATION FASTENERS IN TWO OR
FOUR HOLES PER SUBSTRATE, SEE
SHEETS 7 AND 8

REVISIONS			
REV.	DESCRIPTION	DATE	BY
5	Updated DP ratings chart and added new mullion covers.	06/20/2012	T.D.D.
6	Updated O.C. spacing to 12" -FC 18-031.	08/08/2019	LMH
7	Update to include both horizontal & vertical views.	12/02/2019	LMH
.	.	.	.
.	.	.	.

TABLE 1 - MULLION ATTACHING HARDWARE

RIVET	.25 DIA. STEEL RIVET WITH A GRIP LENGTH OF .50 MAX.
BARREL NUT	#10-24 OR #10-32 STAINLESS STEEL BARREL NUT. .250 O.D. X .25" LG WITH .125 MIN ENGAGEMENT

NOTES:

- WOOD FRAME: USE (4) #10 X 1 3/4" WOOD SCREWS AT THE HEAD AND SILL THROUGH BASE PLATES, WITH 1-1/2" MINIMUM EMBEDMENT INTO WOOD FOR MULLION ATTACHMENT. SEE SHEET 7 FOR DETAILS.
- SOLID CONCRETE: USE (2) I.T.W. ADVANCED THREADFORM TECHNOLOGY TAPCON ANCHORS AT HEAD AND SILL THROUGH BASE PLATES, WITH 1 3/4" MINIMUM EMBEDMENT FOR MULLION ATTACHMENT. SEE SHEET 8 FOR DETAILS.
- TWO (2) RIVETS OR BARREL NUTS ARE REQUIRED TO ATTACH L-BRACKETS TO ALUMINUM MULLION. SEE TABLE 1 (THIS SHEET).

27

12/30/2019

LUCAS A. TURNER, P.E. TX PE #115094
2428 OLD NATCHEZ TRACE TRAIL
CAMDEN, TN 38320
Ph. 941-380-1574

SCALE: 0.75:1 SHEET: 6 of 8

SERIES: ALL MULLED PRODUCTS-TDI
TITLE: REINFORCED VINYL MULLIONS

SIMONTON WINDOWS

DRAWN BY: RTW DATE: 3-20-06
CHECKED BY: TDD DATE: 12/18/08
APPROV'D BY: CAP DATE: 01/20/12

2
C1 RMO015B1 7

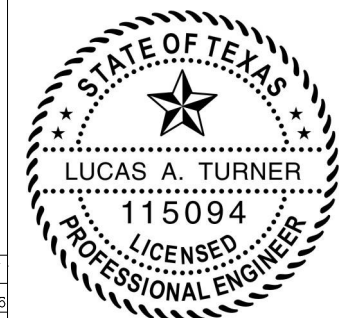



1 COCHRANE AVE. PENNSBORO, WV 26415
PH. 800-426-2249

EXTRUDED NON-IMPACT VINYL MULLIONS
WITH ALUMINUM REINFORCEMENT
ALL NON-IMPACT WINDOW SERIES

REVISIONS			
REV.	DESCRIPTION	DATE	BY
5	Updated DP ratings chart and added new mullion covers.	06/20/2012	T.D.D.
6	Updated O.C. spacing to 12" -FC 18-031.	08/08/2019	LMH
7	Update to include both horizontal & vertical views.	12/02/2019	LMH
.	.	.	.
.	.	.	.

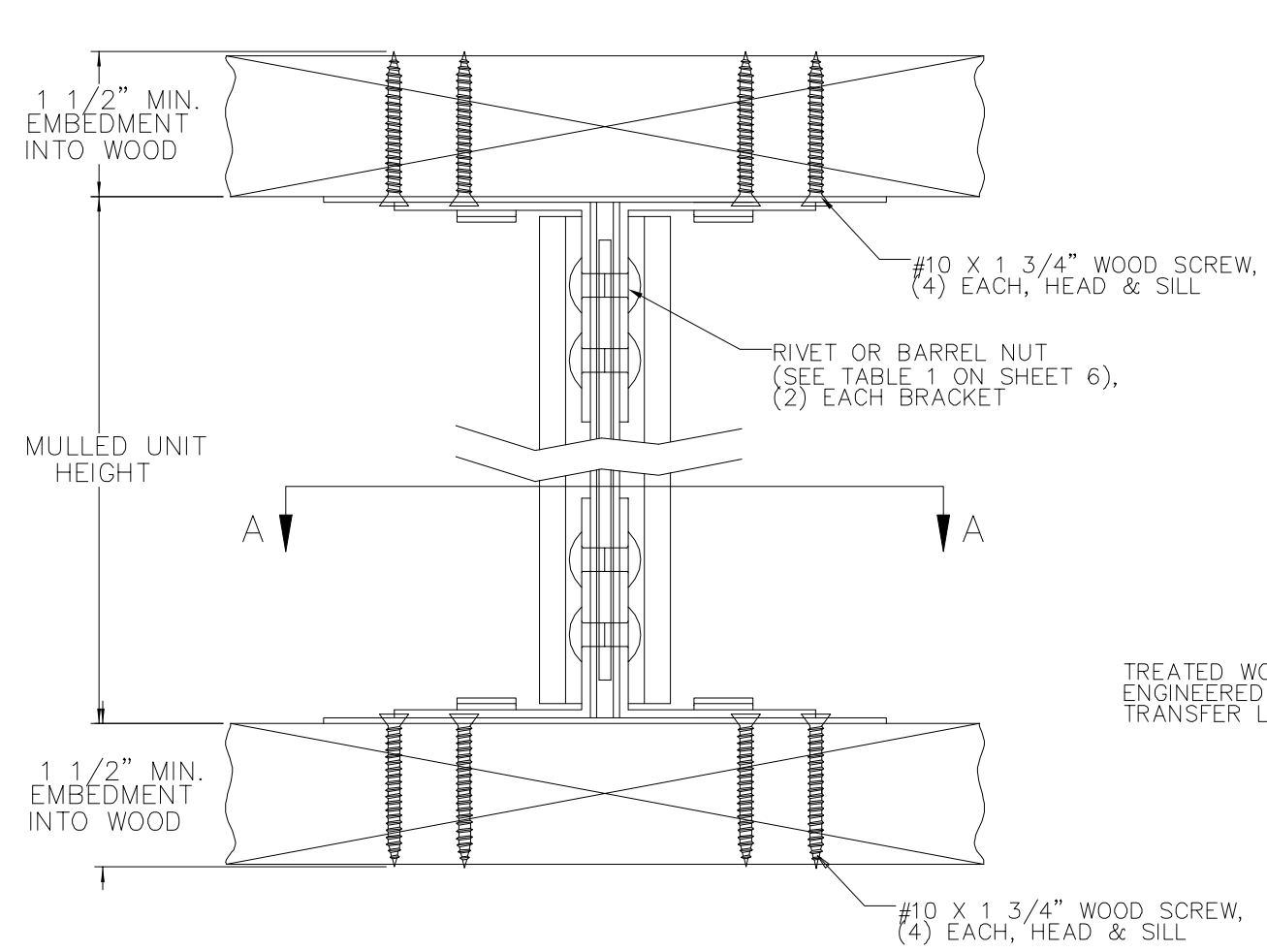

VERTICAL CROSS SECTION WITH 2X WOOD SUBSTRATE

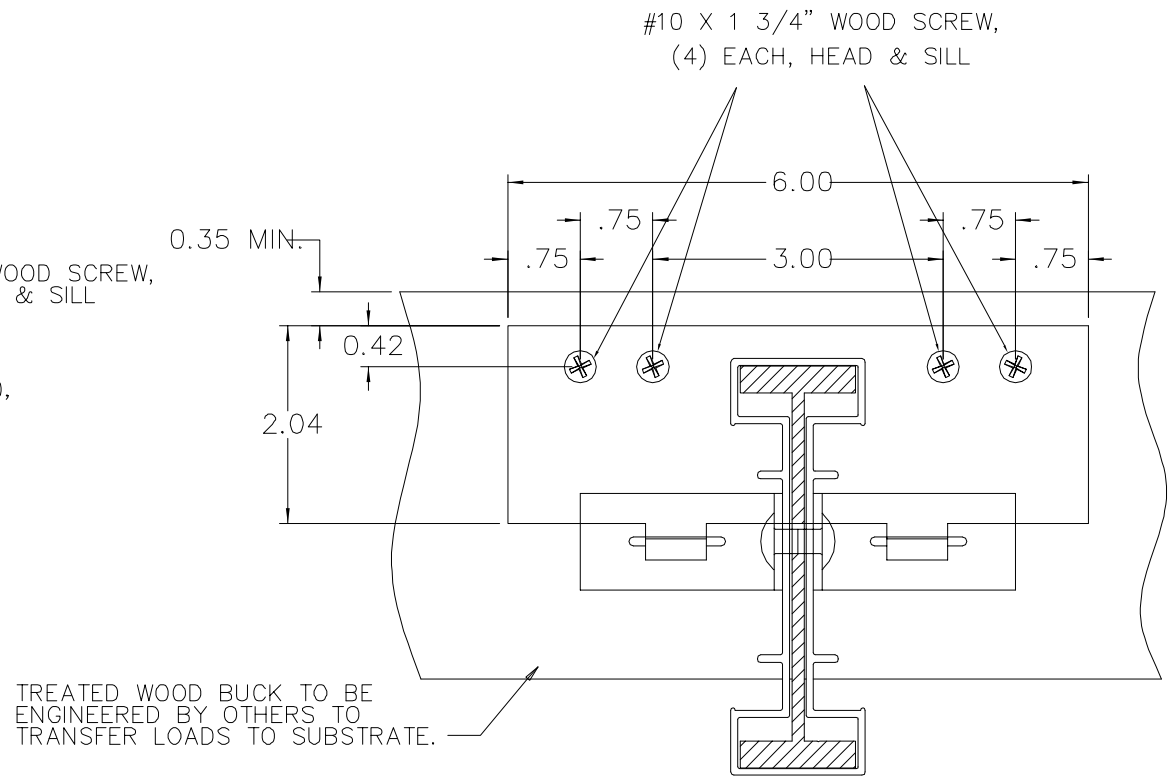

TREATED WOOD BUCK TO BE ENGINEERED BY OTHERS TO TRANSFER LOADS TO SUBSTRATE.

SECTION A-A

NOTES:

1. THE MULLION PRODUCTS AND THEIR INSTALLATION COMPLY WITH THE 2006 INTERNATIONAL RESIDENTIAL CODE WITH TEXAS REVISIONS EFFECTIVE JAN. 1, 2008
2. THE MULLIONS SHALL BE USED IN CONNECTION WITH APPROVED PRODUCTS.
3. ANCHORS SHALL HAVE 1 1/2" MINIMUM EMBEDMENT INTO WOOD AND 7/8" MINIMUM WOOD EDGE DISTANCE.
4. ATTACHMENT OF ALL 2X TREATED WOOD BUCKS SHALL BE ENGINEERED SEPARATELY BY OTHERS.
5. WOOD SHALL BE TREATED 2X SPRUCE, PINE, OR FIR.
6. #10 WOOD SCREWS SHALL BE STEEL CONFORMING TO ASTM A 653.
7. BASE PLATES AND L-BRACKETS ARE STAINLESS STEEL CONFORMING TO ANSI 302/304.
8. SIMILAR INSTALLATIONS ARE USED ON HEAD AND SILL.
9. WHEN INSTALLED IN LOCATIONS WHERE WINDBORNE DEBRIS PROTECTION IS REQUIRED, USE OF AN IMPACT PROTECTIVE SYSTEM IS REQUIRED.

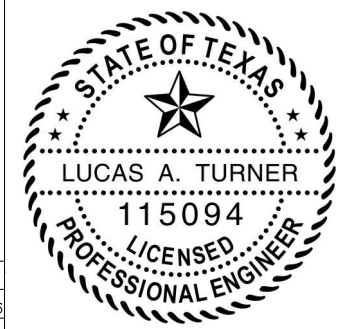

	SCALE: 0.75:1	SHEET: 7 of 8	APPROVED BY: CAP	DATE: 01/20/12
	LUCAS A. TURNER, P.E. TX PE #115094 2428 OLD NATCHEZ TRACE TRAIL CAMDEN, TN 38320 Ph. 941-380-1574		DRAWING NUMBER: REV. 7 C1 RMO015B1	



1 COCHRANE AVE. PENNSBORO, WV 26415
PH. 800-426-2249

EXTRUDED NON-IMPACT VINYL MULLIONS
WITH ALUMINUM REINFORCEMENT
ALL NON-IMPACT WINDOW SERIES

REVISIONS			
REV.	DESCRIPTION	DATE	BY
5	Updated DP ratings chart and added new mullion covers.	06/20/2012	T.D.D.
6	Updated O.C. spacing to 12" -FC 18-031.	08/08/2019	LMH
7	Update to include both horizontal & vertical views.	12/02/2019	LMH
.	.	.	.
.	.	.	.

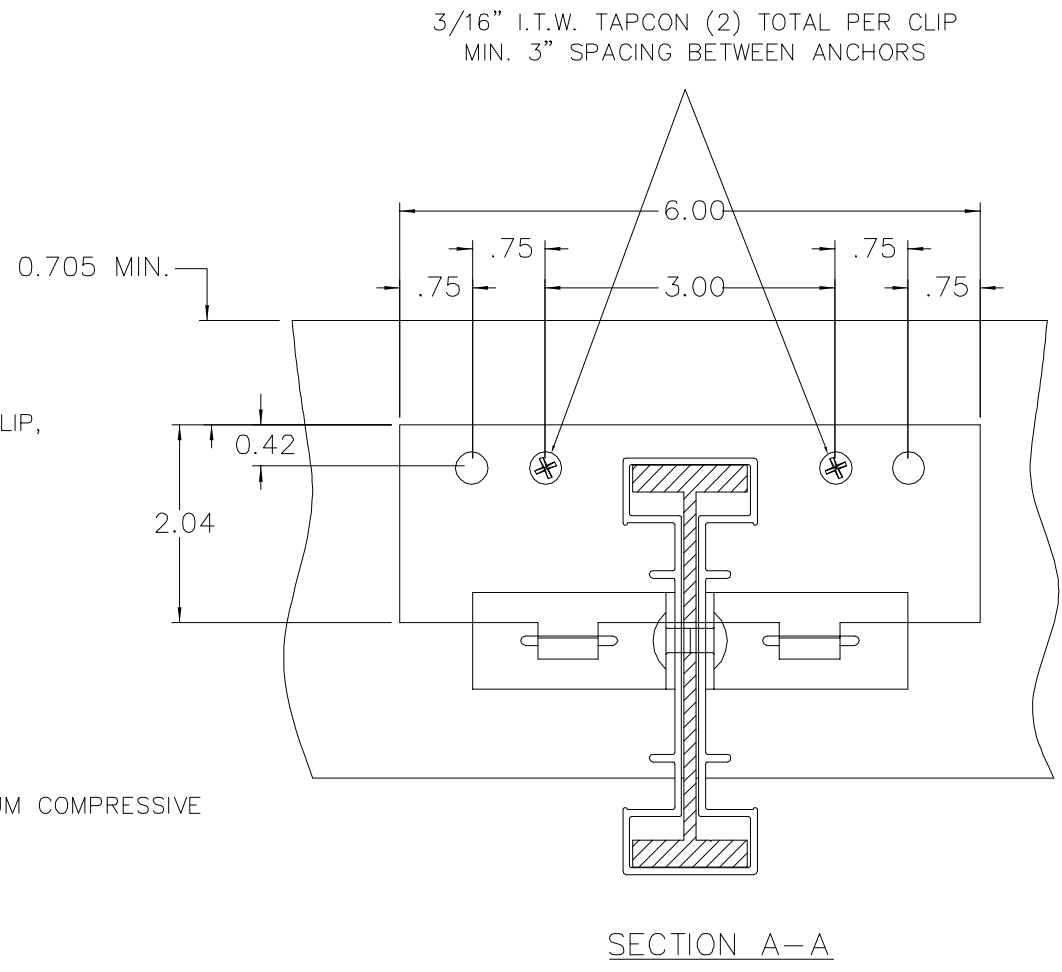
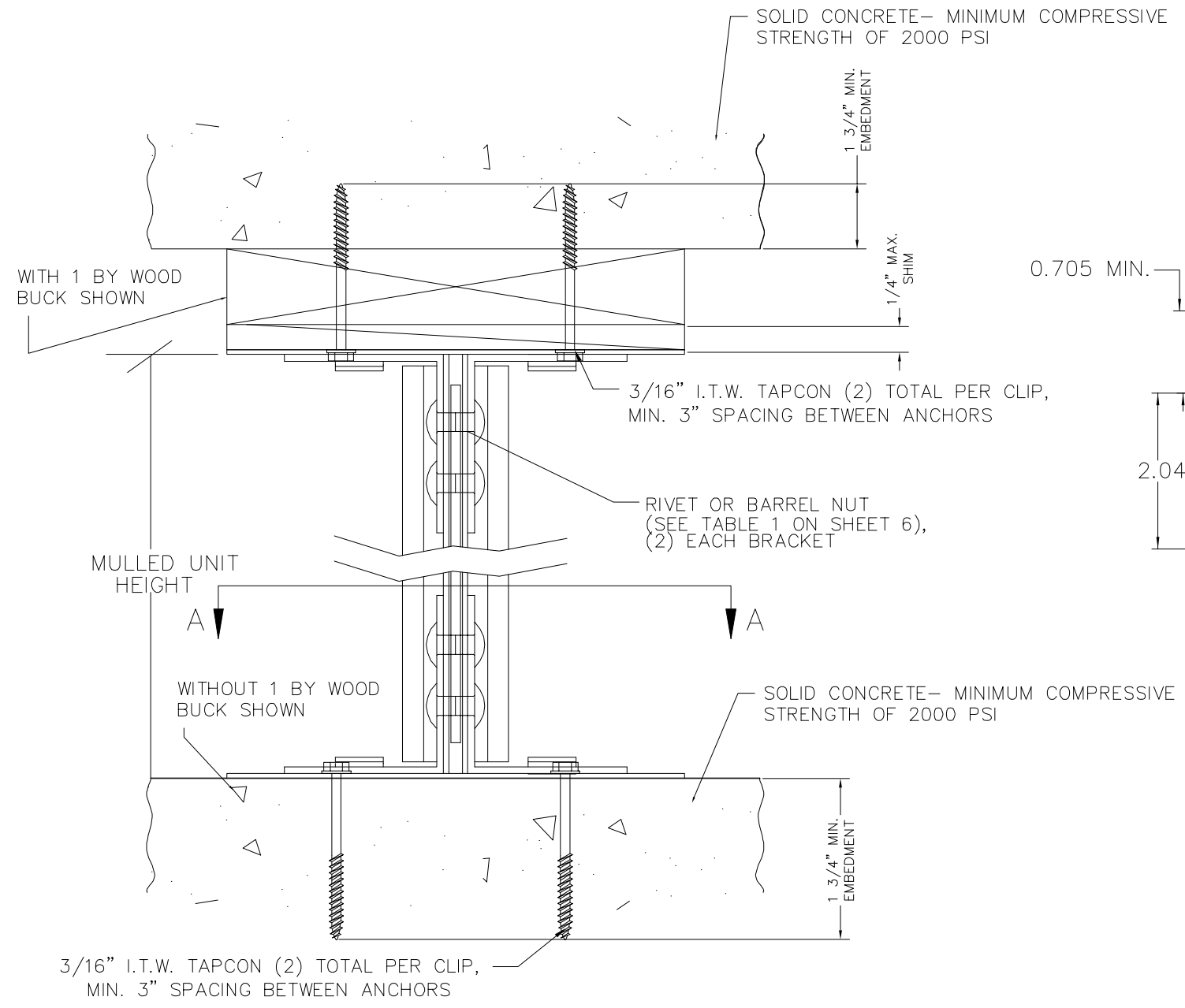

VERTICAL CROSS SECTION WITH
CONCRETE SUBSTRATE

SECTION A-A

- NOTES:
1. THE MULLION PRODUCTS AND THEIR INSTALLATION COMPLY WITH THE 2006 INTERNATIONAL RESIDENTIAL CODE WITH TEXAS REVISIONS EFFECTIVE JAN. 1, 2008.
 2. THE MULLIONS SHALL BE USED IN CONNECTION WITH TDI APPROVED PRODUCTS.
 3. ANCHORS SHALL HAVE 1 3/4" MINIMUM EMBEDMENT & 1 1/8" MINIMUM EDGE DISTANCE FOR SOLID CONCRETE.
 4. ATTACHMENT OF ALL TREATED WOOD BUCKS SHALL BE ENGINEERED SEPARATELY BY OTHERS.
 5. WOOD SHALL BE TREATED SPRUCE, PINE, OR FIR.
 6. I.T.W. ADVANCED THREADFORM TECHNOLOGY TAPCONS OR EQUAL SHALL BE GRADE 5 HEAT TREATED STEEL WITH CORROSION RESISTANT COATING.
 7. BASE PLATES AND L-BRACKETS ARE STAINLESS STEEL CONFORMING TO ANSI 302/304.
 8. SIMILAR INSTALLATIONS ARE USED ON HEAD AND SILL.
 9. WHEN INSTALLED IN LOCATIONS WHERE WINDBORNE DEBRIS PROTECTION IS REQUIRED, USE OF AN IMPACT PROTECTIVE SYSTEM IS REQUIRED.

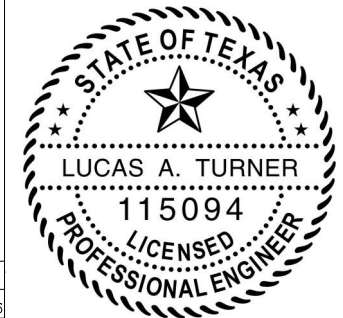

 12/30/2019 LUCAS A. TURNER, P.E. TX PE #115094 2428 OLD NATCHEZ TRACE TRAIL CAMDEN, TN 38320 Ph. 941-360-1574		SIZE: DRAWING NUMBER: REV. C1 RMO015B 7
	SCALE: 0.75:1 SHEET: 8 of 8 SERIES: ALL MULLED PRODUCTS-TDI TITLE: REINFORCED VINYL MULLIONS	DRAWN BY: RTW DATE: 3-20-06 CHECKED BY: TDD DATE: 12/18/08 APPROV'D BY: CAP DATE: 01/20/12