

NOTES:

1. THE PRODUCT SHOWN HEREIN IS DESIGNED AND MANUFACTURED TO COMPLY WITH REQUIREMENTS OF THE INTERNATIONAL BUILDING CODE AND THE RESIDENTIAL CODE WITH STATE OF TEXAS MODIFICATIONS.
2. WOOD FRAMING TO BE DESIGNED AND ANCHORED TO PROPERLY TRANSFER ALL LOADS TO STRUCTURE. FRAMING IS THE RESPONSIBILITY OF THE ARCHITECT OR ENGINEER OF RECORD.
3. ALLOWABLE STRESS INCREASE OF 1/3 WAS NOT USED IN THE DESIGN OF THE PRODUCT SHOWN HEREIN. WIND LOAD DURATION FACTOR Cd=1.6 WAS USED FOR WOOD ANCHOR CALCULATIONS.
4. APPROVED IMPACT PROTECTIVE SYSTEM IS NOT REQUIRED FOR THIS PRODUCT IN WIND BORNE DEBRIS REGIONS UP TO WIND ZONE 3.
5. DESIGN PRESSURE AND INSTALLATION DETAILS SHOWN IN THIS DOCUMENT APPLY ONLY TO MULLION. FENESTRATION UNITS MUST BE APPROVED UNDER SEPARATE APPROVAL.
6. SINGLE FENESTRATION UNITS TO BE MULLED ARE NOT LIMITED TO THOSE SHOWN IN THIS DRAWING. FENESTRATION UNITS MUST BE MANUFACTURED BY WinDoor INC.
7. DESIGN PRESSURE OF MULLED UNIT SHALL BE CONTROLLED BY THE LESSER DESIGN PRESSURE OF THE MULLION OR THE INDIVIDUAL FENESTRATION UNIT.
8. UNITS MAY BE MULLED TOGETHER INDEFINITELY AS LONG AS SINGLE UNIT WIDTH AND HEIGHT ARE NOT EXCEEDED AND MULLION IS ANCHORED AS SHOWN HEREIN.
9. MULLION VERTICAL INSTALLATION IS SHOWN, MULLION MAY BE USED IN HORIZONTAL APPLICATIONS AS LONG AS DIMENSIONS INDICATED HEREIN ARE NOT EXCEEDED AND MULLION IS ANCHORED ACCORDING TO THIS DOCUMENT.

REVISIONS			
REV	DESCRIPTION	DATE	APPROVED

ANCHORING NOTES:

1. FOR ANCHORING INTO WOOD FRAMING OR 2X BUCK USE #12 WOOD SCREW WITH SUFFICIENT LENGTH TO ACHIEVE A 1 5/8" MINIMUM EMBEDMENT. LOCATE ANCHORS AS SHOWN IN INSTALLATION DETAILS.
2. FOR ANCHORING INTO CONCRETE USE 1/4" TAPCON WITH SUFFICIENT LENGTH TO ACHIEVE A 1 3/4" MINIMUM EMBEDMENT WITH 2 1/2" MINIMUM EDGE DISTANCE. LOCATE ANCHORS AS SHOWN IN INSTALLATION DETAILS.
3. FOR ANCHORING INTO METAL STRUCTURE USE #12 SMS OR SELF DRILLING SCREWS WITH SUFFICIENT LENGTH TO ACHIEVE 3 THREADS MINIMUM BEYOND STRUCTURE INTERIOR WALL. LOCATE ANCHORS AS SHOWN IN ELEVATIONS AND INSTALLATION DETAILS.
4. ALL FASTENERS TO BE CORROSION RESISTANT.
5. FOR ATTACHING WINDOW UNITS TO MULLION USE #10 SELF DRILLING SCREWS WITH SUFFICIENT LENGTH TO ACHIEVE A MINIMUM EMBEDMENT OF THREE THREADS PAST THE MULLION WALL. LOCATE SCREWS 6" FROM EACH MULLION END AND 24" MAX. O.C. THEREAFTER. STAGGER SCREWS AT EACH WINDOW.
6. FOR WINDOW AND DOOR UNITS ANCHORING SCHEDULE REFER TO WINDOW AND DOOR APPROVED INSTALLATION INSTRUCTIONS.
7. ALL FASTENERS TO BE CORROSION RESISTANT.
8. INSTALLATION ANCHORS SHALL BE INSTALLED IN ACCORDANCE WITH ANCHOR MANUFACTURER'S INSTALLATION INSTRUCTIONS, AND ANCHORS SHALL NOT BE USED IN SUBSTRATES WITH STRENGTHS LESS THAN THE MINIMUM STRENGTH SPECIFIED BELOW:
 - A. WOOD – MINIMUM SPECIFIC GRAVITY OF G=0.42
 - B. CONCRETE – MINIMUM COMPRESSIVE STRENGTH OF 3,200 PSI.
 - C. MASONRY – STRENGTH CONFORMANCE TO ASTM C-90, GRADE N, TYPE 1 (OR GREATER).
 - D. METAL STRUCTURE: STEEL 18GA, 33KSI OR ALUMINUM 6063-T5 1/8" THICK MINIMUM
9. TO ATTACH MULLION TO CLIP USE (2) 1/4" X 1" SELF DRILLING SCREWS PER CLIP. SCREWS MUST BE FIELD INSTALLED. HOLES FOR SCREWS IN MULLION ARE PRE-DRILLED BY MANUFACTURER.

SIGNED: 07/15/2013

TABLE OF CONTENTS	
SHEET NO.	DESCRIPTION
1	NOTES
2	ELEVATIONS & CHART
3	INSTALLATION DETAILS
4	COMPONENTS

		7500 AMSTERDAM DRIVE ORLANDO, FL 32832 Phone: 407.481.8400 Fax: 407.481.0505 www.windoorinc.com	
4"x4"x1/4" TUBE MULLION VERTICAL IMPACT NOTES			
DRAWN: V.L.		DWG NO. 08-01691	
SCALE NTS		DATE 07/23/12	
		SHEET 1 OF 4	



Luis R. Lomas P.E.
TX No.: 101889

REVISIONS			
REV	DESCRIPTION	DATE	APPROVED

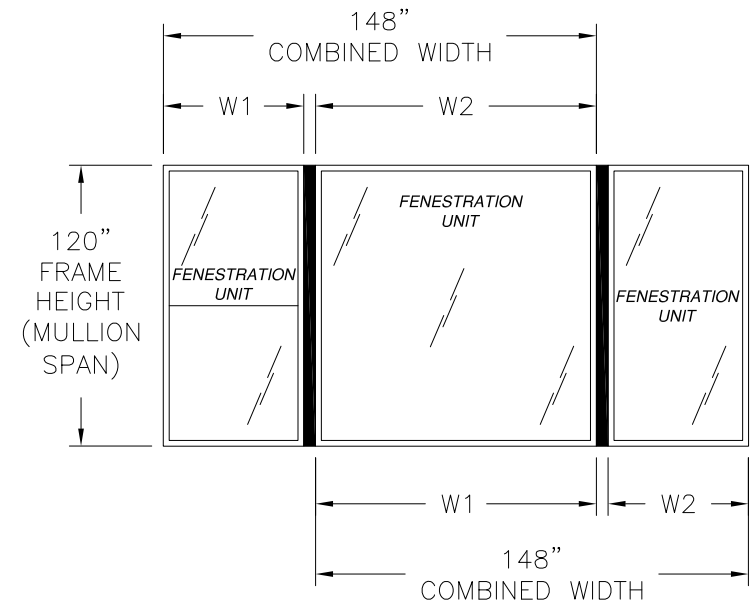
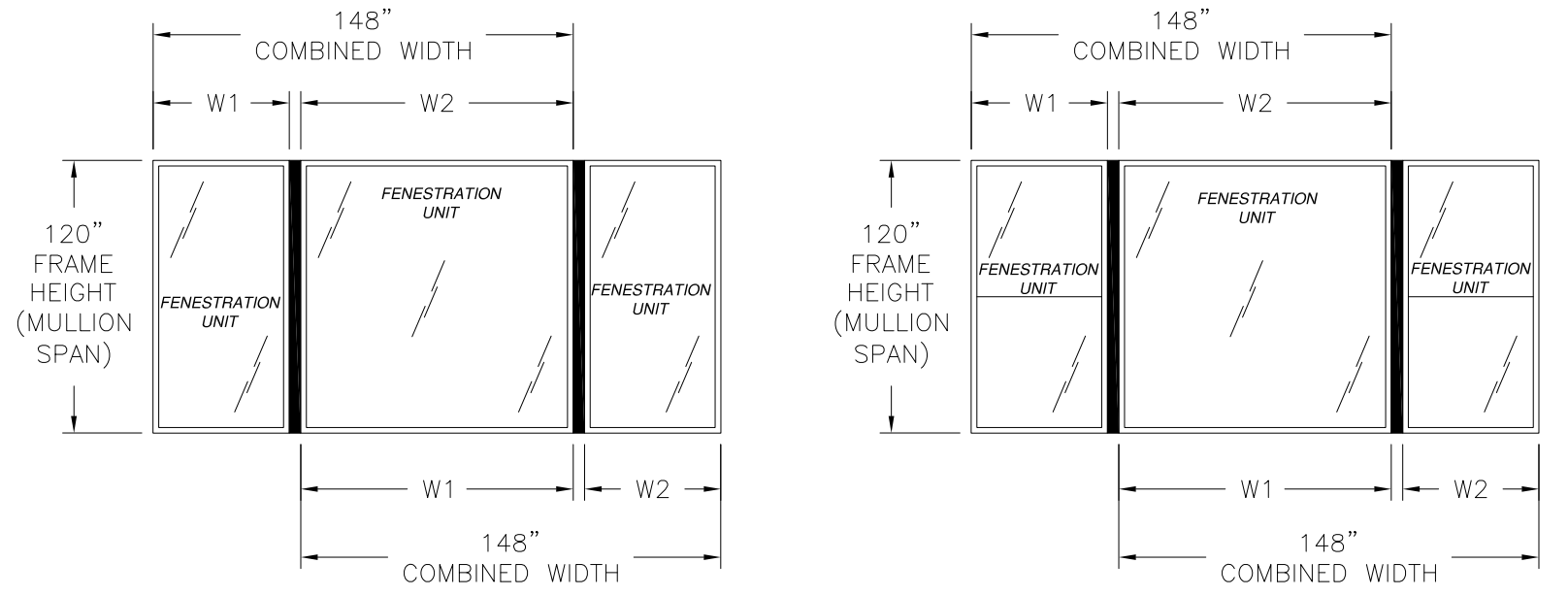
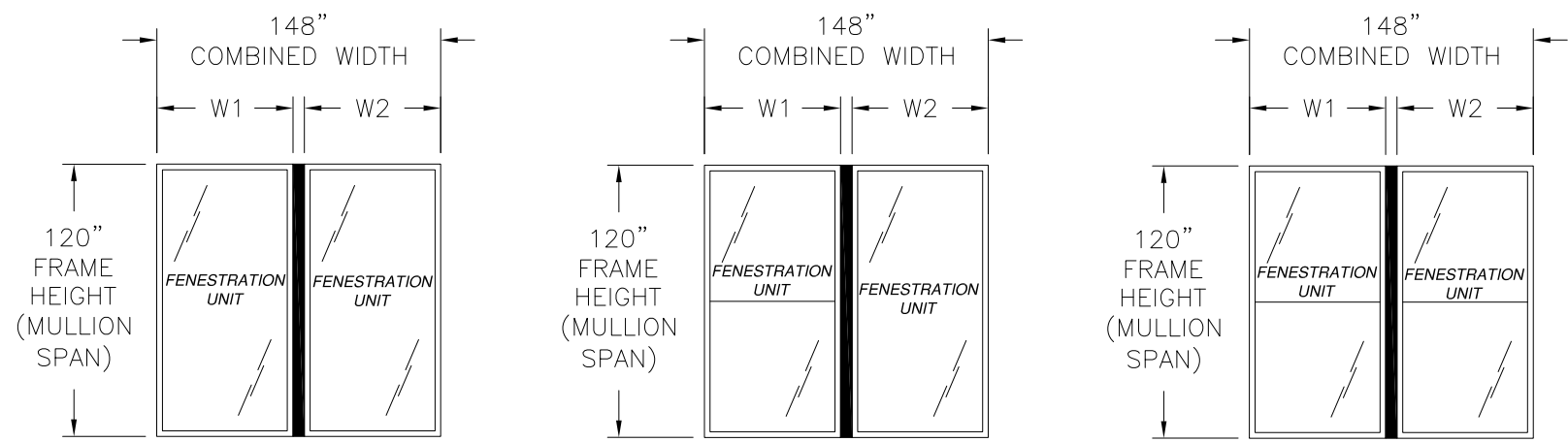

APPROVED CONFIGURATIONS

TWIN AND TRIPLE UNITS ARE SHOWN UNLIMITED NUMBER OF UNITS MAY BE MULLED TOGETHER AS LONG AS UNIT SIZES DO NOT EXCEED SIZES SHOWN HEREIN AND MULLION IS ANCHORED AS SHOWN IN INSTALLATION DETAILS

DESIGN PRESSURE TABLE INSTRUCTIONS:

1. DEFINE REQUIRED DESIGN LOAD PER BUILDING CODE CHAPTER 16.
2. DETERMINE TRIBUTARY WIDTH AND MULLION SPAN BASED ON PRODUCT TO BE INSTALLED. SEE FORMULA FOR TRIBUTARY WIDTH.
3. LOCATE MULLION SPAN (UNIT HEIGHT) AND TRIBUTARY WIDTH. AT THE INTERSECTION OF ROW AND COLUMN CONTAINING THE MULLION SPAN AND TRIBUTARY WIDTH RESPECTIVELY IS THE MULLION RATING FOR PRODUCT IN STEP 2. MULLION RATING MUST BE EQUAL OR GREATER THAN REQUIRED DESIGN PRESSURE OBTAINED IN STEP 1.

$$\text{TRIBUTARY WIDTH} = \frac{W1 + W2}{2}$$

Mullion span (in)	Design pressure rating (psf)								
	Tributary width (in)								
	24.00	30.00	36.00	42.00	48.00	54.00	60.00	66.00	72.00
60.00	200.0	200.0	200.0	200.0	200.0	200.0	200.0	200.0	200.0
66.00	200.0	200.0	200.0	200.0	200.0	200.0	200.0	200.0	200.0
72.00	200.0	200.0	200.0	200.0	198.0	187.7	181.0	177.2	176.0
78.00	200.0	200.0	200.0	190.6	176.0	165.6	158.4	153.6	150.9
84.00	200.0	200.0	192.0	172.4	158.4	148.2	140.8	135.5	132.0
90.00	200.0	200.0	176.0	157.4	144.0	134.1	126.7	121.3	117.3
96.00	200.0	187.7	162.5	144.8	132.0	122.4	115.2	109.7	105.6
102.00	200.0	174.8	150.9	134.1	121.1	110.4	102.1	95.8	91.0
108.00	190.1	153.8	130.0	113.2	101.0	91.8	84.7	79.2	74.8
114.00	161.3	130.4	110.0	95.7	85.2	77.2	71.0	66.2	62.4
120.00	138.1	111.5	93.9	81.6	72.5	65.6	60.2	56.0	52.6

LARGE AND SMALL MISSILE IMPACT, LEVEL D, WIND ZONE 3

SIGNED: 07/15/2013

WinDoor
INCORPORATED

7500 AMSTERDAM DRIVE
ORLANDO, FL 32832
Phone: 407.481.8400
Fax: 407.481.0505
www.windoorinc.com

4"x4"x1/4" TUBE MULLION
VERTICAL IMPACT
CONFIGURATIONS & DP CHART

DRAWN: V.L. DWG NO. 08-01691 REV -

SCALE NTS DATE 07/23/12 SHEET 2 OF 4

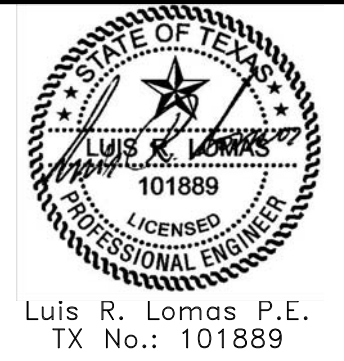

Luis R. Lomas P.E.
TX No.: 101889

REVISIONS			
REV	DESCRIPTION	DATE	APPROVED

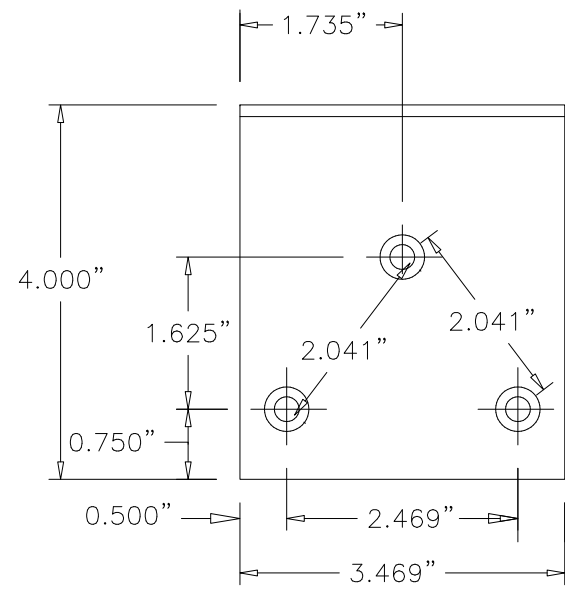

CLIP
ALUMINUM 6105-T5 .125" THICK

ALL HOLES TO BE DRILLED AND COUNTERSUNK FOR A 1/4" DIAMETER FLAT HEAD SCREW

#10 SELF DRILLING SCREW
LOCATED 6" FROM EACH END
AND 24" MAX O.C.
SEE NOTES 4 & 5 SHEET 1

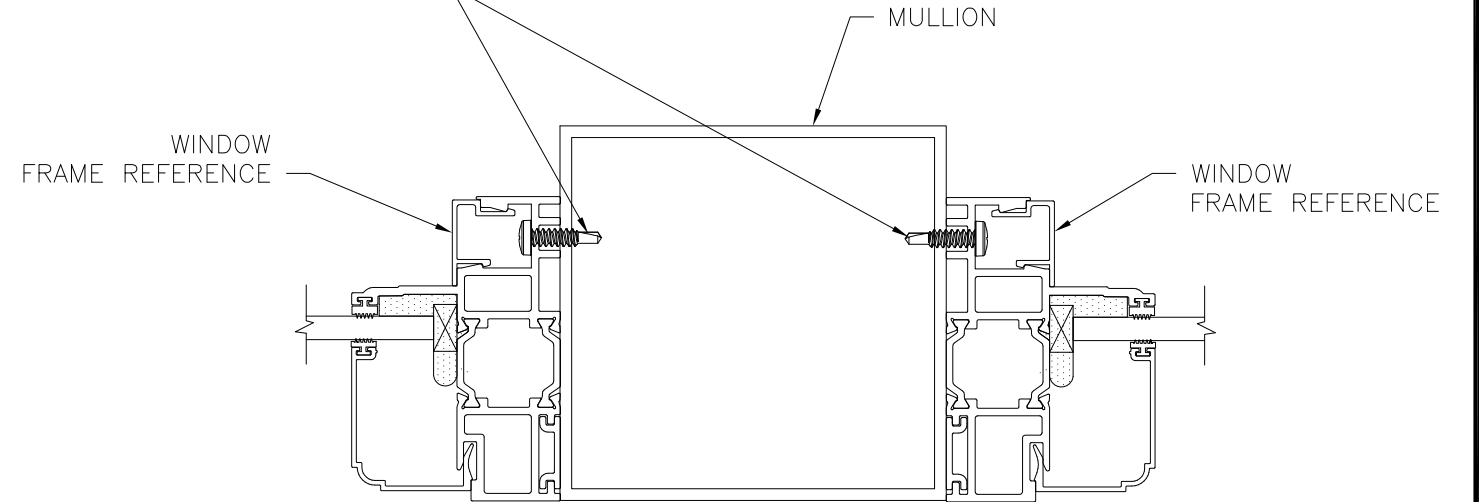

WINDOW/MULLION
CONNECTION DETAIL

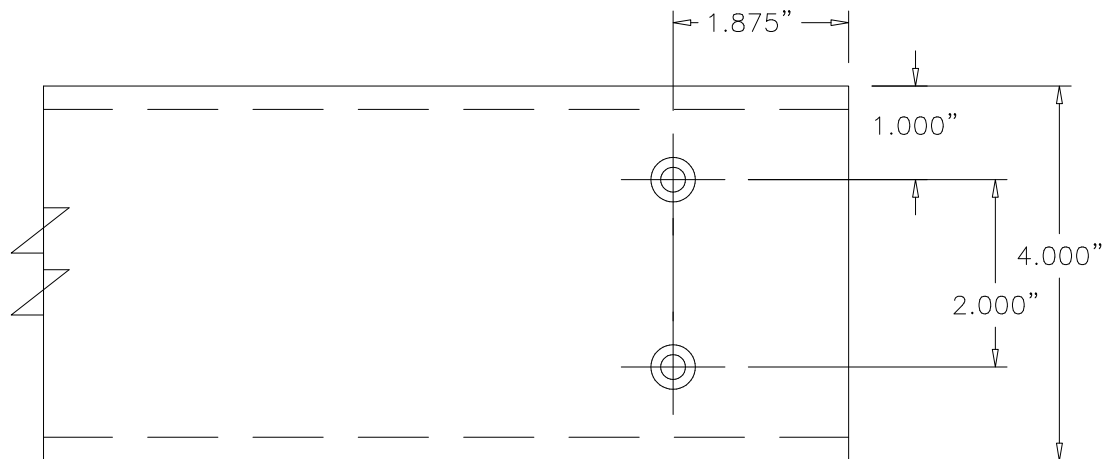

MULLION
ALUMINUM 6063-T6 .25" THICK

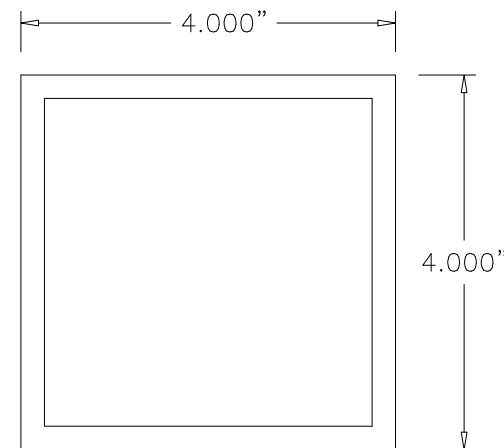

SIGNED: 07/15/2013

WinDoor INCORPORATED		7500 AMSTERDAM DRIVE ORLANDO, FL 32832 Phone: 407.481.8400 Fax: 407.481.0505 www.windoorinc.com	
4"x4"x1/4" TUBE MULLION VERTICAL IMPACT COMPONENTS			
DRAWN: V.L.	DWG. NO. 08-01691	REV -	
SCALE NTS	DATE 07/23/12	SHEET 4 OF 4	



Luis R. Lomas P.E.
TX No.: 101889