

NOTES:
 1. IMPACT RESISTANT GLAZING OPTION - IMPACT RESISTANT GLAZING SYSTEM MAY BE INSTALLED IN TOP OR INTERMEDIATE SECTION (WITH OR WITHOUT DECORATIVE INSERTS). GLAZING SHALL BE 1/4" POLYCARBONATE. MAXIMUM GLAZING DIMENSIONS SHALL BE 14" x 46" CUTOUT, FASTENED WITH A MINIMUM #8 X 1" SMS: 3X ALONG THE HORIZONTAL AND 3X ALONG THE VERTICAL. SEE DETAIL E ON SHEET 2 FOR ASSEMBLY DETAILS.

2. NON-IMPACT RESISTANT GLAZING OPTION - .090" MINIMUM SSB GLAZING IN MOLDED FRAMES SCREWED TOGETHER WITH A MINIMUM OF (10) #8x1" SCREWS (3X ALONG THE HORIZONTAL AND 2X ALONG THE VERTICAL) INSTALLED IN TOP OR INTERMEDIATE SECTION (WITH OR WITHOUT DECORATIVE INSERTS) MEETS UNIFORM STATIC WIND PRESSURES SHOWN ON THIS DRAWING. MAXIMUM GLAZING DIMENSIONS SHALL BE 15" x 46" CUTOUT. GLAZING IS NOT IMPACT RESISTANT AND DOES NOT MEET THE REQUIREMENTS FOR WIND-BORNE DEBRIS REGIONS.

3. VINYL OR WOOD DOOR STOP NAILED A MAXIMUM OF 6" O.C. MUST OVERLAP TOP AND BOTH ENDS OF PANELS MINIMUM 7/16" TO MEET NEGATIVE PRESSURES.

4. KEY LOCK, SLIDE LOCKS, OR OPERATOR REQUIRED.

5. LOUVER OPTION - .040" MINIMUM LOUVERS IN MOLDED FRAMES SCREWED TOGETHER WITH A MINIMUM OF (10) #8x1" SCREWS (3X ALONG THE HORIZONTAL AND 2X ALONG THE VERTICAL) INSTALLED IN THE BOTTOM SECTION. MAXIMUM LOUVER DIMENSIONS SHALL BE 15" x 19" CUTOUT. LOUVERS ARE NOT IMPACT RESISTANT AND DO NOT MEET THE REQUIREMENTS FOR WIND-BORNE DEBRIS REGIONS..

6. FACER STEEL TO HAVE A MINIMUM 27 GA THICKNESS AND BACKER STEEL TO HAVE A MINIMUM 29 GA THICKNESS.

7. A 4-1/2" x 6" x 22 GA BACKER PLATE IS TO BE LOCATED AT EVERY INTERMEDIATE AND OUTER END HINGE LOCATION.

8. THE DESIGN OF THE SUPPORTING STRUCTURAL ELEMENTS SHALL BE THE RESPONSIBILITY OF THE PROFESSIONAL OF RECORD FOR THE BUILDING OR STRUCTURE AND IN ACCORDANCE WITH CURRENT BUILDING CODES FOR THE LOADS LISTED ON THIS DRAWING.

9. DOOR JAMB TO BE MINIMUM 2x4 STRUCTURAL GRADE LUMBER. REFER TO JAMB CONNECTION SUPPLEMENT FOR ATTACHMENT TO SUPPORTING STRUCTURE.

10. FOR LOW HEAD ROOM LIFT CONDITIONS, TOP BRACKET SHALL BE A 13 GA LHR 7/4 TOP BRACKET WITHOUT PUCHNUTS AND WITH A MINIMUM OF (3) 1/4-14x7/8" SELF DRILLING CRIMP TITE SCREWS IN LIEU OF THE BRACKET SHOWN ON THIS DRAWING. U-BAR ON TOP SECTION SHALL BE INSTALLED ON TOP OF LHR TOP BRACKETS.

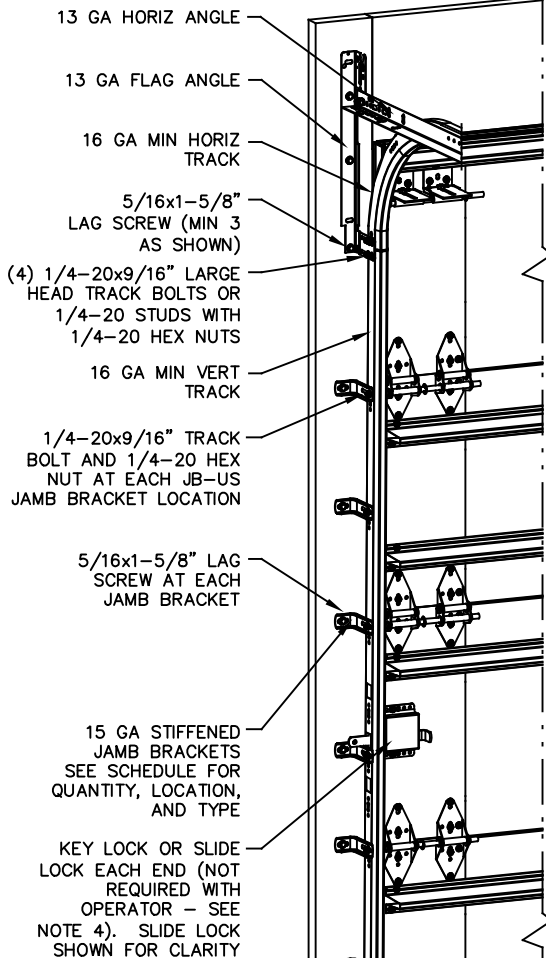

NOTE: (4) SECTION SOLID DOOR SHOWN. SEE NOTES 1 & 2 THIS SHEET FOR GLAZING OPTIONS.

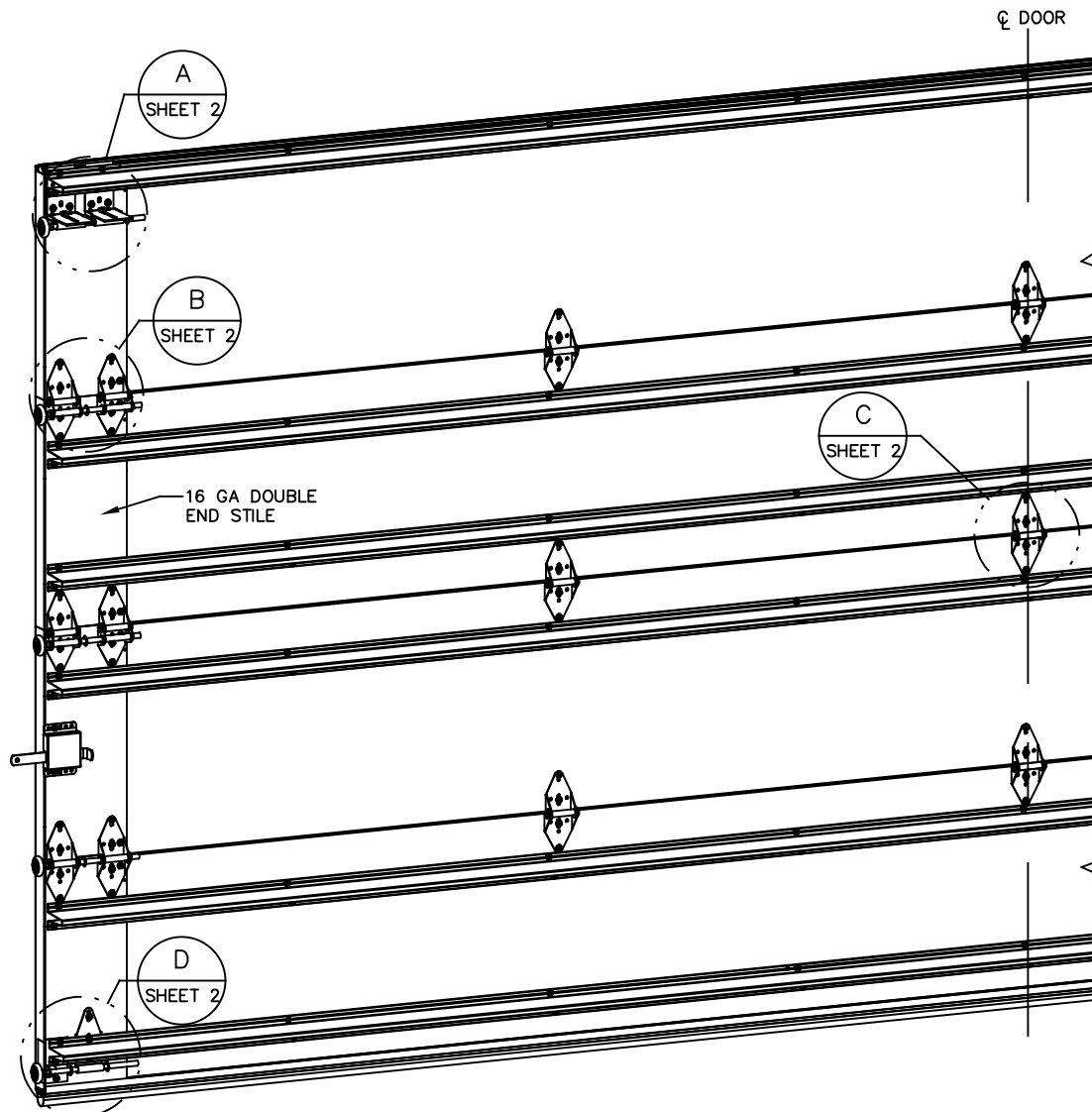

SUPERIMPOSED DESIGN PRESSURE LOADS ON SUPPORTING STRUCTURE

DOOR WIDTH	DOOR HEIGHT	UNIFORM LOAD EACH JAMB (PLF)
10'-2"	ALL	+152.5/-170.3
12'-2"	ALL	+182.5/-203.8
14'-2"	ALL	+212.5/-237.3
15'-2"	ALL	+227.5/-254.0
16'-2"	ALL	+242.5/-270.8

JAMB BRACKET SCHEDULE

DOOR HEIGHT	NO. OF SECTIONS	NO. OF JAMB BRACKETS (EACH JAMB)	LOCATION OF CENTERLINE OF JAMB BRACKETS MEASURED FROM BOTTOM OF TRACK (ALL DIMENSIONS ± 2")
6'-6"	4	7	2" (JB-US), 10" (JB-US), 21-3/4" (JB-US), 29-3/4" (JB-US), 39" (JB-US), 48" (JB-US), 57-1/4" (JB-US)
7'-0"	4	7	2" (JB-US), 10" (JB-US), 21-3/4" (JB-US), 29-3/4" (JB-US), 42" (JB-US), 52-1/2" (JB-US), 63-1/4" (JB-US)
7'-6"	4 OR 5	8	2" (JB-US), 10" (JB-US), 18-3/4" (JB-US), 26-3/4" (JB-US), 36" (JB-US), 45" (JB-US), 54-1/4" (JB-US), 74-1/2" (JB-US)
8'-0"	4 OR 5	8	2" (JB-US), 10" (JB-US), 21-3/4" (JB-US), 29-3/4" (JB-US), 39" (JB-US), 48" (JB-US), 57-1/2" (JB-US), 75-1/2" (JB-US)
> 8'-0"			SEE NOTE BELOW

NOTE: (JB-US) FOLLOWING DIMENSION DENOTES SLOTTED JAMB BRACKET ATTACHED TO TRACK WITH 1/4-20x9/16" TRACK BOLT AND NUT AS SHOWN ABOVE.

ALL DOORS GREATER THAN 8' IN HEIGHT REQUIRE USE OF CONTINUOUS WALL ANGLE. SEE SUPPLEMENT TRACK CHART FOR DETAILS.

THE DOORS ARE DESIGNED AND MANUFACTURED TO COMPLY WITH THE 2018 IRC AND THE 2018 IBC.

REVISIONS				
ER	REV	DESCRIPTION	DATE	APPROVAL
	C	REV TITLE BLOCK	10/2/2017	ESC
32177	D	ADD MODEL# 7655	11/15/2019	TLC
32442	E	ADDED NYLON ROLLER OPT	8/2/2020	TLC
32442	F	ADDED IRC/IBC NOTE	8/19/2020	TLC

STATIC PRESSURE RATINGS	APPROVED SIZES
DESIGN PRESSURE(PSF): +30.0/-33.5	MAX WIDTH: 16'-2"
IMPACT/CYCLIC RATED: YES	MAX HEIGHT: 24'
	MAX SECTION HEIGHT: 24'

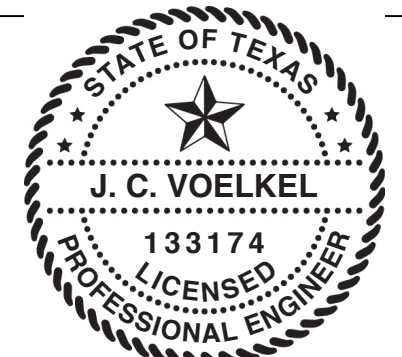

J. CHRISTIAN VOELKEL, PE
 312 N. NEW WARRINGTON RD, UNIT 1A
 PENSACOLA, FL
 FL PE 82229
 TX PE 133174

PROFESSIONAL ENGINEER'S SEAL PROVIDED ONLY FOR VERIFICATION OF WIND LOAD CONSTRUCTION DETAILS.

THE DRAWINGS AND ALL OTHER INFORMATION CONTAINED HEREIN ARE THE CONFIDENTIAL AND PROPRIETARY PROPERTY OF OVERHEAD DOOR CORPORATION AND ITS AFFILIATED COMPANIES. THIS DRAWING AND INFORMATION, IN WHOLE OR IN PART, MAY NOT BE COPIED IN ANY MANNER OR DISCLOSED TO ANYONE WITHOUT THE PRIOR WRITTEN CONSENT OF OVERHEAD DOOR CORPORATION. NO DISCLOSURE OF ANY OF THIS DRAWING OR INFORMATION IS INTENDED TO OPERATE AS A LICENSE OR AUTHORIZATION TO USE IT FOR ANY PURPOSE WITHOUT THE SPECIFIC WRITTEN CONSENT OF OVERHEAD DOOR CORPORATION.									
REF DWG	USED ON	TOLERANCES UNLESS OTHERWISE SPECIFIED		FINISH		The Genuine. The Original.		DRAWING TITLE:	
		HOLE DIAMETER	WHOLE NUMBERS: ± .25	N/A		LEWISVILLE, TEXAS		SERIES 5745/5765/7565	
		.251 TO .500 +.004/-0.003	.X ± .1	UNIT OF MEASURE		DRAWN BY:		7655/515/525	
		.500 TO .750 +.006/-0.003	.XX ± .03	EACH		G. TAYLOR		DATE: 10/25/13	
		.750 TO 1.000 +.008/-0.003	.XXX ± .010	MATERIAL:		CHECKED BY:		DRAWING NUMBER: D-411323	
		FRACTIONS ± 1/16	ANGLES: ± .5°	NONE		APPROVED BY:		SCALE: N.T.S. SHEET 1 OF 2	

REVISIONS				
REV	DESCRIPTION	DATE	APPROVAL	
C	REV TITLE BLOCK	10/2/2017	ESC	
D	ADD MODEL# 7655	11/15/2019	TLC	
E	ADDED NYLON ROLLER OPT	8/2/2020	TLC	
F	ADDED IRC/IBC NOTE	8/19/2020	TLC	

(2) 12 GA COMMERCIAL 'L' FRAME TOP BRACKETS ATTACHED WITH (4) 1/4-20x7/8" SELF DRILLING SCREWS (2 THROUGH STRUT AND TOP BRACKET)

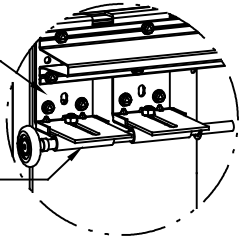

13 GA ROLLER SLIDE ATTACHED TO BRACKET WITH 5/16-18 BOLT & NUT IN THE CENTER SLOT

ADD (2) 1/4-14x7/8" SELF DRILLING CRIMPITE SCREWS (INSIDE OF EACH INSIDE END HINGE)

DETAIL A

2" STEEL ROLLER WITH 9" GRADE 1144 OR EQUIVALENT STEM AND 7/16" PUSH NUT AT EACH ROLLER LOCATION LOCATED BETWEEN THE BRACKET OR HINGE (EXCEPT PUCHNUT LOCATED ON THE TOP AND BOTTOM ROLLER IS LOACED OUTSIDE OF BOTH BRACKETS). 1/4" MAX BETWEEN PUSH NUT AND OUTER HINGE. OPTIONAL NYLON, 10/11-BALL BEARING ROLLER AVAILABLE.

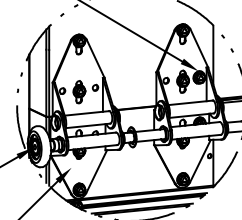

DETAIL B

(2) 14 GA WIDE BODY END HINGES EACH ATTACHED WITH (4) 1/4-14x7/8" SELF DRILLING CRIMPITE SCREWS

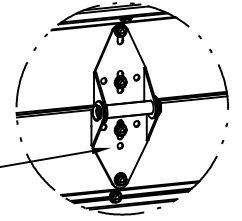

DETAIL C

14 GA WIDE BODY INTERMEDIATE HINGE ATTACHED WITH (4) 1/4-14x7/8" SELF DRILLING CRIMPITE SCREWS

12 GA EXTENSION BRACKET ATTACHED WITH (3) 1/4-14x7/8" SELF DRILLING CRIMPITE SCREWS (2 THROUGH STRUT AND BRACKET)

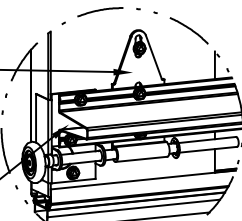

DETAIL D

14 GA BOTTOM BRACKET ATTACHED WITH (2) 1/4-14x7/8" SELF DRILLING CRIMPITE SCREWS THROUGH STRUT AND BOTTOM BRACKET AND (1) 1/4-14x5/8" SELF DRILLING TAMPER RESISTANT SCREW

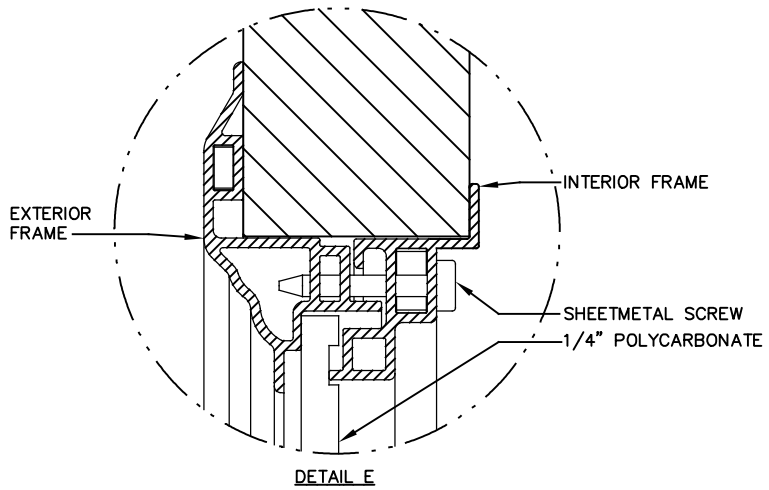
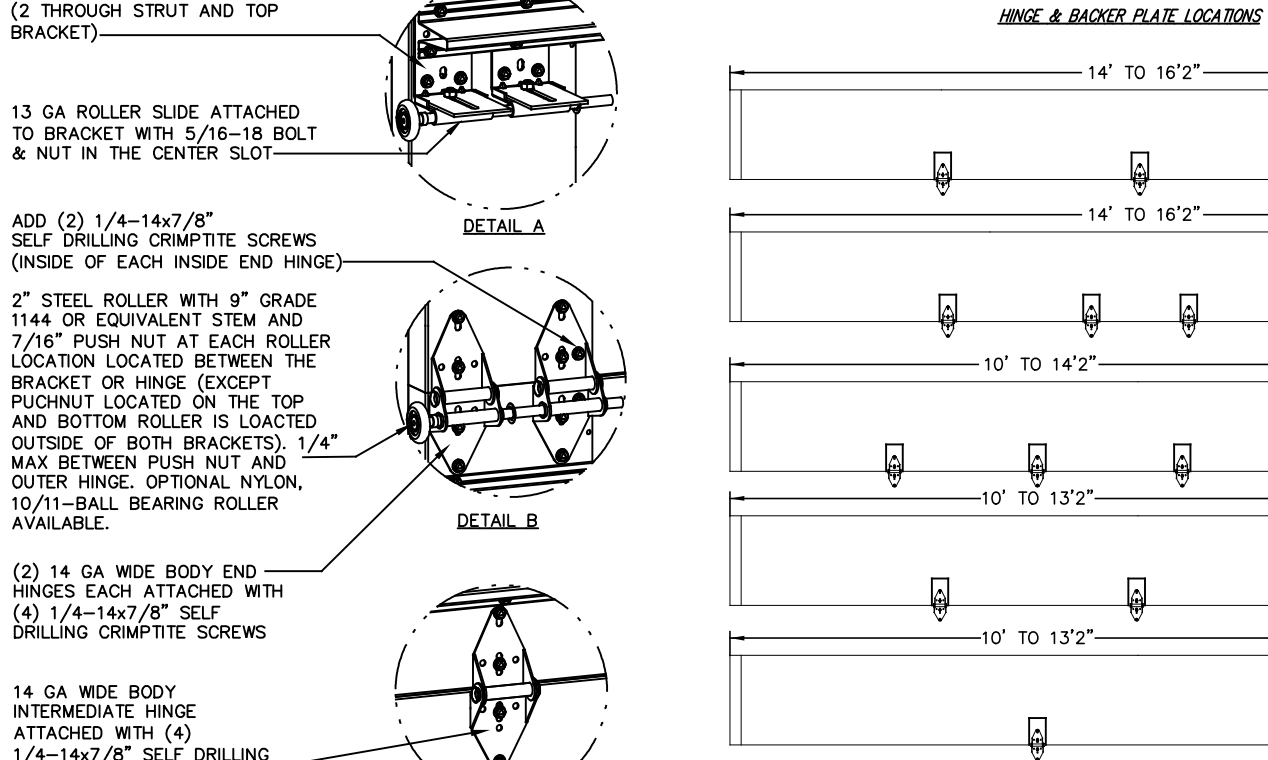

ALL U-BARS SHALL BE ATTACHED WITH (2) 1/4-14x7/8" SELF DRILLING CRIMPITE SCREWS AT EACH HINGE LOCATION AND BETWEEN ALL END HINGES AND INTERMEDIATE HINGES. A MINIMUM OF (14) FASTENERS ARE TO BE USED.

(4) SECTION DOORS WITH (6) 3" 18 GA 80 KSI U-BARS LOCATED AS SHOWN

(5) SECTION DOORS WITH (8) 3" 18 GA 80 KSI U-BARS LOCATED AS SHOWN

(6) SECTION DOORS WITH (9) 3" 18 GA 80 KSI U-BARS LOCATED AS SHOWN

(7) SECTION DOORS WITH (11) 3" 18 GA 80 KSI U-BARS LOCATED AS SHOWN

(8) SECTION DOORS WITH (12) 3" 18 GA 80 KSI U-BARS LOCATED AS SHOWN

(9) SECTION DOORS WITH (14) 3" 18 GA 80 KSI U-BARS LOCATED AS SHOWN

(10) SECTION DOORS WITH (15) 3" 18 GA 80 KSI U-BARS LOCATED AS SHOWN

THE DOORS ARE DESIGNED AND MANUFACTURED TO COMPLY WITH THE 2018 IRC AND THE 2018 IBC.

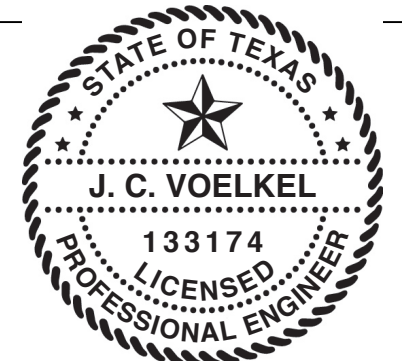

J. CHRISTIAN VOELKEL, PE
312 N. NEW WARRINGTON RD, UNIT 1A
PENSACOLA, FL
FL PE 82229
TX PE 133174

PROFESSIONAL ENGINEER'S SEAL PROVIDED ONLY FOR VERIFICATION OF WIND LOAD CONSTRUCTION DETAILS.

THE DRAWINGS AND ALL OTHER INFORMATION CONTAINED HEREIN ARE THE CONFIDENTIAL AND PROPRIETARY PROPERTY OF OVERHEAD DOOR CORPORATION AND ITS AFFILIATED COMPANIES. THIS DRAWING AND INFORMATION, IN WHOLE OR IN PART, MAY NOT BE COPIED IN ANY MANNER OR DISCLOSED TO ANYONE WITHOUT THE PRIOR WRITTEN CONSENT OF OVERHEAD DOOR CORPORATION. NO DISCLOSURE OF ANY OF THIS DRAWING OR INFORMATION IS INTENDED TO OPERATE AS A LICENSE OR AUTHORIZATION TO USE IT FOR ANY PURPOSE WITHOUT THE SPECIFIC WRITTEN CONSENT OF OVERHEAD DOOR CORPORATION.									
REF DWG		USED ON		TOLERANCES UNLESS OTHERWISE SPECIFIED		FINISH		DATE	
				HOLE DIAMETER		N/A		10/25/13	
				UNDER .251 +.004/-0.003		WHOLE NUMBERS: ± .25		DRAWING TITLE:	
				.251 TO .500 +.006/-0.003		.X ± .1		SERIES 5745/5765/7565	
				OVER .500 +.008/-0.003		.XX ± .03		7655/515/525	
				FRACTIONS		.XXX ± .010		DRAWING NUMBER	
				± 1/16		ANGLES: ± .5°		D-411323	
						UNIT OF MEASURE		SCALE: N.T.S.	
						EACH		SHEET 2 OF 2	