

NOTES:

- NON IMPACT GLAZING OPTIONS:**
16 X 9.75 CLEAR OPENING
GLAZING SSB (0.090") MINIMUM.
MAY INCLUDE DECORATIVE INSERTS
INSTALLED IN TOP OR INTERMEDIATE SECTION.
NOT AVAILABLE IN MORE THAN ONE SECTION.
DOES NOT SATISFY WINDBORNE-DEBRIS.
- IMPACT GLAZING OPTION:**
16.75 X 9.75 CLEAR OPENING
GLAZING 1/4" GROOVED POLYCARBONATE
ALUMINUM FRAMES WITH 10 SCREWS MAY
INCLUDE DECORATIVE INSERTS INSTALLED IN
TOP OR INTERMEDIATE SECTION.
NOT AVAILABLE IN MORE THAN ONE SECTION.
SEE ASSEMBLY DETAIL ON SHEET 2.
- VINYL OR WOOD DOOR STOP NAILED A
MAXIMUM OF 6" O.C. MUST OVERLAP TOP AND
BOTH ENDS OF PANELS MINIMUM 7/16" TO
MEET NEGATIVE PRESSURES.**
- KEY LOCK, SLIDE LOCK, OR OPERATOR
REQUIRED.**
- LOUVER OPTION - .032" MINIMUM LOUVERS
IN MOLDED FRAMES SCREWED TOGETHER WITH
A MINIMUM OF (10) #8x1" SCREWS INSTALLED
IN THE BOTTOM SECTION. LOUVERS ARE NOT
IMPACT RESISTANT AND DO NOT MEET THE
REQUIREMENTS FOR WIND-BORNE DEBRIS
REGIONS.**
- SECTION STEEL TO HAVE A MINIMUM 25 GA
THICKNESS.**
- THE DESIGN OF THE SUPPORTING
STRUCTURAL ELEMENTS SHALL BE THE
RESPONSIBILITY OF THE PROFESSIONAL OF
RECORD FOR THE BUILDING OR STRUCTURE
AND IN ACCORDANCE WITH CURRENT BUILDING
CODES FOR THE LOADS LISTED ON THIS
DRAWING.**
- DOOR JAMB TO BE GRADE 2 SOUTHERN
PINE. REFER TO JAMB CONNECTION
SUPPLEMENT FOR ATTACHMENT TO
SUPPORTING STRUCTURE.**
- FOR LOW HEAD ROOM LIFT CONDITIONS, TOP
BRACKET SHALL BE A 13 GA LHR 7/4 TOP
BRACKET WITH A MINIMUM OF (3)
1/4-14x7/8" SELF DRILLING CRIMPITITE
SCREWS IN LIEU OF THE BRACKET SHOWN ON
THIS DRAWING. U-BAR ON TOP SECTION SHALL
BE INSTALLED ON TOP OF LHR TOP BRACKETS.**

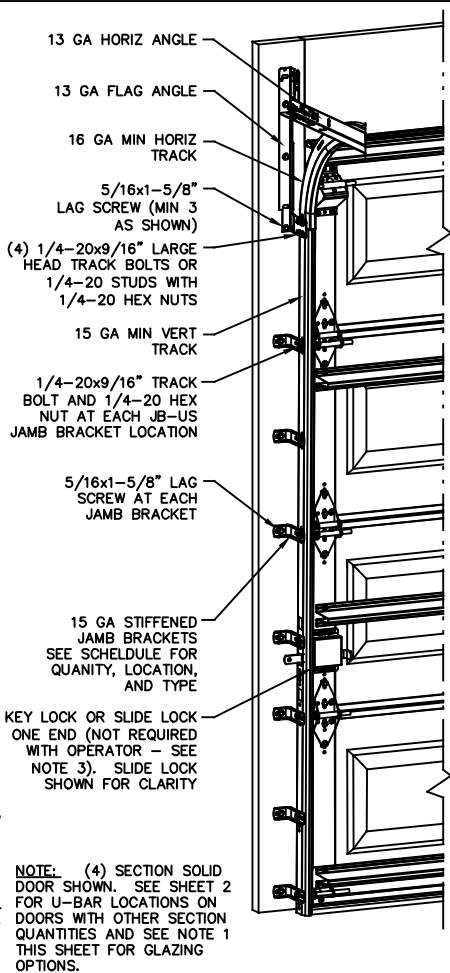

- 12 GA ROLLER SLIDE ATTACHED TO BRACKET WITH 5/16-18 BOLT & NUT IN CENTER SLOT AND 1/4-20x9/16" TRACK BOLT & 1/4-20 HEX NUT THROUGH ANY TWO ALIGNING HOLES
- 12 GA COMMERCIAL 'A' FRAME TOP BRACKET ATTACHED WITH (4) 1/4-14x7/8" SELF DRILLING CRIMPITITE SCREWS
- ADD (2) 1/4-14x7/8" SELF DRILLING CRIMPITITE SCREWS (INSIDE OF EACH END HINGE)
- 2" NYLON STORMGARD ROLLER WITH 4-1/2" STEM EACH ROLLER LOCATION. OPTIONAL- 11 BALL BEARING NYLON ROLLER
- #1 HINGE IS 14 GA
#2 HINGE IS 13 GA
#3 HINGE (AND ALL ABOVE) ARE 13 GA HINGE ATTACHED WITH (4) 1/4-14x5/8" SELF TAPPING SCREWS
- 18 GA NARROW BODY INTERMEDIATE HINGE ATTACHED WITH (4) 1/4-14x5/8" SELF TAPPING SCREWS
- 14 GA BOTTOM BRACKET ATTACHED WITH (2) 1/4-14x7/8" SELF DRILLING CRIMPITITE SCREWS AND (1) 1/4-14x5/8" SELF DRILLING RED SCREW
- (1) 1/4-14x7/8" SELF DRILLING CRIMPITITE SCREWS

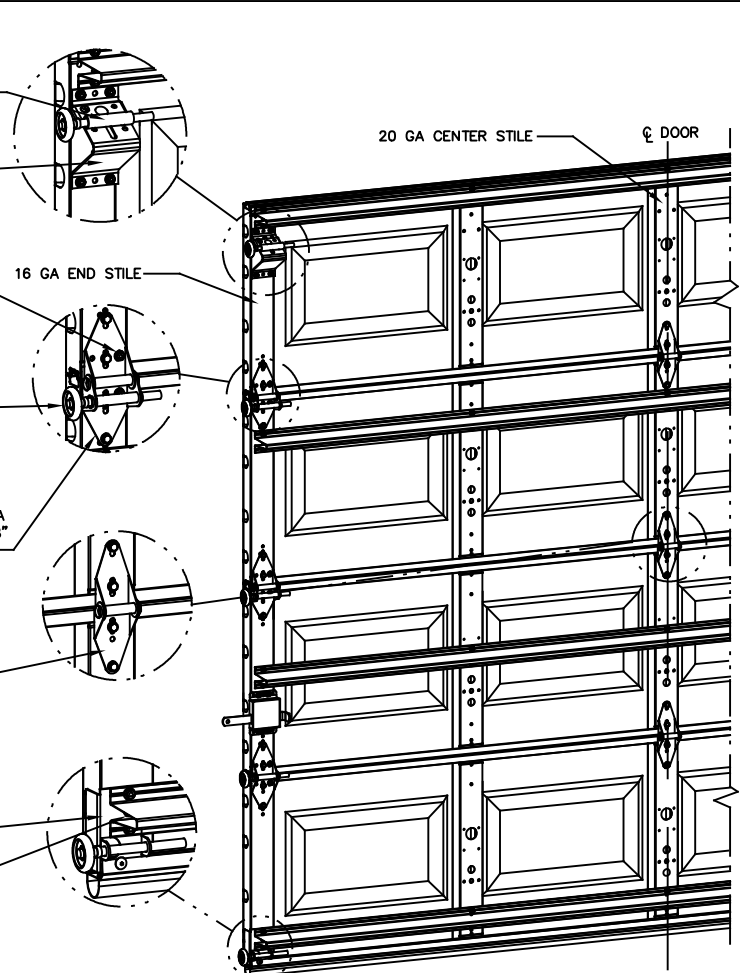

REVISIONS
PO NEW DRAWING, PER ER 31052
ESC 10/12/18
P1 UPDATED NOTES ADDED LHR DETAIL ER 31052
ESC 2/12/19
REV B ADDED IRC/IBC NOTE
TLC 4/12/21

NOTE: (4) SECTION SOLID DOOR SHOWN. SEE SHEET 2 FOR U-BAR LOCATIONS ON DOORS WITH OTHER SECTION QUANTITIES AND SEE NOTE 1 THIS SHEET FOR GLAZING OPTIONS.

JAMB BRACKET SCHEDULE			
DOOR HEIGHT	NO. OF SECTIONS	NO. OF JAMB BRACKETS (EACH JAMB)	LOCATION OF CENTERLINE OF JAMB BRACKETS MEASURED FROM BOTTOM OF TRACK (ALL DIMENSIONS ± 2")
6'-6"	4	7	2" (JB-US), 10" (JB-US), 21-3/4" (JB-US), 29-3/4" (JB-US), 39" (JB-US), 48" (JB-US), 57-1/4" (JB-US)
7'-0"	4	7	2" (JB-US), 10" (JB-US), 21-3/4" (JB-US), 29-3/4" (JB-US), 42" (JB-US), 52-1/2" (JB-US), 63-1/4" (JB-US)
7'-6"	5	8	2" (JB-US), 10" (JB-US), 18-3/4" (JB-US), 26-3/4" (JB-US), 36" (JB-US), 45" (JB-US), 54-1/4" (JB-US), 74-1/2" (JB-US)
8'-0"	5	8	2" (JB-US), 10" (JB-US), 21-3/4" (JB-US), 29-3/4" (JB-US), 39" (JB-US), 48" (JB-US), 57-1/2" (JB-US), 75-1/2" (JB-US)
> 8'-0"			SEE NOTE BELOW

NOTE: (JB-US) FOLLOWING DIMENSION DENOTES SLOTTED JAMB BRACKET ATTACHED TO TRACK WITH 1/4-20x9/16" TRACK BOLT AND NUT AS SHOWN ABOVE. ALL DOORS GREATER THAN 8' IN HEIGHT REQUIRE USE OF CONTINUOUS WALL ANGLE. SEE SUPPLEMENT TRACK CHART FOR DETAILS.

SUPERIMPOSED DESIGN PRESSURE LOADS ON SUPPORTING STRUCTURE		
DOOR WIDTH	DOOR HEIGHT	UNIFORM LOAD EACH JAMB (PLF)
8'-0"	ALL	+148.0/-164.0
9'-0"	ALL	+166.5/-184.5

COMPLIES WITH THE REQUIREMENTS OF IBC/IRC 2018.

<p>WAYNE DALTON GARAGE DOORS</p> <p>A DIVISION OF OVERHEAD DOOR CORP. 3395 ADDISON DRIVE PENSACOLA, FLORIDA 32514 (850) 474-9890</p>	STATIC PRESSURE RATINGS DESIGN (PSF): +37.00/-41.00 TEST (PSF): +55.50/-61.50 IMPACT/CYCLIC RATED (YES/NO): YES	APPROVED SIZES MAX WIDTH: 9'-0" MAX HEIGHT: 14'-0" MAX SECTION HEIGHT: 21"	SCALE: N.T.S. DATE: 10/12/18 CHECKED: 4/12/21	SIZE: A NAME: ESC TLC
	MODELS 8000/8100/8200			SHEET 1 OF 2
	WINDLOAD SPECIFICATION OPTION CODE 1108			DRAWING PART NO. 364233
				REV. B

JOHN E. SCATES, PE
2560 KING ARTHUR BLVD #124-54
LEWISVILLE, TX 75056
FL PE 51737
TX PE 56308/F2203

PROFESSIONAL ENGINEER'S SEAL PROVIDED ONLY FOR VERIFICATION OF WINDLOAD CONSTRUCTION DETAILS.

CENTER STILE & INTERMEDIATE HINGE LOCATIONS

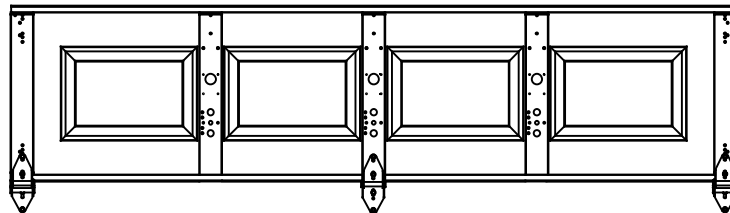

SHORT LITE GLAZING LAYOUT

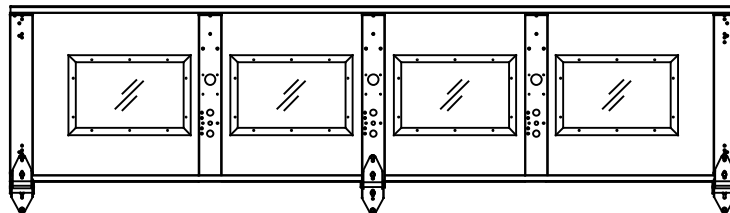

LOUVER - OPTIONAL IN BOTTOM SECTION

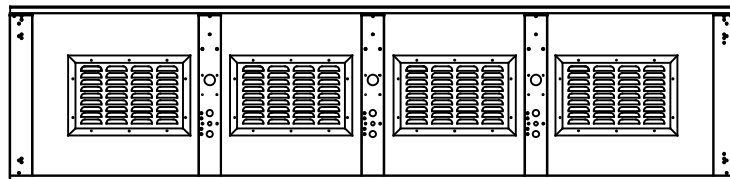

U-BAR LOCATIONS

(8) SECTION DOORS WITH
(8) 3" 20 GA 80 KSI U-BARS
LOCATED AS SHOWN

(7) SECTION DOORS WITH
(7) 3" 20 GA 80 KSI U-BARS
LOCATED AS SHOWN

(6) SECTION DOORS WITH
(6) 3" 20 GA 80 KSI U-BARS
LOCATED AS SHOWN

(5) SECTION DOORS WITH
(5) 3" 20 GA 80 KSI U-BARS
LOCATED AS SHOWN

(4) SECTION DOORS WITH
(4) 3" 20 GA 80 KSI U-BARS
LOCATED AS SHOWN

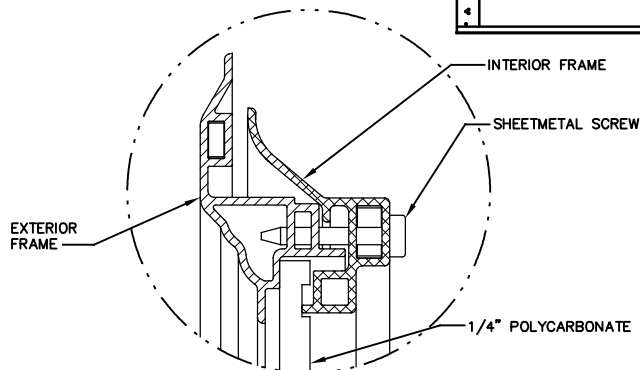

IMPACT WINDOW / ALUMINUM FRAME WITH GROOVED POLYCARBONATE (REF:NOTE 2)
DETAIL A

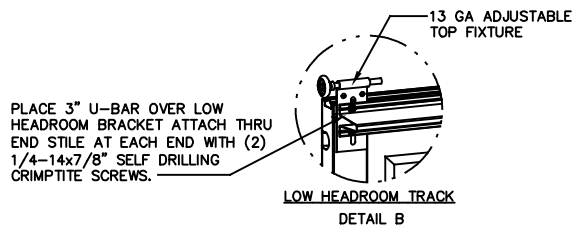

ATTACH U-BARS WITH
(2) 1/4-14x7/8\"/>

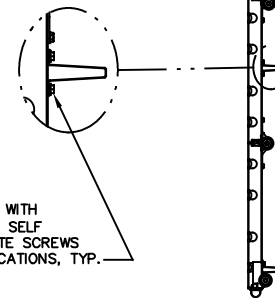

<p>WAYNE DALTON GARAGE DOORS</p> <p>A DIVISION OF OVERHEAD DOOR CORP. 3395 ADDISON DRIVE PENSACOLA, FLORIDA 32514 (850) 474-9890</p>	STATIC PRESSURE RATINGS		APPROVED SIZES	SCALE: N.T.S.	SIZE: A	
	DESIGN (PSF):	+37.00/-41.00	MAX WIDTH:	9'-0"	DATE	NAME
	TEST (PSF):	+55.50/-61.50	MAX HEIGHT:	14'-0"	DRAWN	ESC
	IMPACT/CYCLIC RATED (YES/NO):	YES	MAX SECTION HEIGHT:	21"	CHECKED	TLC
MODELS 8000/8100/8200				SHEET 2 OF 2		
WINDLOAD SPECIFICATION OPTION CODE 1108				DRAWING PART NO.	REV.	
				364233	B	

JOHN E. SCATES, PE
2560 KING ARTHUR BLVD #124-54
LEWISVILLE, TX 75056
FL PE 51737
TX PE 56308/F2203