

BRAND	MODEL
CLOPAY	904, 904U, AX, AXU
IDEAL	C4AL, C4ALU

DSB LITES OR BETTER, ANNEALED OR TEMPERED. INSULATED GLAZING SHALL CONSIST OF 2 ANNEALED OR TEMPERED DSB LITES. MAX DLO 19.325" X 25.825".

THIS PRODUCT COMPLIES WITH THE 2018 IBC/IRC.

REVISIONS					
REV. NO.	ZONE:	DATE:	ECN NO.	APPVD:	DESCRIPTION
00	-	4/7/22	*	JDW	RELEASED FOR PRODUCTION

MADE FROM 6063-T5 ALUMINUM.

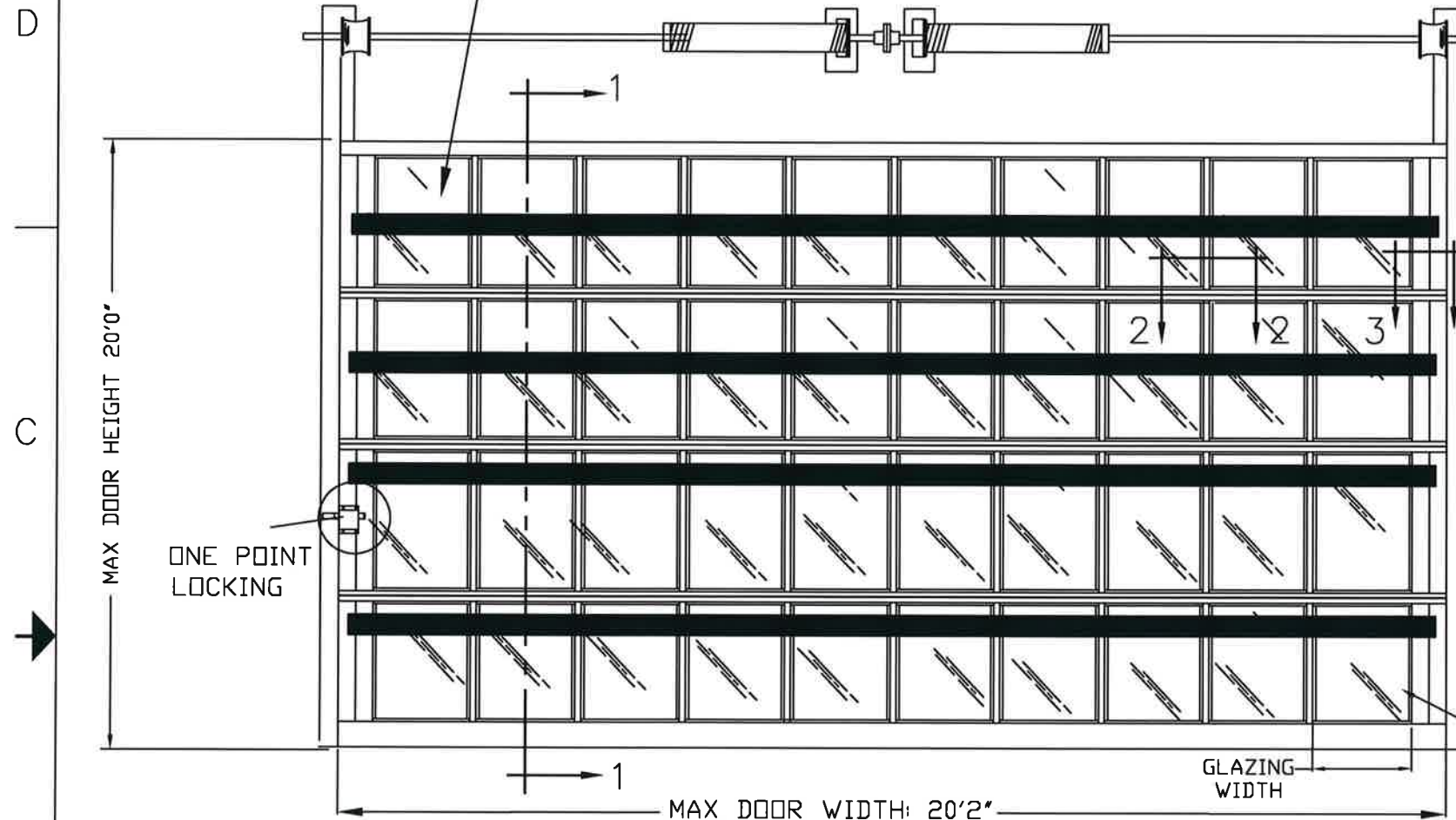

SECTION 2 - 2

CENTER STILES FASTENED TO RAILS WITH FULL LENGTH 5/16" STEEL RODS AND FLANGE NUTS.

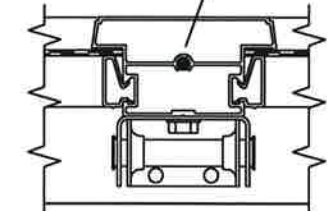

14 GAUGE CENTER HINGES ATTACHED TO INTERM. BOTTOM RAIL WITH (2) #14x5/8" SMS AND TO FIN WITH (2) 1/4"-20x1/2" HEX HEAD MACHINE SCREWS AND NUTS.

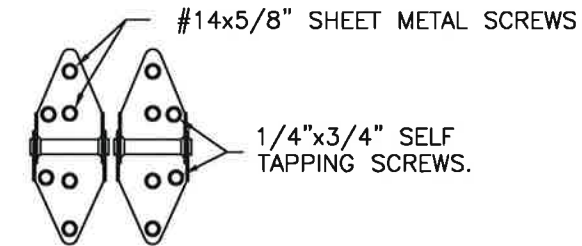

14 GA. END HINGES

EQUAL WIDTH PANELS.

SECTION 1 - 1

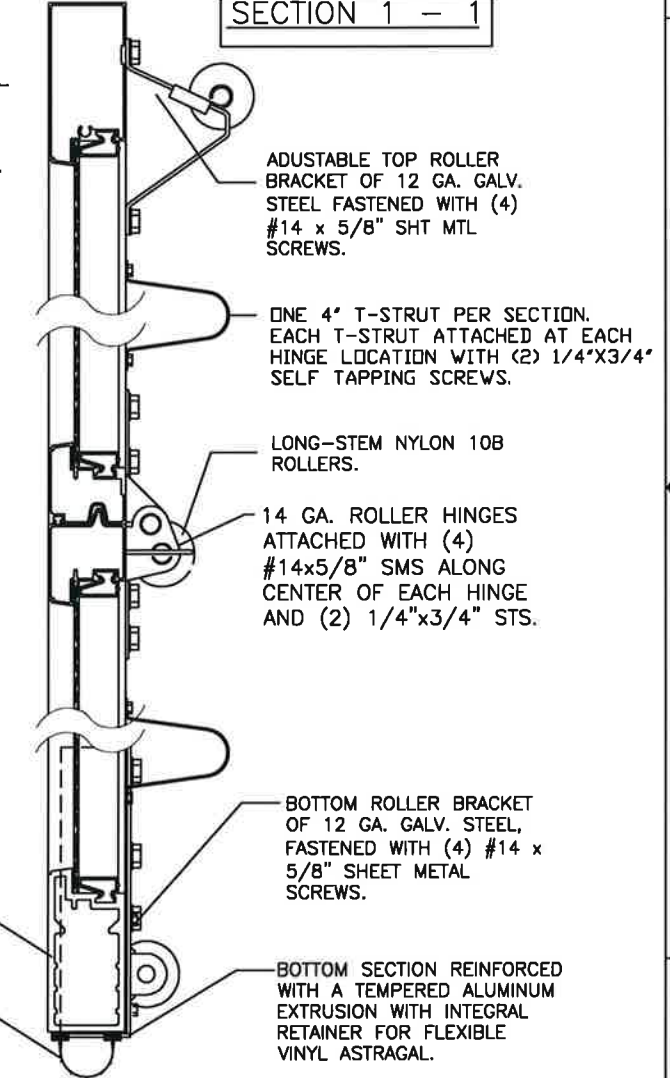

ADJUSTABLE TOP ROLLER BRACKET OF 12 GA. GALV. STEEL FASTENED WITH (4) #14 x 5/8" SHT MTL SCREWS.

ONE 4" T-STRUT PER SECTION. EACH T-STRUT ATTACHED AT EACH HINGE LOCATION WITH (2) 1/4"x3/4" SELF TAPPING SCREWS.

LONG-STEM NYLON 10B ROLLERS.

14 GA. ROLLER HINGES ATTACHED WITH (4) #14x5/8" SMS ALONG CENTER OF EACH HINGE AND (2) 1/4"x3/4" STS.

BOTTOM ROLLER BRACKET OF 12 GA. GALV. STEEL, FASTENED WITH (4) #14 x 5/8" SHEET METAL SCREWS.

BOTTOM SECTION REINFORCED WITH A TEMPERED ALUMINUM EXTRUSION WITH INTEGRAL RETAINER FOR FLEXIBLE VINYL ASTRAGAL.

SECTION 3-3

END STILES FASTENED TO RAILS WITH FULL LENGTH 5/16" STEEL RODS AND FLANGE NUTS.

REINFORCING FIN ON INTER. TOP RAILS ANGLE CUT AT END STILES.

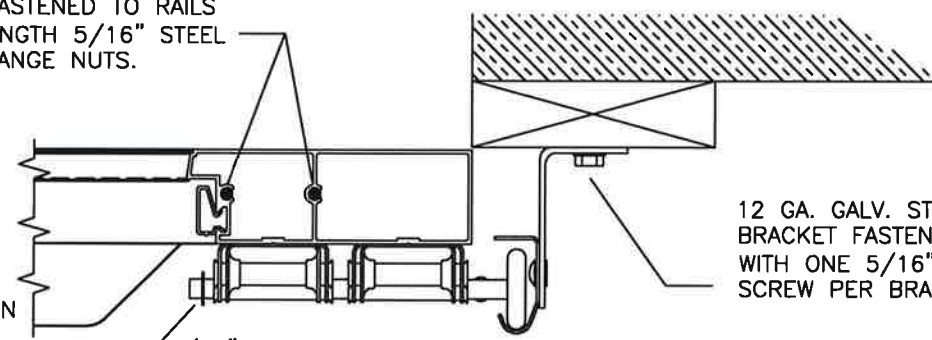

12 GA. GALV. STEEL TRACK BRACKET FASTENED TO WOOD JAMB WITH ONE 5/16"x1-5/8" WOOD LAG SCREW PER BRACKET.

7/16" PUSH-NUT, ONE PER ROLLER.

SEE PAGE 2 FOR DIFFERENT JAMB CONFIGURATIONS

DESIGN PRESSURE: +25.0, -25.0 PSF
TEST PRESSURE: +37.5, -37.5 PSF

Mark Westerfield
4/21/22
STATE OF TEXAS
MARK A. WESTERFIELD
91613
PROFESSIONAL ENGINEER

DESIGN ENGINEER:
MARK WESTERFIELD, P.E.
FLORIDA P.E. #48495
NC P.E. #23832, TEXAS P.E. #91513

MANUFACTURING PRODUCT CODE
C-AL2-1F499

NOTICE:
Confidential/Proprietary information of CLOPAY CORPORATION is contained herein and may not be disclosed, used, duplicated, made available, or distributed without its prior consent. Failure to observe this notice may result in liability for any damages and losses resulting therefrom.

Third Angle Projection

Unless Stated Otherwise TOLERANCES are

- .0 = ±.031
- .00 = ±.015
- .000 = ±.005
- .0000 = ±.001
- Degrees = ±1/2'

Unless Stated Otherwise DIMENSIONS ARE IN INCHES.

Clopay
CORPORATION

8585 Duke Boulevard
Mason, OH 45040 USA
Tel. No. 513-770-4800
Fax No. 513-770-4853

PART NO.: -
CLOPAY WINDLOAD RATING
W4

DESCRIPTION: M/N 904 20' WIDE DES. +25/-25 PSF			
DRAWN BY: J. WHEELER	DATE: 4/7/22	SCALE: NTS	DWG. SIZE B
CHECKED BY: SH	DATE: CHKD_OT	SHEET 1 OF 2	
DWG. NO.: 105633	REV. NO. 00		

4

3

2

1

2" TRACK CONFIGURATION.

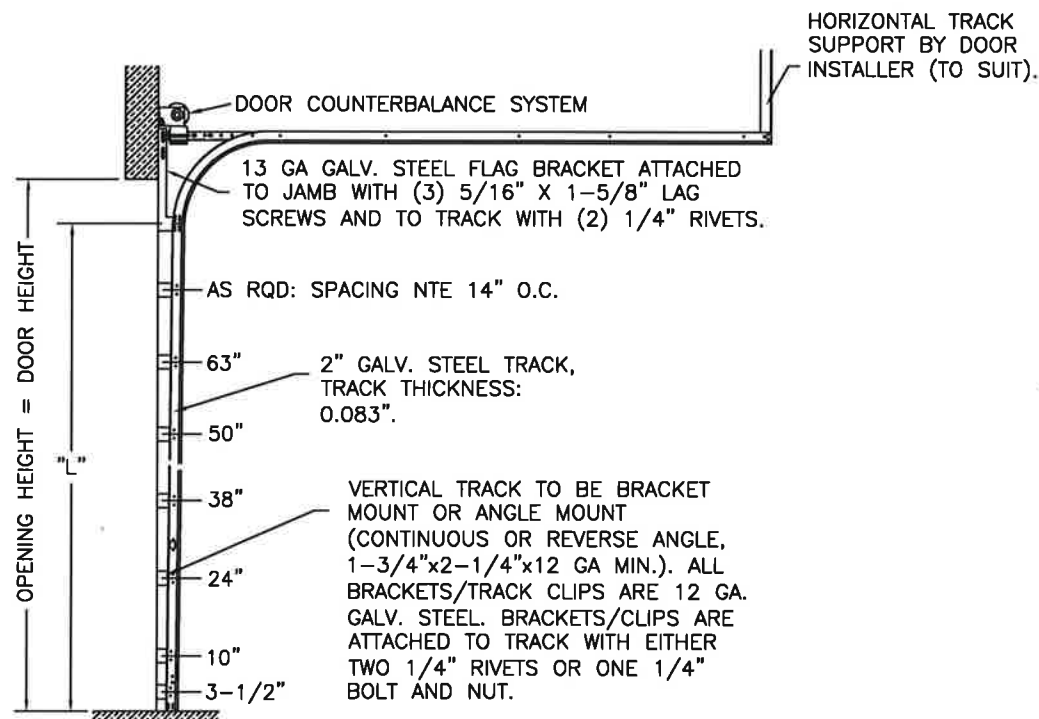

WOOD JAMBS

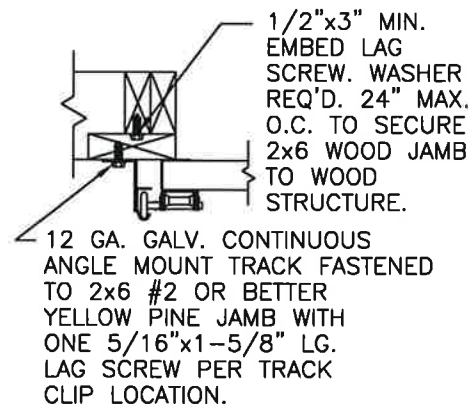

SECTION 3-3

CONCRETE JAMBS

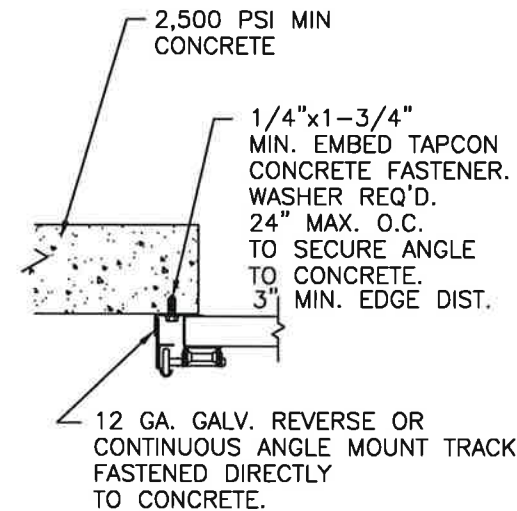

SECTION 3-3

STEEL JAMBS

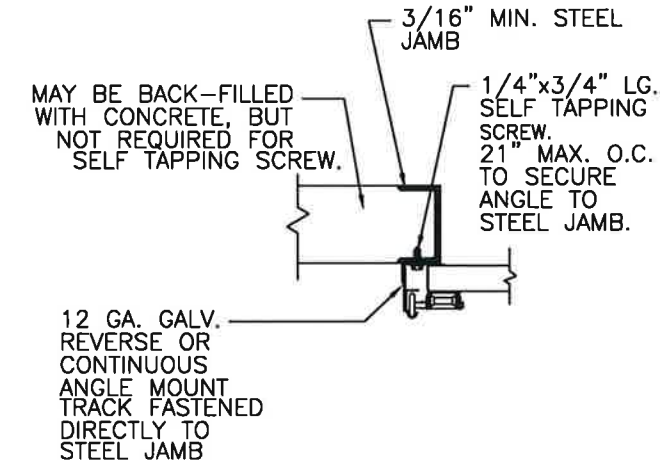

SECTION 3-3

NOTE DOUBLE TRACK HEADROOM, HI-LIFT TRACK, FOLLOW-THE-ROOF TRACK, AND VERTICAL LIFT TRACK ARE AVAILABLE OPTIONS. TRACK CONFIGURATION ABOVE THE DOOR OPENING DOES NOT AFFECT THE WIND LOAD RATING.

DOOR HEIGHT	"L"
6'-6"	70"
7'-0"	76"
7'-6"	82"
8'-0"	88"
8'-6"	94"
9'-0"	100"
9'-6"	106"
10'-0"	112"
10'-6"	118"
11'-0"	124"
11'-6"	130"
12'-0"	136"
12'-6"	142"
13'-0"	148"
13'-6"	154"
14'-0"	160"
14'-6"	166"
15'-0"	172"
15'-6"	178"
16'-0"	184"
16'-6"	190"
17'-0"	196"
17'-6"	202"
18'-0"	208"
18'-6"	214"
19'-0"	220"
19'-6"	226"
20'-0"	232"

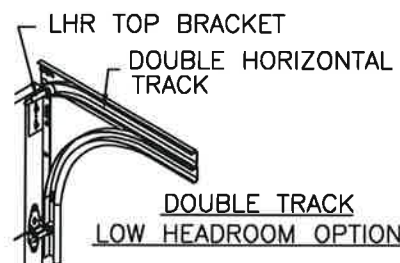

WOOD JAMB ON CONCRETE

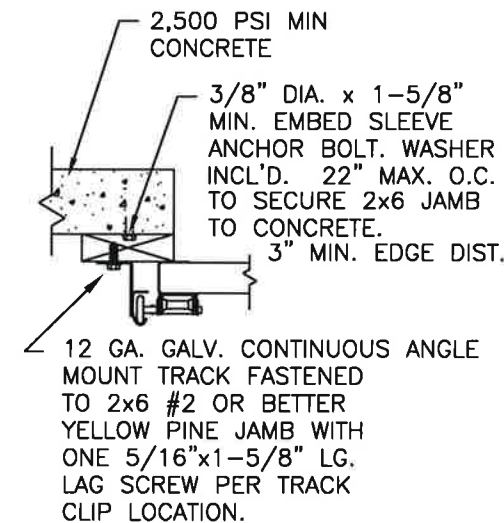

SECTION 3-3

STEEL JAMBS

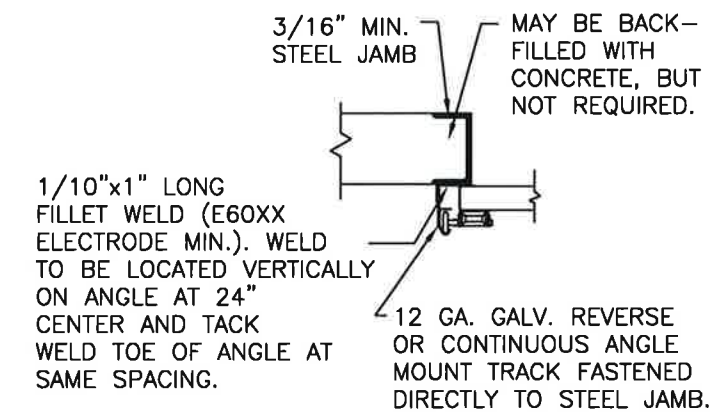

SECTION 3-3

DESIGN ENGINEER:
MARK WESTERFIELD, P.E.
FLORIDA P.E. #48495
NC P.E. #23832, TEXAS P.E. #91513

Mark West
4/21/22

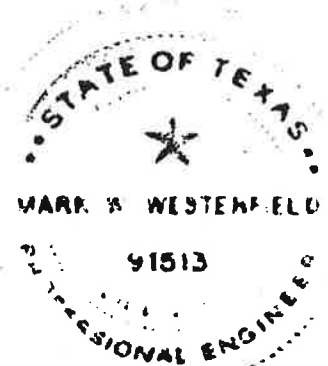

NOTICE:
Confidential/Proprietary information of CLOPAY CORPORATION is contained herein and may not be disclosed, used, duplicated, made available, or distributed without its prior consent. Failure to observe this notice may result in liability for any damages and losses resulting therefrom.

Unless Stated Otherwise TOLERANCES are
.0 = ±.031
.00 = ±.015
.000 = ±.005
.0000 = ±.001
Degrees = ±1/2"

Third Angle Projection

Unless Stated Otherwise DIMENSIONS ARE IN INCHES.

Clopay
CORPORATION

8585 Duke Boulevard
Mason, OH 45040 USA
Tel. No. 513-770-4800
Fax No. 513-770-4853

PART NO.: -

CLOPAY WINDLOAD RATING
W4

DESCRIPTION: M/N 904 20' WIDE DES. +25/-25 PSF

DRAWN BY: J. WHEELER

DATE: 4/7/22

SCALE: NTS

DWG. B

CHECKED BY: SH

DATE: CHKD_DT

SHEET 2 OF 2

DWG. NO.: 105633

REV. NO. 00

4

3

2

1