

Doors tested per ANSI/DASMA 108 for static air pressure

Maximum Door Width	Stiles per Sect.	Hinges per Sect.	Design Loads
8'-2"	2	2	42.3 -47.9
9'-2"	2	2	37.7 -42.7
10'-2"	2	2	34.0 -38.5
12'-2"	3	3	23.7 -26.9

John E. Scates
2560 King Arthur Blvd, Ste 124-54
Lewisville, TX 75056
FL PE #51737
TX PE #56308-12203

Professional Engineer's seal provided only for verification of wind load construction details

Scale: None	7679.01	01/08/19
Drawn by: R. Frey		
Checked by: G. Wedekind		
Date: 01/08/19		
ECO: 7679.01		

Title: Spec, Wind Load AlumaView - AV200, StyleView - CPF, WPF

RAYNOR

1101 East River Road
Dixon, IL 61021

No. **P-2816**

Sheet 1 of 3

Rev **A**

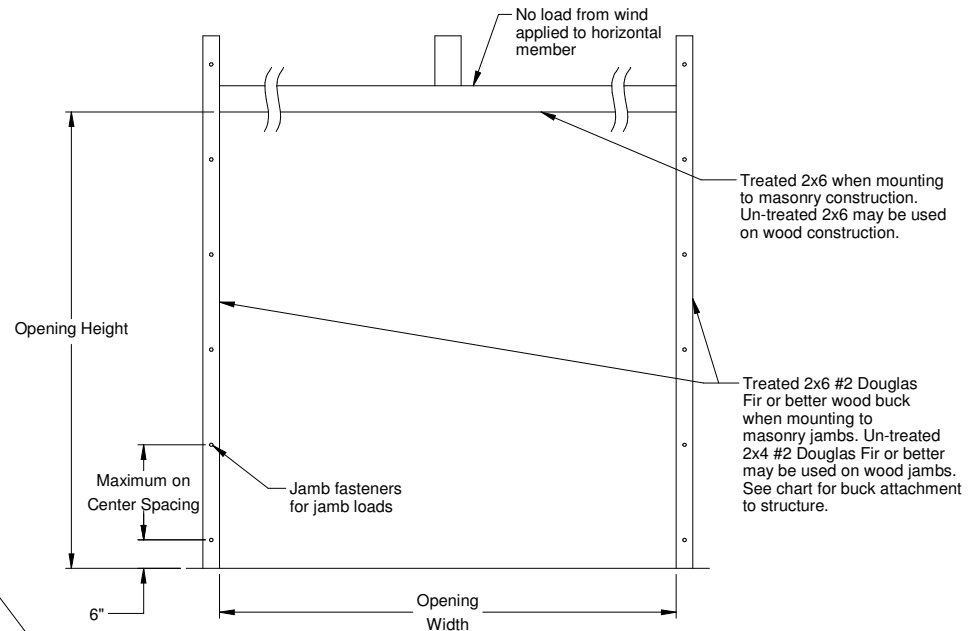
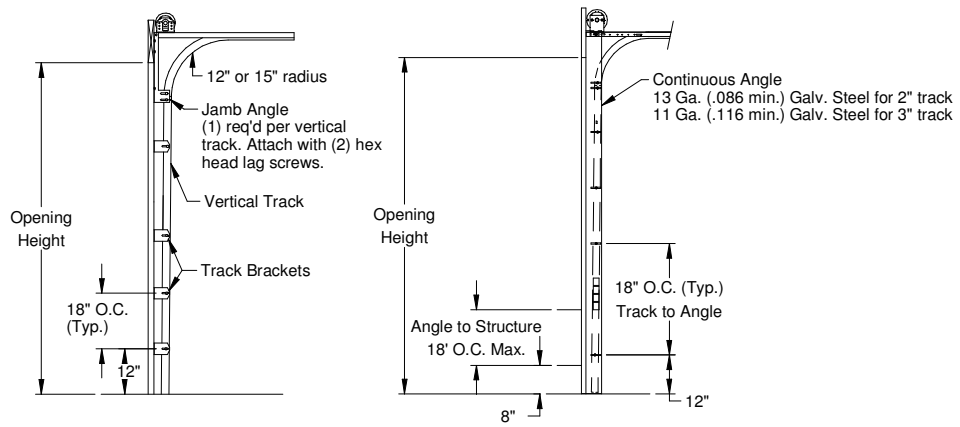

**Typical Track Installation
Bracket Mount
Wood Jamb**

**Typical Track Installation
Angle Mount
Wood, Steel or Concrete Jamb**

Normal headroom track shown, low headroom, lift clearance and vertical lift track available

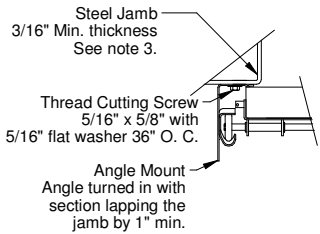

**Track Assembly Attachment
to Steel Jamb**
2" Track Angle Mount turned in Shown
3" Track Angle Mount Available

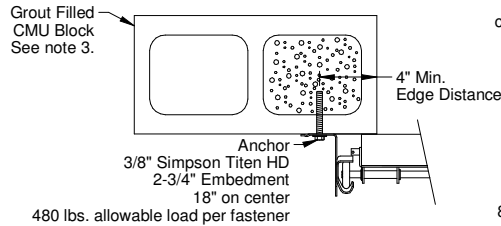

**Track Assembly Attachment
to Grout Filled CMU Block**
2" Track Angle Mount turned out Shown
3" Track Angle Mount Available

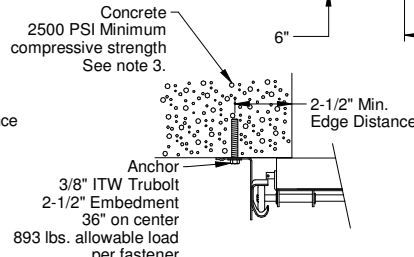

**Track Assembly Attachment
to 2500 PSI Min. Concrete**
2" Track Angle Mount turned out Shown
3" Track Angle Mount Available

Jamb Attachment Notes:

1. Maximum Positive Load per Jamb = $(10' \cdot 2" \times 34.0 \text{ PSF}) / 2 = 173 \text{ lbs. per foot.}$
2. Maximum Negative Load per Jamb = $(10' \cdot 2" \times -38.5 \text{ PSF}) / 2 = 196 \text{ lbs. per foot.}$
3. Design of the supporting structure shall be the sole responsibility of the building designer and shall be designed for the jamb loads listed in notes 1 and 2.
4. Alternate jamb attachments may be used if approved by a registered Professional Engineer.
5. DASMA Technical Data Sheet TDS-161 may be used for alternate jamb attachments.
6. 3/8" diameter lag screws required 1/16" pilot hole and 1-1/2" minimum required distance.

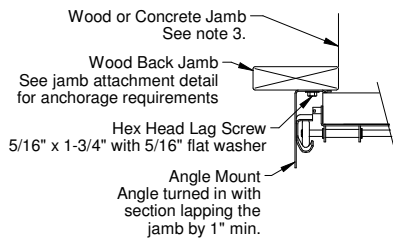

**Track Assembly Attachment
to Wood Back Jamb**
2" Track Angle Mount turned in Shown
3" Track Angle Mount Available

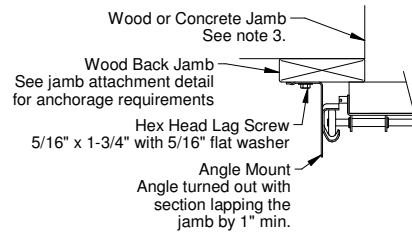

**Track Assembly Attachment
to Wood Back Jamb**
2" Track Angle Mount turned out Shown
3" Track Angle Mount Available

2x6 Attachment to Structure						
Structure Type	Fastener Type	Minimum Embedment	Minimum Edge Distance	Minimum on Center Spacing	Maximum on Center Spacing	Allowable Tension Load
2500 PSI Min. Concrete	1/4" Tapcon+ (Plus) with 1-1/8" OD Washer	2"	2.5	6"	24"	526
Southern Pine	3/8" x 3" Lag with 1-1/8" OD Washer	1.50"	1.50"	1.50"	24"	655
Spruce Pine Fir	3/8" x 3" LAG with 1-1/8" OD Washer	1.50"	1.50"	1.50"	24"	482

Scale: None
 Drawn by: R. Frey
 Checked by: G. Wedekind
 Date: 01/08/19
 ECO: 7679.01



Title: Spec. Wind Load
 AlumaView - AV200,
 StyleView - CPF, WPF

No. P-2816
 Sheet 2
 Rev A

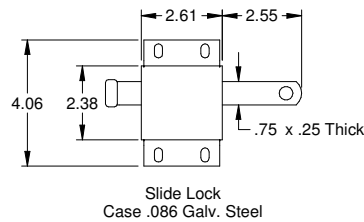
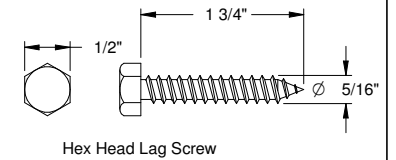
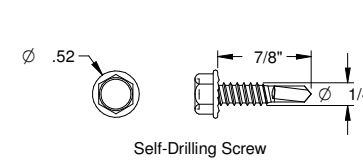
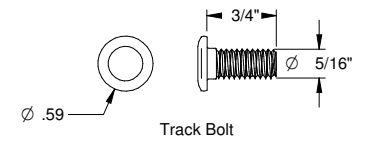
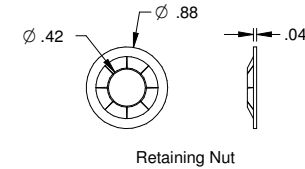
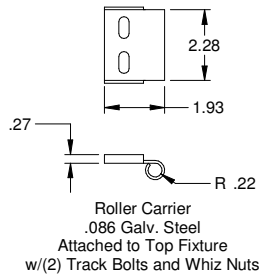
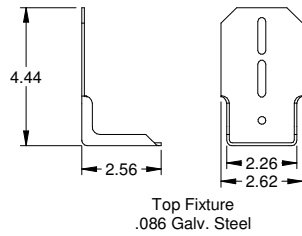
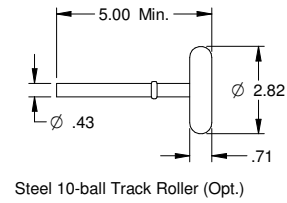
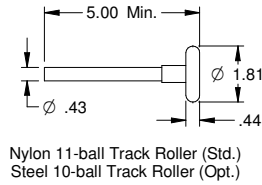
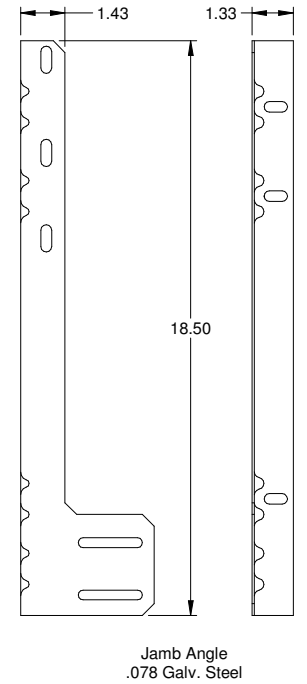
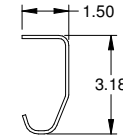
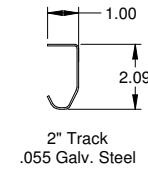
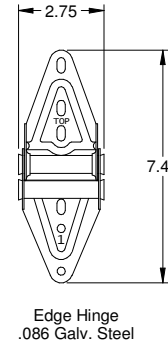
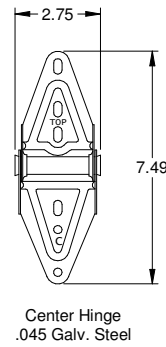
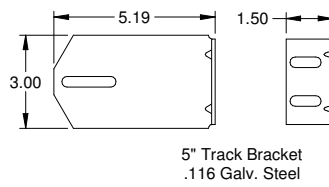
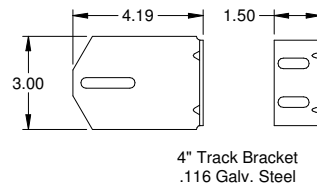
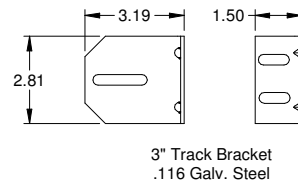
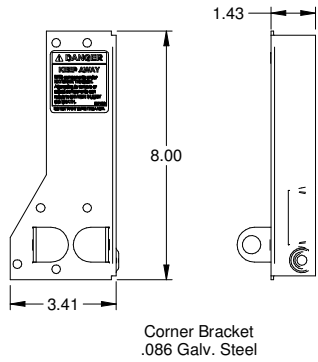

John E. Scates
2560 King Arthur Blvd, Ste 124-54
Lewisville, TX 75056
FL PE #51737
TX PE #56308-12203

Professional Engineer's seal provided only for verification of wind load construction details

Scale: None
Drawn by: R. Frey
Checked by: G. Wedekind
Date: 01/08/19
ECO: 7679.01



Title: Spec. Wind Load
AlumaView - AV200,
StyleView - CPF, WPF

No. P-2816	Sheet 3	Rev A
------------	---------	-------