

NOTES:

1. VINYL OR WOOD DOOR STOP NAILED A MAXIMUM OF 6" O.C. MUST OVERLAP TOP AND BOTH ENDS OF PANELS MINIMUM 7/16" TO MEET NEGATIVE PRESSURES.
2. SLIDE LOCK OR OPERATOR REQUIRED. LOW HEADROOM REQUIRES A LOCK ON THE LEFT AND RIGHT SIDE OF THE DOOR.
3. THE DESIGN OF THE SUPPORTING STRUCTURAL ELEMENTS SHALL BE THE RESPONSIBILITY OF THE PROFESSIONAL OF RECORD FOR THE BUILDING OR STRUCTURE AND IN ACCORDANCE WITH CURRENT BUILDING CODES FOR THE LOADS LISTED ON THIS DRAWING.
4. SECTION STEEL TO HAVE THE FOLLOWING MINIMUM THICKNESS:
EXTERIOR - 27 GA
INTERIOR - 30 GA
5. DOOR JAMB TO BE MINIMUM 2x6 STRUCTURAL GRADE LUMBER AND BE SPRUCE, PINE, OR FIR. REFER TO JAMB CONNECTION SUPPLEMENT FOR ATTACHMENT TO SUPPORTING STRUCTURE.
6. FOR LOW HEAD ROOM LIFT CONDITIONS, TOP BRACKET SHALL BE A LHR TOP BRACKET IN LIEU OF THE BRACKET SHOWN ON THIS DRAWING. SEE LHR, DETAIL A, SHEET 2.
7. GLAZING OPTIONS - .125" MINIMUM TEMPERED GLAZING INSTALLED IN TOP SECTION (WITH OR WITHOUT DECORATIVE LITE FRAME DIVIDERS) MEETS UNIFORM STATIC WIND PRESSURES SHOWN ON THIS DRAWING. GLAZING IS NOT IMPACT RESISTANT AND DOES NOT MEET THE REQUIREMENTS FOR WIND-BORNE DEBRIS REGIONS. MAX CLEAR OPENING 49-1/4" X 19-1/4".
8. 11 GA ROLLER SLIDES WITH WELDED ENDS AND 11 GA REINFORCING BRACKETS REQUIRED FOR DOORS >8' TALL.

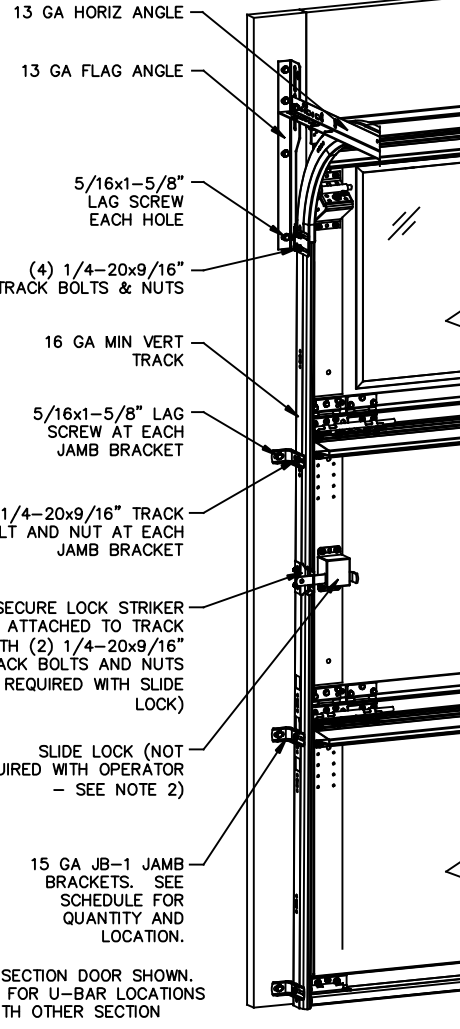

NOTE: (3) SECTION DOOR SHOWN. SEE SHEET 2 FOR U-BAR LOCATIONS ON DOORS WITH OTHER SECTION QUANTITIES.

JAMB BRACKET SCHEDULE			
DOOR HEIGHT	NO. OF SECTIONS	NO. OF JAMB BRACKETS (EACH JAMB)	LOCATION OF CENTERLINE OF JAMB BRACKETS MEASURED FROM BOTTOM OF TRACK (ALL DIMENSIONS ± 2")
7'-0"	3	3	3.5", 24", 53"
8'-0"	4	4	2", 26", 48", 75"
> 8'-0"			SEE NOTE BELOW

NOTE: ALL DOORS GREATER THAN 8' IN HEIGHT REQUIRE USE OF CONTINUOUS WALL ANGLE. SEE SUPPLEMENT TRACK CHART FOR DETAILS.

SUPERIMPOSED DESIGN PRESSURE LOADS ON SUPPORTING STRUCTURE

DOOR WIDTH	DOOR HEIGHT	UNIFORM LOAD EACH JAMB (PLF)
10'-0"	ALL	+114.5/-131.5

PROFESSIONAL ENGINEER'S SEAL PROVIDED ONLY FOR VERIFICATION OF WINDLOAD CONSTRUCTION DETAILS.

The Genuine. The Original.



Lewisville, TX

FASTENERS AT AND MIDWAY BETWEEN ALL INTERMEDIATE HINGE LOCATIONS. SEE NOTE SHEET 2

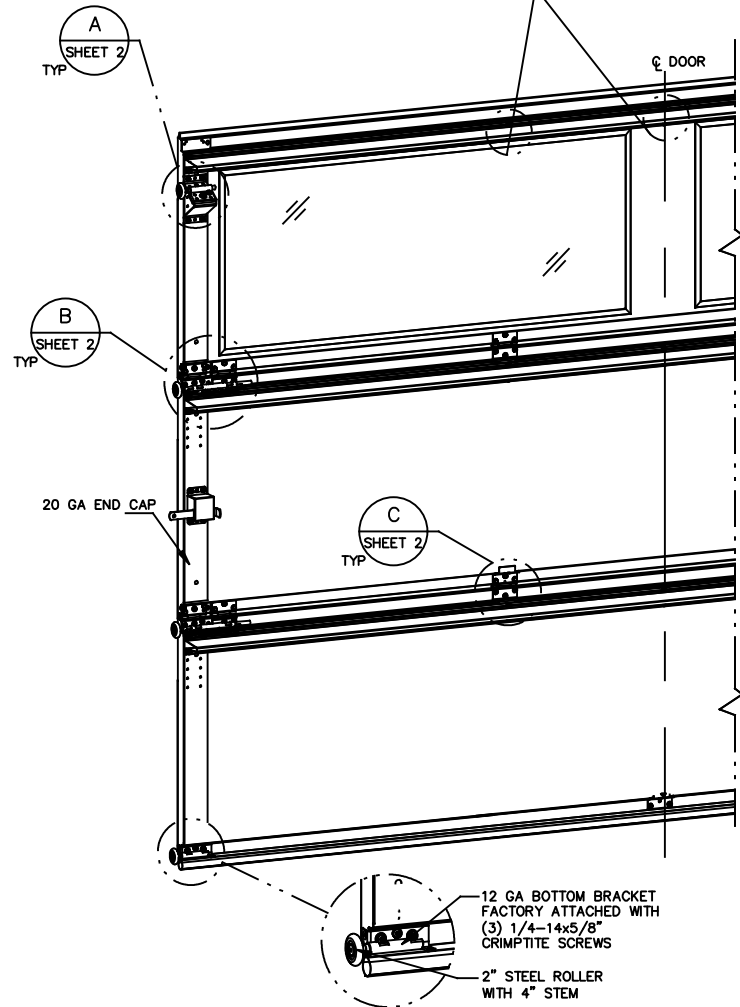

This door has been tested per ANSI/DASMA 108

REVISIONS	
P00	CREATED NEW DRAWING FOR WINDLOAD OPTIONS 8-23-16 GAC

JOHN E. SCATES, PE
3121 FAIRGATE DR.
CARROLLTON, TX 75007
FL. PE 51737 TX. PE 56308/F-2203

STATIC PRESSURE RATINGS		APPROVED SIZES		SCALE: N.T.S.		SIZE: A	
DESIGN (PSF):	+22.90/-26.30	MAX WIDTH:	10'-0"	DATE		NAME	
IMPACT/CYCLIC RATED (YES/NO): NO		MAX HEIGHT:	14'-0"	DRAWN	8-23-16	GAC	
		MAX SECTION HEIGHT:	28"	CHECKED	8-23-16	DK	
MODELS 300-309/5800						SHEET 1 OF 2	
WINDLOAD SPECIFICATION						DRAWING PART NO.	REV.
						411430	P00

LOW HEADROOM TRACK

2" STEEL ROLLER WITH 4" STEM
14GA LHR TOP BRACKET ATTACHED TO DOOR WITH (3) 1/4-20 X 11/16" SELF DRILLING AND (2) #12 X 1/2" PHILLIPS SCREWS

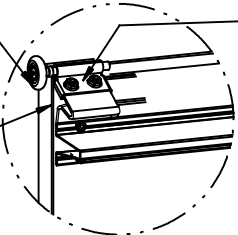

13 GA ROLLER SLIDE ATTACHED TO BRACKET WITH 5/16-18 BOLT & NUT IN CENTER SLOT AND 1/4-20x9/16" TRACK BOLT & NUT THROUGH ANY TWO ALIGNING HOLES

(2) 15 GA HINGE LEAFS ATTACHED WITH (3) 1/4-14x5/8" CRIMP TITE SCREWS EACH

14 GA HINGE BASE FACTORY ATTACHED TO DOOR WITH (5) 1/4-14x5/8" CRIMP TITE SCREWS

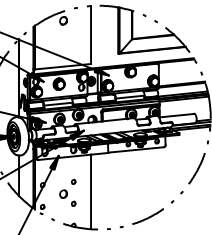

BEFORE U-BAR INSTALLATION

2" STEEL ROLLER WITH 9" STEM

13 GA ROLLER CARRIERS FACTORY ATTACHED TO HINGE BASE AND REINFORCING BRACKET. (EXCEPTION: NOTE #8)

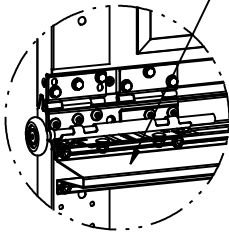

AFTER U-BAR INSTALLATION

13 GA REINFORCING BRACKET ATTACHED BENEATH HINGE BASE. (EXCEPTION: NOTE #8)

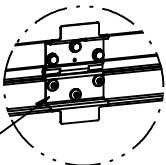

BEFORE U-BAR INSTALLATION

15 GA HINGE ATTACHED WITH (6) 1/4-14x5/8" CRIMP TITE SCREWS (3 OF WHICH ARE FACTORY ATTACHED)



AFTER U-BAR INSTALLATION

DETAIL C

STANDARD LIFT TRACK

2" STEEL ROLLER WITH 4" STEM



13 GA COMMERCIAL 'A' FRAME TOP BRACKET ATTACHED WITH (4) 1/4-20x7/8" SELF DRILLING SCREWS

13 GA ROLLER SLIDE ATTACHED TO BRACKET WITH 5/16-18 BOLT & NUT IN CENTER SLOT AND 1/4-20x9/16" TRACK BOLT & NUT THROUGH ANY TWO ALIGNING HOLES

DETAIL A

POSITION U-BAR OVER REINFORCING BRACKET AND ATTACH WITH (3) 1/4-20x7/8" SELF DRILLING SCREWS AS SHOWN (2 OF WHICH ATTACH THROUGH REINFORCING BRACKET)

POSITION U-BAR OVER HINGE LEAF AND ATTACH WITH (1) 1/4-14x5/8" CRIMP TITE SCREW AND (1) 1/4-20x7/8" SELF DRILLING SCREW AS SHOWN (SELF DRILLING SCREW ATTACHES THROUGH HINGE LEAF)

UNLESS NOTED OTHERWISE, ALL U-BARS SHALL BE ATTACHED WITH A MINIMUM OF (2) FASTENERS AT EACH END, AT ALL INTERMEDIATE HINGE LOCATIONS (OR IN LINE WITH INTERMEDIATE HINGE LOCATIONS IF U-BAR IS NOT LOCATED AT A HINGE), AND MIDWAY BETWEEN INTERMEDIATE HINGE LOCATIONS (MINIMUM OF (10) FASTENERS EACH U-BAR). ALL FASTENERS USED TO ATTACH U-BARS SHALL BE 1/4-14x5/8" CRIMP TITE SCREWS EXCEPT 1/4-20x7/8" SELF DRILLING SCREWS SHALL BE USED AT END CAPS AND WHERE FASTENING THROUGH HINGE LEAFS OR BRACKETS.

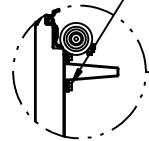

U-BAR LOCATIONS

(7) SECTION DOORS WITH (7) 3" 20 GA 80 KSI U-BARS LOCATED AS SHOWN (TOP BRACKET REMOVED FOR CLARITY)

(6) SECTION DOORS WITH (6) 3" 20 GA 80 KSI U-BARS LOCATED AS SHOWN (TOP BRACKET REMOVED FOR CLARITY)

(5) SECTION DOORS WITH (5) 3" 20 GA 80 KSI U-BARS LOCATED AS SHOWN (TOP BRACKET REMOVED FOR CLARITY)

(4) SECTION DOORS WITH (4) 3" 20 GA 80 KSI U-BARS LOCATED AS SHOWN (TOP BRACKET REMOVED FOR CLARITY)

(3) SECTION DOORS WITH (3) 3" 20 GA 80 KSI U-BARS LOCATED AS SHOWN (TOP BRACKET REMOVED FOR CLARITY)

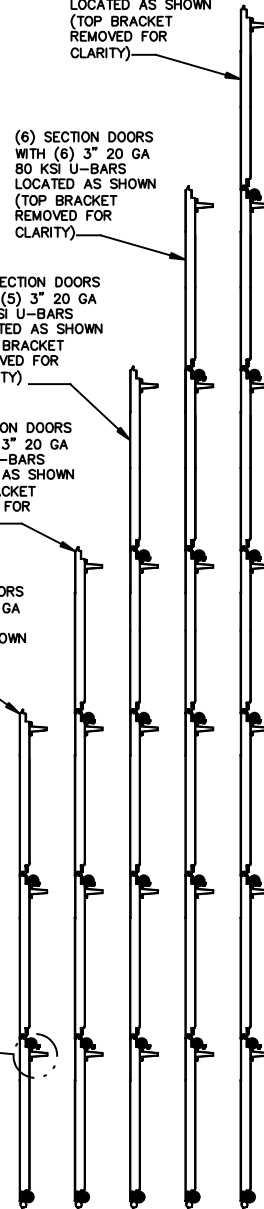

REVISIONS

JOHN E. SCATES, PE
3121 FAIRGATE DR.
CARROLLTON, TX 75007
FL. PE. 51737 TX. PE. 56308/F-2203

PROFESSIONAL ENGINEER'S SEAL PROVIDED ONLY FOR VERIFICATION OF WINDLOAD CONSTRUCTION DETAILS.

The Genuine. The Original.



Lewisville, TX

	STATIC PRESSURE RATINGS		APPROVED SIZES		SCALE: N.T.S.	SIZE: A	
	DESIGN (PSF):	+22.90/-26.30	MAX WIDTH:	10'-0"	DATE	NAME	
	IMPACT/CYCLIC RATED (YES/NO):	NO	MAX HEIGHT:	14'-0"	DRAWN	8-23-16	GAC
			MAX SECTION HEIGHT:	28"	CHECKED	8-23-16	DK
MODELS 300-309/5800					SHEET 2 OF 2		
WINDLOAD SPECIFICATION					DRAWING PART NO.	REV.	
					411430	P00	