

**NOTES:**

1. VINYL OR WOOD DOOR STOP NAILED A MAXIMUM OF 6" O.C. MUST OVERLAP TOP AND BOTH ENDS OF PANELS MINIMUM 7/16" TO MEET NEGATIVE PRESSURES.

2. SLIDE LOCK OR OPERATOR REQUIRED. LOW HEADROOM REQUIRES A LOCK ON THE LEFT AND RIGHT SIDE OF THE DOOR.

3. THE DESIGN OF THE SUPPORTING STRUCTURAL ELEMENTS SHALL BE THE RESPONSIBILITY OF THE PROFESSIONAL OF RECORD FOR THE BUILDING OR STRUCTURE AND IN ACCORDANCE WITH CURRENT BUILDING CODES FOR THE LOADS LISTED ON THIS DRAWING.

4. SECTION STEEL TO HAVE THE FOLLOWING MINIMUM THICKNESS: EXTERIOR - 27 GA INTERIOR - 30 GA

5. DOOR JAMB TO BE MINIMUM 2x6 STRUCTURAL GRADE LUMBER AND BE SPRUCE, PINE, OR FIR. REFER TO JAMB CONNECTION SUPPLEMENT FOR ATTACHMENT TO SUPPORTING STRUCTURE.

6. FOR LOW HEAD ROOM LIFT CONDITIONS, TOP BRACKET SHALL BE A LHR TOP BRACKET IN LIEU OF THE BRACKET SHOWN ON THIS DRAWING. SEE LHR, DETAIL A, SHEET 2.

7. 11 GA ROLLER SLIDES WITH WELDED ENDS AND 11 GA REINFORCING BRACKETS REQUIRED FOR DOORS > 8' TALL.

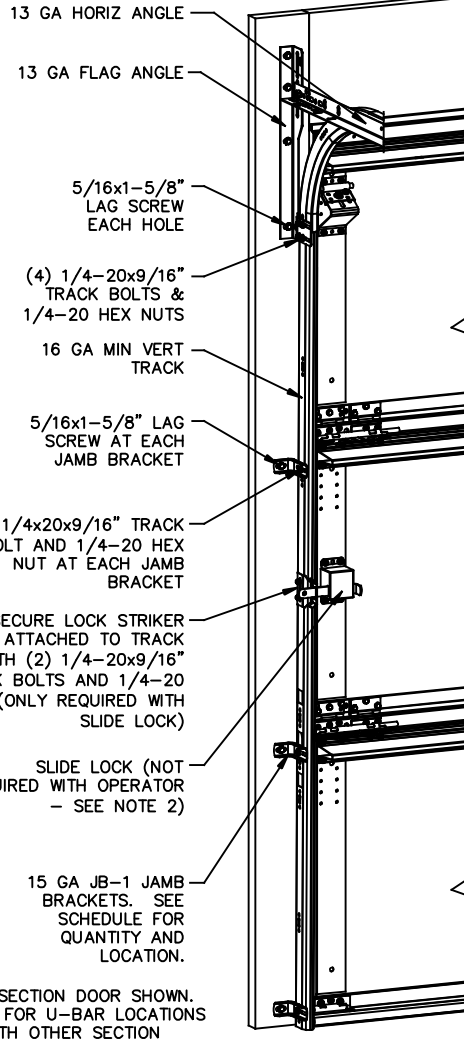

NOTE: (3) SECTION DOOR SHOWN. SEE SHEET 2 FOR U-BAR LOCATIONS ON DOORS WITH OTHER SECTION QUANTITIES.

JAMB BRACKET SCHEDULE			
DOOR HEIGHT	NO. OF SECTIONS	NO. OF JAMB BRACKETS (EACH JAMB)	LOCATION OF CENTERLINE OF JAMB BRACKETS MEASURED FROM BOTTOM OF TRACK (ALL DIMENSIONS ± 2")
7'-0"	3	3	2", 26", 53"
8'-0"	4	4	2", 26", 48", 75"
> 8'-0"			SEE NOTE BELOW

**NOTE:**

ALL DOORS GREATER THAN 8' IN HEIGHT REQUIRE USE OF CONTINUOUS WALL ANGLE. SEE SUPPLEMENT TRACK CHART FOR DETAILS.

**SUPERIMPOSED DESIGN PRESSURE LOADS ON SUPPORTING STRUCTURE**

DOOR WIDTH	DOOR HEIGHT	UNIFORM LOAD EACH JAMB (PLF)
9'-0"	ALL	+121.1/-138.6
8'-0"	ALL	+107.6/-123.2

PROFESSIONAL ENGINEER'S SEAL PROVIDED ONLY FOR VERIFICATION OF WINDLOAD CONSTRUCTION DETAILS.

The Genuine. The Original.



Louisville, TX

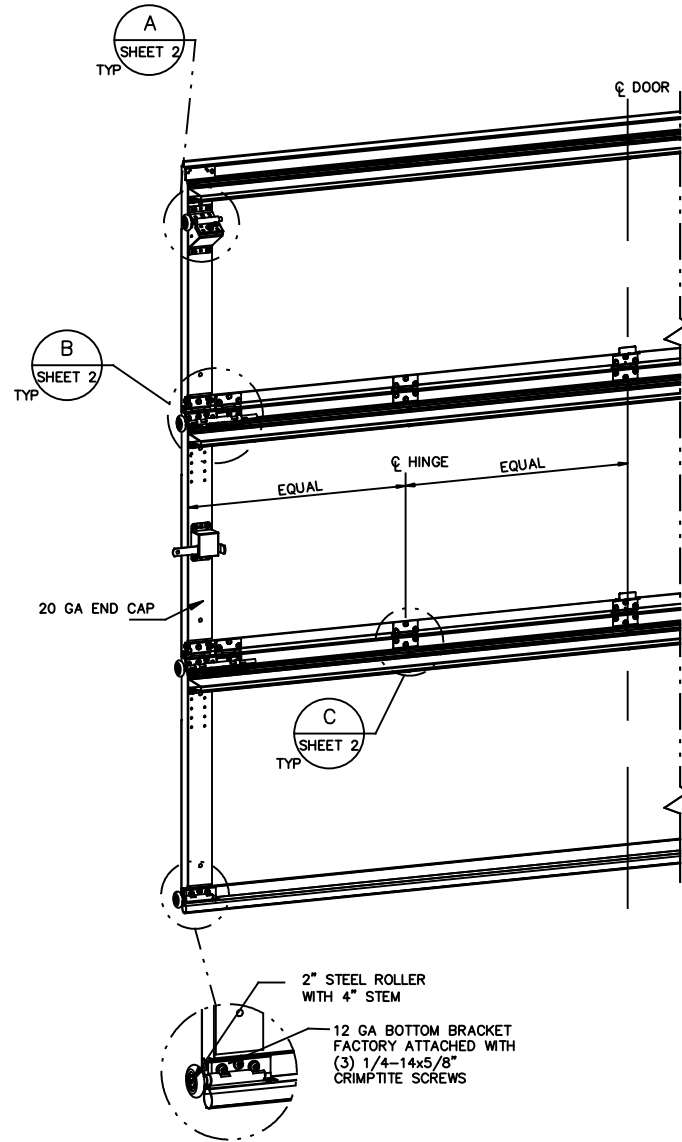

REVISIONS  
P00 CREATED NEW DRAWING FOR WINDLOAD OPTIONS 8-23-16 GAC

This door has been tested per ANSI/DASMA 108

STATIC PRESSURE RATINGS		APPROVED SIZES		SCALE: N.T.S.		SIZE: A	
DESIGN (PSF):	+26.90/-30.80	MAX WIDTH:	9'-0"	DATE	8-23-16	NAME	GAC
IMPACT/CYCLIC RATED (YES/NO): NO		MAX HEIGHT:	14'-0"	DRAWN	8-23-16	DK	
		MAX SECTION HEIGHT:	28"	CHECKED	8-23-16		
MODELS 300-309/5800				SHEET 1 OF 2			
WINDLOAD SPECIFICATION				DRAWING PART NO.		REV.	
				411419		P00	

LOW HEADROOM TRACK

2" STEEL ROLLER WITH 4" STEM  
14GA LHR TOP BRACKET ATTACHED TO DOOR WITH (3) 1/4-20 X 11/16" SELF DRILLING AND (2) #12 X 1/2" PHILLIPS SCREWS

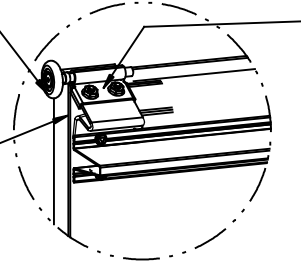

13 GA STEEL ROLLER SLIDE ATTACHED WITH (2) 1/4-20x5/8" CARRIAGE BOLTS, (2) RETENSION WASHERS, AND (2) 1/4-20 HEX FLANGE NUT.

STANDARD LIFT TRACK

2" STEEL ROLLER WITH 4" STEM

13 GA COMMERCIAL 'A' FRAME TOP BRACKET ATTACHED WITH (4) 1/4-20x7/8" SELF DRILLING SCREWS

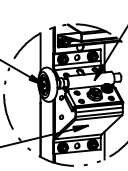

13 GA ROLLER SLIDE ATTACHED TO BRACKET WITH 5/16-18 BOLT & NUT IN CENTER SLOT AND 1/4-20x9/16" TRACK BOLT & 1/4-20 HEX NUT THROUGH ANY TWO ALIGNING HOLES

U-BAR LOCATIONS (7) SECTION DOORS WITH (7) 3" 20 GA 80 KSI U-BARS LOCATED AS SHOWN (TOP BRACKET REMOVED FOR CLARITY)

(6) SECTION DOORS WITH (6) 3" 20 GA 80 KSI U-BARS LOCATED AS SHOWN (TOP BRACKET REMOVED FOR CLARITY)

(5) SECTION DOORS WITH (5) 3" 20 GA 80 KSI U-BARS LOCATED AS SHOWN (TOP BRACKET REMOVED FOR CLARITY)

(4) SECTION DOORS WITH (4) 3" 20 GA 80 KSI U-BARS LOCATED AS SHOWN (TOP BRACKET REMOVED FOR CLARITY)

(3) SECTION DOORS WITH (3) 3" 20 GA 80 KSI U-BARS LOCATED AS SHOWN (TOP BRACKET REMOVED FOR CLARITY)

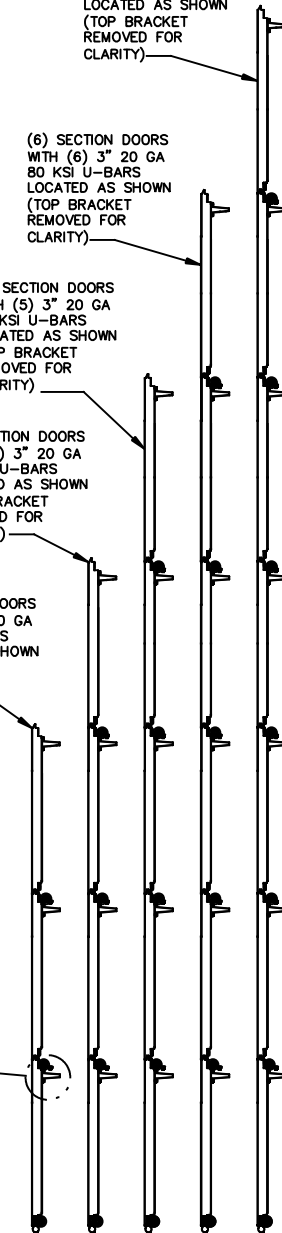

DETAIL A

(2) 15 GA HINGE LEAFS ATTACHED WITH (3) 1/4-14x5/8" CRIMP TITE SCREWS EACH

14 GA HINGE BASE FACTORY ATTACHED TO DOOR WITH (5) 1/4-14x5/8" CRIMP TITE SCREWS

2" STEEL ROLLER WITH 9" STEM

13 GA ROLLER CARRIERS FACTORY ATTACHED TO HINGE BASE AND REINFORCING BRACKET. (EXCEPTION: NOTE #7)

13 GA REINFORCING BRACKET ATTACHED BENEATH HINGE BASE. (EXCEPTION: NOTE #7)

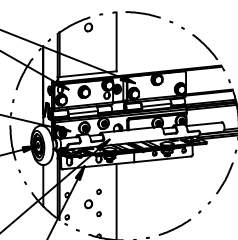

BEFORE U-BAR INSTALLATION

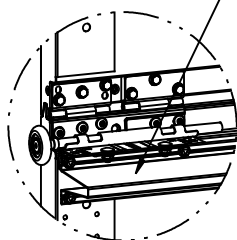

AFTER U-BAR INSTALLATION

POSITION U-BAR OVER REINFORCING BRACKET AND ATTACH WITH (3) 1/4-20x7/8" SELF DRILLING SCREWS AS SHOWN (2 OF WHICH ATTACH THROUGH REINFORCING BRACKET)

DETAIL B

UNLESS NOTED OTHERWISE, ALL U-BARS SHALL BE ATTACHED WITH A MINIMUM OF (2) FASTENERS AT EACH END, AT ALL INTERMEDIATE HINGE LOCATIONS (OR IN LINE WITH INTERMEDIATE HINGE LOCATIONS IF U-BAR IS NOT LOCATED AT A HINGE), AND MIDWAY BETWEEN INTERMEDIATE HINGE LOCATIONS (MINIMUM OF (10) FASTENERS EACH U-BAR). ALL FASTENERS USED TO ATTACH U-BARS SHALL BE 1/4-14x5/8" CRIMP TITE SCREWS EXCEPT 1/4-20x7/8" SELF DRILLING SCREWS SHALL BE USED AT END CAPS AND WHERE FASTENING THROUGH HINGE LEAFS OR BRACKETS.

15 GA HINGE ATTACHED WITH (6) 1/4-14x5/8" CRIMP TITE SCREWS

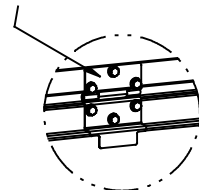

BEFORE U-BAR INSTALLATION



AFTER U-BAR INSTALLATION

POSITION U-BAR OVER HINGE LEAF AND ATTACH WITH (1) 1/4-14x5/8" CRIMP TITE SCREW AND (1) 1/4-20x7/8" SELF DRILLING SCREW AS SHOWN (SELF DRILLING SCREW ATTACHES THROUGH HINGE LEAF)

DETAIL C

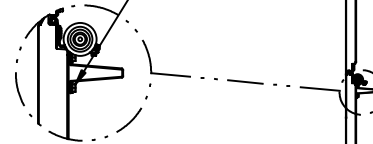

The Genuine. The Original.



Lewisville, TX

STATIC PRESSURE RATINGS	APPROVED SIZES	SCALE: N.T.S.	SIZE: A
DESIGN (PSF): +26.90/-30.80	MAX WIDTH: 9'-0"	DATE	NAME
IMPACT/CYCLIC RATED (YES/NO): NO	MAX HEIGHT: 14'-0"	DRAWN	GAC
	MAX SECTION HEIGHT: 28"	CHECKED	DK
MODELS 300-309/5800		SHEET 2 OF 2	
WINDLOAD SPECIFICATION		DRAWING PART NO.	REV.
		411419	P00

REVISIONS