

THE METHOD OF TESTING WAS IN SUBSTANTIAL CONFORMANCE WITH THE PROCEDURE DESCRIBED IN ASTM E330 AND DASMA 108. THE PRESSURES SHOWN ON THE DRAWINGS WERE CALCULATED USING ASCE 7-98/02/05 WITH THE FOLLOWING PARAMETERS (5 FEET OF DOOR WIDTH IN THE END ZONE, ROOF AT ANY SLOPE, AND I=1.0):

WIND SPEED (MPH)	110	100	95	91	87
EXPOSURE LEVEL	B	C	C	D	D
MEAN ROOF HEIGHT	30'	15'	25'	15'	25'

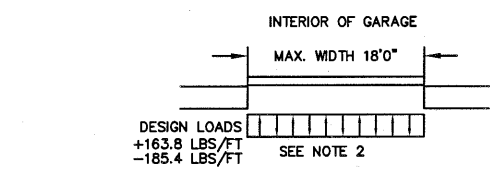

- SPECIFICATIONS AND NOTES**
- ALL THE LOAD FROM THE DOOR IS TRANSFERRED TO THE VERTICAL TRACK. FROM THE TRACK THE LOAD IS TRANSFERRED TO THE VERTICAL JAMBS. THE HORIZONTAL JAMB OR HEADER RECEIVES NO PORTION OF THE LOAD TRANSFERRED FROM THE DOOR.
  - EACH VERTICAL JAMB RECEIVES MAXIMUM DESIGN LOADS OF: +163.8 LBS/FT & -185.4 LBS/FT
  - DOORS AND HARDWARE WILL BE DESIGNED, MANUFACTURED AND INSTALLED WITH STANDARDS AS SET FORTH BY DASMA.
  - DOOR SECTIONS SHALL BE 25 GA. MIN. (.019") ROLLED FORMED LIGHT COMMERCIAL QUALITY
  - SUPPORTING STRUCTURAL ELEMENTS SHALL BE DESIGNED BY A REGISTERED PROFESSIONAL ENGINEER FOR WIND LOADS INDICATED ON THIS DRAWING IN ADDITION TO OTHER LOADINGS.
  - REFER TO TABLES ON THE REVERSE SIDE FOR ADDITIONAL DOOR WIDTHS AND THEIR DESIGN PRESSURES

REV	DESCRIPTION OF REVISIONS	DATE	BY
A	UPDATED BOTTOM BRACKET INFORMATION ADDED OAKSUMMIT AND GLAZING OPTIONS	08/30/05	DLJ
B	REVISED NOTE 6	09/02/08	DLJ
C	WIND SPEED TABLE & TRACK CONFIGURATIONS	04/20/12	RLR
D	ADDED JAMB BRACKET	12/18/12	RLR
E	ADDED LONG PANEL GLAZING OPTION/ADDED HINGES	02/08/17	RLR

MAX SIZE  
18' WIDTH  
14' HEIGHT  
(DOOR HEIGHT SUBJECT TO WEIGHT LIMITATIONS)

DESIGN LOADS  
+18.2 PSF  
-20.6 PSF

TEST LOADS  
(1.5 x DESIGN LOADS)  
+27.3 PSF  
-30.9 PSF

Thomas L. Shelmerdine, PE (TX PE #85829)  
Structural Solutions, PA (TX Firm #F-004063)

TX

5921-G W. Friendly Ave., Greensboro, NC 27410

**Amarr**  
ENTREMATIc

MODEL #650 AMARR OAK SUMMIT 1000, 2000  
MODEL #600 AMARR STRATFORD 1000, 2000  
MODEL #950 HERITAGE 1000, 2000  
Short, Long, Flush & Oak Summit Panel's

SIZE	DRAWN BY DLJ	DATE 09/10/03	DRAWING NUMBER
B	CHECKED BY AAE	DATE 09/10/03	IRC-6018-110-15

ENTREMATIc  
165 CARRIAGE COURT WINSTON-SALEM, N.C. 27105

SHEET 1 OF 3

WOOD JAMB ATTACHMENT TO STRUCTURE

GLAZING OPTION CROSS SECTION

GLAZING NOT AVAILABLE IN WIND-BORNE DEBRIS REGION  
GLAZING MEETS ASTM E1300-04

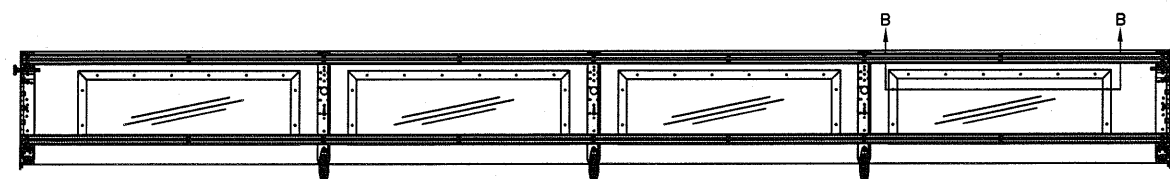
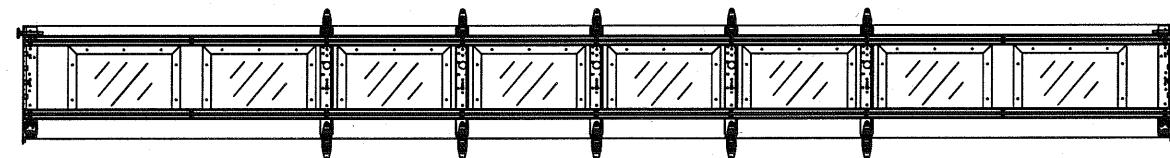
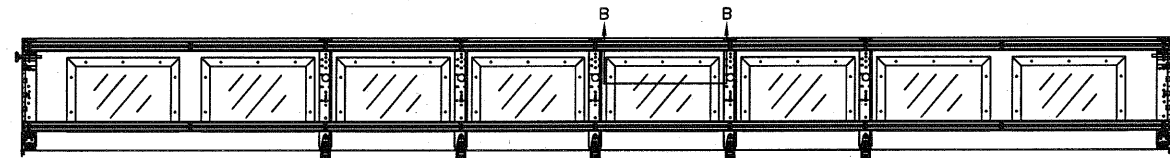
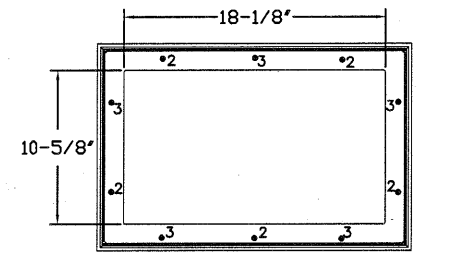
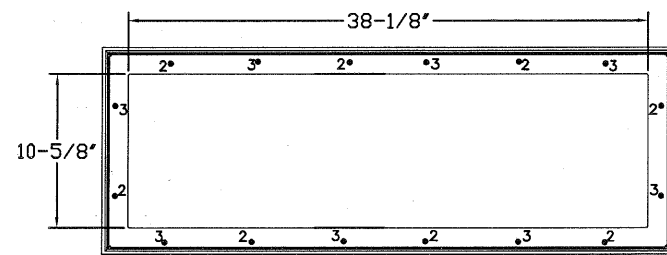
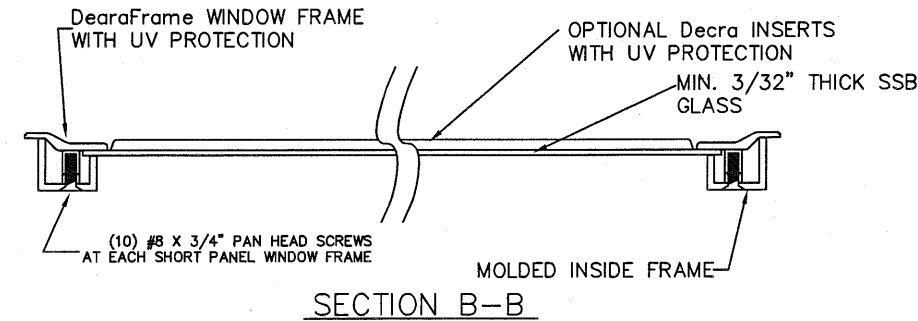

\*LONG PANEL GLAZING ONLY AVAILABLE IN TOP SECTION

2 X 6 VERTICAL JAMB ATTACHMENT TO WOOD FRAME STRUCTURE  
5/16" X 3' LAG SCREWS STARTING 6" FROM ENDS THEN 24" O.C. (1 1/2" EMBEDMENT)  
2 X 6 VERTICAL JAMB ATTACHMENT TO 2,000 PSI CONCRETE  
HILTI KWIK BOLT 3/8" X 4" STARTING 6" FROM ENDS THEN 24" O.C. (2 1/2" EMBEDMENT)  
HILTI SLEEVE ANCHOR 3/8" X 2-3/4" STARTING 6" FROM ENDS THEN 24" O.C. (1 1/4" EMBEDMENT)  
ITW/RAMSET REDHEAD (TRU-BOLT) 3/8" X 4" STARTING 6" FROM ENDS THEN 24" O.C. (2 1/2" EMBEDMENT)  
2 X 6 VERTICAL JAMB ATTACHMENT TO HOLLOW C-90 BLOCK  
SIMPSON 1/4" X 3" TITEN SCREWS STARTING 6" FROM ENDS, USE PAIRS OF FASTENERS (3" APART) AT 16" O.C. (1 1/2" EMBEDMENT)  
HILTI 1/4" X 2-3/4" KWIK-CON II+ SCREWS STARTING 6" FROM ENDS, USE PAIRS OF FASTENERS (3" APART) AT 16" O.C. (1 1/4" EMBEDMENT)

2 X 6 VERTICAL JAMB ATTACHMENT TO GROUTED C-90 BLOCK (2000 PSI GROUT)  
HILTI SLEEVE ANCHOR 3/8" X 2-3/4" STARTING 6" FROM ENDS THEN 24" O.C. (1 1/4" EMBEDMENT) (OR, USE FASTENERS FOR HOLLOW C-90 BLOCK)

\*LAGS AND BOLTS CAN BE COUNTERSUNK TO PROVIDE A FLUSH MOUNTING SURFACE.  
\*PREPARATION OF WOOD JAMBS BY OTHERS

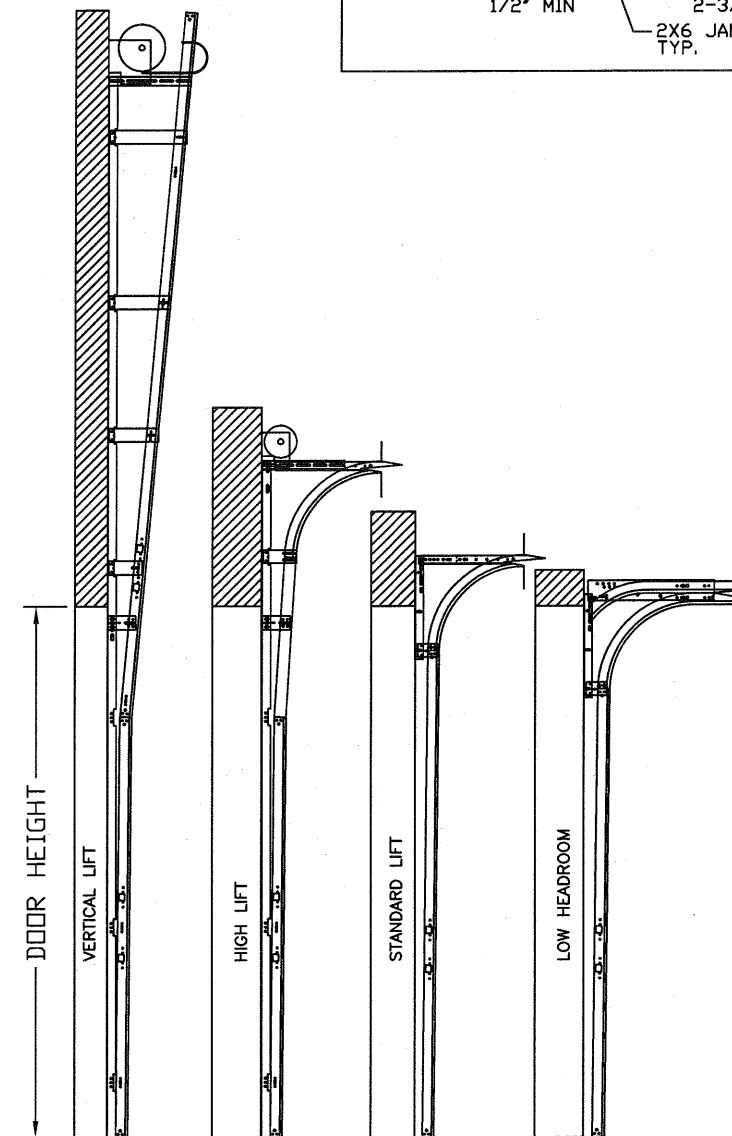
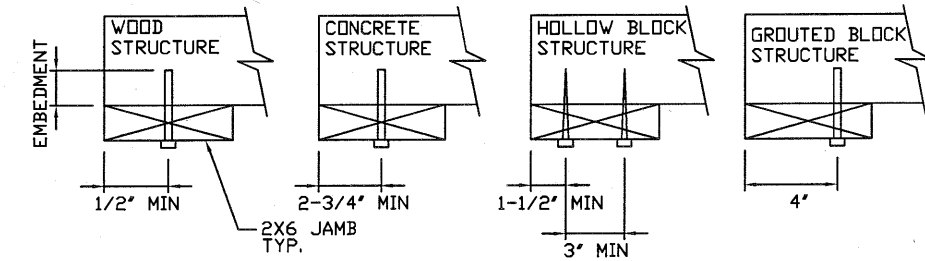

AVAILABLE TRACK CONFIGURATIONS  
N.T.S.

REV	DESCRIPTION OF REVISIONS	DATE	BY
A	UPDATED BOTTOM BRACKET INFORMATION ADDED OAKSUMMIT AND GLAZING OPTIONS	08/30/05	DLJ
B	REVISED NOTE 6	09/02/08	DLJ
C	WIND SPEED TABLE & TRACK CONFIGURATIONS	04/20/12	RLR
D	ADDED JAMB BRACKET	12/18/12	RLR
E	ADDED LONG PANEL GLAZING OPTION/ADDED HINGES	02/08/17	RLR

MAX SIZE  
18' WIDTH  
14' HEIGHT  
(DOOR HEIGHT SUBJECT TO WEIGHT LIMITATIONS)  
DESIGN LOADS  
+18.2 PSF  
-20.6 PSF  
TEST LOADS (1.5 x DESIGN LOADS)  
+27.3 PSF  
-30.9 PSF

Thomas L. Shelmerdine, PE (TX PE #85829)  
Structural Solutions, PA (TX Firm #F-004065)

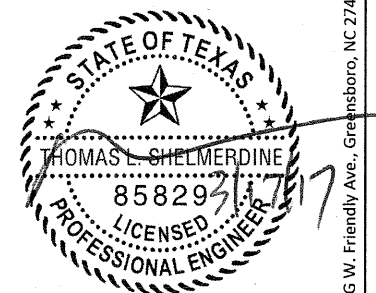

TX

Amarr  
ENTREMATICA

MODEL #650 AMARR OAK SUMMIT 1000, 2000  
MODEL #600 AMARR STRATFORD 1000, 2000  
MODEL #950 HERITAGE 1000, 2000  
Short, Long, Flush & Oak Summit Panel's

SIZE	DRAWN BY	DLJ	DATE	09/10/03	DRAWING NUMBER
B	CHECKED BY	AAE	DATE	09/10/03	IRC-6018-110-15

ENTREMATICA  
165 CARRIAGE COURT WINSTON-SALEM, N.C. 27105 SHEET 2 OF 3

5921-G.W. Friendly Ave., Greensboro, NC 27410

**TABLE 1**

DOOR HEIGHT	STRUT SPACING (BASED ON RECOMMENDED SECTION CONFIGURATION)															TOP
	A	B	C	D	E	F	G	H	I	J	K	L	M	N	O	
6' 6"	5 1/2"	18 1/4"	25 1/2"	36 1/4"	43 1/2"	54 1/4"	61 1/2"									76 1/2"
7'	5 1/2"	18 1/4"	25 1/2"	39 1/4"	46 1/2"	60 1/4"	67 1/2"									82 1/2"
7' 6"	5 1/2"	15 1/4"	22 1/2"	33 1/4"	40 1/2"	51 1/4"	58 1/2"	69 1/4"	76 1/2"							88 1/2"
8'	5 1/2"	18 1/4"	25 1/2"	36 1/4"	43 1/2"	54 1/4"	61 1/2"	72 1/4"	79 1/2"							94 1/2"
8' 6"	5 1/2"	18 1/4"	25 1/2"	39 1/4"	46 1/2"	60 1/4"	67 1/2"	78 1/4"	85 1/2"							100 1/2"
9'	5 1/2"	15 1/4"	22 1/2"	33 1/4"	40 1/2"	51 1/4"	58 1/2"	69 1/4"	76 1/2"	87 1/4"	94 1/2"					106 1/2"
9' 6"	5 1/2"	18 1/4"	25 1/2"	36 1/4"	43 1/2"	54 1/4"	61 1/2"	72 1/4"	79 1/2"	90 1/4"	97 1/2"					112 1/2"
10'	5 1/2"	18 1/4"	25 1/2"	39 1/4"	46 1/2"	60 1/4"	67 1/2"	78 1/4"	85 1/2"	96 1/4"	103 1/2"					118 1/2"
10' 6"	5 1/2"	18 1/4"	25 1/2"	39 1/4"	46 1/2"	60 1/4"	67 1/2"	81 1/4"	88 1/2"	102 1/4"	109 1/2"					124 1/2"
11'	5 1/2"	18 1/4"	25 1/2"	36 1/4"	43 1/2"	54 1/4"	61 1/2"	72 1/4"	79 1/2"	90 1/4"	97 1/2"	108 1/4"	115 1/2"			130 1/2"
11' 6"	5 1/2"	18 1/4"	25 1/2"	39 1/4"	46 1/2"	60 1/4"	67 1/2"	78 1/4"	85 1/2"	96 1/4"	103 1/2"	114 1/4"	121 1/2"			136 1/2"
12'	5 1/2"	18 1/4"	25 1/2"	39 1/4"	46 1/2"	60 1/4"	67 1/2"	81 1/4"	88 1/2"	102 1/4"	109 1/2"	120 1/4"	127 1/2"			142 1/2"
12' 6"	5 1/2"	18 1/4"	25 1/2"	36 1/4"	43 1/2"	54 1/4"	61 1/2"	72 1/4"	79 1/2"	90 1/4"	97 1/2"	108 1/4"	115 1/2"	126 1/4"	133 1/2"	148 1/2"
13'	5 1/2"	18 1/4"	25 1/2"	39 1/4"	46 1/2"	60 1/4"	67 1/2"	78 1/4"	85 1/2"	96 1/4"	103 1/2"	114 1/4"	121 1/2"	132 1/4"	139 1/2"	154 1/2"
13' 6"	5 1/2"	18 1/4"	25 1/2"	39 1/4"	46 1/2"	60 1/4"	67 1/2"	81 1/4"	88 1/2"	102 1/4"	109 1/2"	120 1/4"	127 1/2"	138 1/4"	145 1/2"	160 1/2"
14'	5 1/2"	18 1/4"	25 1/2"	39 1/4"	46 1/2"	60 1/4"	67 1/2"	81 1/4"	88 1/2"	102 1/4"	109 1/2"	123 1/4"	130 1/2"	144 1/4"	151 1/2"	166 1/2"

**TABLE 2**

DOOR HEIGHT	SECTION HEIGHTS							
	Btm	#2	#3	#4	#5	#6	#7	#8
14' 0"	21"	21"	21"	21"	21"	21"	21"	21"
13' 6"	21"	21"	21"	21"	21"	18"	18"	21"
13' 0"	21"	21"	21"	18"	18"	18"	18"	21"
12' 6"	21"	18"	18"	18"	18"	18"	18"	21"
12' 0"	21"	21"	21"	21"	21"	18"	21"	
11' 6"	21"	21"	21"	18"	18"	18"	21"	
11' 0"	21"	18"	18"	18"	18"	18"	21"	
10' 6"	21"	21"	21"	21"	21"	21"		
10' 0"	21"	21"	21"	18"	18"	21"		
9' 6"	21"	18"	18"	18"	18"	21"		
9' 0"	18"	18"	18"	18"	18"	18"		
8' 6"	21"	21"	21"	18"	21"			
8' 0"	21"	18"	18"	18"	21"			
7' 6"	18"	18"	18"	18"	18"			
7' 0"	21"	21"	21"	21"				
6' 6"	21"	18"	18"	21"				

**TABLE 3**

DOOR HEIGHT	TRACK ATTACHMENT							SPLICE
	A	B	C	D	E	F	G	
6' 6"	10"	21"	38"	58"				70"
7'	10"	21"	38"	58"				76"
7' 6"	10"	21"	38"	58"	78"			82"
8'	10"	21"	38"	58"	78"			88"
8' 6"	10"	21"	38"	58"	78"			94"
9'	10"	21"	38"	58"	78"			100"
9' 6"	10"	21"	38"	58"	78"	98"		106"
10'	10"	21"	38"	58"	78"	98"		112"
10' 6"	10"	21"	38"	58"	78"	98"		118"
11'	10"	21"	38"	58"	78"	98"	118"	124"
11' 6"	10"	21"	38"	58"	78"	98"	118"	130"
12'	10"	21"	38"	58"	78"	98"	118"	136"
12' 6"	10"	21"	38"	58"	78"	98"	118"	142"
13'	10"	21"	38"	58"	78"	98"	118"	148"
13' 6"	10"	21"	38"	58"	78"	98"	118"	154"
14'	10"	21"	38"	58"	78"	98"	118"	160"

JAMB BRACKET SPACING ALLOWS +/- 2" WITH SYP OR SPF NO. 2 OR BETTER ONLY

**TABLE 4**

Section Width (ft)	Panel Type	Center Stile Locations (Measured from Left Edge)					Max Design Loads Allowed	
		1st (in)	2st (in)	3rd (in)	4th (in)	5th (in)	Positive (PSF)	Negative (PSF)
16' 2"	Short	50.27	73.64	97.00	120.36	143.73	20.2	22.9
16' 2"	Long	51.17	74.08	97.00	119.92	142.83	20.2	22.9
16' 2"	Oak Summit	48.75	72.88	97.00	121.13	145.25	20.2	22.9
16' 4"	Short	51.27	74.64	98.00	121.36	144.73	20.0	22.7
16' 4"	Long	52.17	75.08	98.00	120.92	143.83	20.0	22.6
16' 4"	Oak Summit	49.08	73.54	98.00	122.46	146.92	20.0	22.7
16' 6"	Short	52.27	75.64	99.00	122.36	145.73	19.8	22.4
16' 6"	Long	51.34	75.17	99.00	122.83	146.66	19.8	22.4
16' 6"	Oak Summit	49.42	74.21	99.00	123.79	148.59	19.8	22.4
16' 8"	Short	51.34	75.67	100.00	124.33	148.66	19.6	22.2
16' 8"	Long	52.20	76.10	100.00	123.90	147.80	19.6	22.2
16' 8"	Oak Summit	49.92	74.96	100.00	125.04	150.09	19.6	22.2
16' 10"	Short	51.50	76.25	101.00	125.75	150.50	19.4	22.0
16' 10"	Long	53.20	77.10	101.00	124.90	148.80	19.4	22.0
16' 10"	Oak Summit	50.15	75.57	101.00	126.29	151.59	19.4	22.0
17' 0"	Short	53.34	77.67	102.00	126.33	150.66	19.2	21.8
17' 0"	Long	54.20	78.10	102.00	125.90	149.80	19.2	21.7
17' 0"	Oak Summit	50.92	76.46	102.00	127.54	153.09	19.2	21.8
17' 2"	Short	53.00	78.00	103.00	128.00	153.00	19.0	21.6
17' 2"	Long	55.20	79.10	103.00	126.90	150.80	19.0	21.5
17' 2"	Oak Summit	51.42	77.21	103.00	128.79	154.59	19.0	21.6
17' 4"	Short	54.00	79.00	104.00	129.00	154.00	18.9	21.3
17' 4"	Long	56.20	80.10	104.00	127.90	151.80	18.7	21.2
17' 4"	Oak Summit	51.92	77.96	104.00	130.04	156.09	18.9	21.3
17' 6"	Short	55.00	80.00	105.00	130.00	155.00	18.7	21.1
17' 6"	Long	57.20	81.10	105.00	128.90	152.80	18.5	20.9
17' 6"	Oak Summit	52.42	78.71	105.00	131.29	157.59	18.7	21.1
17' 8"	Short	54.80	80.40	106.00	131.60	157.20	18.5	20.9
17' 8"	Long	55.80	80.90	106.00	131.10	156.20	18.5	20.9
17' 8"	Oak Summit	52.92	79.46	106.00	132.54	159.09	18.5	20.9
17' 10"	Short	55.80	81.40	107.00	132.60	158.20	18.3	20.7
17' 10"	Long	56.25	81.63	107.00	132.38	157.75	18.3	20.7
17' 10"	Oak Summit	53.42	80.21	107.00	133.79	160.59	18.3	20.7
18' 0"	Short	57.25	82.63	108.00	133.38	158.75	18.2	20.6
18' 0"	Long	57.80	82.90	108.00	133.10	158.20	18.2	20.6
18' 0"	Oak Summit	53.92	80.96	108.00	135.04	162.09	18.2	20.6

REV	DESCRIPTION OF REVISIONS	DATE	BY
A	UPDATED BOTTOM BRACKET INFORMATION ADDED OAKSUMMIT AND GLAZING OPTIONS	08/30/05	DLJ
B	REVISED NOTE 6	09/02/08	DLJ
C	WIND SPEED TABLE & TRACK CONFIGURATIONS	04/20/12	RLR
D	ADDED JAMB BRACKET	12/18/12	RLR
E	ADDED LONG PANEL GLAZING OPTION/ADDED HINGES	02/08/17	RLR

MAX SIZE  
18' WIDTH  
14' HEIGHT  
(DOOR HEIGHT SUBJECT TO WEIGHT LIMITATIONS)

DESIGN LOADS  
+18.2 PSF  
-20.6 PSF

TEST LOADS  
(1.5 x DESIGN LOADS)  
+27.3 PSF  
-30.9 PSF

Thomas L. Shelmerdine, PE (TX PE #85829)  
Structural Solutions, PA (TX Firm #F-004065)

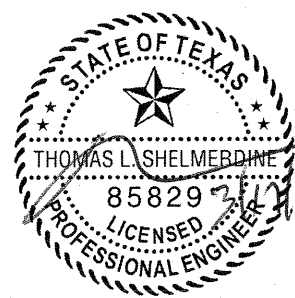

TX

5921-G W. Friendly Ave., Greensboro, NC 27410

**Amarr**  
ENTREMATIc

MODEL #650 AMARR OAK SUMMIT 1000, 2000  
MODEL #600 AMARR STRATFORD 1000, 2000  
MODEL #950 HERITAGE 1000, 2000  
Short, Long, Flush & Oak Summit Panel's

SIZE	DRAWN BY DLJ	DATE 09/10/03	DRAWING NUMBER
B	CHECKED BY AAE	DATE 09/10/03	IRC-6018-110-15

ENTREMATIc  
165 CARRIAGE COURT WINSTON-SALEM, N.C. 27105

SHEET 3 OF 3