

INSIDE ELEVATION  
N.T.S.

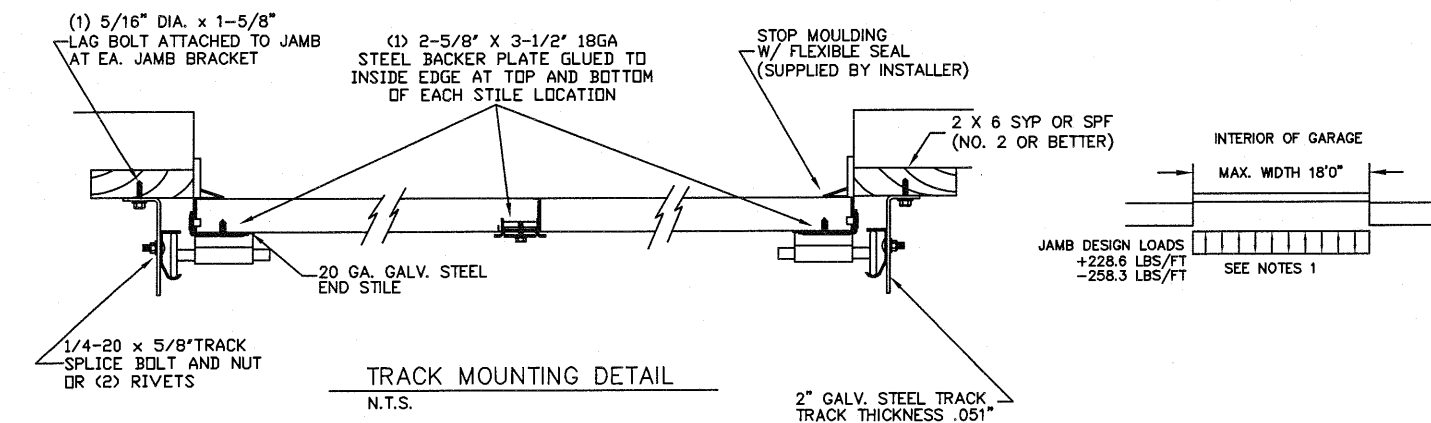

- SPECIFICATIONS AND NOTES**
- DOORS AND HARDWARE WILL BE DESIGNED, MANUFACTURED AND INSTALLED WITH STANDARDS AS SET FORTH BY DASMA. EACH VERTICAL JAMBS RECEIVES MAXIMUM DESIGN LOADS OF: +228.6 LBS/FT & -258.3 LBS/FT
  - DOOR SECTIONS SHALL BE 24 GA. MIN. (.0216") ROLLED FORMED LIGHT COMMERCIAL QUALITY
  - SUPPORTING STRUCTURAL ELEMENTS SHALL BE DESIGNED BY A REGISTERED PROFESSIONAL ENGINEER FOR WIND LOADS INDICATED ON THIS DRAWING IN ADDITION TO OTHER LOADINGS.

THE METHOD OF TESTING WAS IN SUBSTANTIAL CONFORMANCE WITH THE PROCEDURE DESCRIBED IN DASMA 108. THE PRESSURES SHOWN ON THE DRAWINGS WERE CALCULATED USING ASCE 7-98/02/05 WITH THE FOLLOWING PARAMETERS (5 FEET OF DOOR WIDTH IN THE END ZONE, ROOF AT ANY SLOPE, AND I=1.0):

WIND SPEED (MPH)	130	118	112	107	103
EXPOSURE LEVEL	B	C	C	D	D
MEAN ROOF HEIGHT	30'	15'	25'	15'	25'

SECTION A-A (SIDE VIEW)  
N.T.S.

REV	DESCRIPTION OF REVISIONS	DATE	BY

MAX SIZE 18' WIDTH 14' HEIGHT (DOOR HEIGHT SUBJECT TO WEIGHT LIMITATIONS)

DESIGN LOADS  
+25.4 PSF  
-28.7 PSF

TEST LOADS (1.5 x DESIGN LOADS)  
+38.1 PSF  
-43.1 PSF

Thomas L. Shelmerdine, PE (TX PE #85829) Structural Solutions, PA (TX Firm #F-004063)

STATE OF TEXAS  
THOMAS L. SHELMERDINE  
85829  
LICENSED PROFESSIONAL ENGINEER  
TX

Amarr  
ENTRE/MATIC  
165 CARRIAGE COURT WINSTON-SALEM, N.C. 27105

MODEL #1200 HERITAGE 3000  
MODEL #1200 OAK SUMMIT 3000  
SHORT, LONG, FLUSH & OAK SUMMIT PANELS

SIZE	DRAWN BY	RLR	DATE	07/10/14	DRAWING NUMBER
B	CHECKED BY		DATE		IRC-1218-130-24

SHEET 1 OF 3

9321-G.W. Friendly Ave., Greensboro, NC 27410

OPTIONAL SHORT AND LONG PANEL GLAZING LAYOUTS  
GLAZING MEETS ASTM E1300-04

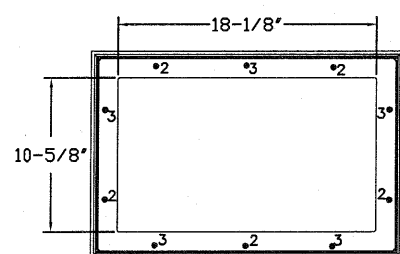
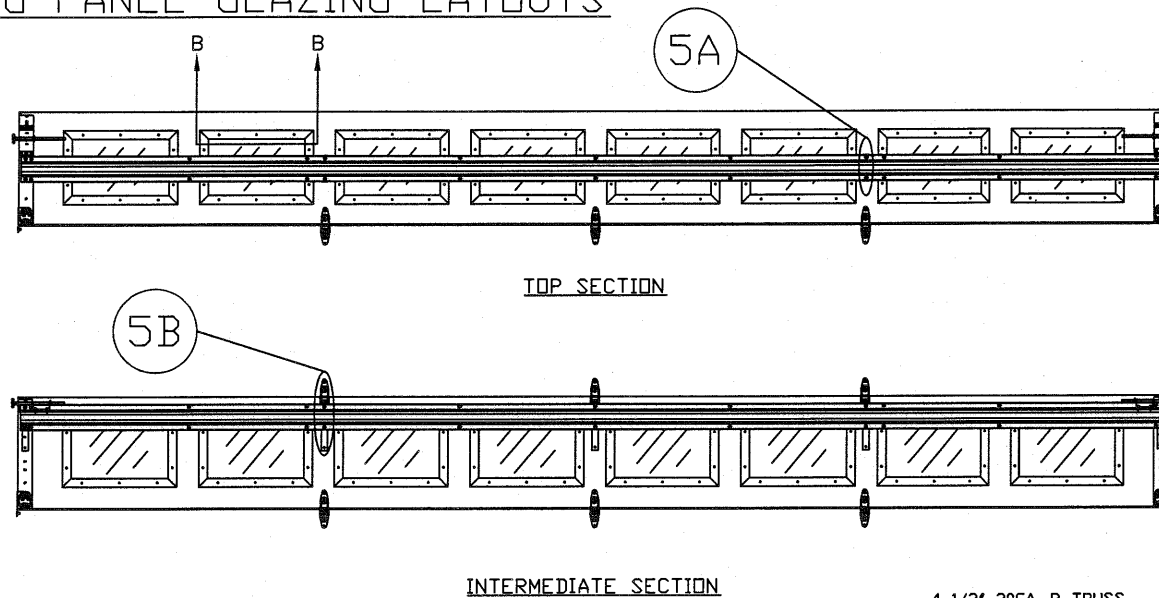
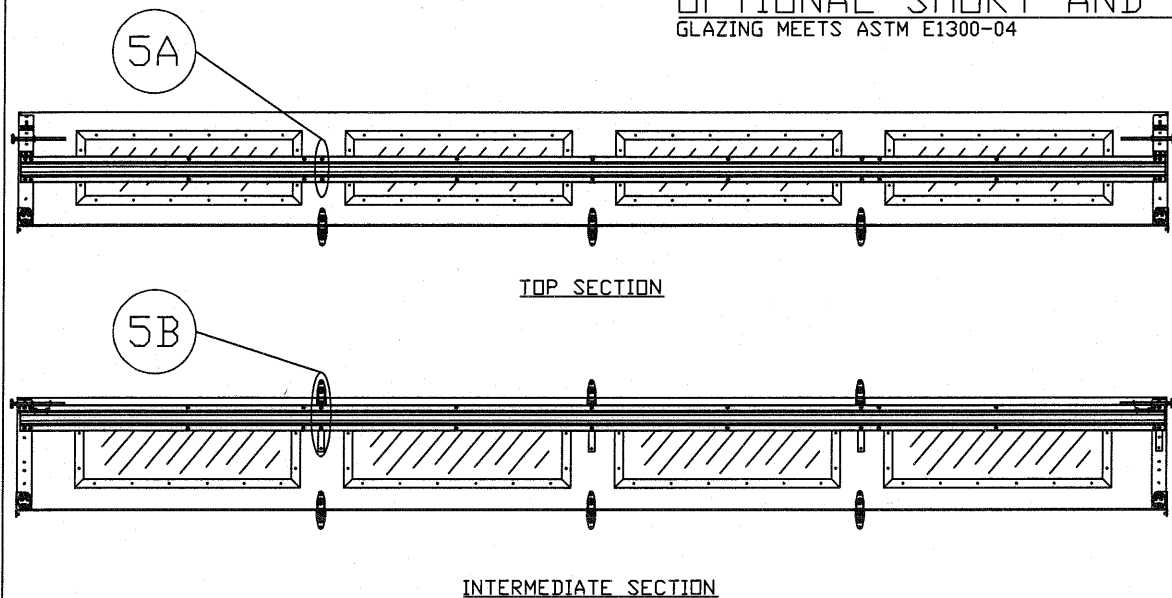

SHORT PANEL GLAZING FASTENER DETAIL  
N.T.S.

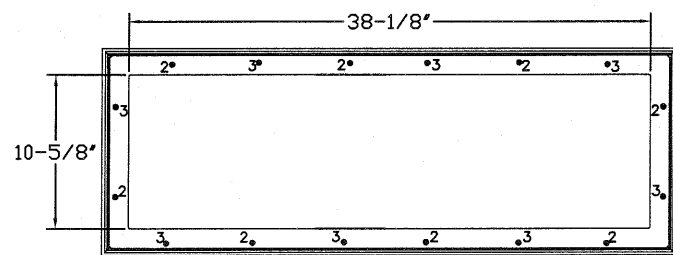

LONG PANEL GLAZING FASTENER DETAIL  
N.T.S.

4 1/2" X 20 GA R TRUSS  
ATTACHED W/ (2) 1/4" X 3/4"  
HEX HEAD SCREWS PER STILE

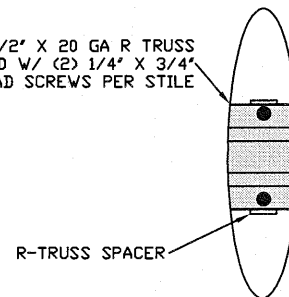

R-TRUSS SPACER  
N.T.S. 5A

4 1/2" 20GA. R-TRUSS  
ATTACHED W/ (2) 1/4" X  
3/4" HEX HEAD SCREWS  
AT EACH CENTER STILE

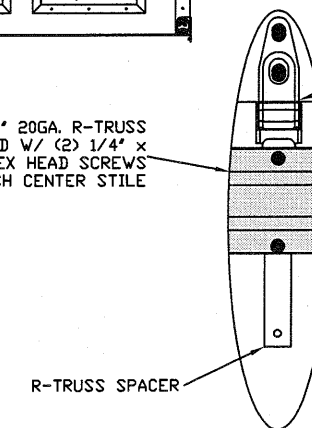

R-TRUSS SPACER  
N.T.S. 5B

14GA. DURASAFE  
CENTER HINGE ATTACHED  
W/ (4) 1/4" X 3/4"  
HEX HEAD SCREWS

WOOD JAMB ATTACHMENT TO STRUCTURE

**2 X 6 VERTICAL JAMB ATTACHMENT TO WOOD FRAME STRUCTURE**  
5/16" X 3" LAG SCREWS STARTING 6" FROM ENDS THEN 20" O.C. (1 1/2" EMBEDMENT)

**2 X 6 VERTICAL JAMB ATTACHMENT TO 2,000 PSI CONCRETE**  
HILTI KWIK BOLT 3/8" X 4" STARTING 6" FROM ENDS THEN 24" O.C. (2 1/2" EMBEDMENT)  
HILTI SLEEVE ANCHOR 3/8" X 2-3/4" STARTING 6" FROM ENDS THEN 18" O.C. (1 1/4" EMBEDMENT)  
ITW/RAMSET REDHEAD (TRU-BOLT) 3/8" X 4" STARTING 6" FROM ENDS THEN 24" O.C. (2 1/2" EMBEDMENT)

**2 X 6 VERTICAL JAMB ATTACHMENT TO HOLLOW C-90 BLOCK**  
SIMPSON 1/4" X 3" TITEN SCREWS STARTING 6" FROM ENDS, USE PAIRS OF FASTENERS (3" APART) AT 8" O.C. (1 1/2" EMBEDMENT)  
HILTI 1/4" X 2-3/4" KWIK-CON II+ SCREWS STARTING 6" FROM ENDS, USE PAIRS OF FASTENERS (3" APART) AT 8" O.C. (1 1/4" EMBEDMENT)

**2 X 6 VERTICAL JAMB ATTACHMENT TO GROUTED C-90 BLOCK (2000 PSI GROUT)**  
HILTI SLEEVE ANCHOR 3/8" X 2-3/4" STARTING 6" FROM ENDS THEN 22" O.C. (1 1/4" EMBEDMENT) (OR, USE FASTENERS FOR HOLLOW C-90 BLOCK)

\*LAGS AND BOLTS CAN BE COUNTERSUNK TO PROVIDE A FLUSH MOUNTING SURFACE.  
\*PREPARATION OF WOOD JAMBS BY OTHERS

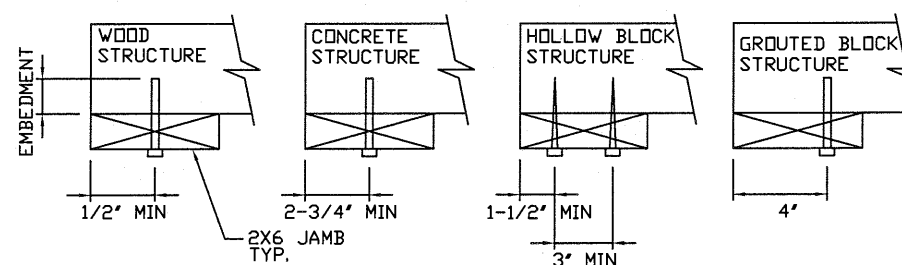

GLAZING OPTION CROSS SECTION

GLAZING NOT AVAILABLE IN WIND-BORNE DEBRIS REGION

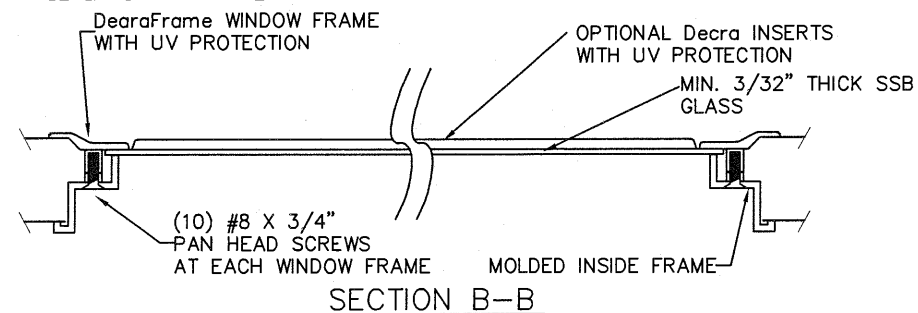

REV	DESCRIPTION OF REVISIONS	DATE	BY

MAX SIZE  
18' WIDTH  
14' HEIGHT  
(DOOR HEIGHT SUBJECT TO WEIGHT LIMITATIONS)

DESIGN LOADS  
+25.4 PSF  
-28.7 PSF

TEST LOADS  
(1.5 x DESIGN LOADS)  
+38.1 PSF  
-43.1 PSF

Thomas L. Shelmerdine, PE (TX PE #85829)  
Structural Solutions, PA (TX Firm #F-004063)

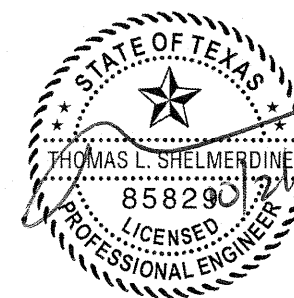

TX

**Amarr**

ENTREMATIC  
165 CARRIAGE COURT WINSTON-SALEM, N.C. 27105

MODEL #1200 HERITAGE 3000  
MODEL #1200 OAK SUMMIT 3000  
SHORT, LONG, FLUSH & OAK SUMMIT PANELS

SIZE	DRAWN BY	RLR	DATE	07/10/14	DRAWING NUMBER
B	CHECKED BY	DATE			IRC-1218-130-24

SHEET 2 OF 3

5921-G W. Friendly Ave., Greensboro, NC 27410

TABLE 1

DOOR HEIGHT	SECTION HEIGHTS							
	Btm	#2	#3	#4	#5	#6	#7	#8
14' 0"	21"	21"	21"	21"	21"	21"	21"	21"
13' 6"	21"	21"	21"	21"	21"	18"	18"	21"
13' 0"	21"	21"	21"	18"	18"	18"	18"	21"
12' 6"	21"	18"	18"	18"	18"	18"	18"	21"
12' 0"	21"	21"	21"	21"	21"	18"	21"	
11' 6"	21"	21"	21"	18"	18"	18"	21"	
11' 0"	21"	18"	18"	18"	18"	18"	21"	
10' 6"	21"	21"	21"	21"	21"	21"		
10' 0"	21"	21"	21"	18"	18"	21"		
9' 6"	21"	18"	18"	18"	18"	21"		
9' 0"	18"	18"	18"	18"	18"	18"		
8' 6"	21"	21"	21"	18"	21"			
8' 0"	21"	18"	18"	18"	21"			
7' 6"	18"	18"	18"	18"	18"			
7' 0"	21"	21"	21"	21"				
6' 6"	21"	18"	18"	21"				

TABLE 2

DOOR HEIGHT	TRACK ATTACHMENT								SPLICE
	A	B	C	D	E	F	G	H	
6' 6"	10"	21"	42"	63"					70"
7'	10"	21"	42"	63"					76"
7' 6"	10"	21"	42"	63"					82"
8'	10"	21"	42"	63"					88"
8' 6"	10"	21"	42"	63"	84"				94"
9'	10"	21"	42"	63"	84"				100"
9' 6"	10"	21"	42"	63"	84"				106"
10'	10"	21"	42"	63"	84"	105"			112"
10' 6"	10"	21"	42"	63"	84"	105"			118"
11'	10"	21"	42"	63"	84"	105"			124"
11' 6"	10"	21"	42"	63"	84"	105"			130"
12'	10"	21"	42"	63"	84"	105"	126"		136"
12' 6"	10"	21"	42"	63"	84"	105"	126"		142"
13'	10"	21"	42"	63"	84"	105"	126"		148"
13' 6"	10"	21"	42"	63"	84"	105"	126"	147"	154"
14'	10"	21"	42"	63"	84"	105"	126"	147"	160"

ALL TRACK ATTACHMENT SPACING +/- 1/4" ALLOWED WITH SYP OR SPF NO. 2 OR BETTER ONLY

TABLE 3

Section Width (ft)	Panel Type	Max Design Loads Allowed	
		Positive (PSF)	Negative (PSF)
16' 2"	Short	28.1	31.8
16' 2"	Long	28.1	31.8
16' 2"	Oak Summit	28.1	31.8
16' 4"	Short	27.9	31.5
16' 4"	Long	27.9	31.5
16' 4"	Oak Summit	27.9	31.5
16' 6"	Short	27.6	31.2
16' 6"	Long	27.6	31.2
16' 6"	Oak Summit	27.6	31.2
16' 8"	Short	27.3	30.8
16' 8"	Long	27.3	30.8
16' 8"	Oak Summit	27.3	30.8
16' 10"	Short	27.0	30.5
16' 10"	Long	27.0	30.5
16' 10"	Oak Summit	27.0	30.5
17' 0"	Short	26.8	30.2
17' 0"	Long	26.8	30.2
17' 0"	Oak Summit	26.8	30.2
17' 2"	Short	26.5	29.9
17' 2"	Long	26.5	29.9
17' 2"	Oak Summit	26.5	29.9
17' 4"	Short	26.2	29.7
17' 4"	Long	26.2	29.7
17' 4"	Oak Summit	26.2	29.7
17' 6"	Short	26.0	29.4
17' 6"	Long	26.0	29.4
17' 6"	Oak Summit	26.0	29.4
17' 8"	Short	25.7	29.1
17' 8"	Long	25.7	29.1
17' 8"	Oak Summit	25.7	29.1
17' 10"	Short	25.5	28.8
17' 10"	Long	25.5	28.8
17' 10"	Oak Summit	25.5	28.8
18' 0"	Short	25.4	28.7
18' 0"	Long	25.4	28.7
18' 0"	Oak Summit	25.3	28.6

TABLE 4

Section Width (ft)	Panel Type	Center Stile Locations (Measured from Left Edge)		
		1st (in)	3rd (in)	5th (in)
16' 2"	Short	50.27	97.00	143.73
16' 2"	Long	51.17	97.00	142.83
16' 2"	Oak Summit	48.75	97.00	145.25
16' 4"	Short	51.27	98.00	144.73
16' 4"	Long	52.17	98.00	143.83
16' 4"	Oak Summit	49.08	98.00	146.92
16' 6"	Short	52.27	99.00	145.73
16' 6"	Long	51.34	99.00	146.66
16' 6"	Oak Summit	49.42	99.00	148.59
16' 8"	Short	51.34	100.00	148.66
16' 8"	Long	52.20	100.00	147.80
16' 8"	Oak Summit	49.92	100.00	150.09
16' 10"	Short	51.50	101.00	150.50
16' 10"	Long	53.20	101.00	148.80
16' 10"	Oak Summit	50.15	101.00	151.59
17' 0"	Short	53.34	102.00	150.66
17' 0"	Long	54.20	102.00	149.80
17' 0"	Oak Summit	50.92	102.00	153.09
17' 2"	Short	53.00	103.00	153.00
17' 2"	Long	55.20	103.00	150.80
17' 2"	Oak Summit	51.42	103.00	154.59
17' 4"	Short	54.00	104.00	154.00
17' 4"	Long	56.20	104.00	151.80
17' 4"	Oak Summit	51.92	104.00	156.09
17' 6"	Short	55.00	105.00	155.00
17' 6"	Long	57.20	105.00	152.80
17' 6"	Oak Summit	52.42	105.00	157.59
17' 8"	Short	54.80	106.00	157.20
17' 8"	Long	55.80	106.00	156.20
17' 8"	Oak Summit	52.92	106.00	159.09
17' 10"	Short	55.80	107.00	158.20
17' 10"	Long	56.25	107.00	157.75
17' 10"	Oak Summit	53.42	107.00	160.59
18' 0"	Short	57.25	108.00	158.75
18' 0"	Long	57.80	108.00	158.20
18' 0"	Oak Summit	53.92	108.00	162.09

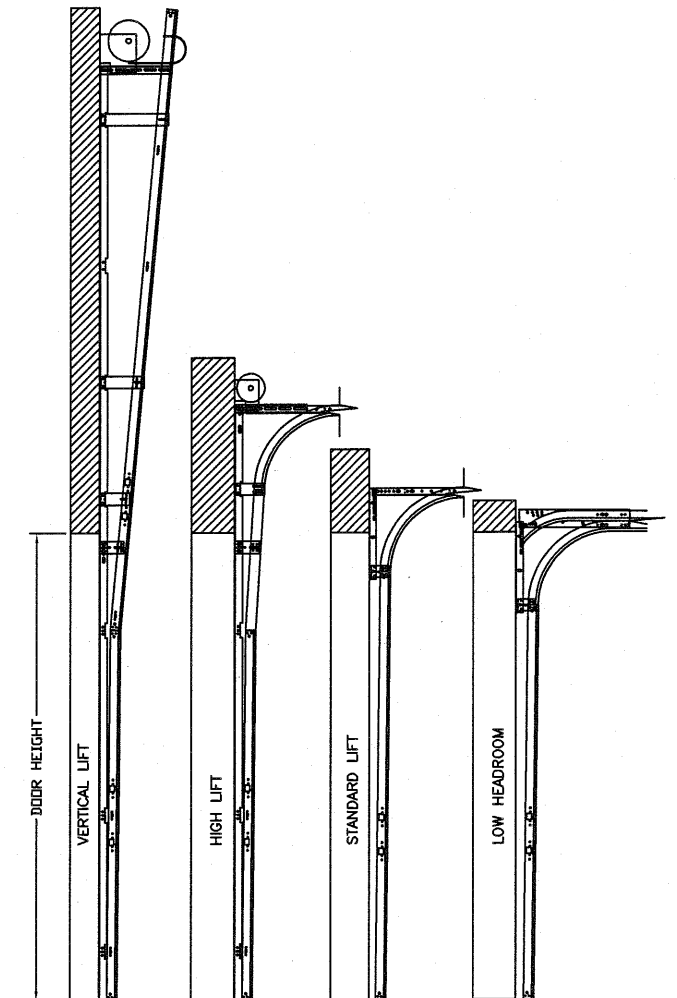

AVAILABLE TRACK CONFIGURATIONS N.T.S.

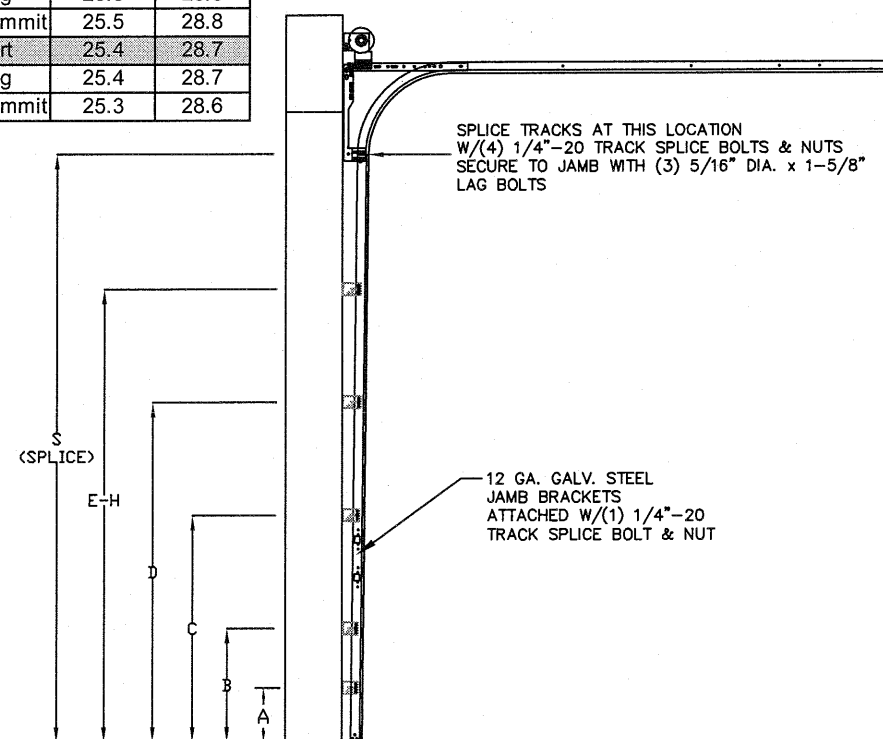

TRACK CONFIGURATION FOR 6'6" UP TO 14' TALL DOORS (SEE TABLE 2) N.T.S.

REV	DESCRIPTION OF REVISIONS	DATE	BY

MAX SIZE 18' WIDTH 14' HEIGHT (DOOR HEIGHT SUBJECT TO WEIGHT LIMITATIONS)

DESIGN LOADS +25.4 PSF -28.7 PSF

TEST LOADS (1.5 x DESIGN LOADS) +38.1 PSF -43.1 PSF

Thomas L. Shelmerdine, PE (TX PE #85829) Structural Solutions, PA (TX Firm #F-004063)

STATE OF TEXAS  
THOMAS L. SHELMERDINE  
85829  
LICENSED PROFESSIONAL ENGINEER  
TX

Amarr  
ENTREMATIC  
165 CARRIAGE COURT WINSTON-SALEM, N.C. 27105

MODEL #1200 HERITAGE 3000  
MODEL #1200 OAK SUMMIT 3000  
SHORT, LONG, FLUSH & OAK SUMMIT PANELS

SIZE	DRAWN BY	RLR	DATE	07/10/14	DRAWING NUMBER
B	CHECKED BY		DATE		IRC-1218-130-24

SHEET 3 OF 3