

TYPICAL TOP FIXTURES
N.T.S. 1

TYPICAL CENTER HINGE
N.T.S. 2

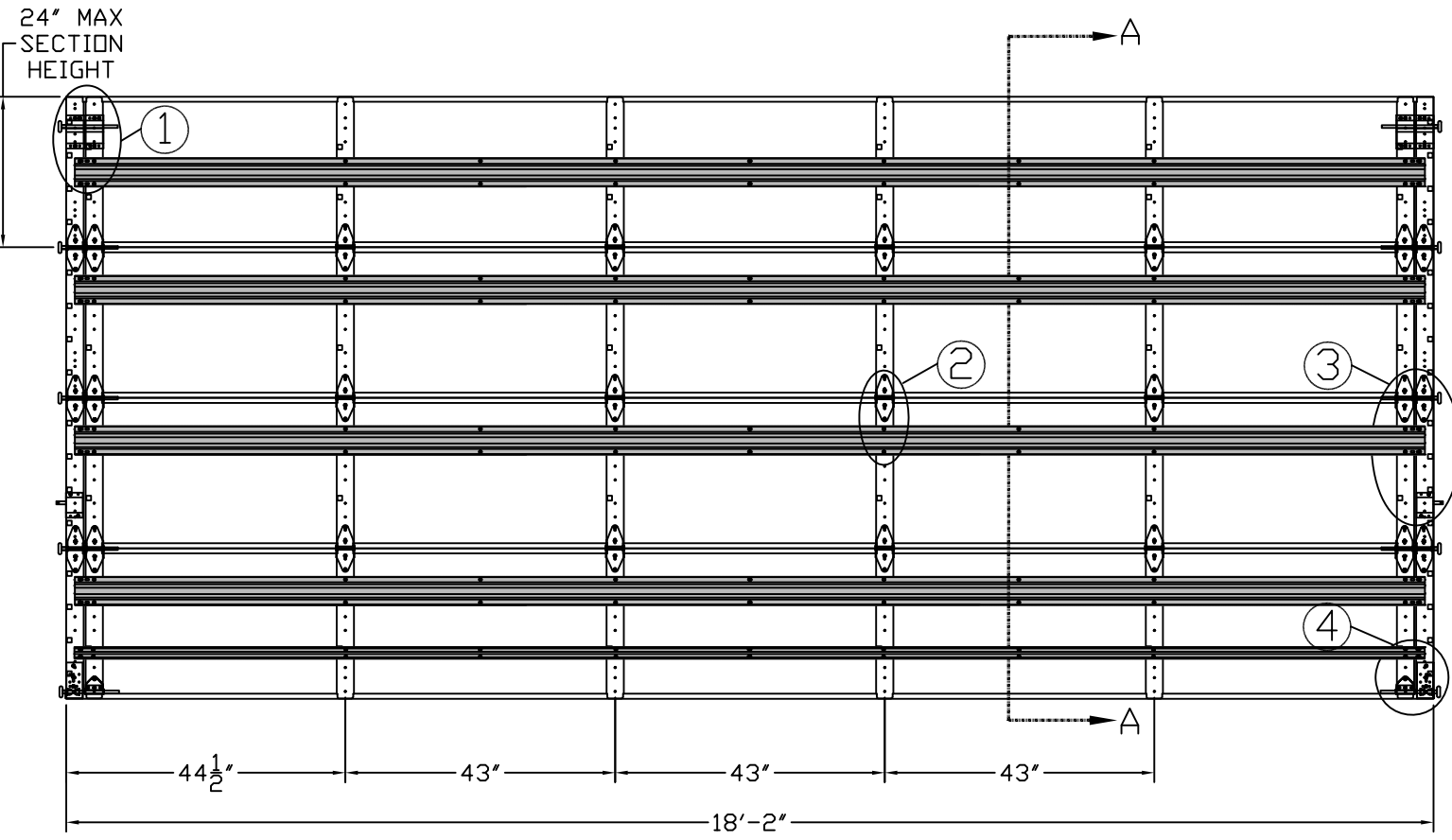

INSIDE ELEVATION
N.T.S.

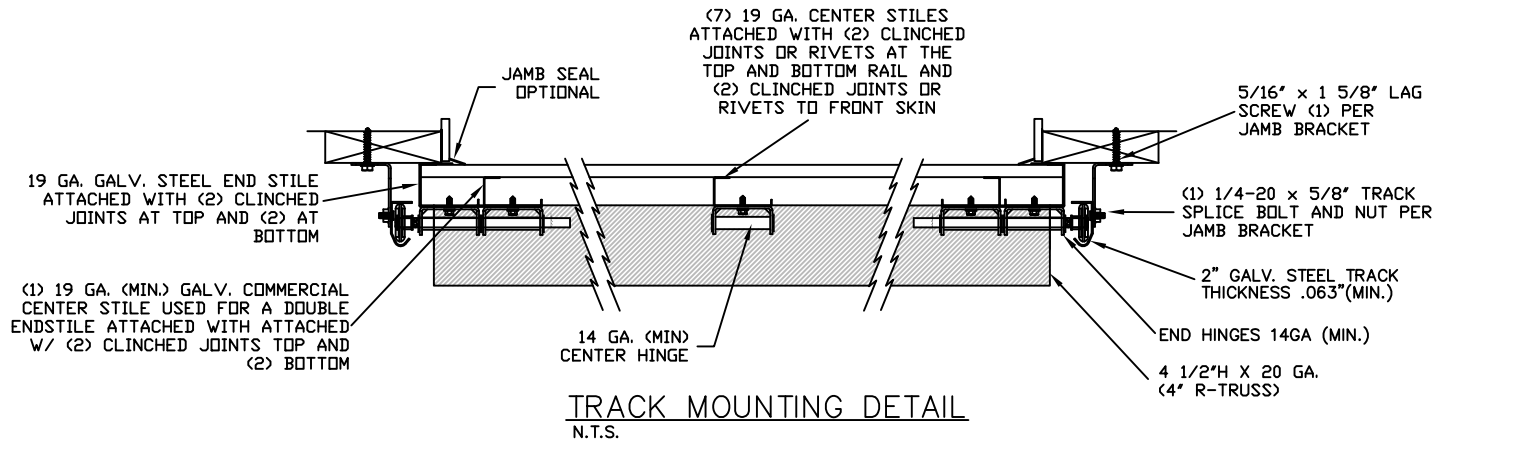

TRACK MOUNTING DETAIL
N.T.S.

EDGE OF DOOR 1" OVERLAP ON EACH SIDE

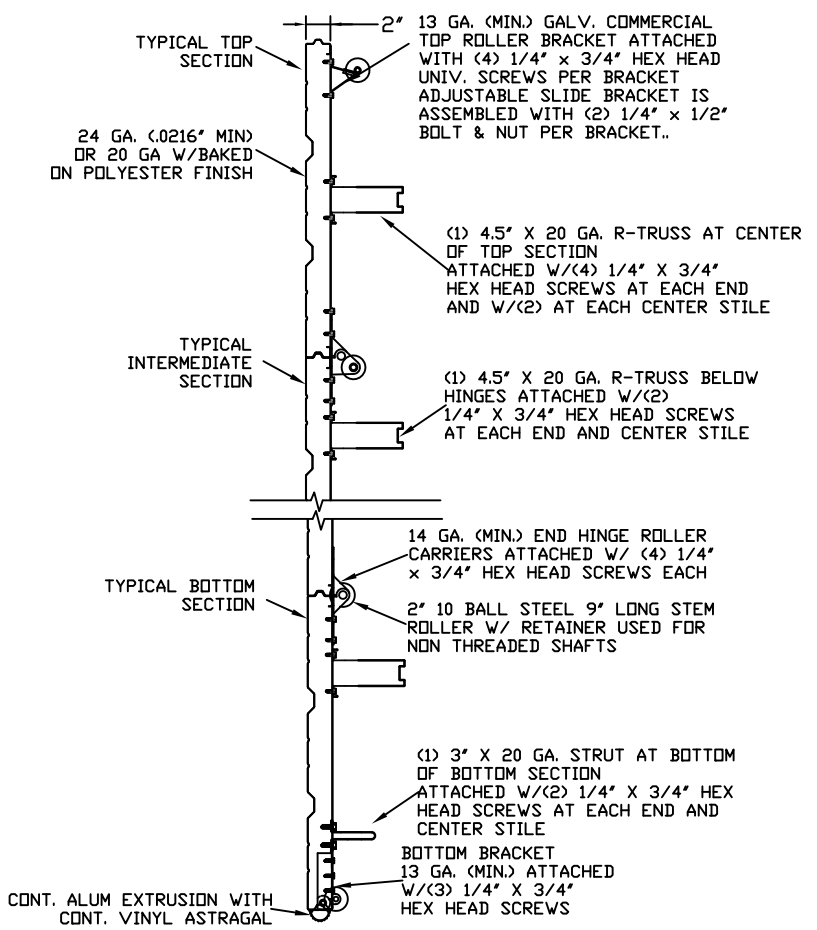

SECTION A-A (SIDE VIEW)

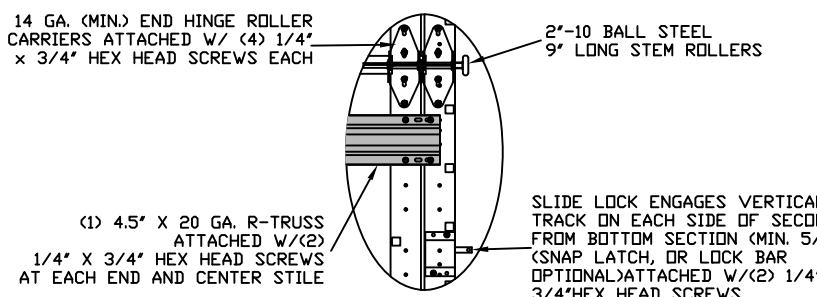

TYPICAL END HINGE
N.T.S. 3

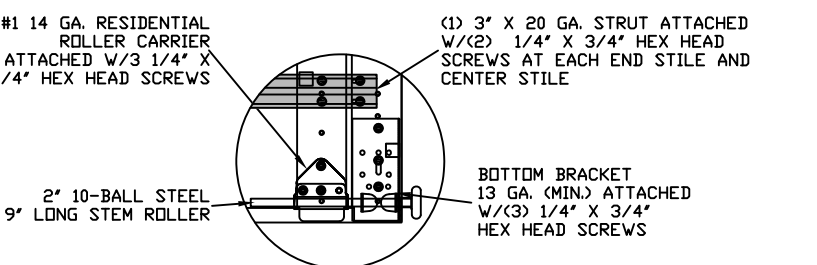

TYPICAL BOTTOM BRACKET
N.T.S. 4

SPECIFICATIONS

1. ALL THE LOAD FROM THE DOOR IS TRANSFERRED TO THE VERTICAL TRACK, FROM THE TRACK THE LOAD IS TRANSFERRED TO THE VERTICAL JAMBS. THE HORIZONTAL JAMB OR HEADER RECEIVES NO PORTION OF THE LOAD TRANSFERRED FROM THE DOOR
2. EACH VERTICAL JAMBS RECEIVES MAXIMUM DESIGN LOADS OF: +179.1 LBS/FT & -201.6 LBS/FT
3. DOOR AND HARDWARE WILL BE DESIGNED, MANUFACTURED AND INSTALLED WITH STANDARDS AS SET FORTH BY DASMA.
4. DOOR SECTIONS SHALL BE 24 GA. (.0216) MIN. EXTERIOR SKIN ROLLFORMED, W/ BAKED ON POLYESTER FINISH
5. DOORS UP TO 24'0" HIGH USE (1) 4 1/2" R-TRUSS PER SECTION AND (1) 3" 20GA STRUT ON BOTTOM SECTION
6. SUPPORTING STRUCTURAL ELEMENTS SHALL BE DESIGNED BY A REGISTERED PROFESSIONAL ENGINEER FOR WIND LOADS INDICATED ON THIS DRAWING IN ADDITION TO OTHER LOADINGS.

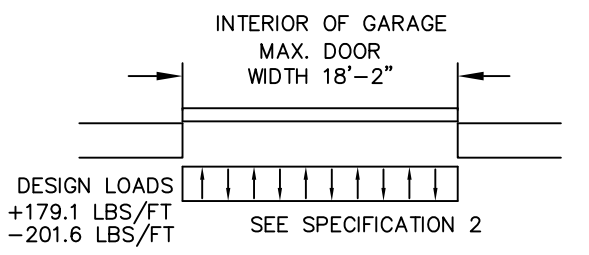

THE METHOD OF TESTING WAS IN SUBSTANTIAL CONFORMANCE WITH THE PROCEDURES DESCRIBED IN ASTM E330, ANSI/DASMA 108, ASTM E 1886, ASTM E 1996 AND ASTM F588. THE PRESSURES SHOWN ON THE DRAWINGS WERE CALCULATED USING ASCE 7-98/02/05 WITH THE FOLLOWING PARAMETERS (5 FEET OF DOOR WIDTH IN END ZONE, ROOF SLOPE 10° OR LESS):

WIND SPEED (MPH)	120	108	103	98	94
EXPOSURE LEVEL	B	C	C	D	D
MEAN ROOF HEIGHT	30'	15'	25'	15'	25'

REV	DESCRIPTION OF REVISIONS	DATE	BY
A	UPDATED WJATS, TCDTS, ADDED ASCE MPH DETAIL	4/26/12	RLR

MAX SIZE
18'2" x 24'
DESIGN LOADS
+19.9 PSF
-22.4 PSF
TEST LOADS
+29.9 PSF
-33.6 PSF



Amarr

165 CARRIAGE COURT WINSTON-SALEM, N.C. 27105 WWW.AMARR.COM

MODEL 2400 (24 GA)
MODEL 2000 (20 GA)

SIZE	DRAWN BY	SKW	DATE	10/15/07	DRAWING NUMBER
B	CHECKED BY	BHG	DATE	10/16/07	IBC-2418-120-24
ENGINEER: THOMAS L. SHELMERDINE P.E. LIC. No. 0048579					SHEET 1 OF 3

TRACK CONNECTION DIRECTLY TO STRUCTURE OPTIONS

ITW BUILDDEX 1/4"-14 X 3/4" SELF-TAPPING SCREWS (TEKS)

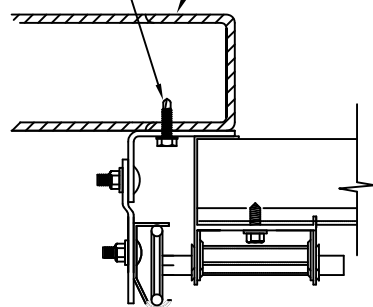

CLIP STYLE REVERSE ANGLE MOUNT SHOWN BRACKET, CONTINUOUS AND TAPERED ANGLE MOUNT AVAILABLE

12 GA. STEEL FRAMING
232 LBS./SCREW ALLOWABLE LOAD - 3" FROM ENDS AND 12" O.C.
REFER TO NOTES: 1, 2 AND 5

3/16" STEEL FRAMING
569 LBS./SCREW ALLOWABLE LOAD - 6" FROM ENDS AND 24" O.C.
REFER TO NOTES: 1, 2 AND 5

1/8" NDM X 1" LONG FILLET WELD (E60xx ELECTRODES MIN.)

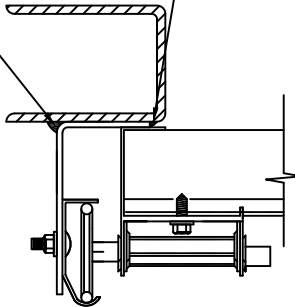

REVERSE ANGLE MOUNT SHOWN BRACKET, CONTINUOUS AND TAPERED ANGLE MOUNT AVAILABLE

STEEL FRAMING 12GA OR BETTER
1590 LBS./IN. ALLOWABLE LOAD - 6" FROM ENDS AND 24" O.C.
REFER TO NOTES: 1, 2, 5, 6, 7, 8 AND 9

2000 PSI MIN. CONCRETE

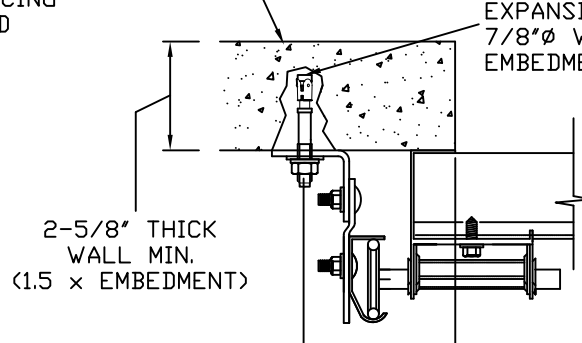

2-5/8" THICK WALL MIN. (1.5 x EMBEDMENT)

CLIP STYLE CONTINUOUS ANGLE MOUNT SHOWN BRACKET, REVERSE AND TAPERED ANGLE MOUNT AVAILABLE

2000 PSI CONCRETE OR GREATER
351 LBS./EXPANSION ANCHOR ALLOWABLE LOAD - 6" FROM ENDS AND 18" O.C.
REFER TO NOTES: 1, 2, 3, 4 AND 5

SIMPSON STRONG-TIE 3/8"Ø WEDGE-ALL EXPANSION ANCHOR WITH 7/8"Ø WASHER, 1-3/4" MIN. EMBEDMENT

2000 PSI MIN. CONCRETE

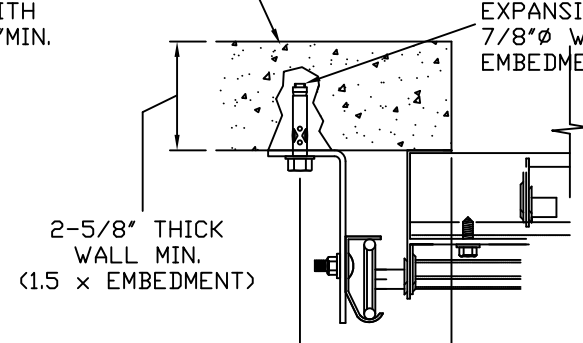

2-5/8" THICK WALL MIN. (1.5 x EMBEDMENT)

CONTINUOUS ANGLE MOUNT SHOWN BRACKET, CONTINUOUS AND TAPERED ANGLE MOUNT AVAILABLE

2000 PSI CONCRETE OR GREATER
336 LBS./EXPANSION ANCHOR ALLOWABLE LOAD - 6" FROM ENDS AND 18" O.C.
REFER TO NOTES: 1, 2, 3, 4 AND 5

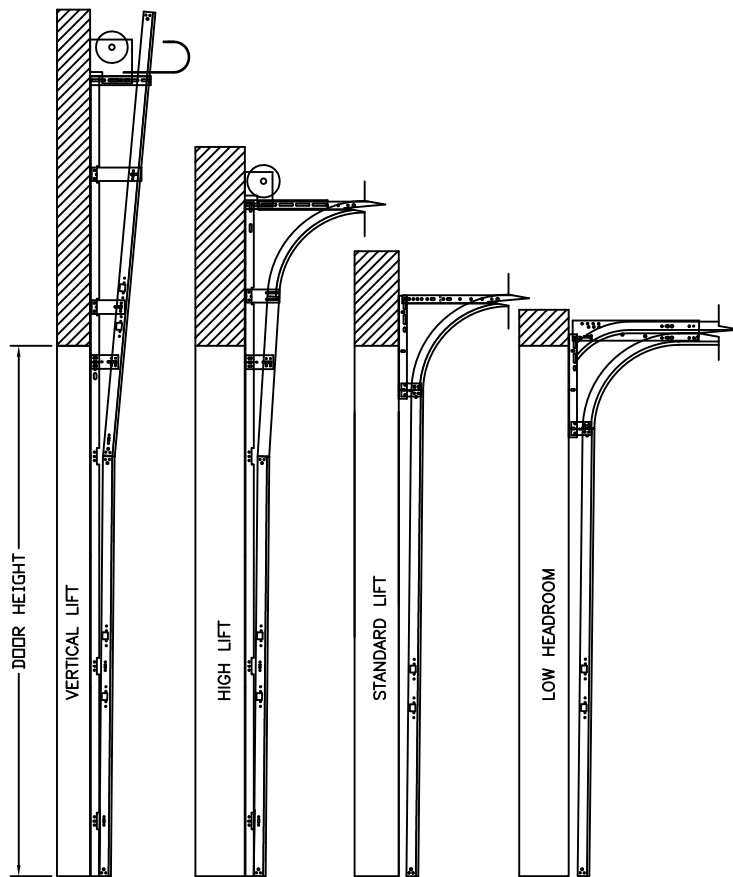

2" (.063 MIN.) OR 3" (12 GA. MIN.) VERTICAL TRACK

AVAILABLE TRACK CONFIGURATIONS
N.T.S.

NOTES:

- ANCHORS TO BE EVENLY SPACED BETWEEN THE HEADER AND FLOOR.
- FIRST (BOTTOM) ANCHOR STARTING AT NO MORE THAN HALF OF THE MAXIMUM ON-CENTER DISTANCE. HIGHEST ANCHOR INSTALLED AT LEAST AS HIGH AS THE DOOR OPENING.
- MIN. EDGE DISTANCE OF 3" REQUIRED.
- USE WASHERS PROVIDED BY THE ANCHOR MANUFACTURER.
- SUPPORTING STRUCTURAL ELEMENTS SHALL BE DESIGNED BY A REGISTERED PROFESSIONAL ENGINEER FOR WIND LOADS IN ADDITION TO OTHER LOADS.
- MOST GARAGE DOOR TRACK IS GALVANIZED STEEL. USE ALL NECESSARY PRECAUTIONS WHEN WELDING GALVANIZED STEEL.
- ALL WELDS SHOULD BE PERFORMED BY A CERTIFIED WELDER OR INSPECTED BY A CERTIFIED WELDING INSPECTOR TO VERIFY THE INTEGRITY OF THE WELD.
- FILLET WELDS TO HAVE A STRAIGHT OR CONVEX FACE SURFACE.
- TACK WELD TOE OF ANGLE AT SAME SPACING TO PREVENT ROTATION OF TRACK ANGLE.

TABLE 1

DOOR HEIGHT	TRACK ATTACHMENT											SPLICE S
	A	B	C	D	E	F	G	H	I	J	K	
7	10' 38"	*57"										76"
8	10' 34"	58"										88"
9	10' 34"	58"	82"									100"
10	10' 34"	58"	82"									112"
11'	10' 34"	58"	82"	106"								124"
12	10' 34"	58"	82"	106"								136"
13	10' 34"	58"	82"	106"	130"							148"
14	10' 34"	58"	82"	106"	130"							160"
15	10' 34"	58"	82"	106"	130"	154"						172"
16	10' 34"	58"	82"	106"	130"	154"						184"
17	10' 34"	58"	82"	106"	130"	154"	178"					196"
18	10' 34"	58"	82"	106"	130"	154"	178"					208"
19	10' 34"	58"	82"	106"	130"	154"	178"	202"				220"
20	10' 34"	58"	82"	106"	130"	154"	178"	202"				232"
21'	10' 34"	58"	82"	106"	130"	154"	178"	202"	226"			244"
22	10' 34"	58"	82"	106"	130"	154"	178"	202"	226"			256"
23	10' 34"	58"	82"	106"	130"	154"	178"	202"	226"	250"		268"
24	10' 34"	58"	82"	106"	130"	154"	178"	202"	226"	250"		280"

* Field Installed

REV	DESCRIPTION OF REVISIONS	DATE	BY
A	UPDATED WJATS, TCDTS, ADDED ASCE MPH DETAIL	4/26/12	RLR

MAX SIZE
18'2" x 24'
DESIGN LOADS
+19.9 PSF
-22.4 PSF
TEST LOADS
+29.9 PSF
-33.6 PSF



Amarr

165 CARRIAGE COURT WINSTON-SALEM, N.C. 27105 WWW.AMARR.COM

MODEL 2400 (24 GA)
MODEL 2000 (20 GA)

SIZE	DRAWN BY	SKW	DATE	10/15/07	DRAWING NUMBER
B	CHECKED BY	BHG	DATE	10/16/07	IBC-2418-120-24

ENGINEER: THOMAS L. SHELMERDINE P.E. LIC. No. 0048579 SHEET 2 OF 3

TABLE 2

Section Width		Center Stile Locations (Measured from Left Edge)					Max Design Loads Allowed	
(ft)	(in)	1st (in)	2nd (in)	3rd (in)	4th (in)	5th (in)	Positive (PSF)	Negative (PSF)
16'	4	50	74	98	122	146	22.1	24.9
16'	6	51	75	99	123	147	21.9	24.6
16'	8	52	76	100	124	148	21.6	24.4
16'	10	53	77	101	125	149	21.4	24.1
17'	0	39	81	123	165		20.7	23.3
17'	2	40	82	124	166		20.7	23.3
17'	4	41	83	125	167		20.7	23.3
17'	6	42	84	126	168		20.6	23.2
17'	8	43	85	127	169		20.4	23
17'	10	44	86	128	170		20.2	22.7
18'	0	43.5	86.5	129.5	172.5		20	22.6
18'	2	44.5	87.5	130.5	173.5		19.9	22.4

TRACK CONNECTION TO WOOD JAMB OPTIONS

FOR LAG SCREWS & BRACKET SPACING SEE TABLE 1

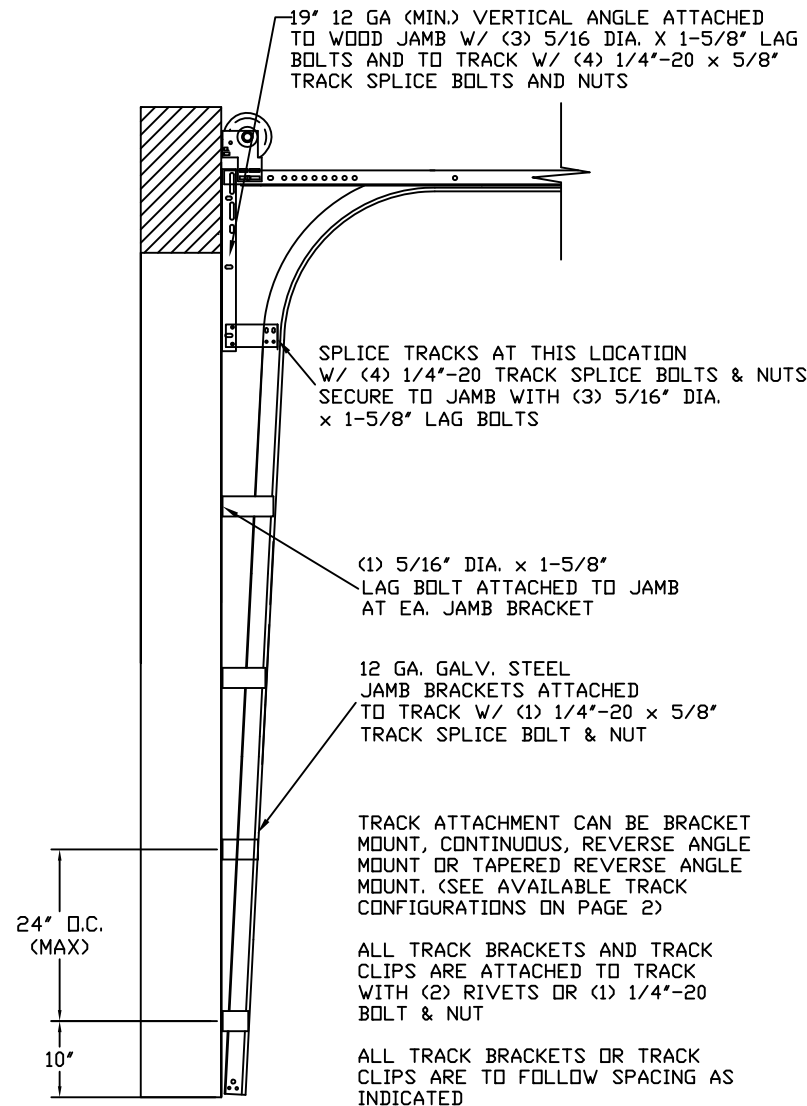
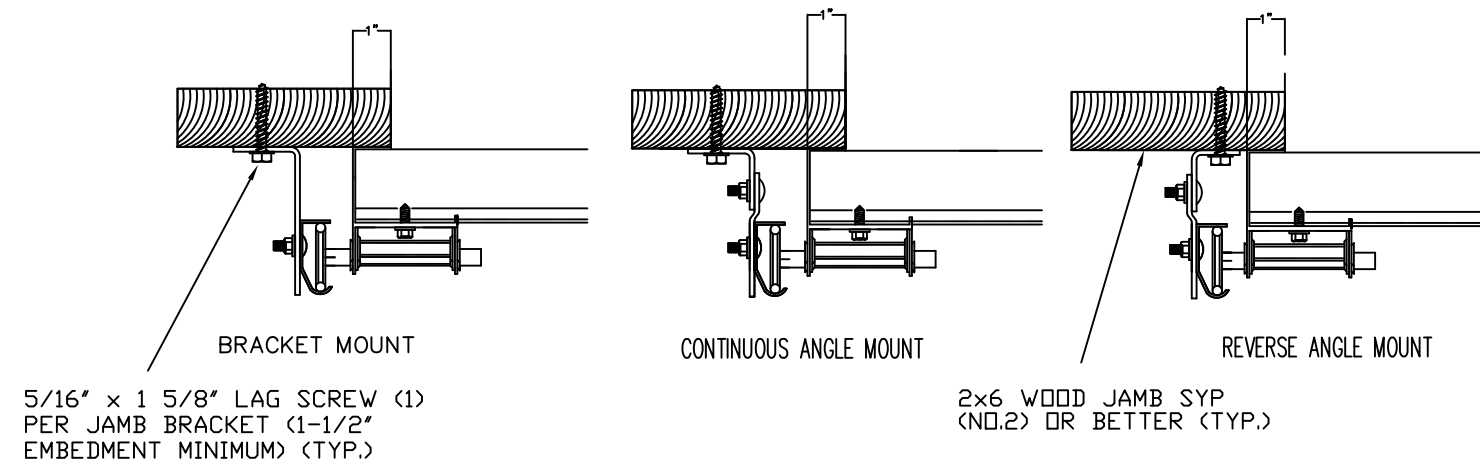

TRACK CONFIGURATION FOR 6' UP TO 24' TALL DOORS

WOOD JAMB ATTACHMENT TO STRUCTURE

2 X 6 VERTICAL JAMB ATTACHMENT TO WOOD FRAME STRUCTURE
5/16" X 3" LAG SCREWS STARTING 6" FROM ENDS THEN 24" O.C. (1 1/2" EMBEDMENT)

2 X 6 VERTICAL JAMB ATTACHMENT TO 2,000 PSI CONCRETE
HILTI KWIK BOLT 3/8" X 4" STARTING 6" FROM ENDS THEN 24" O.C. (2 1/2" EMBEDMENT)
HILTI SLEEVE ANCHOR 3/8" X 2-3/4" STARTING 6" FROM ENDS THEN 24" O.C. (1 1/4" EMBEDMENT)
ITW/RAMSET REDHEAD (TRU-BOLT) 3/8" X 4" STARTING 6" FROM ENDS THEN 24" O.C. (2 1/2" EMBEDMENT)

2 X 6 VERTICAL JAMB ATTACHMENT TO HOLLOW C-90 BLOCK
SIMPSON 1/4" X 3" TITEN SCREWS STARTING 6" FROM ENDS, USE PAIRS OF FASTENERS (3" APART) AT 16" O.C. (1 1/2" EMBEDMENT)
HILTI 1/4" X 2-3/4" KWIK-CON II+ SCREWS STARTING 6" FROM ENDS, USE PAIRS OF FASTENERS (3" APART) AT 16" O.C. (1 1/4" EMBEDMENT)

2 X 6 VERTICAL JAMB ATTACHMENT TO GROUTED C-90 BLOCK (2000 PSI GROUT)
HILTI SLEEVE ANCHOR 3/8" X 2-3/4" STARTING 6" FROM ENDS THEN 24" O.C. (1 1/4" EMBEDMENT) (OR, USE FASTENERS FOR HOLLOW C-90 BLOCK)

*LAGS AND BOLTS CAN BE COUNTERSUNK TO PROVIDE A FLUSH MOUNTING SURFACE.
*PREPARATION OF WOOD JAMBS BY OTHERS

EMBEDMENT

WOOD STRUCTURE CONCRETE STRUCTURE HOLLOW BLOCK STRUCTURE GROUTED BLOCK STRUCTURE

1/2" MIN 2-3/4" MIN 1-1/2" MIN 4"

2X6 JAMB TYP.

3" MIN

REV	DESCRIPTION OF REVISIONS	DATE	BY
A	UPDATED WJATS, TCDDTS, ADDED ASCE MPH DETAIL	4/26/12	RLR

MAX SIZE
18'2" x 24'

DESIGN LOADS
+19.9 PSF
-22.4 PSF

TEST LOADS
+29.9 PSF
-33.6 PSF



Amarr

165 CARRIAGE COURT WINSTON-SALEM, N.C. 27105 WWW.AMARR.COM

MODEL 2400 (24 GA)
MODEL 2000 (20 GA)

SIZE	DRAWN BY	SKW	DATE	10/15/07	DRAWING NUMBER
B	CHECKED BY	BHG	DATE	10/16/07	IBC-2418-120-24

ENGINEER: THOMAS L. SHELMERDINE P.E. LIC. No. 0048579 SHEET 3 OF 3