

TYPICAL TOP FIXTURES  
N.T.S. 1

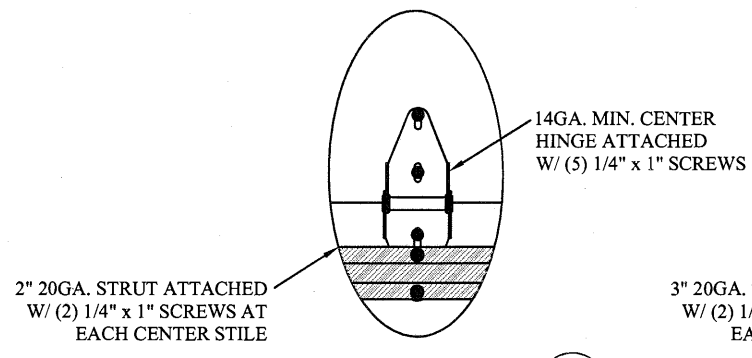

EVEN SECTION CENTER HINGE  
N.T.S. 2

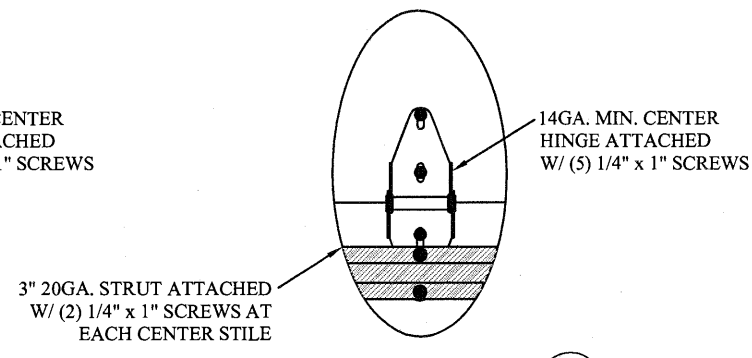

ODD SECTION CENTER HINGE  
N.T.S. 3

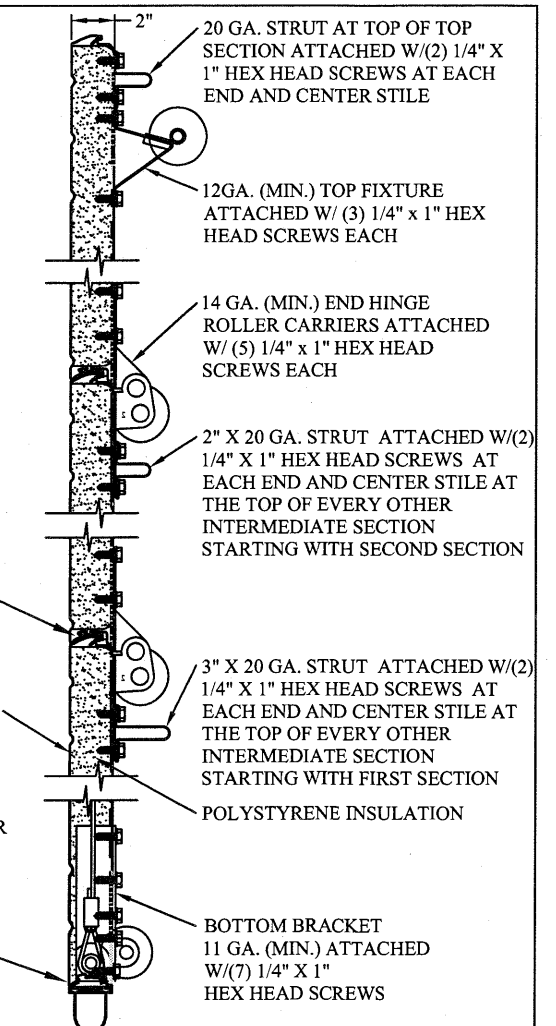

SECTION A-A (SIDE VIEW)  
N.T.S.

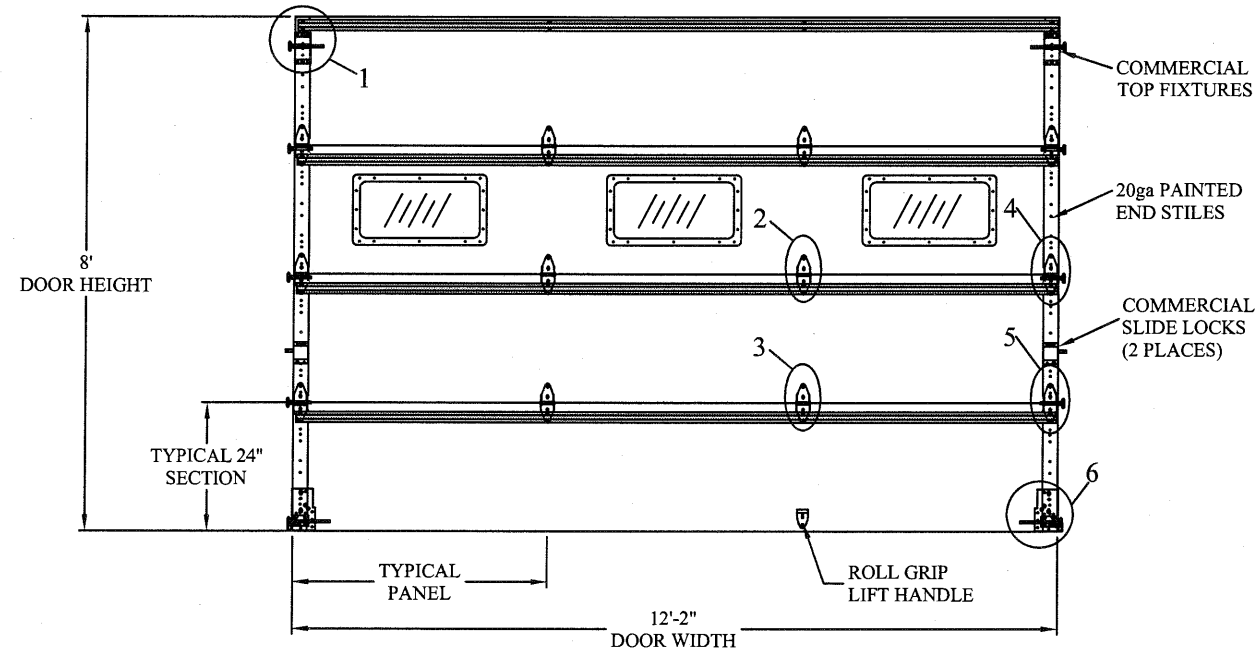

DOOR INTERIOR ELEVATION  
N.T.S.

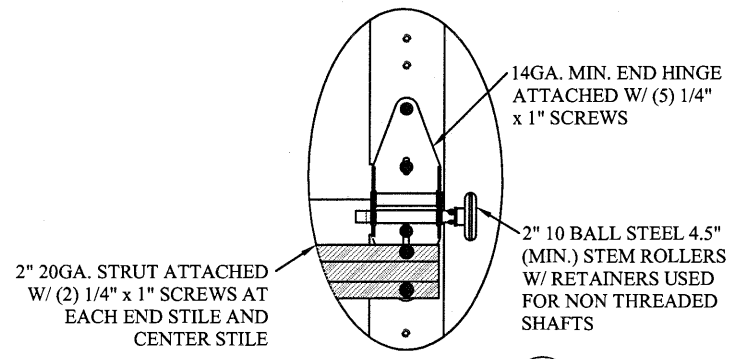

EVEN SECTION END HINGE  
N.T.S. 4

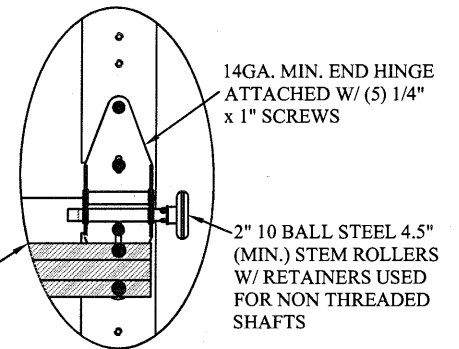

ODD SECTION END HINGE  
N.T.S. 5

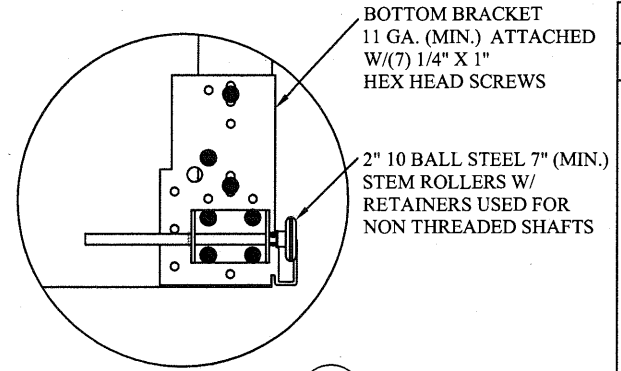

TYPICAL BOTTOM BRACKET  
N.T.S. 6

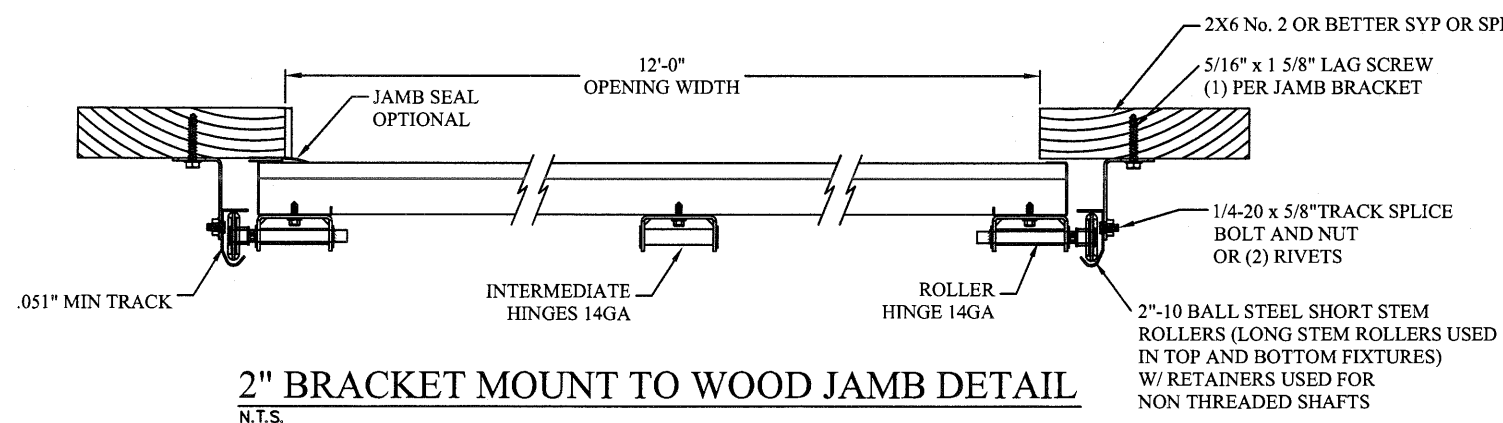

2\"/>

THE METHOD OF TESTING WAS IN SUBSTANTIAL CONFORMANCE WITH THE PROCEDURES DESCRIBED IN DASMA 108. THE PRESSURES SHOWN ON THE DRAWINGS WERE CALCULATED USING ASCE 7-98/02/05 WITH THE FOLLOWING PARAMETERS (5 FEET OF DOOR WIDTH IN END ZONE, ROOF SLOPE 10' OR LESS, AND I=1.0):

WIND SPEED (MPH)	120	109	103	99	95
EXPOSURE LEVEL	B	C	C	D	D
MEAN ROOF HEIGHT	30'	15'	25'	15'	25'

REV	DESCRIPTION OF REVISIONS	DATE	BY

MAX SIZE 12'2 x 24'  
 DESIGN LOADS +20.2 PSF -23.2 PSF  
 TEST LOADS +30.3 PSF -34.8 PSF

Thomas L. Shelmerdine, PE (TX PE #85829)  
 Structural Solutions, PA (TX Firm #004063)

STATE OF TEXAS  
 THOMAS L. SHELMERDINE  
 85829  
 LICENSED PROFESSIONAL ENGINEER

TX

5921-G W. Friendly Ave., Greensboro, NC 27410

**Amarr**  
ENTREMATICS

MODEL 1000 AMARR 2432

SIZE	DRAWN BY	DRD	DATE	2/20/18	DRAWING NUMBER
B	CHECKED BY	RLR	DATE	4/23/18	IBC-1012-120-15

ENTREMATICS  
165 CARRIAGE COURT WINSTON-SALEM, N.C. 27105

SHEET 1 OF 4

## TRACK CONNECTION DIRECTLY TO STRUCTURE OPTIONS

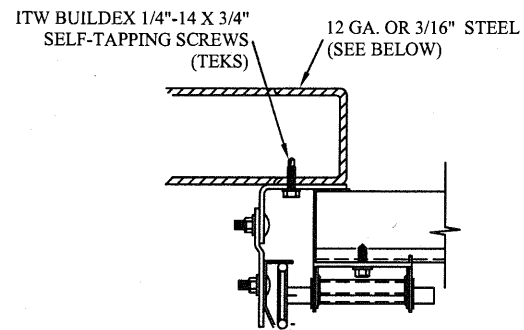

CLIP STYLE REVERSE ANGLE MOUNT SHOWN  
BRACKET, CONTINUOUS AND TAPERED ANGLE  
MOUNT AVAILABLE

12 GA. STEEL FRAMING  
232 LBS./SCREW ALLOWABLE LOAD - 6" FROM ENDS  
AND 22" O.C.  
REFER TO NOTES: 1, 2 AND 5

3/16" STEEL FRAMING  
569 LBS./SCREW ALLOWABLE LOAD - 6" FROM ENDS  
AND 24" O.C.  
REFER TO NOTES: 1, 2 AND 5

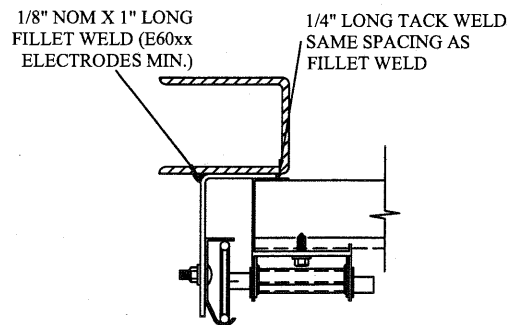

REVERSE ANGLE MOUNT SHOWN  
BRACKET, CONTINUOUS AND TAPERED  
ANGLE MOUNT AVAILABLE

STEEL FRAMING 12GA OR BETTER  
1590 LBS./IN. ALLOWABLE LOAD - 6"  
FROM ENDS AND 24" O.C.  
REFER TO NOTES: 1, 2, 5, 6, 7, 8 AND 9

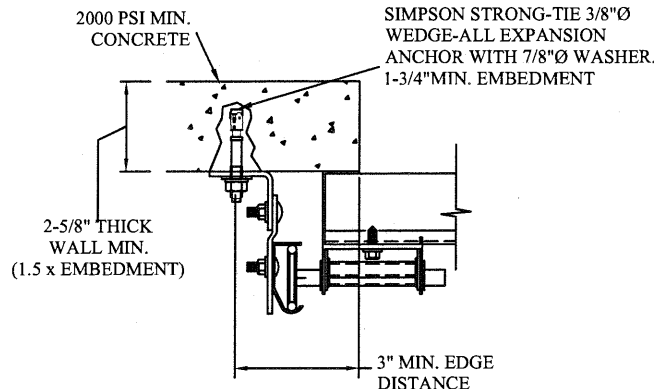

CLIP STYLE CONTINUOUS ANGLE MOUNT SHOWN  
BRACKET, REVERSE AND TAPERED ANGLE MOUNT  
AVAILABLE

2000 PSI CONCRETE OR GREATER  
351 LBS./EXPANSION ANCHOR ALLOWABLE LOAD - 6"  
FROM ENDS AND 24" O.C.  
REFER TO NOTES: 1, 2, 3, 4 AND 5

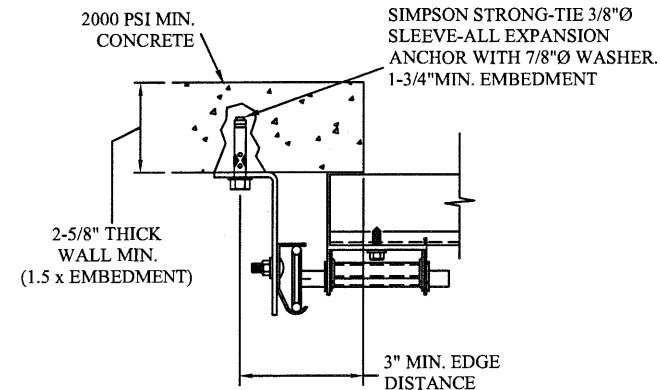

CONTINUOUS ANGLE MOUNT SHOWN  
BRACKET, CONTINUOUS AND TAPERED ANGLE  
MOUNT AVAILABLE

2000 PSI CONCRETE OR GREATER  
336 LBS./EXPANSION ANCHOR ALLOWABLE LOAD - 6"  
FROM ENDS AND 24" O.C.  
REFER TO NOTES: 1, 2, 3, 4 AND 5

### SPECIFICATIONS AND NOTES

1. ALL THE LOAD FROM THE DOOR IS TRANSFERRED TO THE VERTICAL TRACK, FROM THE TRACK THE LOAD IS TRANSFERRED TO THE VERTICAL JAMBS. THE HORIZONTAL JAMB OR HEADER RECEIVES NO PORTION OF THE LOAD TRANSFERRED FROM THE DOOR.
2. EACH VERTICAL JAMBS RECEIVES MAXIMUM DESIGN LOADS OF: +122.9 LBS/FT & -141.1 LBS/FT
3. DOOR AND HARDWARE WILL BE DESIGNED, MANUFACTURED AND INSTALLED WITH STANDARDS AS SET FORTH BY DASMA.
4. DOOR SECTIONS SHALL BE 24 GA. (.021) MIN. EXTERIOR SKIN ROLLED FORMED, W/ BAKED ON POLYESTER FINISH
5. DOORS UP TO 24'0" HIGH ALTERNATE BETWEEN (1) 3" 20GA STRUT AND (1) 2" 20GA STRUT PER SECTION STARTING WITH A 3" ON THE BOTTOM SECTION
6. SUPPORTING STRUCTURAL ELEMENTS SHALL BE DESIGNED BY A REGISTERED PROFESSIONAL ENGINEER FOR WIND LOADS INDICATED ON THIS DRAWING IN ADDITION TO OTHER LOADINGS.

## WOOD JAMB ATTACHMENT TO STRUCTURE (OPTIONAL)

- 2 X 6 VERTICAL JAMB ATTACHMENT TO WOOD FRAME STRUCTURE**  
5/16" X 3" LAG SCREWS STARTING 6" FROM ENDS THEN 24" O.C. (1 1/2" EMBEDMENT)
  - 2 X 6 VERTICAL JAMB ATTACHMENT TO 2,000 PSI CONCRETE**  
HILTI KWIK BOLT 3/8" X 4" STARTING 6" FROM ENDS THEN 24" O.C. (2 1/2" EMBEDMENT)  
HILTI SLEEVE ANCHOR 3/8" X 2-3/4" STARTING 6" FROM ENDS THEN 24" O.C. (1 1/4" EMBEDMENT)  
ITW/RAMSET REDHEAD (TRU-BOLT) 3/8" X 4" STARTING 6" FROM ENDS THEN 24" O.C. (2 1/2" EMBEDMENT)
  - 2 X 6 VERTICAL JAMB ATTACHMENT TO HOLLOW C-90 BLOCK**  
SIMPSON 1/4" X 3" TITEN SCREWS STARTING 6" FROM ENDS, USE PAIRS OF FASTENERS (3" APART) AT 24" O.C. (1 1/2" EMBEDMENT)  
HILTI 1/4" X 2-3/4" KWIK-CON II+ SCREWS STARTING 6" FROM ENDS, USE PAIRS OF FASTENERS (3" APART) AT 24" O.C. (1 1/4" EMBEDMENT)
  - 2 X 6 VERTICAL JAMB ATTACHMENT TO GROUTED C-90 BLOCK (2000 PSI GROUT)**  
HILTI SLEEVE ANCHOR 3/8" X 2-3/4" STARTING 6" FROM ENDS THEN 24" O.C. (1 1/4" EMBEDMENT)  
(OR, USE FASTENERS FOR HOLLOW C-90 BLOCK)
- \*LAGS AND BOLTS CAN BE COUNTERSUNK TO PROVIDE A FLUSH MOUNTING SURFACE.  
\*PREPARATION OF WOOD JAMBS BY OTHERS

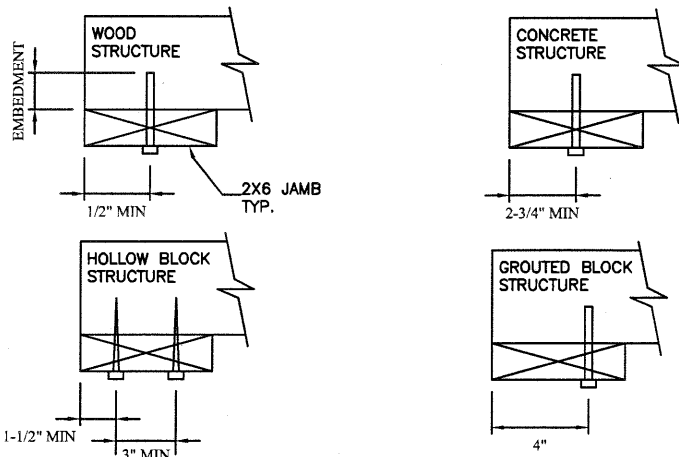

- NOTES:**
1. ANCHORS TO BE EVENLY SPACED BETWEEN THE HEADER AND FLOOR.
  2. FIRST (BOTTOM) ANCHOR STARTING AT NO MORE THAN HALF OF THE MAXIMUM ON-CENTER DISTANCE. HIGHEST ANCHOR INSTALLED AT LEAST AS HIGH AS THE DOOR OPENING.
  3. MIN. EDGE DISTANCE OF 3" REQUIRED.
  4. USE WASHERS PROVIDED BY THE ANCHOR MANUFACTURER.
  5. SUPPORTING STRUCTURAL ELEMENTS SHALL BE DESIGNED BY A REGISTERED PROFESSIONAL ENGINEER FOR WIND LOADS IN ADDITION TO OTHER LOADS.
  6. MOST GARAGE DOOR TRACK IS GALVANIZED STEEL. USE ALL NECESSARY PRECAUTIONS WHEN WELDING GALVANIZED STEEL.
  7. ALL WELDS SHOULD BE PERFORMED BY A CERTIFIED WELDER OR INSPECTED BY A CERTIFIED WELDING INSPECTOR TO VERIFY THE INTEGRITY OF THE WELD.
  8. FILLET WELDS TO HAVE A STRAIGHT OR CONVEX FACE SURFACE.
  9. TACK WELD TOE OF ANGLE AT SAME SPACING TO PREVENT ROTATION OF TRACK ANGLE.

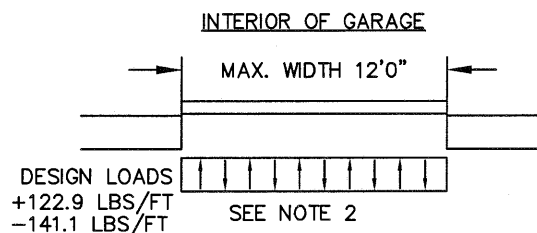

## TRACK CONNECTION TO WOOD JAMB OPTIONS

FOR LAG SCREWS & BRACKET SPACING SEE PAGE 4 FOR TRACK CONFIGURATION DETAIL

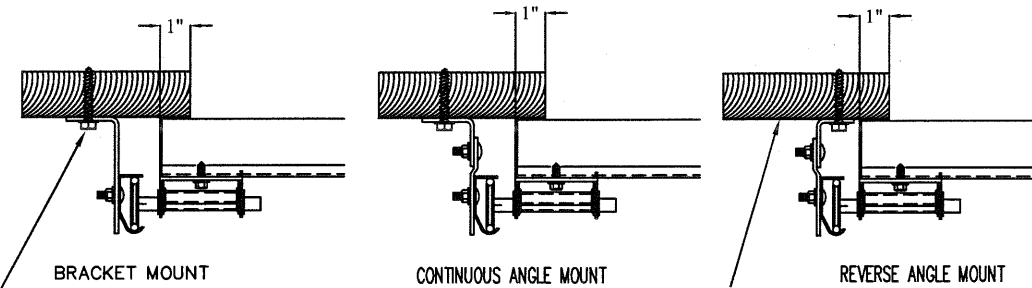

5/16" x 1 5/8" LAG SCREW (1) PER JAMB BRACKET (1-1/2" EMBEDMENT MINIMUM) (TYP.)

2x6 WOOD JAMB SYP OR SPF (NO.2) OR BETTER (TYP.)

REV	DESCRIPTION OF REVISIONS	DATE	BY

MAX SIZE  
12'2 x 24'

DESIGN LOADS  
+20.2 PSF  
-23.2 PSF

TEST LOADS  
+30.3 PSF  
-34.8 PSF

TX

Amarr

ENTREMATIc

MODEL 1000 AMARR 2432

Thomas L. Shelmerdine, PE (TX PE #85829)  
Structural Solutions, PA (TX Firm #F-004063)

5921-G W. Friendly Ave., Greensboro, NC 27410

SIZE	DRAWN BY	DRD	DATE	2/20/18	DRAWING NUMBER
B	CHECKED BY	RLR	DATE	4/23/18	IBC-1012-120-15

ENTREMATIc  
165 CARRIAGE COURT WINSTON-SALEM, N.C. 27105

SHEET 2 OF 4

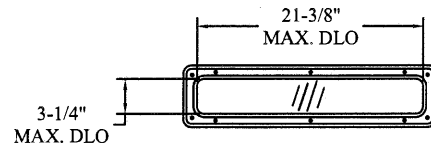
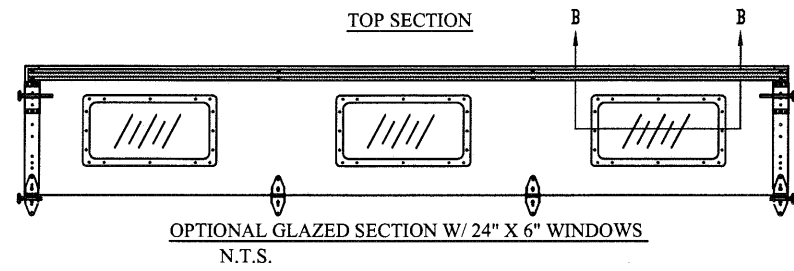

24" X 6" DAY LIGHT OPENING AND FASTENER DETAIL  
N.T.S.

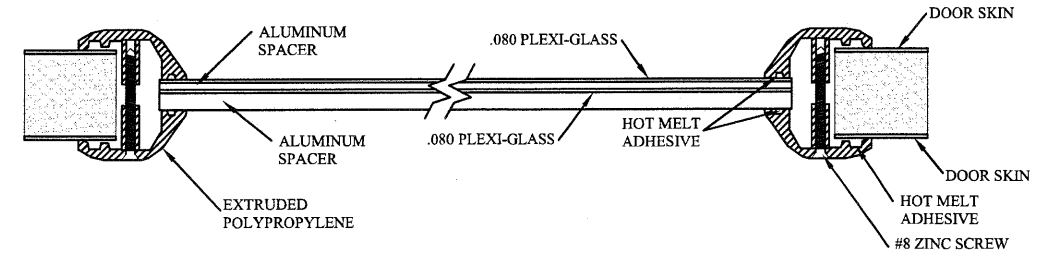
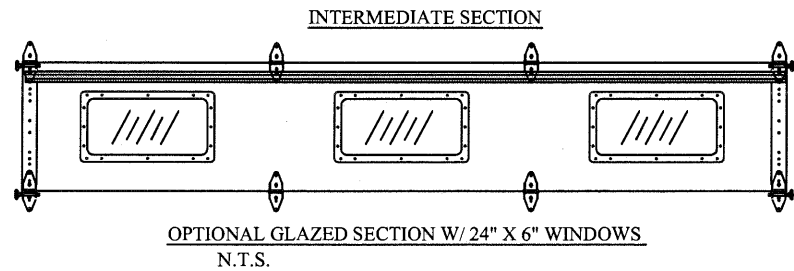

SECTION B-B 24" X 6" WINDOW DETAIL W/ .080 PLEXI-GLASS  
N.T.S.

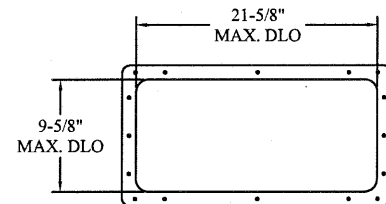

24" X 12" DAY LIGHT OPENING AND FASTENER DETAIL  
N.T.S.

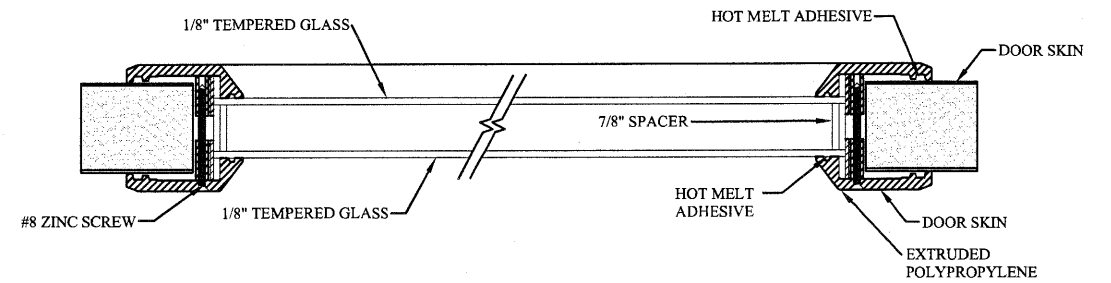

SECTION C-C 24" X 12" WINDOW DETAIL W/ 1-1/8" INSULATED GLASS  
N.T.S.

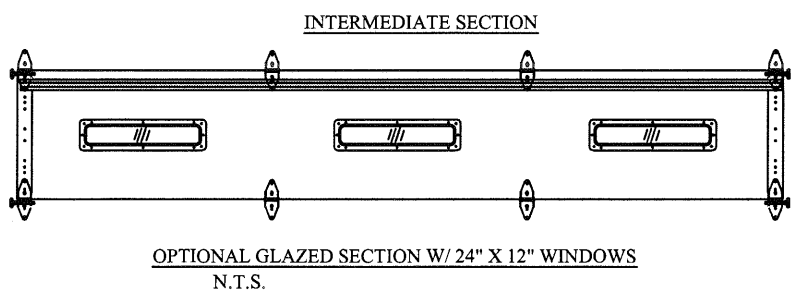
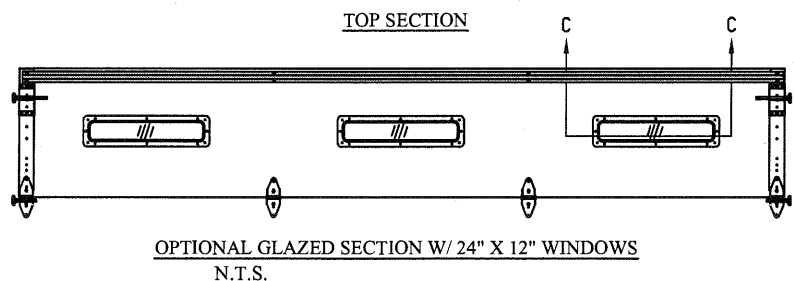

REV	DESCRIPTION OF REVISIONS	DATE	BY

MAX SIZE  
12'2 x 24'

DESIGN LOADS  
+20.2 PSF  
-23.2 PSF

TEST LOADS  
+30.3 PSF  
-34.8 PSF

Thomas L. Shelmerdine, PE (TX PE #85829)  
Structural Solutions, PA (TX Firm #F-004063)

TX

5921-G W. Friendly Ave., Greensboro, NC 27410

**Amarr**  
ENTREMATIc

MODEL 1000 AMARR 2432

SIZE	DRAWN BY	DRD	DATE	2/20/18	DRAWING NUMBER IBC-1012-120-15
B	CHECKED BY	RLR	DATE	4/23/18	

ENTREMATIc  
165 CARRIAGE COURT WINSTON-SALEM, N.C. 27105

SHEET 3 OF 4

TABLE 1

Section Width (ft)	Center Stile Locations		Max Design Loads Allowed	
	1st (in)	2nd (in)	Positive (PSF)	Negative (PSF)
6' 0"	36"	-	27.2	31.2
6' 2"	37"	-	26.4	30.4
6' 4"	38"	-	25.7	29.6
6' 6"	39"	-	25.1	28.8
6' 8"	40"	-	24.4	28.1
6' 10"	41"	-	23.8	27.4
7' 0"	42"	-	23.3	26.7
7' 2"	43"	-	22.7	26.1
7' 4"	44"	-	22.2	25.5
7' 6"	45"	-	21.7	25.0
7' 8"	46"	-	21.2	24.4
7' 10"	47"	-	20.8	23.9
8' 0"	48"	-	20.4	23.4
9' 4"	36"	76"	25.6	29.4
9' 6"	37"	77"	25.3	29.0
9' 8"	38"	78"	24.9	28.7
9' 10"	39"	79"	24.6	28.3
10' 0"	40"	80"	24.3	27.9
10' 2"	41"	81"	24.0	27.6
10' 4"	42"	82"	23.6	27.1
10' 6"	43"	83"	23.2	26.7
10' 8"	44"	84"	22.9	26.3
10' 10"	45"	85"	22.5	25.9
11' 0"	46"	86"	22.2	25.5
11' 2"	47"	87"	21.8	25.1
11' 4"	48"	88"	21.5	24.7
11' 6"	49"	89"	21.2	24.4
11' 8"	50"	90"	20.9	24.0
11' 10"	51"	91"	20.6	23.7
12' 0"	48"	96"	20.3	23.3
12' 2"	49"	97"	20.2	23.2

\* CONTACT ENGINEERING FOR SIZES 82" THROUGH 92"

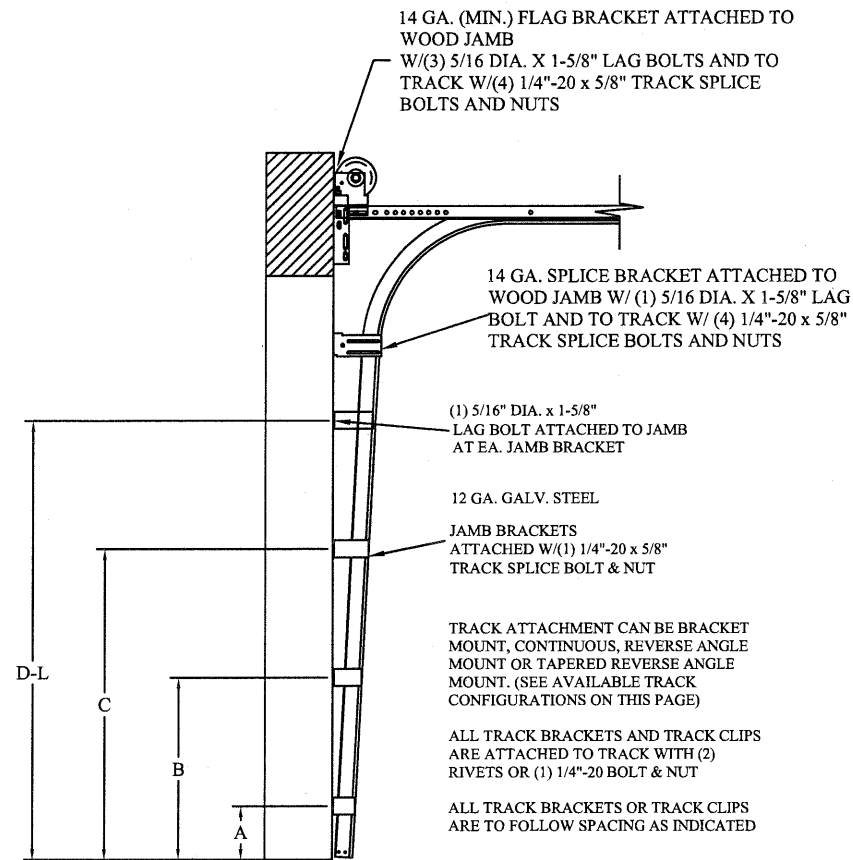

TRACK CONFIGURATION FOR UP TO 24' TALL DOORS  
SEE TABLE 2

TABLE 2

DOOR HEIGHT	TRACK ATTACHMENT											TYPICAL SPLICE
	A	B	C	D	E	F	G	H	I	J	K	
7' 0"	10.0"	34"	58"									76"
7' 6"	10.0"	34"	58"									82"
8' 0"	10.0"	34"	58"									88"
8' 6"	10.0"	34"	58"	82"								94"
9' 0"	10.0"	34"	58"	82"								100"
9' 6"	10.0"	34"	58"	82"								106"
10' 0"	10.0"	34"	58"	82"								112"
11' 0"	10.0"	34"	58"	82"	106"							124"
12' 0"	10.0"	34"	58"	82"	106"							136"
13' 0"	10.0"	34"	58"	82"	106"	130"						148"
14' 0"	10.0"	34"	58"	82"	106"	130"						160"
15' 0"	10.0"	34"	58"	82"	106"	130"	154"					172"
16' 0"	10.0"	34"	58"	82"	106"	130"	154"					184"
17' 0"	10.0"	34"	58"	82"	106"	130"	154"	178"				196"
18' 0"	10.0"	34"	58"	82"	106"	130"	154"	178"				208"
19' 0"	10.0"	34"	58"	82"	106"	130"	154"	178"	202"			220"
20' 0"	10.0"	34"	58"	82"	106"	130"	154"	178"	202"			232"
21' 0"	10.0"	34"	58"	82"	106"	130"	154"	178"	202"	226"		244"
22' 0"	10.0"	34"	58"	82"	106"	130"	154"	178"	202"	226"		256"
23' 0"	10.0"	34"	58"	82"	106"	130"	154"	178"	202"	226"	250"	268"
24' 0"	10.0"	34"	58"	82"	106"	130"	154"	178"	202"	226"	250"	280"

ALL TRACK ATTACHMENTS +/- 2" ALLOWED USING SYP OR SPF NO.2 OR BETTER ONLY

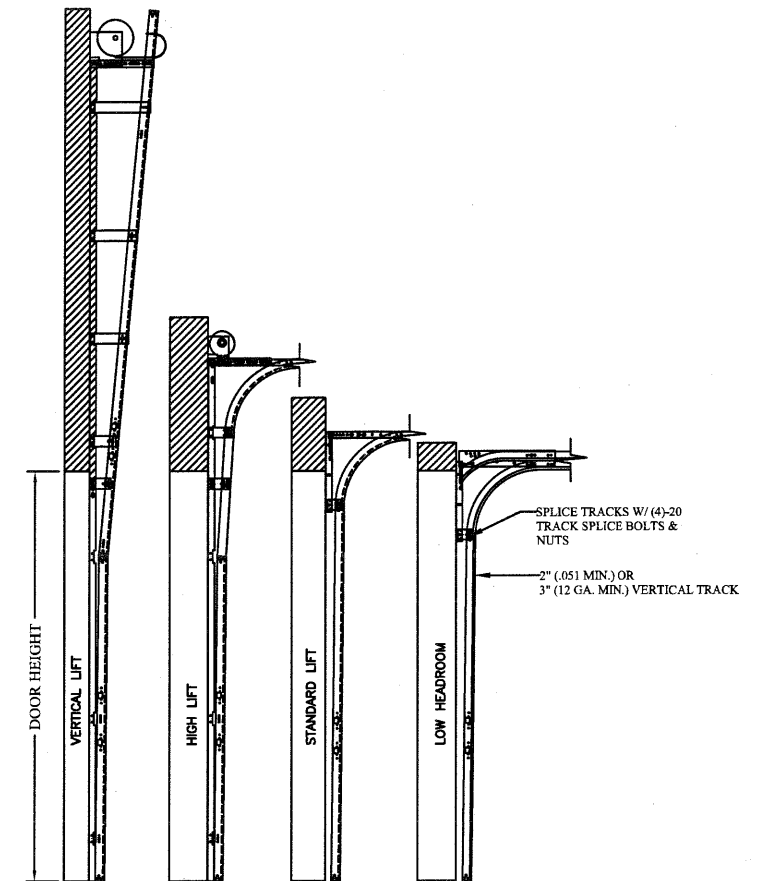

AVAILABLE TRACK CONFIGURATIONS  
N.T.S.

REV	DESCRIPTION OF REVISIONS	DATE	BY

MAX SIZE 12'2 x 24'

DESIGN LOADS +20.2 PSF -23.2 PSF

TEST LOADS +30.3 PSF -34.8 PSF

Thomas L. Shelmerdine, PE (TX PE #85829) Structural Solutions, PA (TX Firm #F-004063)

STATE OF TEXAS  
THOMAS L. SHELME RDINE  
85829  
LICENSED PROFESSIONAL ENGINEER  
TX

Amarr  
ENTREMATIC

MODEL 1000 AMARR 2432

SIZE	DRAWN BY DRD	DATE 2/20/18	DRAWING NUMBER
B	CHECKED BY RLR	DATE 4/23/18	IBC-1012-120-15

ENTREMATIC  
165 CARRIAGE COURT WINSTON-SALEM, N.C. 27105

5921-G W. Friendly Ave., Greensboro, NC 27410

SHEET 4 OF 4