

GENERAL NOTES AND SPECIFICATIONS:

1. SERIES LS20GA FLUSH COMMERCIAL STEEL INSWING DOOR SHOWN ON THIS PRODUCT EVALUATION DOCUMENT (P.E.D.) HAS BEEN VERIFIED FOR CODE COMPLIANCE IN ACCORDANCE WITH THE **2018** EDITION OF THE INTERNATIONAL BUILDING CODE, **(IBC)**.

DESIGN WIND LOADS SHALL BE DETERMINED AS PER SECTION **1609** OF THE INTERNATIONAL BUILDING CODE, FOR A BASIC WIND SPEED AS REQUIRED BY THE JURISDICTION WHERE PRODUCT WILL BE INSTALLED, AND FOR A DIRECTIONALITY FACTOR $K_d = 0.85$, IN ACCORDANCE WITH ASCE **7-16** STANDARD, AND SHALL NOT EXCEED THE DESIGN PRESSURE RATING INDICATED ON SHEET 2.

IN ORDER TO VERIFY THAT ANCHORS ON THIS P.E.D., AS TESTED, WERE NOT OVERSTRESSED, A 33% INCREASE IN ALLOWABLE STRESS FOR WIND LOADS WAS NOT USED IN THEIR ANALYSIS. FASTENERS SPACING TO WOOD HAS BEEN DETERMINED IN ACCORDANCE WITH N.D.S. **2018**.

THIS DOOR'S ADEQUACY FOR IMPACT AND CYCLIC RESISTANCE HAS BEEN VERIFIED IN ACCORDANCE WITH SECTION **1609.2** OF THE ABOVE MENTIONED CODE AS PER FLORIDA HIGH VELOCITY HURRICANE ZONE PROTOCOLS TAS-201, TAS-202, TAS-203 AS PER FENESTRATION TESTING LABORATORY, INC. REPORT # 8974, AND AS PER SUBMITTED STRUCTURAL CALCULATIONS, PERFORMED AS PER SECTION **1604** OF THE ABOVE MENTIONED BUILDING CODE.

2. ALL COMPONENTS SHALL BE AS SPECIFIED ON APPLICABLE DETAIL SHEETS AND AT BILL OF MATERIALS (SHEET 5) OF THIS DRAWING.

3. COMPLIANCE OF EGRESS / ESCAPE REQUIREMENTS OF THESE DOORS PER ABOVE MENTIONED BUILDING CODE TO BE DETERMINED BY BUILDING OFFICIALS ON A CASE-BY-CASE BASIS.

4. ALL SCREWS TO BE STAINLESS STEEL 304 OR 316 AISI SERIES AND MEET ASTM A167, OR HOT DIPPED GALVANIZED (AFTER FABRICATION) CARBON STEEL AS PER ASTM A123 OR ASTM A153, OR HOT DIPPED GALVANIZED OR GALVANNEALED (PRIOR TO FABRICATION) AND MEET ASTM A653 WITH 50 ksi YIELD STRENGTH AND 90 hsi TENSILE STRENGTH. BOLTS TO BE ASTM A-307 GALVANIZED STEEL OR AISI 304 SERIES STAINLESS STEEL, WITH 35 KSI MINIMUM YIELD STRENGTH.

5. ALL WELDING TO CONFORM W/AMERICAN WELDING SOCIETY A.W.S. D.1.3 AND D-19.0 REGULATIONS WITH E60XX ELECTRODES, FOR GALVANNEAL MATERIAL, AND W/AMERICAN WELDING SOCIETY A.W.S. D.1.6 REGULATIONS W/ E-308 ELECTRODES (FU=80k.s.i.) FOR STAINLESS STEEL MATERIAL

6. ALL ANCHORS FOR DOOR FRAME CONNECTIONS TO EXISTING STRUCTURE SHALL BE AS SPECIFIED ON SHEET 13 OF THIS DRAWING. MAXIMUM ANCHORS SPACINGS SHALL BE AS PER ELEVATIONS ON SHEET 3 OF THIS DRAWING.

7. PROVIDE MAX. LOAD BEARING SHIM SPACE AS INDICATED ON SHEET 12.

8. THIS DOOR WILL NOT REQUIRE A HURRICANE PROTECTION DEVICE. DOOR MEETS IMPACT RESISTANCE FOR TYPE "D" MISSILE FOR BASIC PROTECTION.

9. THESE DOOR ASSEMBLIES ARE APPROVED FOR WATER AND AIR INFILTRATION AS PER TESTING INDICATED ON GENERAL NOTE 1, AND SHALL BE LIMITED TO DESIGN PRESSURE RATINGS INDICATED ON SHEET 2.

10. PROVIDE SPECIFIED SEALANT AT ALL DOOR FRAME & THRESHOLD COMPONENTS INDICATED ON THIS DRAWING.

11. ALL EXISTING WALLS (STRUCTURE) WHERE DOOR IS TO BE INSTALLED MUST BE BUILT IN ACCORDANCE WITH THE INTERNATIONAL BUILDING CODE AND SHALL BE DESIGNED TO SUSTAIN THE SUPERIMPOSED LOADS TRANSFERRED BY THE DOOR SYSTEM.

12. ALL ALUMINUM EXTRUSIONS IN CONTACT WITH DISSIMILAR MATERIALS SHALL COMPLY WITH SECTION III-6 OF THE ALUMINUM DESIGN MANUAL 2015 EDITION.

13. PERMIT HOLDER SHALL VERIFY THE ADEQUACY OF THE EXISTING STRUCTURE TO SUSTAIN THE SUPERIMPOSED LOADS TRANSFERRED BY THESE DOORS.

14. (a) THIS P.E.D. PREPARED BY THIS ENGINEER IS GENERIC AND DOES NOT PROVIDE INFORMATION FOR A SITE SPECIFIC PROJECT; i.e. WHERE THE SITE CONDITIONS DEVIATE FROM THE P.E.D.

(b) CONTRACTOR TO BE RESPONSIBLE FOR THE SELECTION, PURCHASE AND INSTALLATION INCLUDING LIFE SAFETY OF THIS PRODUCT, BASED ON THIS P.E.D., PROVIDED HE/SHE DOES NOT DEVIATE FROM THE CONDITIONS DETAILED ON THIS DOCUMENT. CONSTRUCTION SAFETY AT SITE IS THE CONTRACTOR'S RESPONSIBILITY.

(c) THIS P.E.D. WILL BE CONSIDERED INVALID IF ALTERED BY ANY MEANS.

(d) SITE SPECIFIC PROJECTS SHALL BE PREPARED BY A PROFESSIONAL ENGINEER OR ARCHITECT WHICH WILL BECOME THE ENGINEER OF RECORD (E.O.R.) FOR THE PROJECT AND WHO WILL BE RESPONSIBLE FOR THE PROPER USE OF THE P.E.D.

(e) ORIGINAL P.E.D. SHALL BEAR THE DATE AND ORIGINAL SEAL AND SIGNATURE OF THE PROFESSIONAL ENGINEER OF RECORD THAT PREPARED IT.

15. PRODUCT MANUFACTURER'S LABEL SHALL BE LOCATED ON A READILY VISIBLE LOCATION AT PRODUCT IN ACCORDANCE WITH TEXAS DEPARTMENT OF INSURANCE REQUIREMENTS. ONE LABEL SHALL BE PLACED FOR EVERY OPENING.

16. EXPANDED POLYSTYRENE CORE SHALL BE RIGID BOARD TYPE 1 PCF CONFORMING TO ASTM C578 BY DYPLAST PRODUCTS LLC, W/ CURRENT MIAMI DADE COUNTY PRODUCT CONTROL EVALUATION (NOA).

SHEETS CONTENT:

SHEET #1	INDEX, COVER SHEET & GENERAL NOTES.
SHEET #2	ASSEMBLY ELEVATIONS.
SHEET #3	ANCHOR ELEVATIONS.
SHEET #4	OPTIONAL EMBOSSED DOOR SLAB.
SHEET #5	BILL OF MATERIALS.
SHEETS #6-#8	COMPONENTS.
SHEET #9	VERTICAL SECTIONS.
SHEETS #10-11	HORIZONTAL SECTIONS AT HARDWARE.
SHEET #12	ANCHOR SECTIONS.
SHEET #13	DOOR SURFACE CLOSER REINFORCEMENT AND END CHANNEL ASSEMBLY DETAIL + CORNER DETAILS.

THIS DRAWING SHALL ONLY BE USED TO OBTAIN PERMITS UNDER THE TEXAS DEPARTMENT OF INSURANCE JURISDICTION



10/1/2021
P.E. SEAL/SIGNATURE/DATE

WALTER A. TILLIT Jr P.E.
PROFESSIONAL ENGINEER
6355 N.W 36 STREET, STE. 305
VIRGINIA GARDENS, FL 33166
PHONE(305) 871-1530 FAX (305) 871-1531
TEXAS LIC. # 90691
FIRM REGISTRATION # F-13790

TEXAS DEPARTMENT OF INSURANCE - 2018					
SERIES LS20GA FLUSH COMMERCIAL STEEL INSWING DOOR W/SERIES "AS" 18GA STEEL FRAME				DRAWN BY: M.P.	
DAYBAR INDUSTRIES LTD				9/29/2021 DATE	
50 WEST DRIVE, BRAMPTON, ON CANADA, L6T 2J4 TEL: 905 625-8000 FAX: 905 625-4204				21-122 DRAWING No	
REV. No	DESCRIPTION	DATE	REV. No	DESCRIPTION	DATE
1	OLD 17-053	9/29/21	3		
2			4		

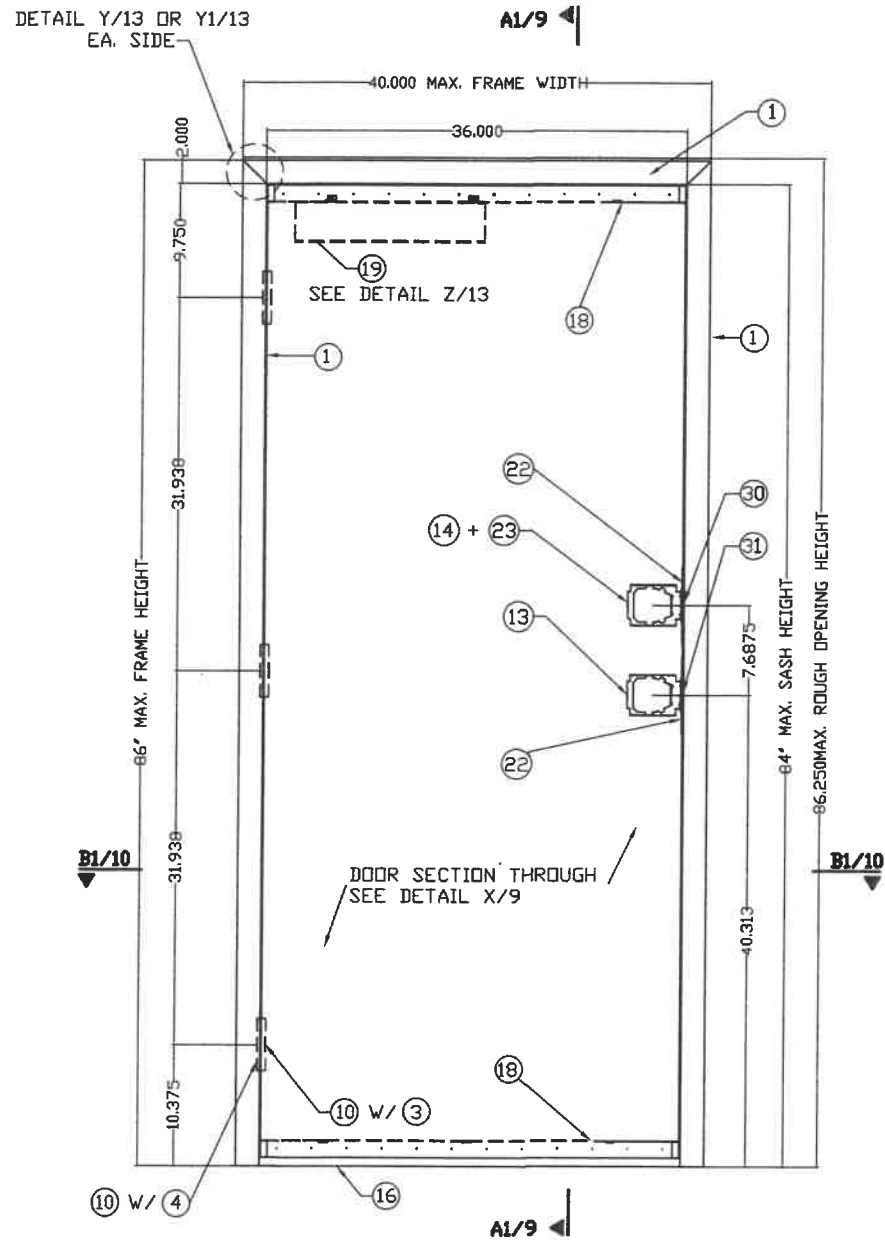

EXTERIOR ELEVATION (INSWING) DOOR
CYLINDRICAL LOCK + DEAD BOLT

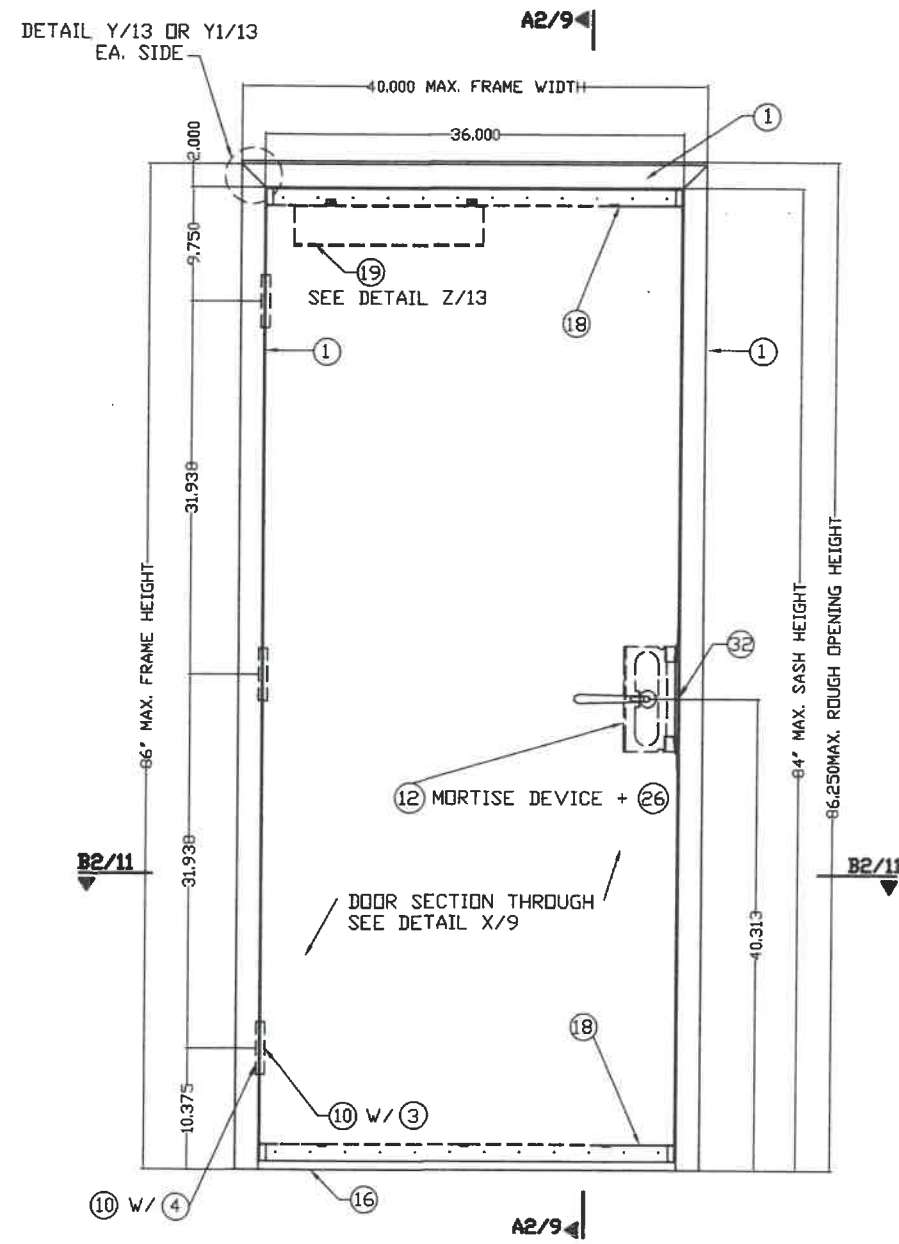

EXTERIOR ELEVATION (INSWING) DOOR
MORTISE DEVICE

DESIGN LOAD
+65.0 psf, -65.0 psf

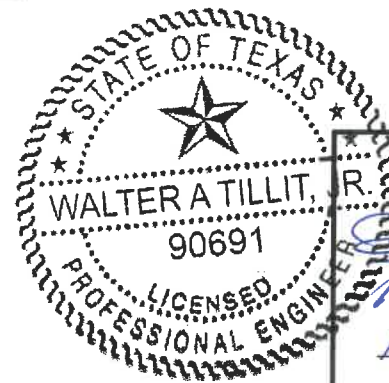

Walter A. Tillit, Jr.
P.E. SEAL/SIGNATURE/DATE

WALTER A. TILLIT Jr P.E.
PROFESSIONAL ENGINEER
6355 N.W 36 STREET, STE. 305
VIRGINIA GARDENS, FL 33166
PHONE(305) 871-1530 FAX (305) 871-1531
TEXAS LIC. # 90691
FIRM REGISTRATION # F-13790

TEXAS DEPARTMENT OF INSURANCE - 2018					
SERIES LS20GA FLUSH COMMERCIAL STEEL INSWING DOOR W/SERIES "AS" 18GA STEEL FRAME				DRAWN BY: M.P.	
DAYBAR INDUSTRIES LTD 50 WEST DRIVE, BRAMPTON, ON CANADA, L6T 2J4 TEL: 905 625-8000 FAX: 905 625-4204				9/29/2021 DATE	
21-122 DRAWING No					
REV. No	DESCRIPTION	DATE	REV. No	DESCRIPTION	DATE
1	OLD 17-053	9/29/21	3		
2			4		

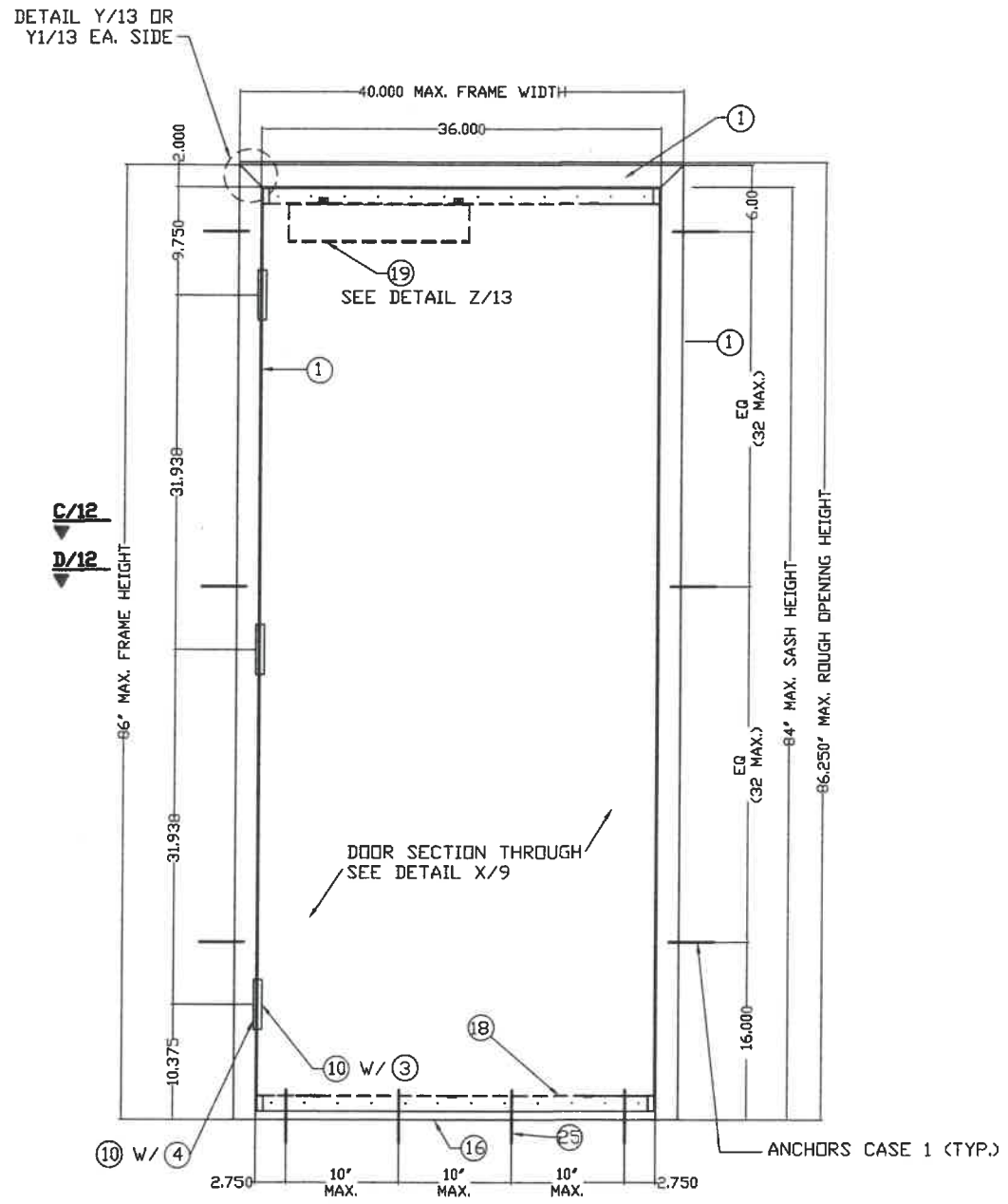

**EXTERIOR ELEVATION (INSWING) DOOR
CASE 1 (SEE SHEET 12)**

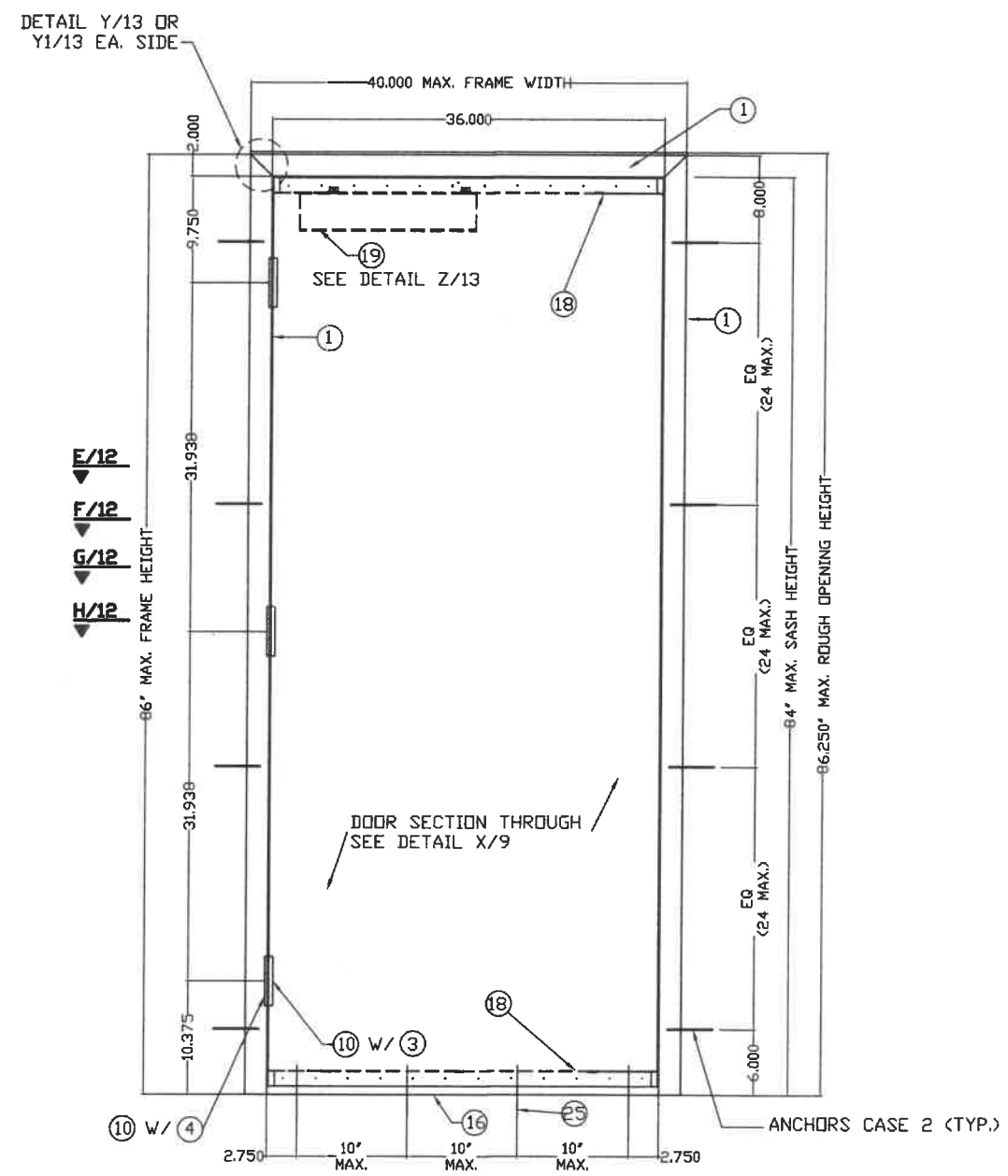

**EXTERIOR ELEVATION (INSWING) DOOR
CASE 2 (SEE SHEET 12)**

**ANCHORAGE INSTALLATION
DETAILS AT JAMBS**

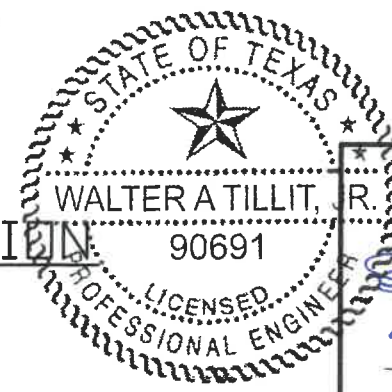

Walter A. Tillit, Jr.
10/1/2021
P.E. SEAL/SIGNATURE/DATE

WALTER A. TILLIT Jr P.E.
PROFESSIONAL ENGINEER
6355 N.W 36 STREET, STE. 305
VIRGINIA GARDENS, FL 33166
PHONE(305) 871-1530 FAX (305) 871-1531
TEXAS LIC. # 90691
FIRM REGISTRATION # F-13790

TEXAS DEPARTMENT OF INSURANCE - 2018					
SERIES LS20GA FLUSH COMMERCIAL STEEL INSWING DOOR W/SERIES "AS" 18GA STEEL FRAME				DRAWN BY: M.P.	
DAYBAR INDUSTRIES LTD				9/29/2021 DATE	
50 WEST DRIVE, BRAMPTON, ON CANADA, L6T 2J4 TEL: 905 625-8000 FAX: 905 625-4204				21-122 DRAWING No	
REV. No	DESCRIPTION	DATE	REV. No	DESCRIPTION	DATE
1	OLD 17-053	9/29/21	3		
2			4		

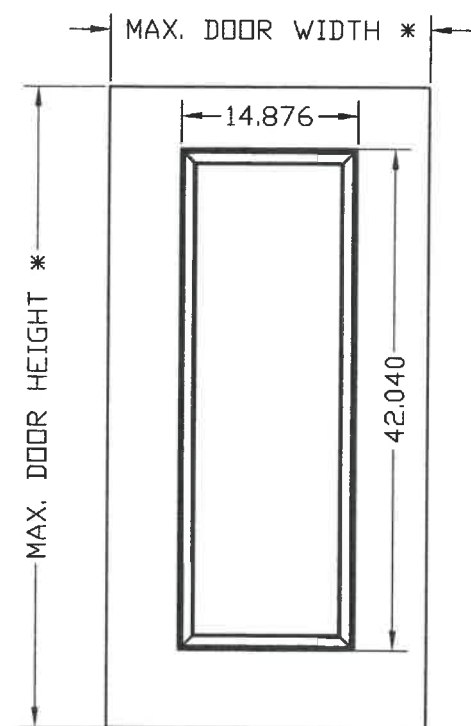
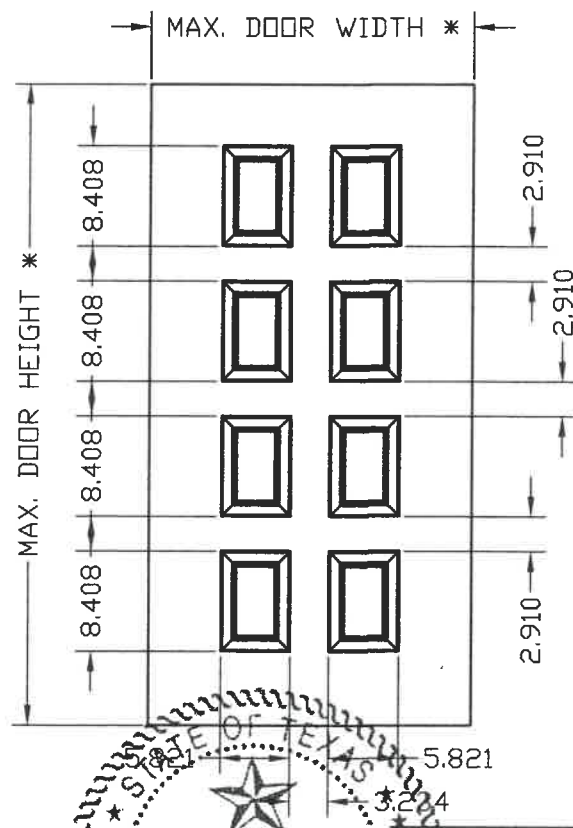
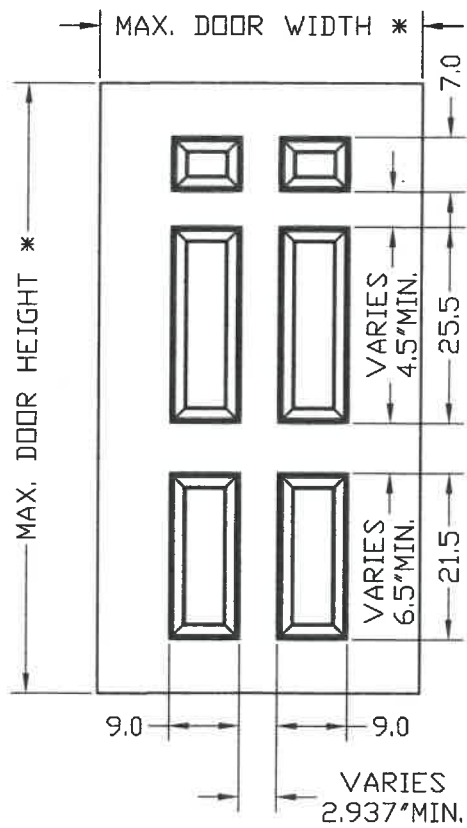
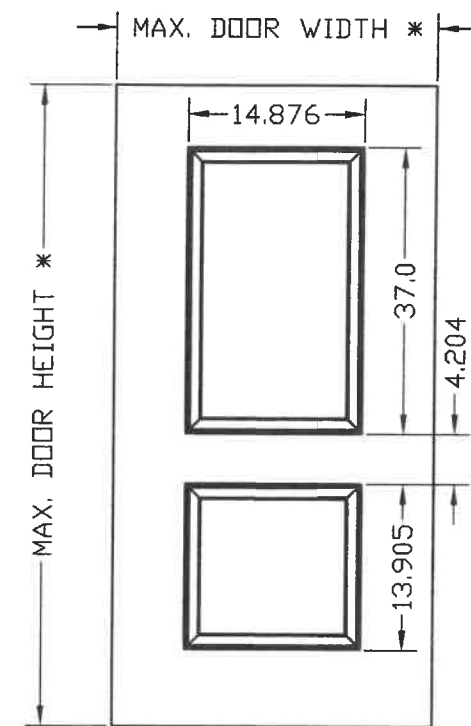
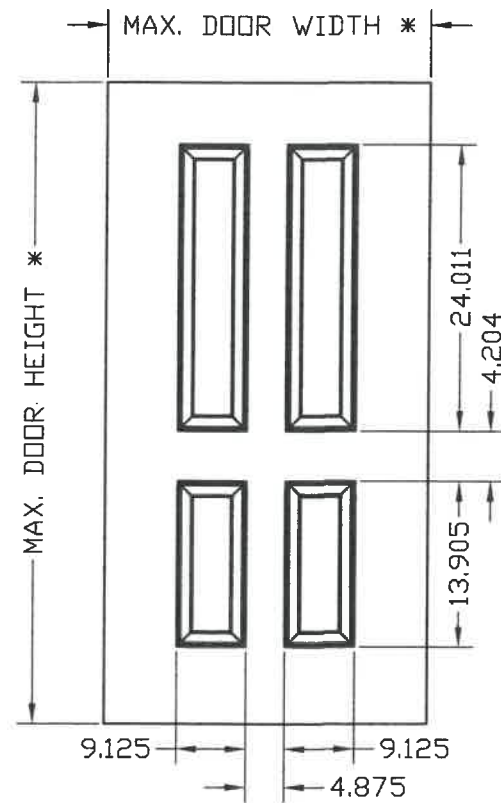
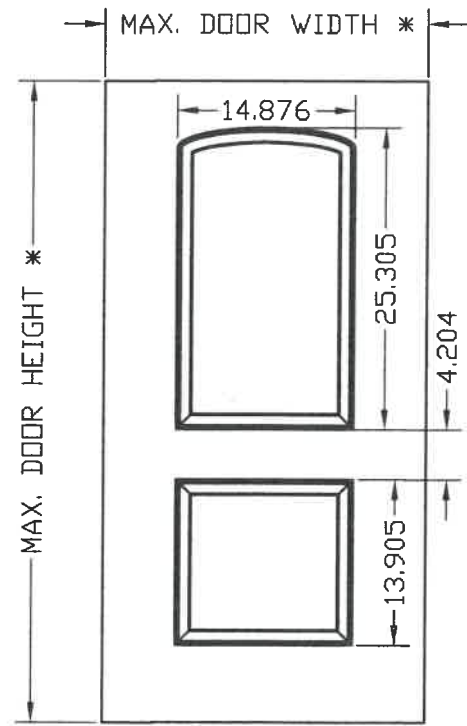

* SEE SHEET 2

OPTIONAL EMBOSSED DOOR ELEMENTS



Walter A. Tillit, Jr.
10/1/2021
P.E. SEAL/SIGNATURE/DATE

WALTER A. TILLIT Jr P.E.
PROFESSIONAL ENGINEER
6355 N.W 36 STREET, STE. 305
VIRGINIA GARDENS, FL 33166
PHONE(305) 871-1530 FAX (305) 871-1531
TEXAS LIC. # 90691
FIRM REGISTRATION # F-13790

TEXAS DEPARTMENT OF INSURANCE - 2018					
SERIES LS20GA FLUSH COMMERCIAL STEEL INSWING DOOR W/SERIES "AS" 18GA STEEL FRAME				DRAWN BY: M.P.	
DAYBAR INDUSTRIES LTD 50 WEST DRIVE, BRAMPTON, ON CANADA, L6T 2J4 TEL: 905 625-8000 FAX: 905 625-4204				9/29/2021 DATE	
				21-122 DRAWING No	
REV. No	DESCRIPTION	DATE	REV. No	DESCRIPTION	DATE
1	OLD 17-053	9/29/21	3		
2			4		

BILL OF MATERIALS INSWING DOOR:

ITEM	DESCRIPTION	BASIC DIMENSIONS, MATERIAL OR ADDITIONAL DETAILS
①, ①A	18 GAUGE WELDED FRAME	AS 5 3/4" JAMB DEPTH X 2" FACE X .042" MIN GALVANNEAL FOR ① (Fu=52Ksi, Fy=45Ksi) OR STAINLESS STEEL (Fu=94.9 Ksi, Fy=54.5 Ksi) FOR ①A, OF SAME DIMENSION
②	20 GAUGE FLUSH DOOR COMMERCIAL STEEL	1 3/4" THICK X (.032 MIN) GALVANNEAL, Fu=60Ksi Fy=45Ksi; C/W PAPER HONEY COMB OR NOA APPROVED STYRENE CORE
③	HINGE REINFORCINGS (DOOR)	1 1/4" X 10" X 10 GAUGE GALVANNEAL (.134 MIN)
④	HINGE REINFORCINGS (FRAME)	1 1/2" X 8 3/4" X 10 GAUGE GALVANNEAL (.134 MIN)
⑤	STRIKE REINFORCINGS (FRAME)	1 3/8" X 7 5/16" X 14 GAUGE GALVANNEAL (.072 MIN)
⑥	WIRE MASONRY FRAME ANCHOR	9 1/2" LONG X 10 GAUGE (.134 MIN) Fu=95.9 Ksi Fy=40.2 Ksi
⑦	2 PIECE SNAP-IN ANCHOR	1 13/16" X 4 1/8" X 20 GAUGE GALVANNEAL (.032 MIN), SNAPPED TO ACHIEVE 5 5/8" TOTAL DEPTH
⑧	EMA ANCHOR BOLTS	3/8" X 5" STEEL UNICAN-SLEEVE ANCHOR, 2 1/4" EMBEDMENT & 3" MIN. E.D.
⑧A	EMA BUTTERFLY ANCHOR (PART #PT1-008)	18 GAUGE (.042") STEEL SATIN COAT
⑨	LAG SCREW	3/8"Ø x 6" LAG SCREW
⑩	HINGES-HAGER BB1191, BB1279, BB1168HD OR STANLEY FBB179, FBB168	MIN. 4" TO 4.5" X 4.5" STANDARD WEIGHT (.134 THICK), STEEL, ATTACHED TO FRAME W/ (4) 12-24 x 1/2" FHMS
⑫	MORTISE DEVICE: SCHLAGE L9000 SERIES	N/A
⑬	CYLINDRICAL LOCK: SCHLAGE D SERIES	N/A
⑭	DEAD BOLT: SCHLAGE B SERIES	N/A
⑮	WEATHER STRIP: NATIONAL GUARD PRODUCTS #120NA	SECURED WITH DOUBLE ROW OF #6 X 1/2" SMS SCREWS @ 1" FROM EA. END & BALANCE @ 4" O.C.
⑯	THRESHOLD: NATIONAL GUARD PRODUCTS #950NA	EXTRUDED ALUMINUM 6063-T6, 0.078" THK. W/ NEOPRENE BULB
⑰	CAULKING: GE SILICONE II	N/A
⑱	DOOR END CHANNEL REINFORCEMENT	16 GAGE (.051" MIN.) GALVANNEAL STEEL
⑲	DOOR SURFACE CLOSER REINFORCEMENT	14 GAGE (.072" MIN.) x 3 1/2" x 1.6875 x 16.250" LONG, GALVANNEAL.
⑳	#161 LOCK EDGE REINFORCING	16 GAGE (.051" MIN.)
㉓	DEAD LOCK STRIKE TAB	14 GAGE (.072" MIN.) GALVANNEAL, ATTACHED TO STRIKE JAMB W/(3) 1/8"Ø PROJECTION WELDS
㉕	THRESHOLD ANCHOR	1/4"Ø ULTRACONS BY ELCO CONSTRUCTION PRODUCTS, 1 3/4" MIN. EMBEDMENT & 3" MIN. E.D @ f'c=3ksi CONCRETE SILL
㉖	MORTISE LOCK REINFORCEMENT	ANSI #A115.1 #86, 0.072"MIN.
㉘	Z ANCHOR	18 GAGE (.042") GALVANNEAL, W/ Fy= 33Ksi, Fu= 44Ksi
㉙	T STRAP ANCHOR DAYBAR # PT1-001A	18 GAGE (.042") GALVANNEAL, W/ Fy= 33Ksi, Fu= 44Ksi
㉚	STRIKE FOR DEAD BOLT ⑭	0.095" THICK, STEEL, NICKEL FINISH (SEE SHEET 8A FOR SIZES)
㉛	STRIKE FOR CYLINDRICAL LOCK ⑬	0.095" THICK, STEEL, NICKEL FINISH (SEE SHEET 8A FOR SIZES)
㉜	STRIKE FOR MORTISE LOCK ⑫	0.095" THICK, STEEL, NICKEL FINISH (SEE SHEET 8A FOR SIZES)

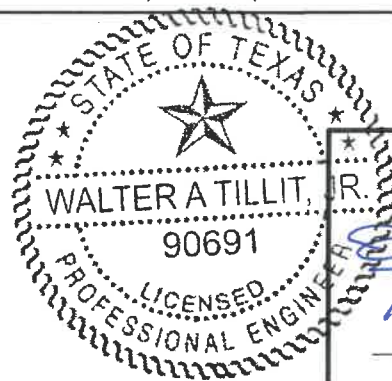

P.E. SEAL/SIGNATURE/DATE

WALTER A. TILLIT Jr P.E.
 PROFESSIONAL ENGINEER
 6355 N.W 36 STREET, STE. 305
 VIRGINIA GARDENS, FL 33166
 PHONE(305) 871-1530 FAX (305) 871-1531
 TEXAS LIC. # 90691
 FIRM REGISTRATION # F-13790

TEXAS DEPARTMENT OF INSURANCE - 2018					
SERIES LS20GA FLUSH COMMERCIAL STEEL INSWING DOOR W/SERIES "AS" 18GA STEEL FRAME				DRAWN BY: M.P.	
DAYBAR INDUSTRIES LTD 50 WEST DRIVE, BRAMPTON, ON CANADA, L6T 2J4 TEL: 905 625-8000 FAX: 905 625-4204				9/29/2021 DATE	
21-122 DRAWING No				21-122 DRAWING No	
REV. No	DESCRIPTION	DATE	REV. No	DESCRIPTION	DATE
1	OLD 17-053	9/29/21	3		
2			4		

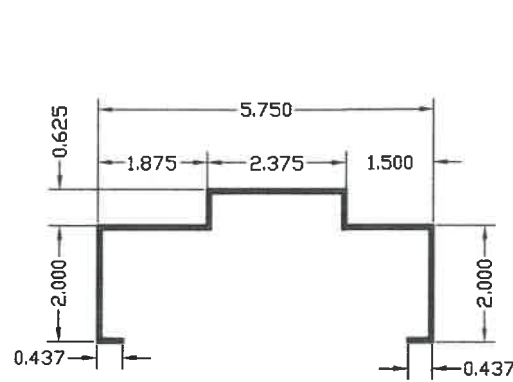

① AS 5 3/4" TYPICAL SECTION THROUGH

MATERIAL:
GAUGE 18 (0.042) MINIMUM
GALVANNEAL

①A AS 5 3/4" TYPICAL SECTION THROUGH

MATERIAL:
GAUGE 18 (0.042) MINIMUM
STAINLESS STEEL

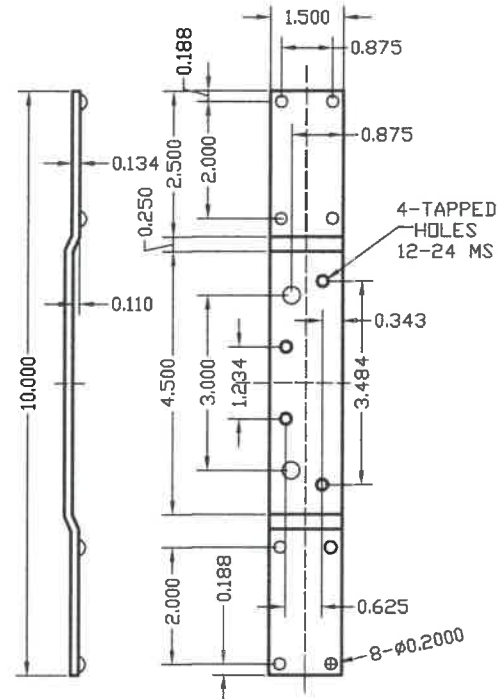

③ DOOR HINGE REINFORCING

MATERIAL:
GAUGE 10 (0.134) MINIMUM
GALVANNEAL

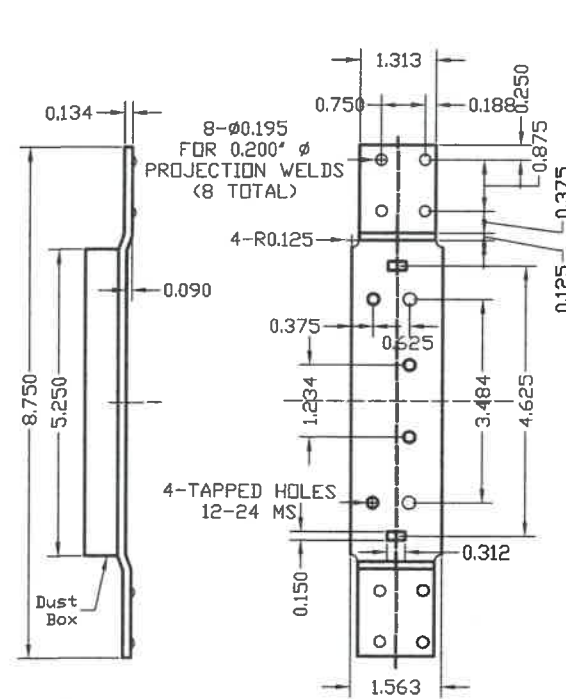

④ 4 1/2" FRAME HINGE REINFORCING

MATERIAL:
GAUGE 10 (0.134) MINIMUM
GALVANNEAL

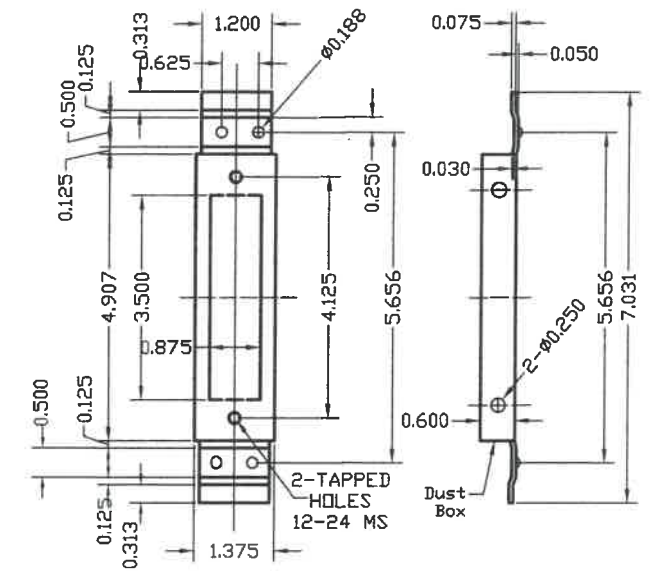

⑤ 4 7/8" STRIKE REINFORCEMENT FOR FRAME

MATERIAL:
GAUGE 12 (0.072) MINIMUM
GALVANNEAL

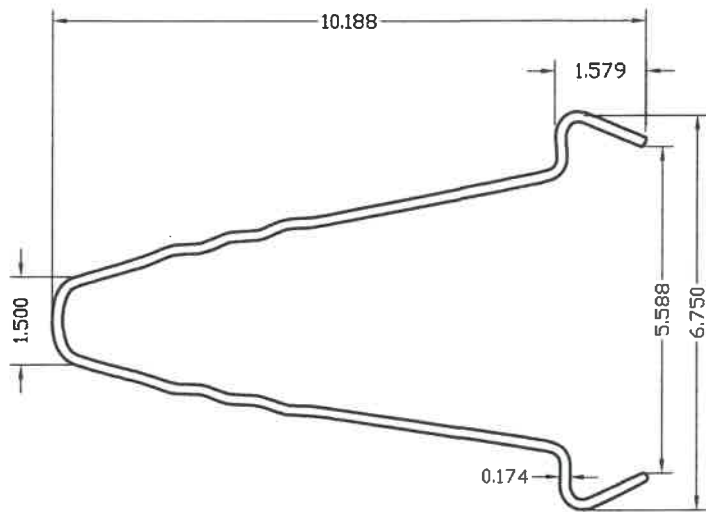

⑥ WIRE ANCHOR

STEEL WIRE ANCHORS
(0.134" DIA, 10 GAGE, 18 5/8"
EMBEDMENT LENGTH)
IN HORIZ.

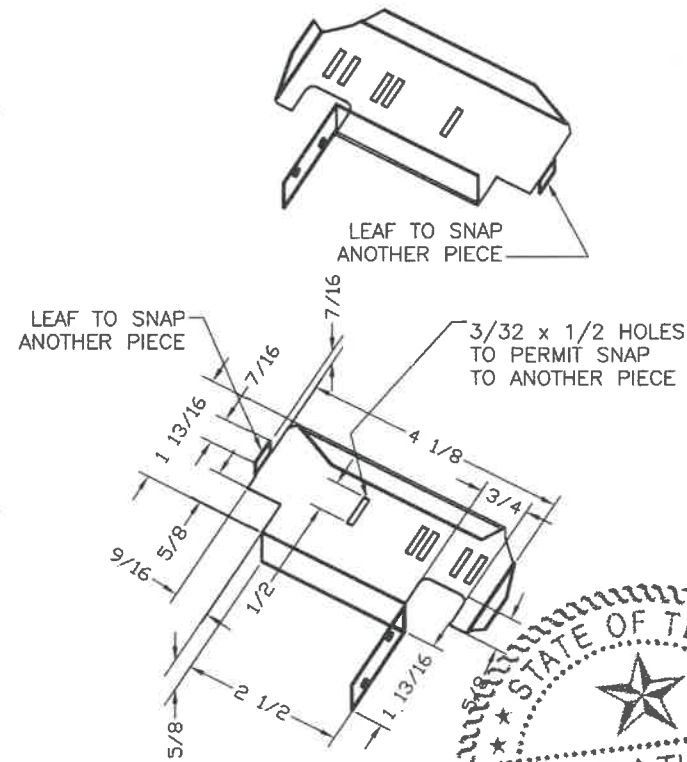

⑦ 2 PIECE SNAP-IN STUD ANCHOR

CLIPIN STUD ANCHOR MATERIAL: GAUGE
20 (0.032) ASTM A-653,
GALVANNEALED STEEL.

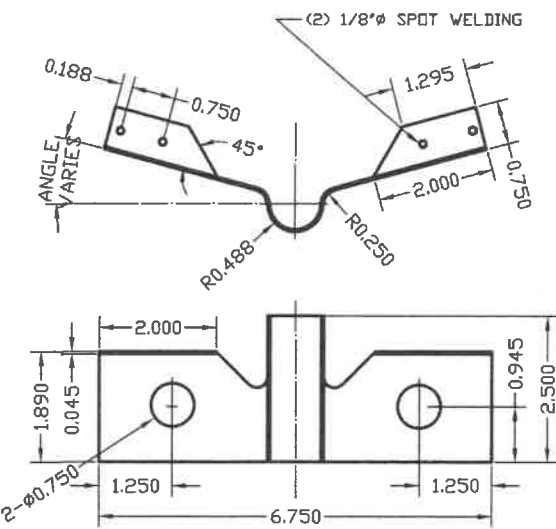

⑧A EMA BUTTERFLY ANCHOR (PART #PT1-008)

MATERIAL: 18 GA (0.042") SATIN COAT

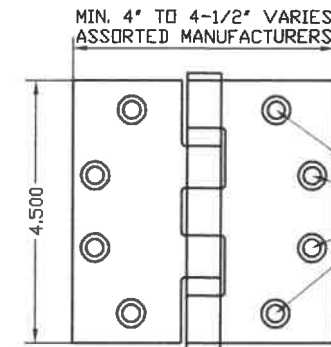

⑩ HINGE-HAGER

MATERIAL: 0.134"
STEEL, NICKEL FINISH

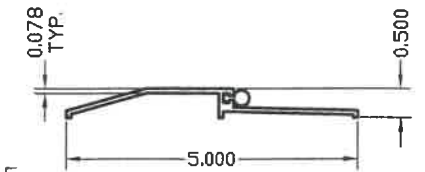

⑬ EXTRUDED ALUMINUM THRESHOLD NGP #950NA W/ NEOPRENE BULB

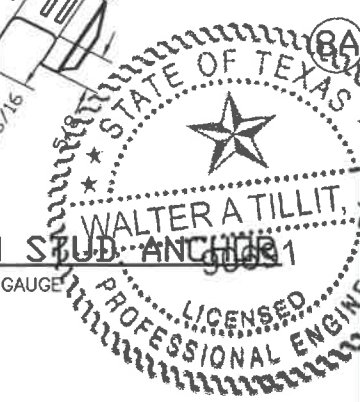

WALTER A. TILLIT, JR.
PROFESSIONAL ENGINEER
10/1/2021
P.E. SEAL/SIGNATURE/DATE

WALTER A. TILLIT Jr P.E.
PROFESSIONAL ENGINEER
6355 N.W 36 STREET, STE. 305
VIRGINIA GARDENS, FL 33166
PHONE(305) 871-1530 FAX (305) 871-1531
TEXAS LIC. # 90691
FIRM REGISTRATION # F-13790

TEXAS DEPARTMENT OF INSURANCE - 2018					
SERIES LS20GA FLUSH COMMERCIAL STEEL INSWING DOOR W/SERIES "AS" 18GA STEEL FRAME			DRAWN BY: M.P.		
DAYBAR INDUSTRIES LTD			9/29/2021 DATE		
50 WEST DRIVE, BRAMPTON, ON CANADA, L6T 2J4 TEL: 905 625-8000 FAX: 905 625-4204			21-122 DRAWING No		
REV. No	DESCRIPTION	DATE	REV. No	DESCRIPTION	DATE
1	OLD 17-053	9/29/21	3		
2			4		

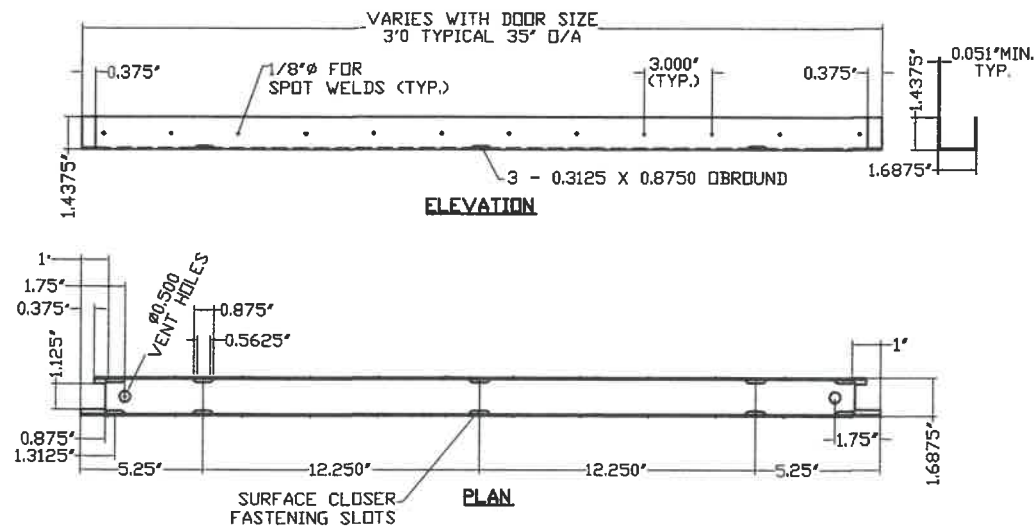

18 DOOR END CHANNEL REINFORCEMENT

MATERIAL:
16 GAUGE (0.051) MINIMUM
GALVANNEAL

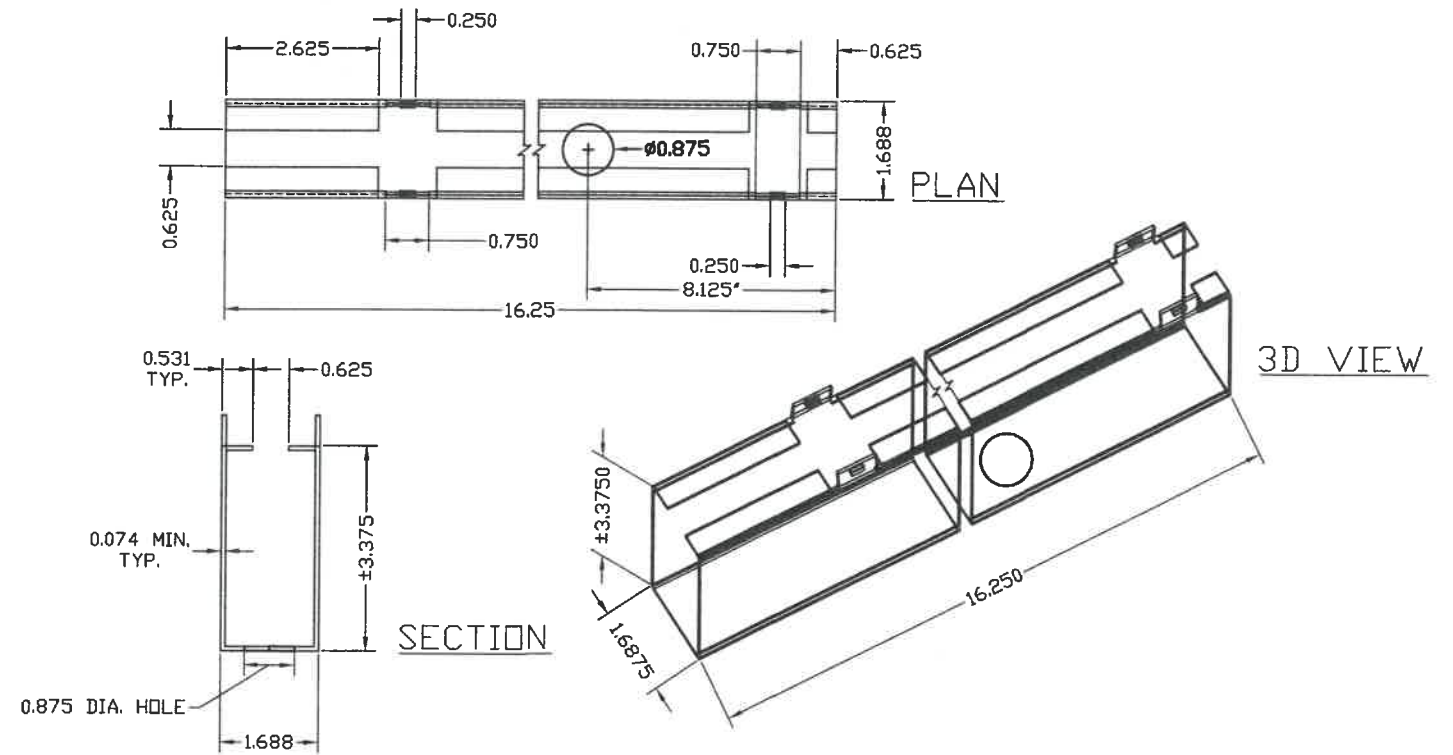

19 DOOR SURFACE CLOSER REINFORCING

MATERIAL:
14 GAUGE (0.072)
MINIMUM GALVANNEAL

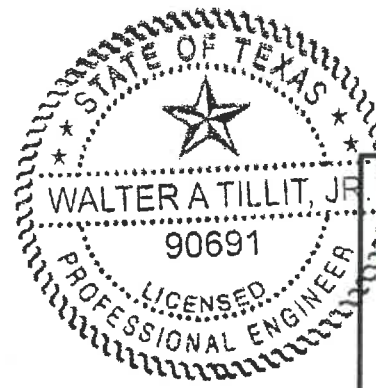

Walter A. Tillit, Jr.
10/1/2021
P.E. SEAL/SIGNATURE/DATE

WALTER A. TILLIT Jr P.E.
PROFESSIONAL ENGINEER
6355 N.W 36 STREET, STE. 305
VIRGINIA GARDENS, FL 33166
PHONE(305) 871-1530 FAX (305) 871-1531
TEXAS LIC. # 90691
FIRM REGISTRATION # F-13790

TEXAS DEPARTMENT OF INSURANCE - 2018					
SERIES LS20GA FLUSH COMMERCIAL STEEL INSWING DOOR W/SERIES "AS" 18GA STEEL FRAME				DRAWN BY: M.P.	
DAYBAR INDUSTRIES LTD				9/29/2021 DATE	
50 WEST DRIVE, BRAMPTON, ON CANADA, L6T 2J4 TEL: 905 625-8000 FAX: 905 625-4204				21-122 DRAWING No	
REV. No	DESCRIPTION	DATE	REV. No	DESCRIPTION	DATE
1	OLD 17-053	9/29/21	3		
2			4		

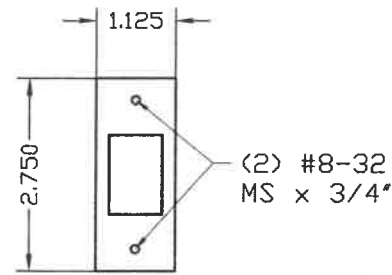

30 STRIKE FOR DEAD BOLT 14
 MATERIAL: (0.095) Steel, Nickel Finish

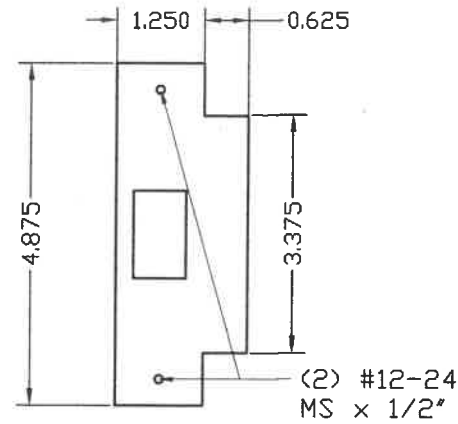

31 STRIKE FOR CYLINDRICAL LOCK 13
 MATERIAL: (0.095) Steel, Nickel Finish

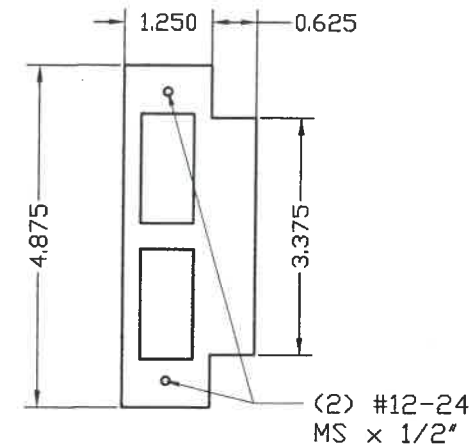

32 STRIKE FOR MORTISE LOCK 12
 MATERIAL: (0.095) Steel, Nickel Finish

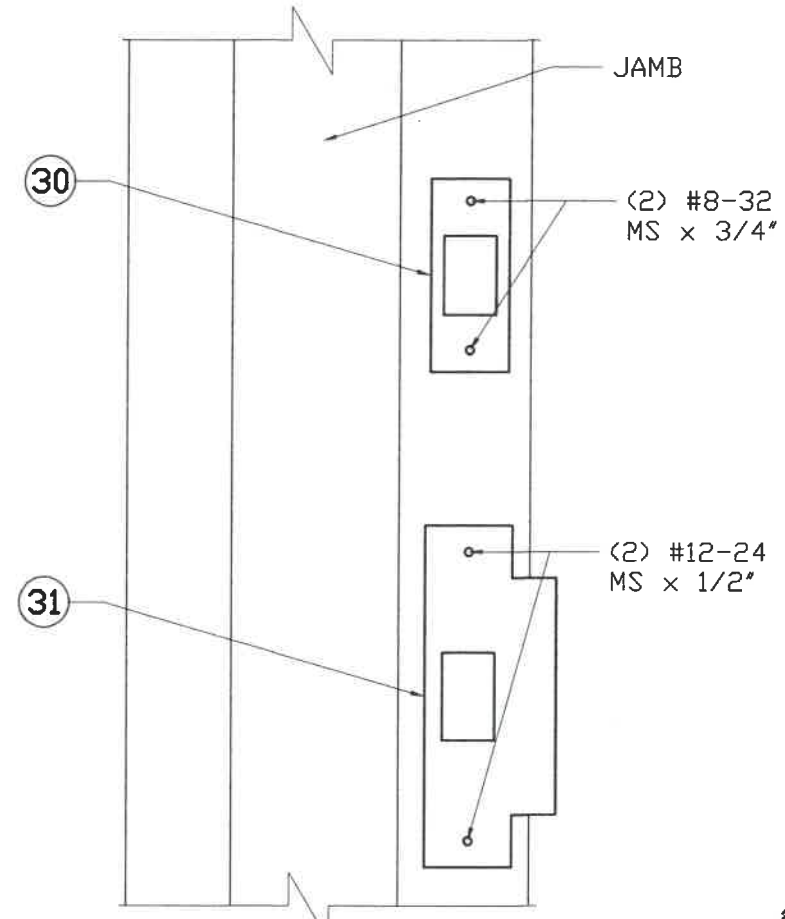

STRIKE DETAIL ELEVATION
 Latch & Deadbolt

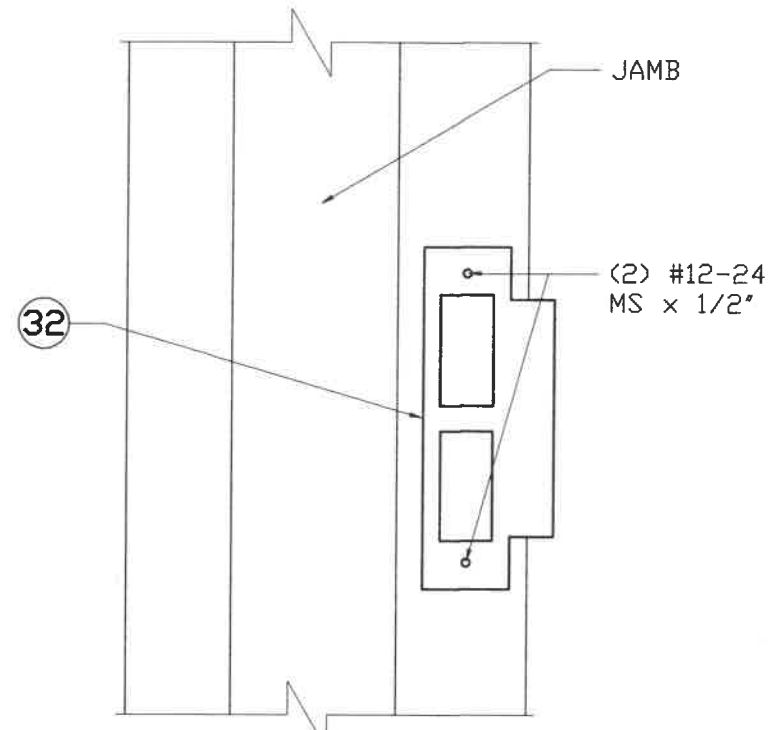

STRIKE DETAIL ELEVATION
 Mortised Device Latch

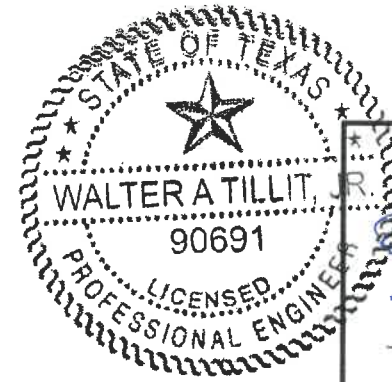

Walter A. Tillit, Jr.
 10/1/2021
 P.E. SEAL/SIGNATURE/DATE

WALTER A. TILLIT Jr P.E.
 PROFESSIONAL ENGINEER
 6355 N.W 36 STREET, STE. 305
 VIRGINIA GARDENS, FL 33166
 PHONE(305) 871-1530 FAX (305) 871-1531
 TEXAS LIC. # 90691
 FIRM REGISTRATION # F-13790

TEXAS DEPARTMENT OF INSURANCE - 2018					
SERIES LS20GA FLUSH COMMERCIAL STEEL INSWING DOOR W/SERIES "AS" 18GA STEEL FRAME				DRAWN BY: M.P.	
DAYBAR INDUSTRIES LTD				9/29/2021 DATE	
50 WEST DRIVE, BRAMPTON, ON CANADA, L6T 2J4 TEL: 905 625-8000 FAX: 905 625-4204				21-122 DRAWING No	
REV. No	DESCRIPTION	DATE	REV. No	DESCRIPTION	DATE
1	OLD 17-055	9/29/21	3		
2			4		

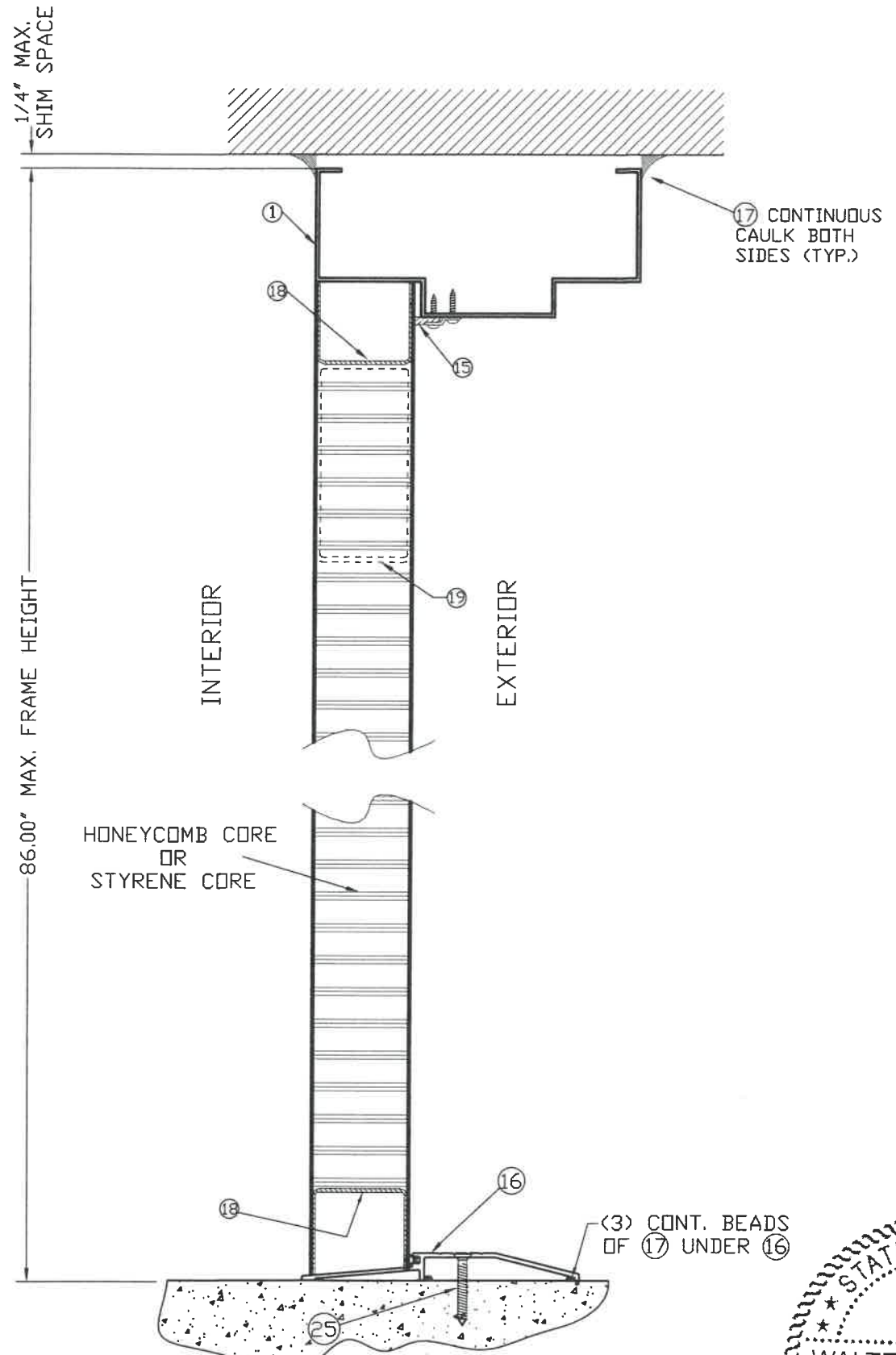

f'c=3ksi
CONCRETE REQ'D.

**SECTIONS A1-A1 & A2-A2
AT DOOR PANEL/FRAME**

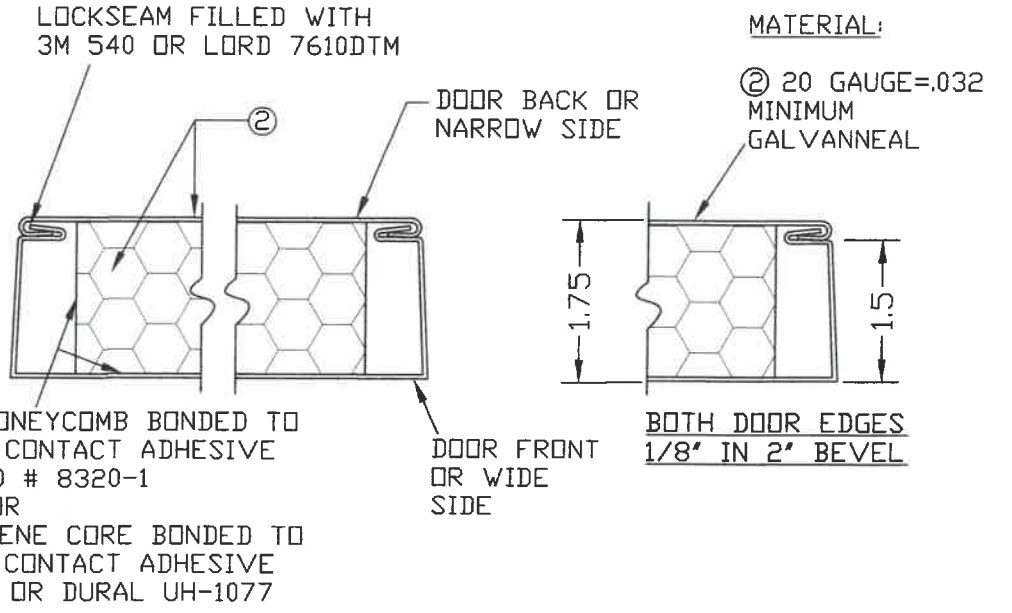

**DOOR SECTION THROUGH EDGE SEAM,
DETAIL X**

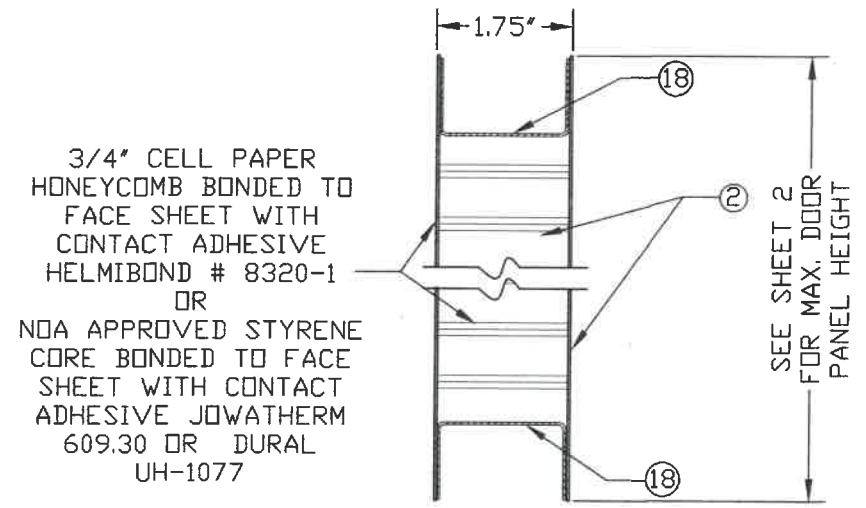

**VERTICAL SECTION AT DOOR PANEL
DOOR PANEL CONSTRUCTION**

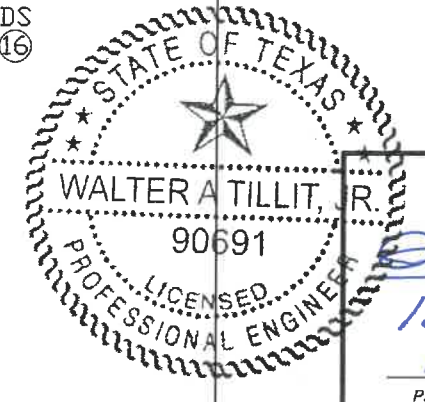

Walter A. Tillit, Jr.
10/1/2021
P.E. SEAL/SIGNATURE/DATE

WALTER A. TILLIT Jr P.E.
PROFESSIONAL ENGINEER
6355 N.W 36 STREET, STE. 305
VIRGINIA GARDENS, FL 33166
PHONE(305) 871-1530 FAX (305) 871-1531
TEXAS LIC. # 90691
FIRM REGISTRATION # F-13790

TEXAS DEPARTMENT OF INSURANCE - 2018					
SERIES LS20GA FLUSH COMMERCIAL STEEL INSWING DOOR W/SERIES "AS" 18GA STEEL FRAME				DRAWN BY: M.P.	
DAYBAR INDUSTRIES LTD				9/29/2021 DATE	
50 WEST DRIVE, BRAMPTON, ON CANADA, L7T 2J4 TEL: 905 625-8000 FAX: 905 625-4204				21-122 DRAWING No	
REV. No	DESCRIPTION	DATE	REV. No	DESCRIPTION	DATE
1	OLD 17-053	9/29/21	3		
2			4		

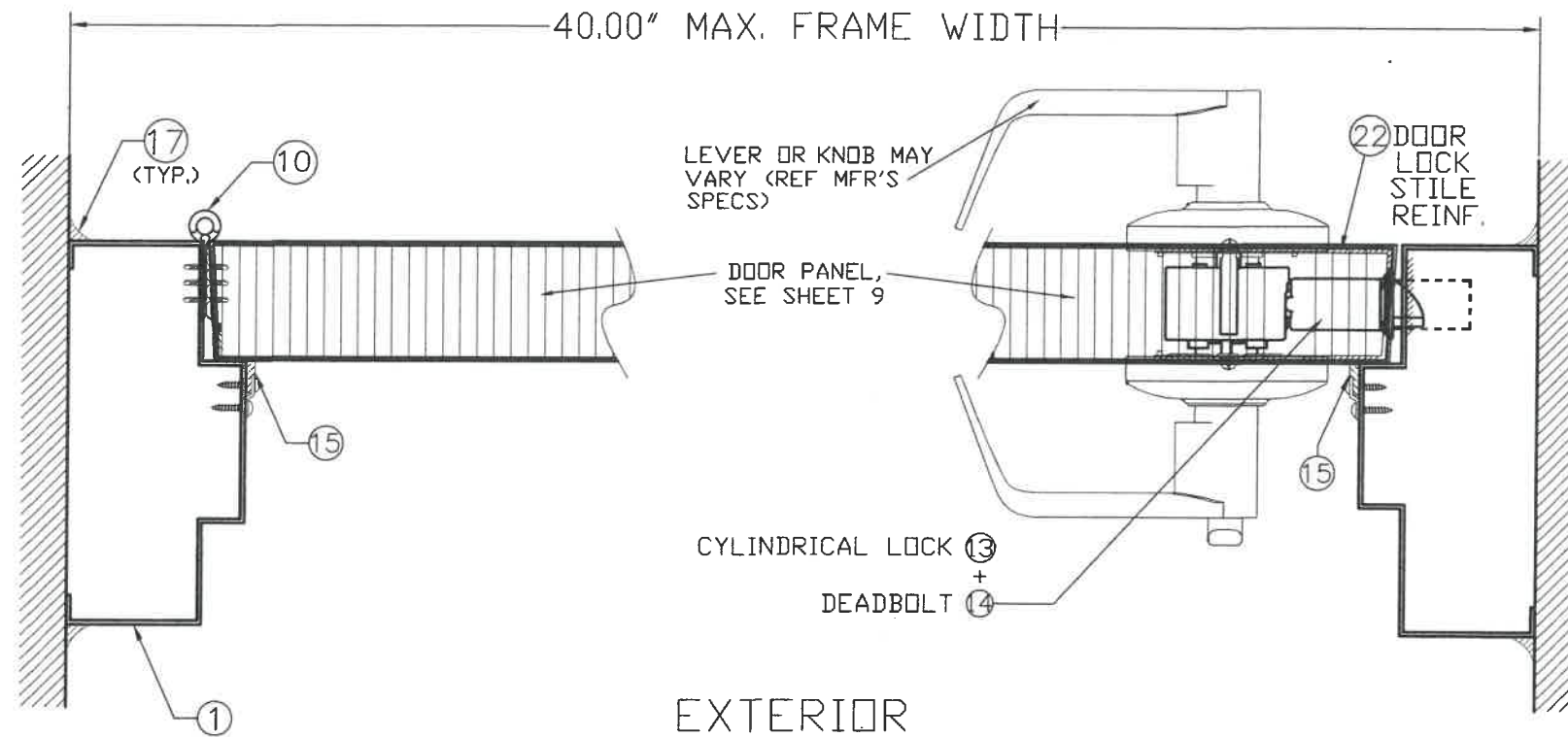

SECTION B1-B1

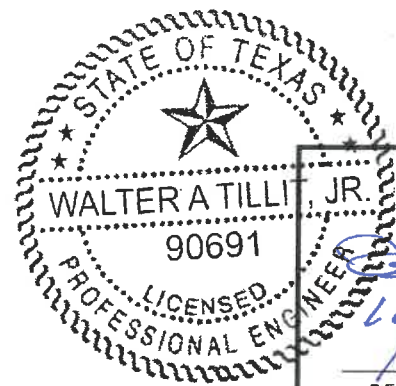

Walter A. Tillit, Jr.
 P.E. SEAL/SIGNATURE/DATE

WALTER A. TILLIT Jr P.E.
 PROFESSIONAL ENGINEER
 6355 N.W 36 STREET, STE. 305
 VIRGINIA GARDENS, FL 33166
 PHONE(305) 871-1530 FAX (305) 871-1531
 TEXAS LIC. # 90691
 FIRM REGISTRATION # F-13790

TEXAS DEPARTMENT OF INSURANCE - 2018					
SERIES LS20GA FLUSH COMMERCIAL STEEL INSWING DOOR W/SERIES "AS" 18GA STEEL FRAME				DRAWN BY: M.P.	
DAYBAR INDUSTRIES LTD				9/29/2021 DATE	
50 WEST DRIVE, BRAMPTON, ON CANADA, L6T 2J4 TEL: 905 625-8000 FAX: 905 625-4204				21-122 DRAWING No	
REV. No	DESCRIPTION	DATE	REV. No	DESCRIPTION	DATE
1	OLD 17-053	9/29/21	3		
2			4		

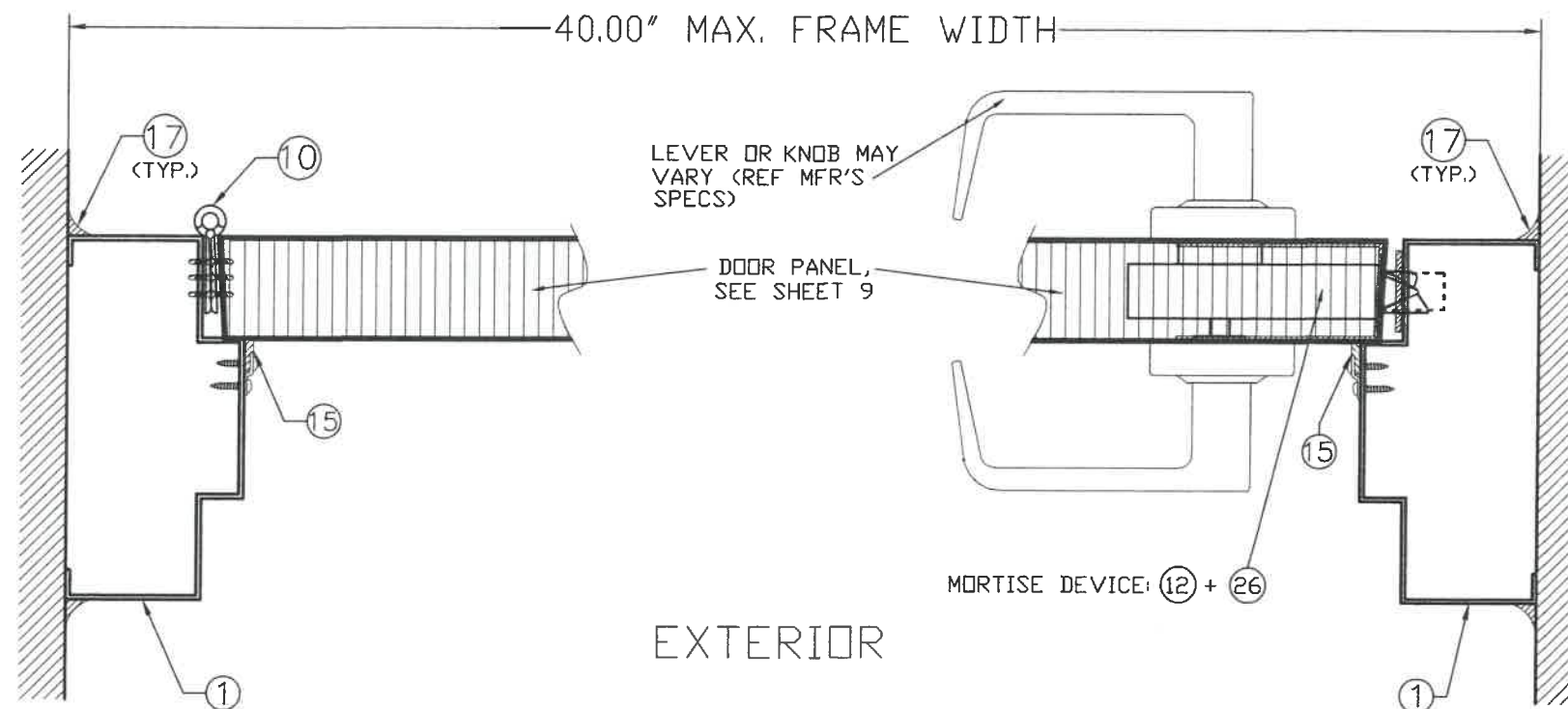

SECTION B2-B2

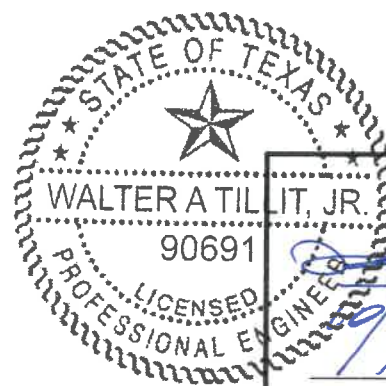

[Handwritten Signature]
 P.E. SEAL/SIGNATURE/DATE

WALTER A. TILLIT Jr P.E.
 PROFESSIONAL ENGINEER
 6355 N.W 36 STREET, STE. 305
 VIRGINIA GARDENS, FL 33166
 PHONE(305) 871-1530 FAX (305) 871-1531
 TEXAS LIC. # 90691
 FIRM REGISTRATION # F-13790

TEXAS DEPARTMENT OF INSURANCE - 2018					
SERIES LS20GA FLUSH COMMERCIAL STEEL INSWING DOOR W/SERIES "AS" 18GA STEEL FRAME				DRAWN BY: M.P.	
DAYBAR INDUSTRIES LTD				9/29/2021 DATE	
50 WEST DRIVE, BRAMPTON, ON CANADA, L6T 2J4 TEL: 905 625-8000 FAX: 905 625-4204				21-122 DRAWING No	
REV. No	DESCRIPTION	DATE	REV. No	DESCRIPTION	DATE
1	OLD 17-053	9/29/21	3		
2			4		

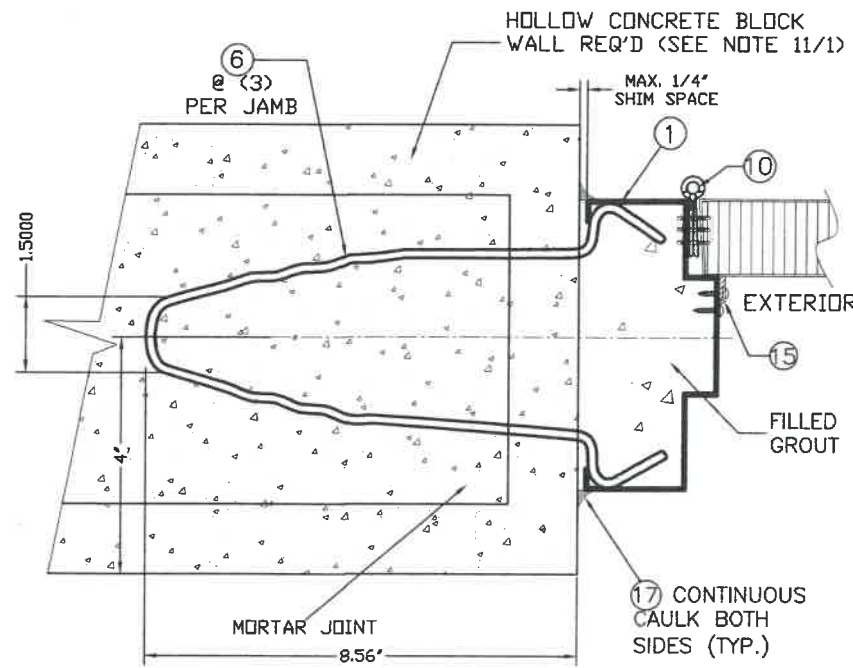

SECTION C

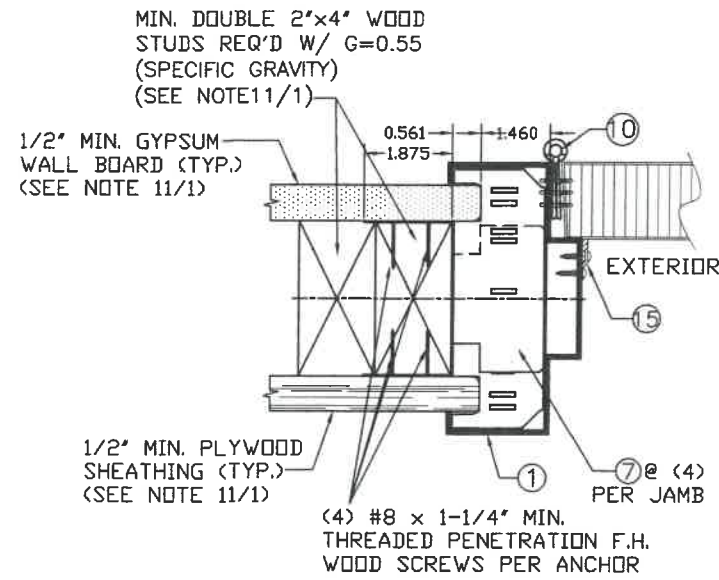

SECTION E

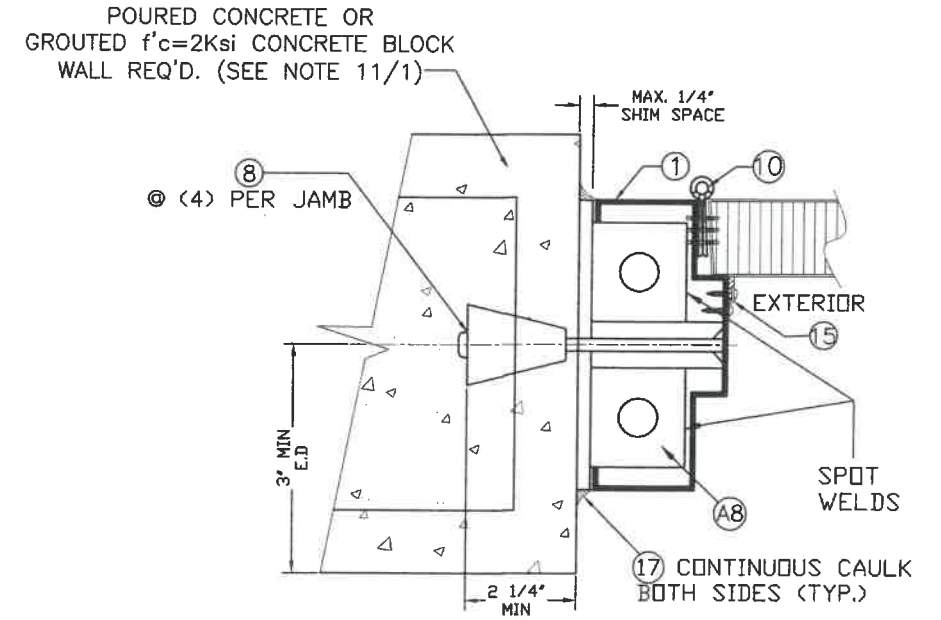

SECTION F

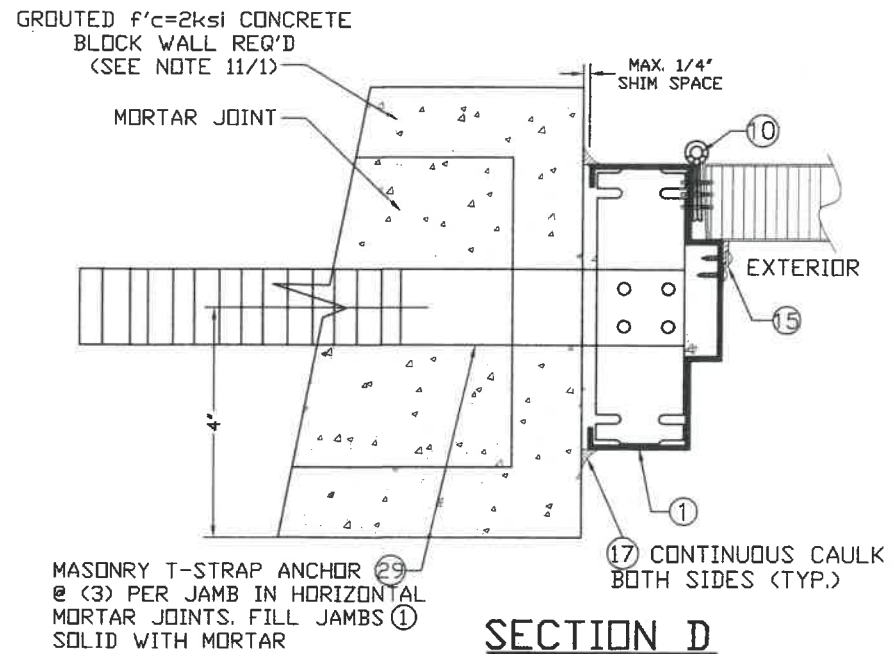

SECTION D

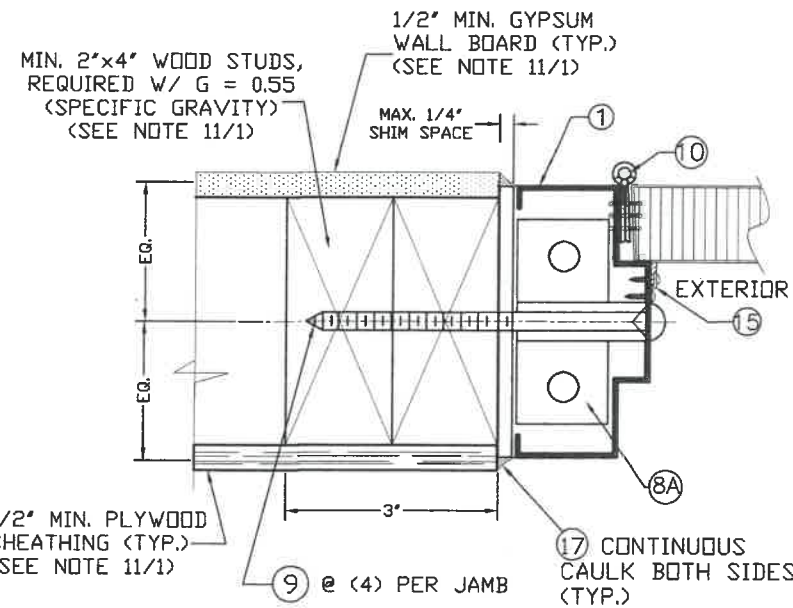

SECTION G

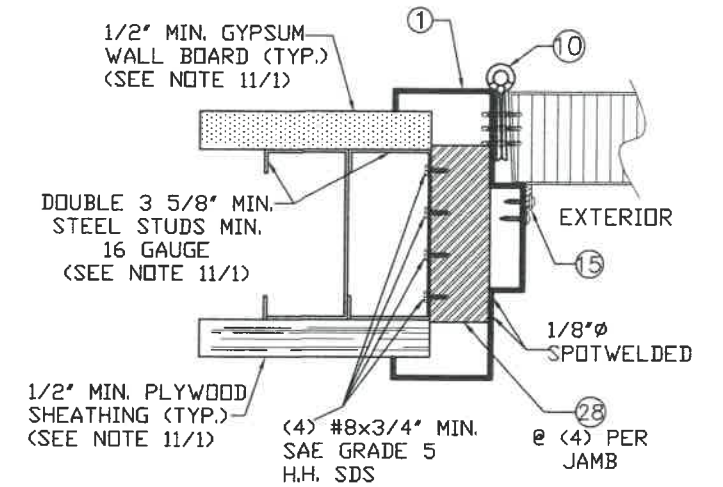

SECTION H

CASE 1

CASE 2

ANCHORAGE DETAIL AT JAMBS

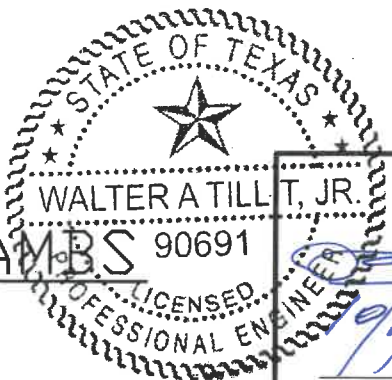

WALTER A. TILLIT Jr P.E.
 PROFESSIONAL ENGINEER
 6355 N.W 36 STREET, STE. 305
 VIRGINIA GARDENS, FL 33166
 PHONE(305) 871-1530 FAX (305) 871-1531
 TEXAS LIC. # 90691
 FIRM REGISTRATION # F-13790

TEXAS DEPARTMENT OF INSURANCE - 2018					
SERIES LS20GA FLUSH COMMERCIAL STEEL INSWING DOOR W/SERIES "AS" 18GA STEEL FRAME				DRAWN BY: M.P.	
DAYBAR INDUSTRIES LTD				9/29/2021 DATE	
50 WEST DRIVE, BRAMPTON, ON CANADA, L6T 2J4 TEL: 905 625-8000 FAX: 905 625-4204				21-122 DRAWING No	
REV. No	DESCRIPTION	DATE	REV. No	DESCRIPTION	DATE
1	OLD 17-055	9/29/21	3		
2			4		

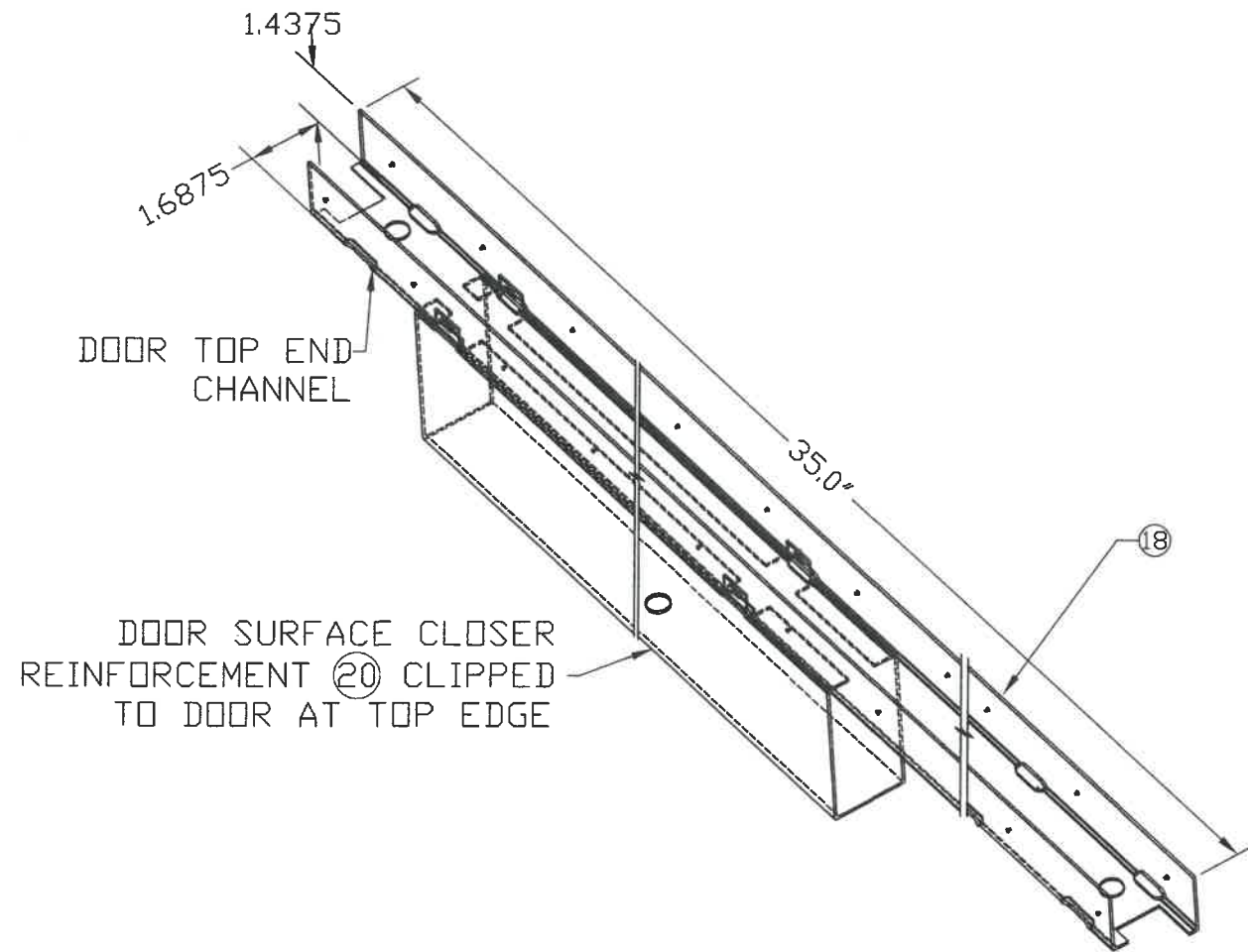

DOOR SURFACE CLOSER REINFORCEMENT (20)
AND END CHANNEL (18) ASSEMBLY DETAIL
DETAIL Z

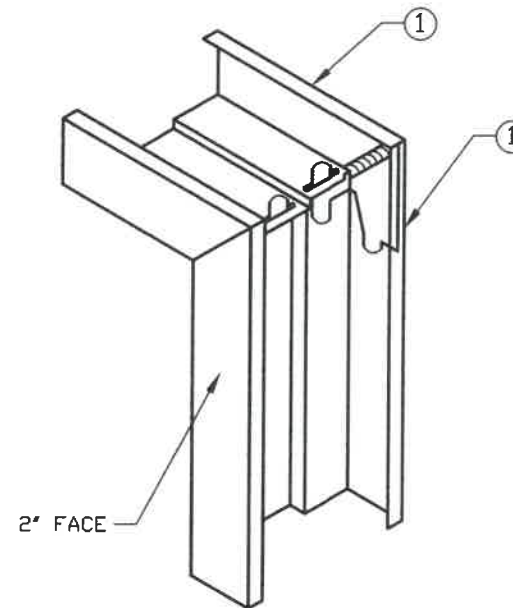

1. DIEMITERED CORNER CONT. WELDED INSIDE FACES & AT RETURNS
2. CAULK COMPLETE INSIDE CORNER WITH GE SILICONE II (17)

DETAIL Y

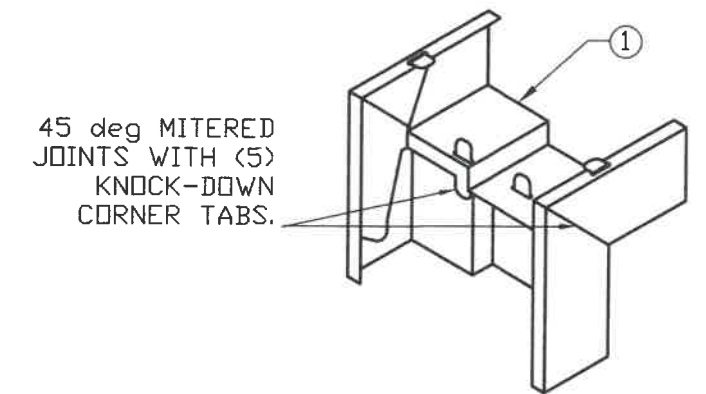

45 deg MITERED JOINTS WITH (5) KNOCK-DOWN CORNER TABS.

FRAME CORNER: KD 3 PIECE ASSEMBLED AND CAULKED W/ (17)

DETAIL Y1

CORNER DETAILS Y, Y1

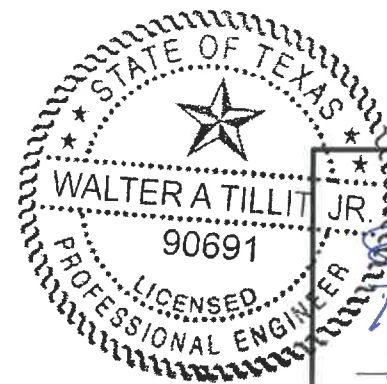

Walter A. Tillit Jr.
 P.E. SEAL/SIGNATURE/DATE

WALTER A. TILLIT Jr P.E.
 PROFESSIONAL ENGINEER
 6355 N.W 36 STREET, STE. 305
 VIRGINIA GARDENS, FL 33166
 PHONE(305) 871-1530 FAX (305) 871-1531
 TEXAS LIC. # 90691
 FIRM REGISTRATION # F-13790

TEXAS DEPARTMENT OF INSURANCE - 2018					
SERIES LS20GA FLUSH COMMERCIAL STEEL INSWING DOOR W/SERIES "AS" 18GA STEEL FRAME				DRAWN BY: M.P.	
DAYBAR INDUSTRIES LTD 50 WEST DRIVE, BRAMPTON, ON CANADA, L6T 2J4 TEL: 905 625-8000 FAX: 905 625-4204				9/29/2021 DATE	
				21-122 DRAWING No	
REV. No	DESCRIPTION	DATE	REV. No	DESCRIPTION	DATE
1	OLD 17-053	9/29/21	3		
2			4		