

Vision Hollow Metal Limited

400 Zenway Blvd. Unit #1
Woodbridge, ON L4H OS7

LS2075 STEEL DOOR OUTSWING "IMPACT"

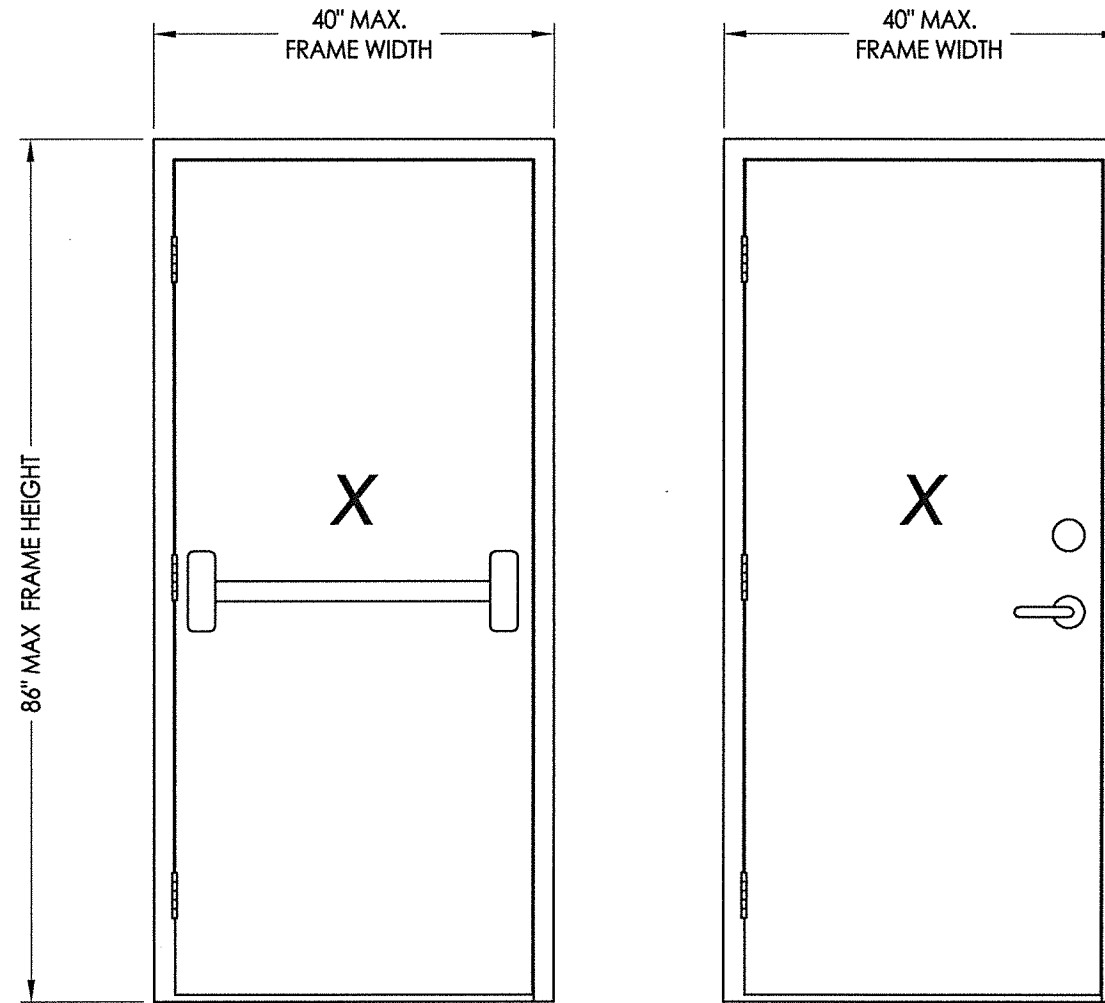

PANIC BAR EXIT DEVICE

CYLINDRICAL LOCK & DEADBOLT

EVALUATED FOR USE IN THE STATE OF TEXAS

TDI DR-895

The Steel Door system described herein complies with the 2018 International Residential Code (IRC), Sections R301 & R609 and the 2018 International Building Code (IBC), Sections 1404.13, 1609, 1709.5, 2403 and 2404 subject to the following conditions:

1. Anchors shall be as listed and spaced as shown in the details. Anchor embedment to base material shall be beyond wall dressing or stucco.
2. This system has been tested and evaluated as a large missile impact protective system for installation in areas that require wind borne debris protection. This product meets missile level "D" as defined in ASTM E 1996.
3. Allowable design pressure requirements must be equal to or less than the design pressure rating shown in the design pressure chart, sheet 1 of this drawing.
4. Conditions not covered by this drawing are subject to further engineering analysis.

TABLE OF CONTENTS

SHEET#	DESCRIPTION
1	Typical elevations, design pressures, & general notes
2	Door panel details
3	Elevations
4	Horizontal cross sections
5	Vertical cross sections
6	Frame anchoring
7	Frame anchoring
8	Bill of materials and components

MAX. OVERALL DIMENSION	DESIGN PRESSURE (PSF)	
	POSITIVE	NEGATIVE
40.0" X 86.0"	+75.0	-75.0

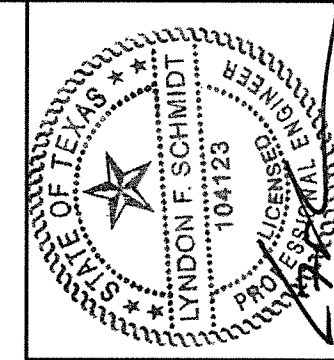

Documents Prepared By: Lyndon F. Schmidt, P.E.
TEXAS P.E. #104123

RW BUILDING CONSULTANTS, INC.
P.O. Box 230 Valrico FL 33595
Phone No.: 813.659.9197

TEXAS BOARD OF PROFESSIONAL ENGINEERS
CERTIFICATE OF REGISTRATION # F-11852

PRODUCT: VISION HOLLOW METAL

PART OR ASSEMBLY:
TYPICAL ELEVATIONS, DESIGN PRESSURES & GENERAL NOTES

NO.	DATE	DESCRIPTION	BY
1	11/3/21	UPDATE TO 2018 IBC/IRC	LFS
REVISIONS			

DATE: 6/06/17

SCALE: N.T.S.

DWG. BY: JK

CHK. BY: LFS

DRAWING NO.: TX-4703

SHEET 1 OF 8

Z:\Clients\Vision Hollow Metal Permanent\B - Texas Dept of Ins\TDI - DR-895 8'0" Opaque Comm. Steel Doors\C - Drawings\TX-4703.dwg

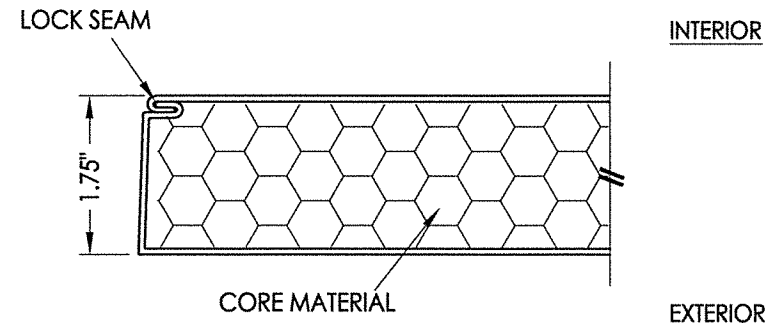

1
2 **HORIZONTAL CROSS SECTION**

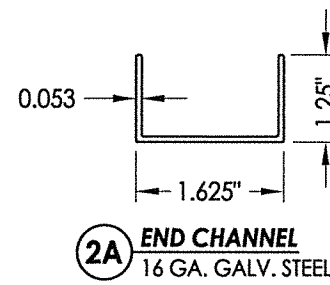

2A **END CHANNEL**
16 GA. GALV. STEEL

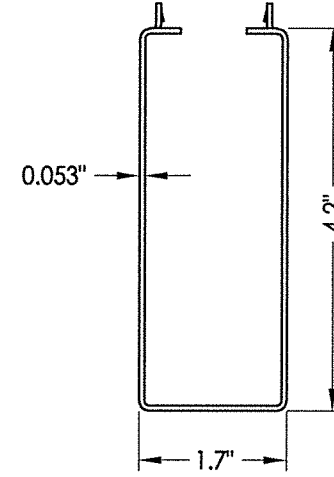

2B **CLOSER BOX**
16 GA. GALV. STEEL

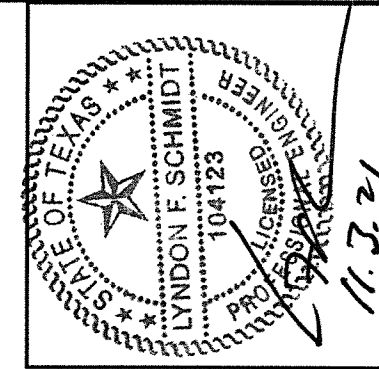

Documents Prepared By: Lyndon F. Schmidt, P.E.
TEXAS P.E. #104123

RW BUILDING CONSULTANTS, INC.
P.O. Box 230 Valrico FL 33595
Phone No.: 813.659.9197
TEXAS BOARD OF PROFESSIONAL ENGINEERS
CERTIFICATE OF REGISTRATION # F-11852

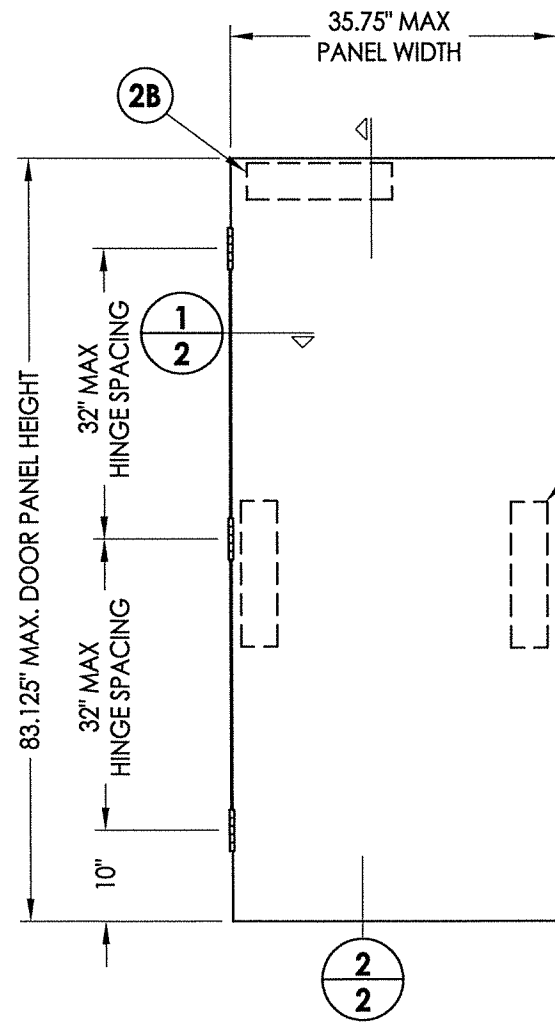

40 **OPAQUE DOOR PANEL**
7'-0" Door w/ Rim Panic Exit Device

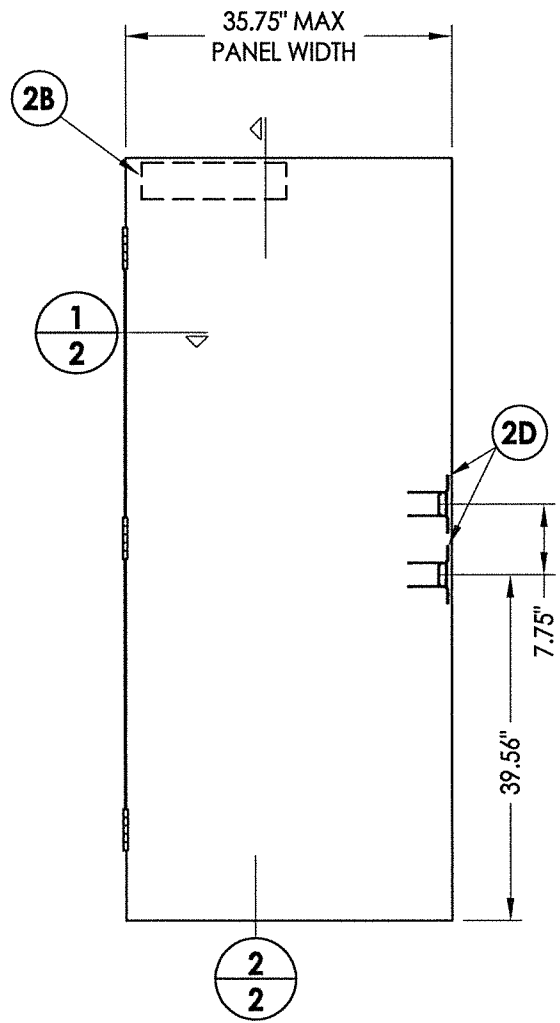

40 **OPAQUE DOOR PANEL**
7'-0" Door w/ Cylindrical Lock & Deadbolt

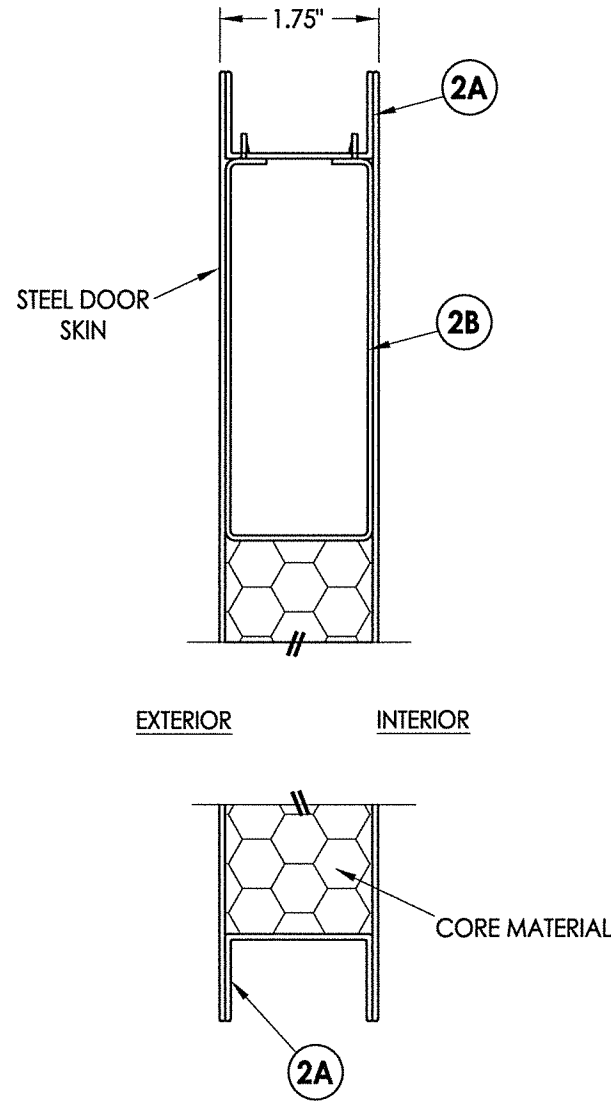

2
2 **VERTICAL CROSS SECTION**

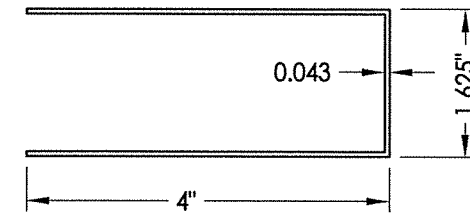

2C **RIM PANIC BOX**
18 GA. GALV. STEEL

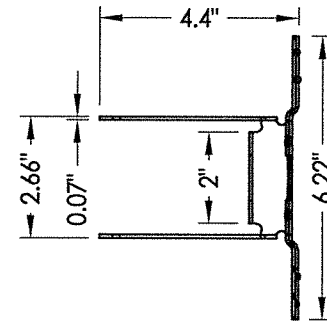

2D **CYLINDRICAL LOCK REINFORCEMENT**
18 GA. GALV. STEEL

PRODUCT:	VISION HOLLOW METAL	
PART OR ASSEMBLY:	DOOR PANEL DETAILS	
NO.	DATE	BY
1	11/3/21	LFS
UPDATE TO 2018 IBC/IRC		
REVISIONS		

DATE:	6/06/17
SCALE:	N.T.S.
DWG. BY:	JK
CHK. BY:	LFS
DRAWING NO.:	TX-4703
SHEET	2 OF 8

STEEL DOOR SKIN: 20 GA. (MIN. 0.032" THK.) GALV. STEEL (F_y = 50,500 PSI MIN.)
CORE MATERIAL: EPS FOAM (POLYSTYRENE - 1.0 PCF MIN. DENSITY)

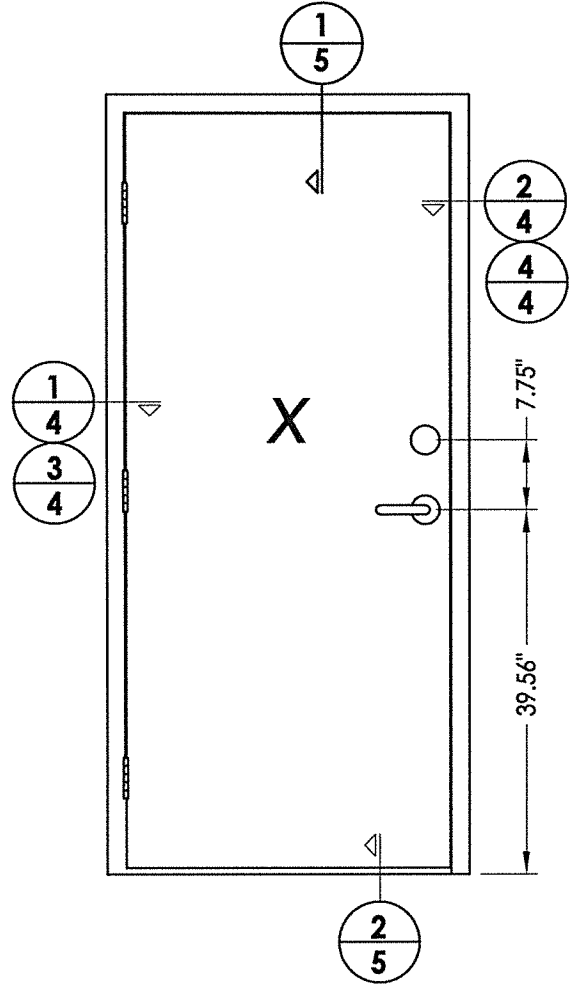

LOCK HARDWARE
 CYLINDRICAL LOCK: SCHLAGE AL53PD
 DEADBOLT: SCHLAGE B660P

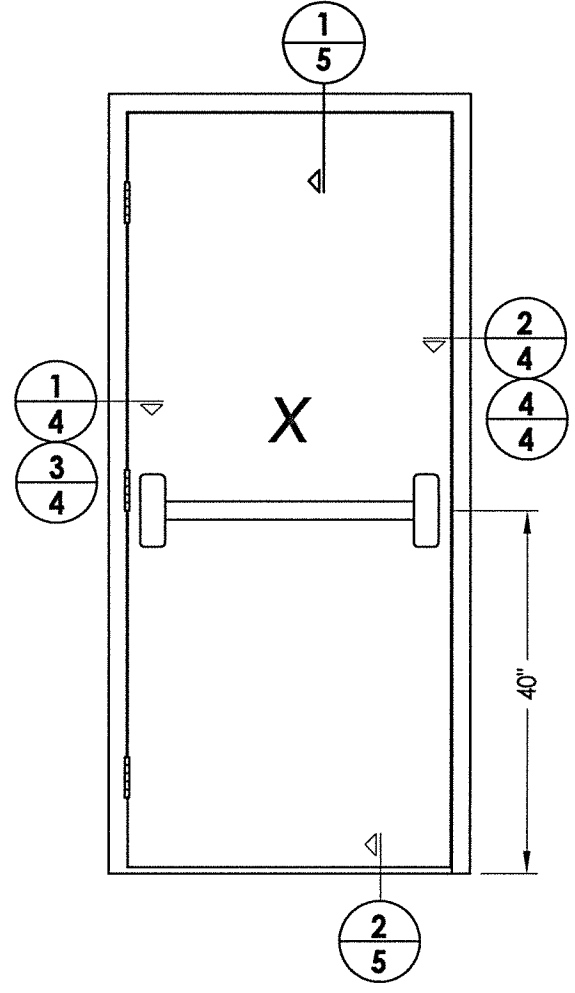

LOCK HARDWARE
 RIM PANIC EXIT DEVICE: DESIGN HARDWARE 2000 SERIES

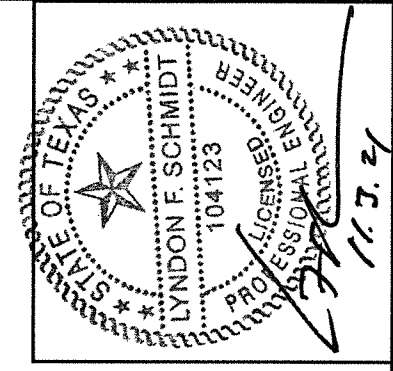

Documents Prepared By: Lyndon F. Schmidt, P.E.
 TEXAS P.E. #104123

RW BUILDING CONSULTANTS, INC.
 P.O. Box 230 Valrico FL 33595
 Phone No.: 813.659.9197

TEXAS BOARD OF PROFESSIONAL ENGINEERS
 CERTIFICATE OF REGISTRATION # F-11852

PRODUCT: VISION HOLLOW METAL
 PART OR ASSEMBLY: ELEVATIONS

REVISIONS	
NO.	DATE
1	11/3/21
	UPDATE TO 2018 IBC/IRC
	LFS
	BY

DATE: 6/06/17
 SCALE: N.T.S.
 DWG. BY: JK
 CHK. BY: LFS
 DRAWING NO.: TX-4703
 SHEET 3 OF 8

Z:\Clients\Vision Hollow Metal Permanent\B - Texas Dept of Ins\TDI - DR-895 80" Opaque Comm. Steel Doors\C - Drawings\TX-4703.dwg

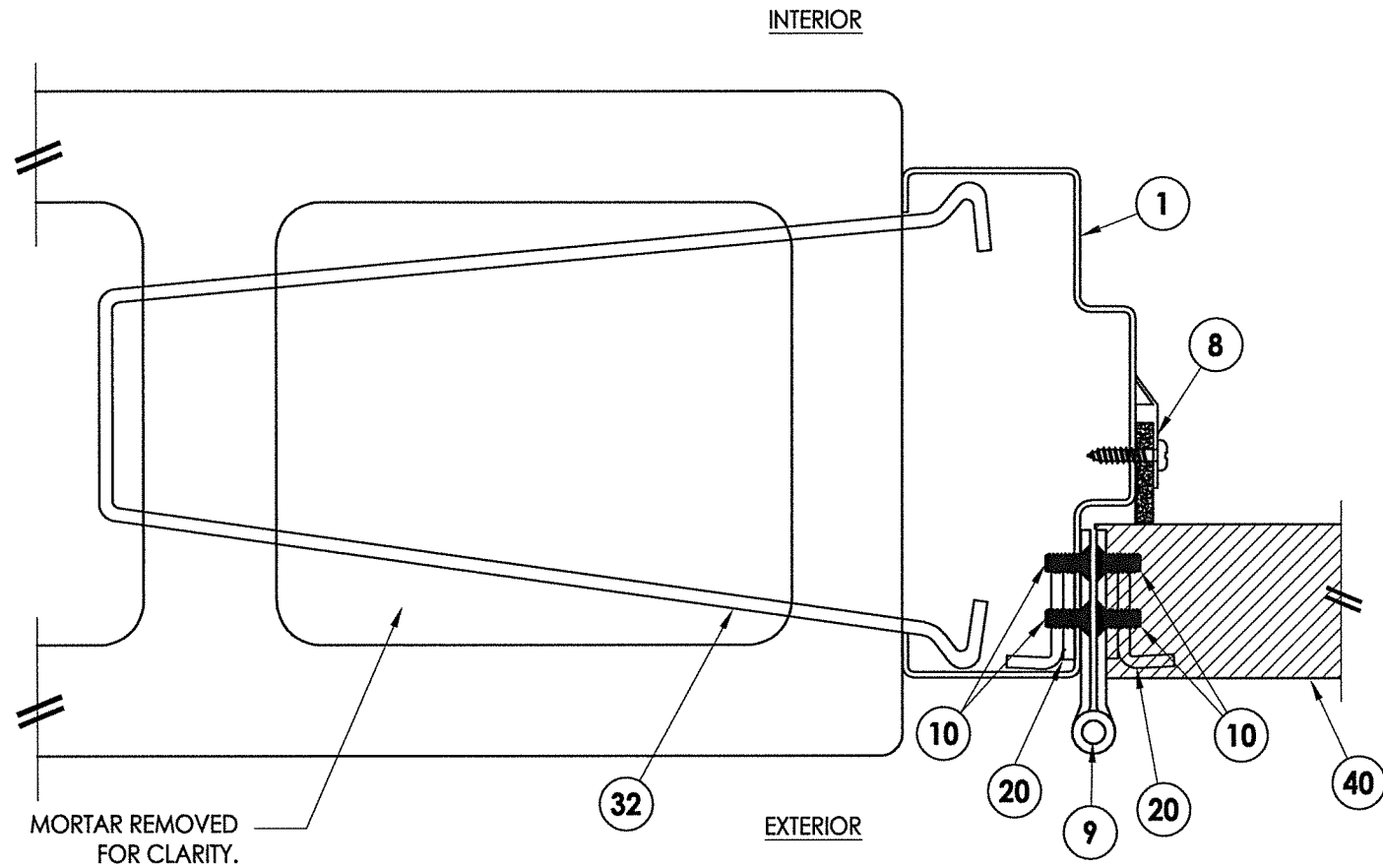

1 HORIZONTAL CROSS SECTION
4 Shown w/ Masonry Wire Anchor

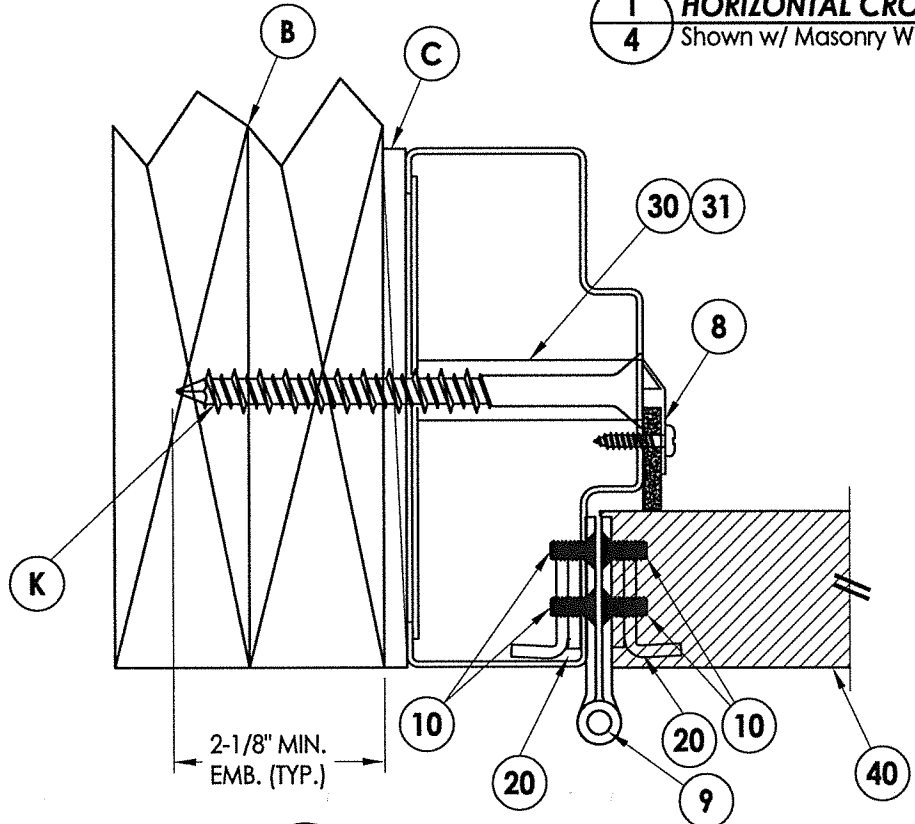

3 HORIZONTAL CROSS SECTION
4 Shown w/ Wood Stud Anchor

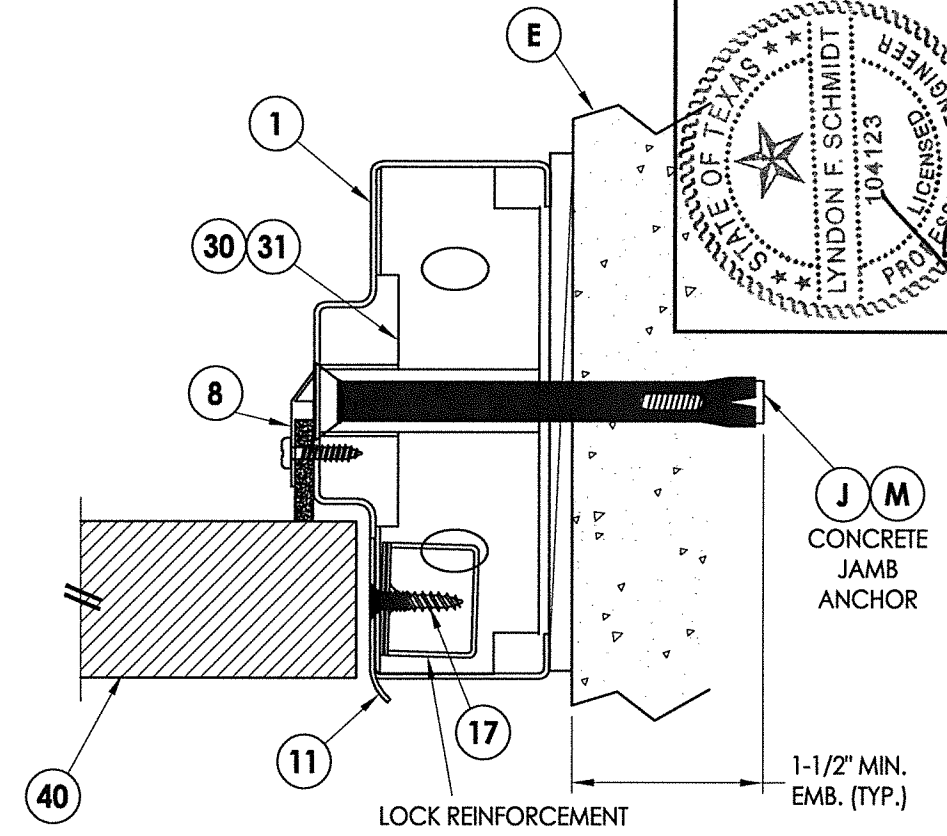

2 HORIZONTAL CROSS SECTION
4 Shown w/ Concrete Jamb Anchor

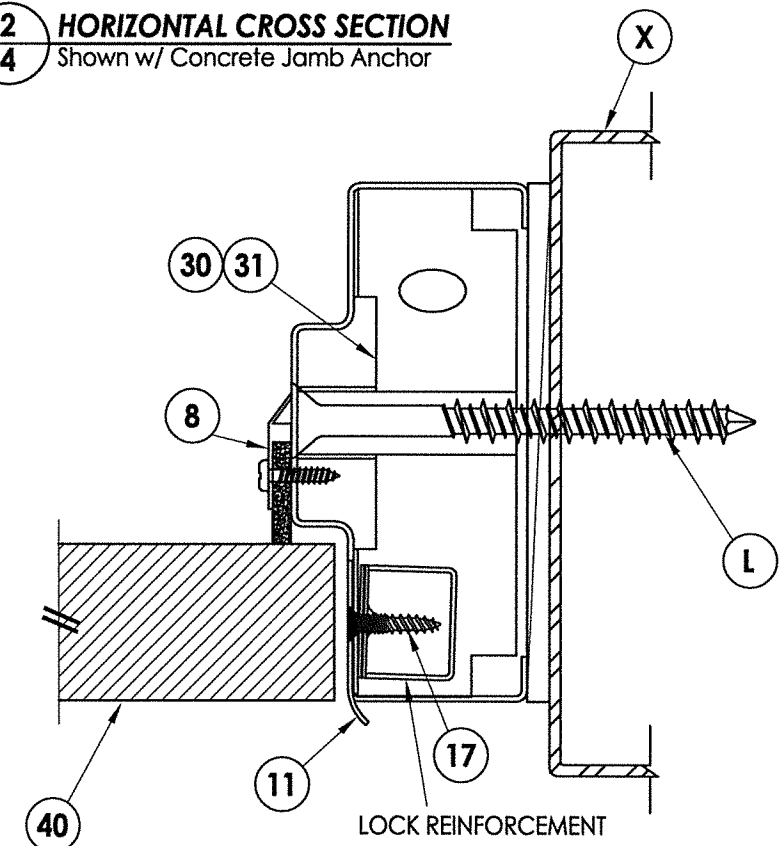

4 HORIZONTAL CROSS SECTION
4 Shown w/ Steel Stud Anchor

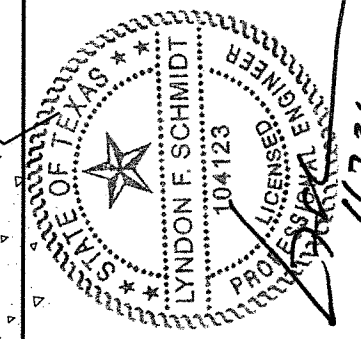

Documents Prepared By: Lyndon F. Schmidt, P.E.
TEXAS P.E. #104123

RW BUILDING CONSULTANTS, INC.
P.O. Box 230 Valrico FL 33595
Phone No.: 813.659.9197

TEXAS BOARD OF PROFESSIONAL ENGINEERS
CERTIFICATE OF REGISTRATION # F-11852

PRODUCT: VISION HOLLOW METAL

PART OR ASSEMBLY: HORIZONTAL CROSS SECTIONS

NO.	DATE	BY	REVISIONS
1	11/3/21	LFS	UPDATE TO 2018 IBC/IRC

DATE: 6/06/17
SCALE: N.T.S.
DWG. BY: JK
CHK. BY: LFS
DRAWING NO.: TX-4703
SHEET 4 OF 8

© 2017 R.W. BUILDING CONSULTANTS INC.

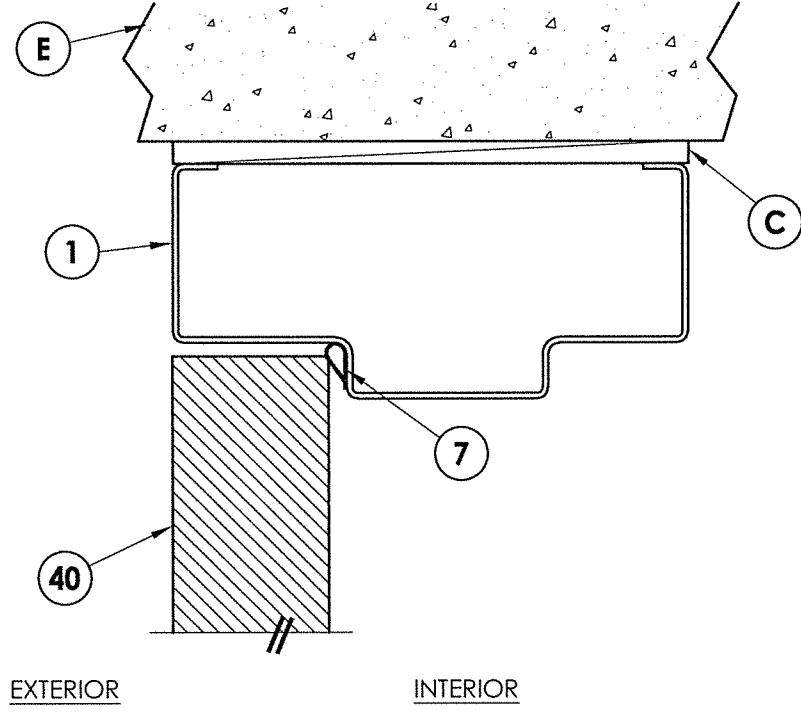

1
5 **VERTICAL CROSS SECTION**

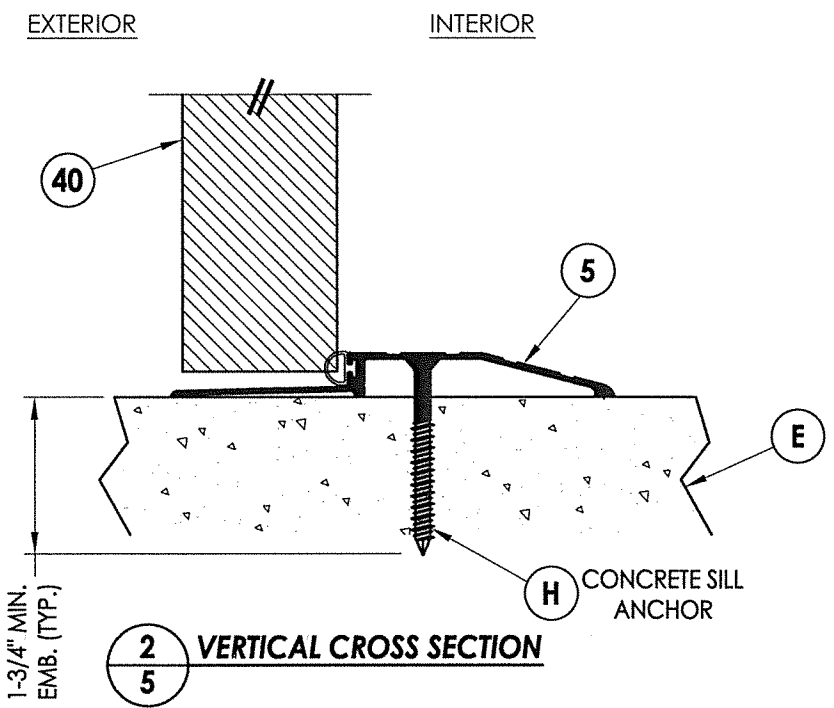

2
5 **VERTICAL CROSS SECTION**

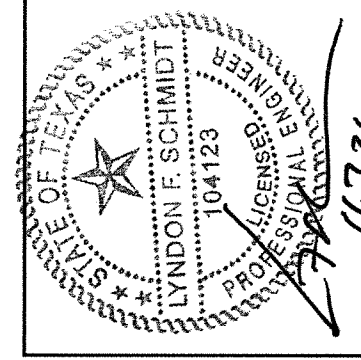

Documents Prepared By: Lyndon F. Schmidt, P.E.
TEXAS P.E. #104123

RW BUILDING CONSULTANTS, INC.
P.O. Box 230 Valrico FL 33595
Phone No.: 813.659.9197

TEXAS BOARD OF PROFESSIONAL ENGINEERS
CERTIFICATE OF REGISTRATION # F-11852

PRODUCT: VISION HOLLOW METAL

PART OR ASSEMBLY: VERTICAL CROSS SECTIONS

REVISIONS	
NO.	DATE
1	11/3/21
	UPDATE TO 2018 IBC/IRC
	LFS
	BY

DATE: 6/06/17

SCALE: N.T.S.

DWG. BY: JK

CHK. BY: LFS

DRAWING NO.: FL-19036.4

SHEET 5 OF 8

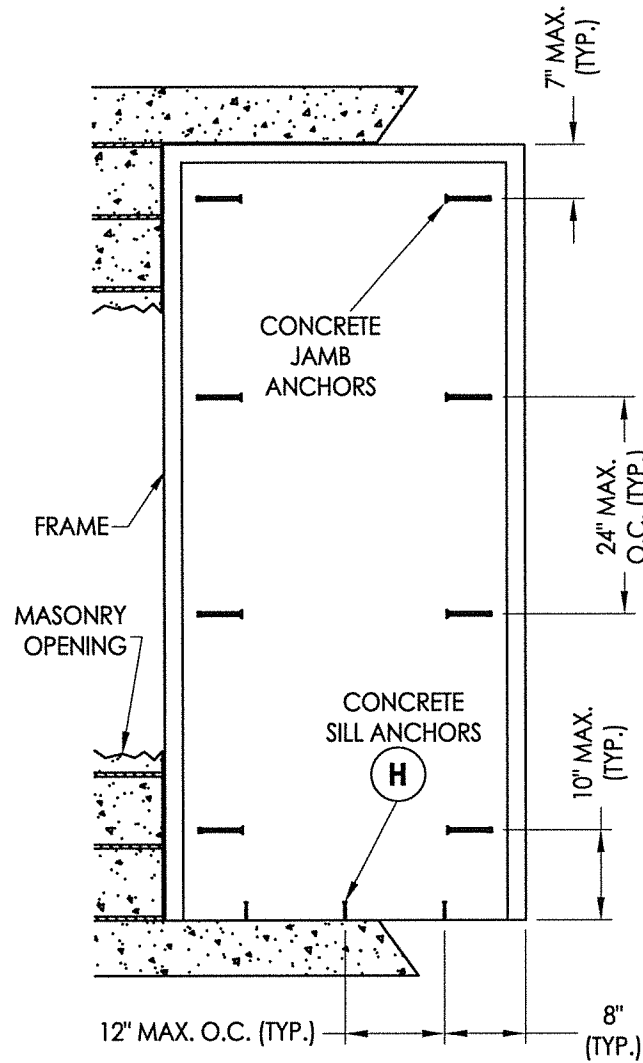

FRAME ANCHORING
Masonry Construction
Concrete Anchors

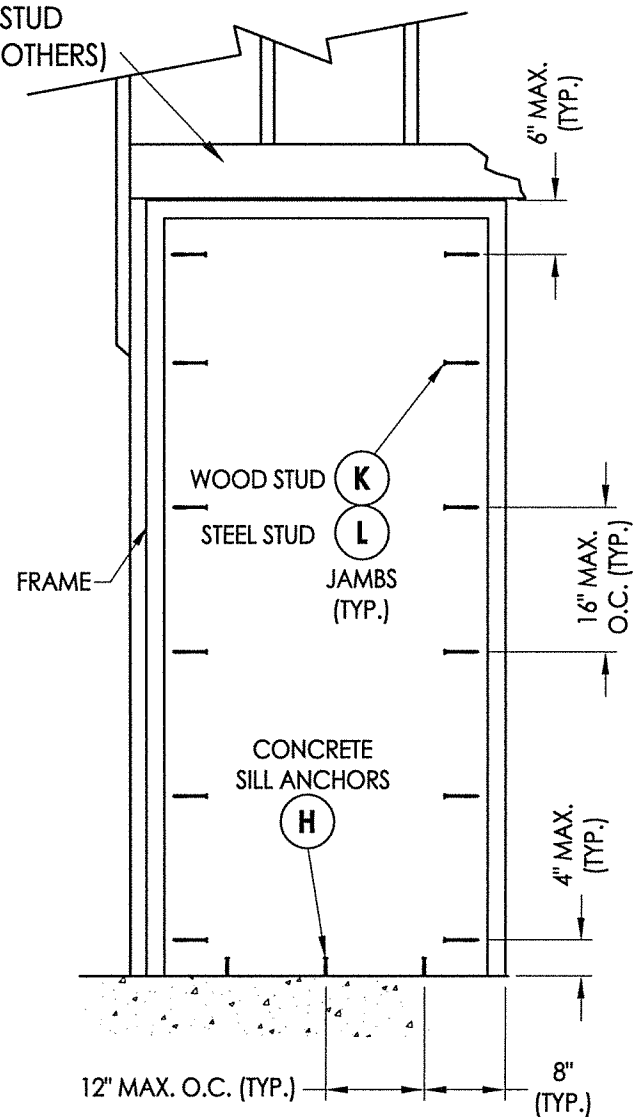

FRAME ANCHORING
Wood/Steel Stud

CONCRETE ANCHOR NOTES:

- Concrete screw locations at the corners may be adjusted to maintain a minimum 1" edge distance to mortar joints. If concrete screw locations noted as "MAX. O.C." must be adjusted to maintain the minimum edge distance to mortar joints, additional concrete screws may be required to ensure the maximum on center dimension is not exceeded.
- Concrete anchor table:

ANCHOR TYPE	ANCHOR LOCATION	ANCHOR SIZE	MANUFACTURER	MIN. EDGE DISTANCE	MIN. EMBEDMENT
CONCRETE ANCHOR SCREW	JAMBS	3/8"	LDT TAPCON® (ITW BUILDEX)	3"	1-1/2"
	SILL	1/4"	TAPCON® (ITW BUILDEX) ULTRACON+® (DeWALT)	2-1/2"	1-3/4"
CONCRETE SLEEVE ANCHOR	JAMBS	3/8"	DYNABOLT SLEEVE ANCHOR® (ITW REDHEAD)	2-1/4"	1-1/2"

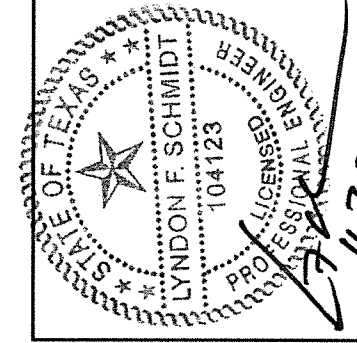

Documents Prepared By: Lyndon F. Schmidt, P.E.
TEXAS P.E. #104123

RW BUILDING CONSULTANTS, INC.
P.O. Box 230 Valrico FL 33595
Phone No.: 813.659.9197
TEXAS BOARD OF PROFESSIONAL ENGINEERS
CERTIFICATE OF REGISTRATION # F-11852

PRODUCT: VISION HOLLOW METAL
PART OR ASSEMBLY: FRAME ANCHORING

NO.	DATE	REVISIONS
1	11/3/21	UPDATE TO 2018 IBC/IRC
		LFS BY

DATE: 6/06/17
SCALE: N.T.S.
DWG. BY: JK
CHK. BY: LFS
DRAWING NO.: TX-4703
SHEET 6 OF 8

MASONRY WIRE ANCHOR LOCATIONS
(4 MIN. TOTAL PER JAMB)

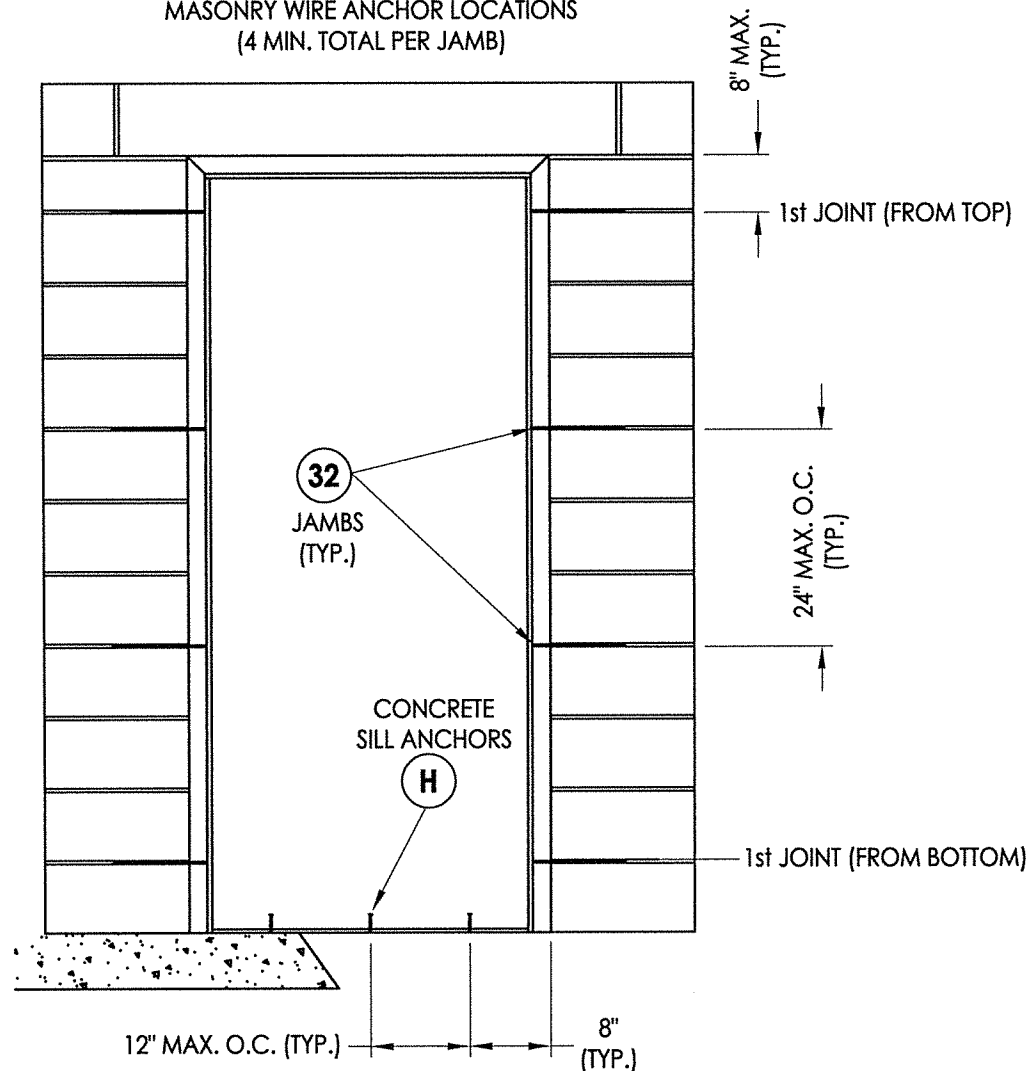

FRAME ANCHORING
Masonry Construction
Masonry Wire Anchors

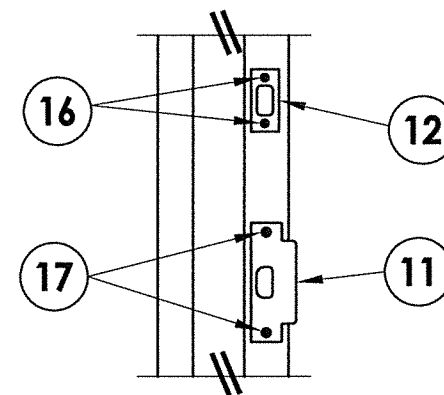

STRIKE DETAIL
Latch & Deadbolt

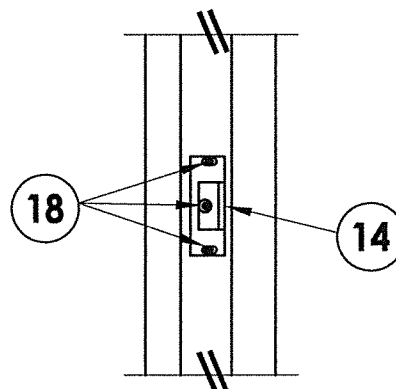

STRIKE DETAIL
Rim Exit Device

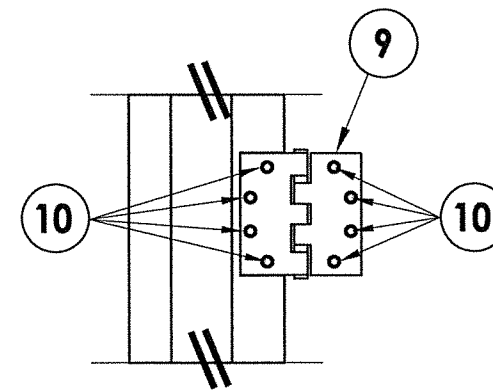

HINGE DETAIL

CONCRETE ANCHOR NOTES:

- Concrete screw locations at the corners may be adjusted to maintain a minimum 1" edge distance to mortar joints. If concrete screw locations noted as "MAX. O.C." must be adjusted to maintain the minimum edge distance to mortar joints, additional concrete screws may be required to ensure the maximum on center dimension is not exceeded.
- Concrete anchor table:

ANCHOR TYPE	ANCHOR LOCATION	ANCHOR SIZE	MANUFACTURER	MIN. EDGE DISTANCE	MIN. EMBEDMENT
CONCRETE ANCHOR SCREW	SILL	1/4"	TAPCON® (ITW BUILDEX) ULTRACON+® (DeWALT)	2-1/2"	1-3/4"

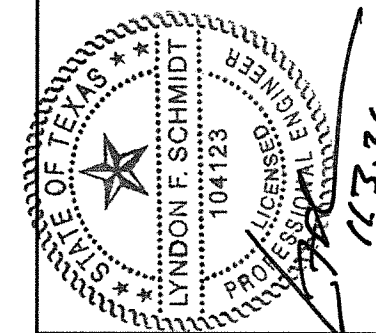

Documents Prepared By: Lyndon F. Schmidt, P.E.
TEXAS P.E. #104123

RW BUILDING CONSULTANTS, INC.
P.O. Box 230 Valrico FL 33595
Phone No.: 813.659.9197
TEXAS BOARD OF PROFESSIONAL ENGINEERS
CERTIFICATE OF REGISTRATION # F-11852

PRODUCT: VISION HOLLOW METAL

PART OR ASSEMBLY: FRAME ANCHORING

NO.	DATE	BY	REVISIONS
1	11/3/21	LFS	UPDATE TO 2018 IBC/IRC

DATE: 6/06/17

SCALE: N.T.S.

DWG. BY: JK

CHK. BY: LFS

DRAWING NO.: TX-4703

SHEET 7 OF 8

BILL OF MATERIALS		
ITEM #	DESCRIPTION	MATERIAL
B	2X STUD FRAMING (G>= 0.42)	WOOD
C	1/4" MAX. SHIM SPACE	-
E	MASONRY - 3,000 PSI MIN. CONCRETE CONFORMING TO ACI 301 OR HOLLOW BLOCK (GROUT FILLED) CONFORMING TO ASTM C90	CONCRETE
H	1/4" X 1-3/4" PFH CONCRETE SCREW (SEE CONCRETE ANCHOR TABLE)	STEEL
J	3/8" X 5" PFH DYNABOLT SLEEVE ANCHOR (SEE CONCRETE ANCHOR TABLE)	STEEL
K	3/8" X 5" FH LAG SCREW (2-1/8" MIN. EMBEDMENT)	STEEL
L	3/8" Ø SMS (MUST PENETRATE MIN. 3 THREADS THROUGH STEEL STUD)	STEEL
M	3/8" X 5" LDT TAPCON CONCRETE SCREW (SEE CONCRETE ANCHOR TABLE)	STEEL
X	STEEL STUD (0.125" MIN. THK, Fu = 50 ksi, Fy = 33 ksi)	STEEL
1	HOLLOW METAL FRAME	-
5	OUTSWING BUMP THRESHOLD	ALUM
7	WEATHERSTRIP (HAGER 736 PRESS-ON)	-
8	FRAME WEATHERSTRIP (HAGER 875S)	-
9	HINGE 4.5" X 4.5"	STEEL
10	#12-24 X 1/2" FH MACHINE SCREW	STEEL
11	LATCH STRIKE PLATE	STEEL
12	DEADBOLT STRIKE PLATE	STEEL
13	VERTICAL ROD STRIKE PLATE	STEEL
14	RIM EXIT DEVICE STRIKE	STEEL
16	#8 X 3/4" FH SCREWS	STEEL
17	#12 X 1" FH SCREWS	STEEL
18	#12 X 1-1/8" PH SMS	STEEL
20	HINGE REINFORCEMENT (10 GA.)	STEEL
30	EMA PIPE ANCHOR (18 GA)	STEEL
31	EMA BUTTERFLY ANCHOR (18 GA)	STEEL
32	MASONRY WIRE ANCHOR	STEEL
40	STEEL DOOR PANEL (7'-0" DOOR)	STEEL

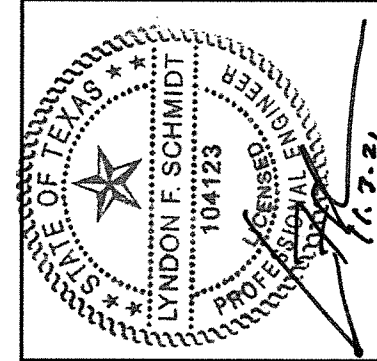
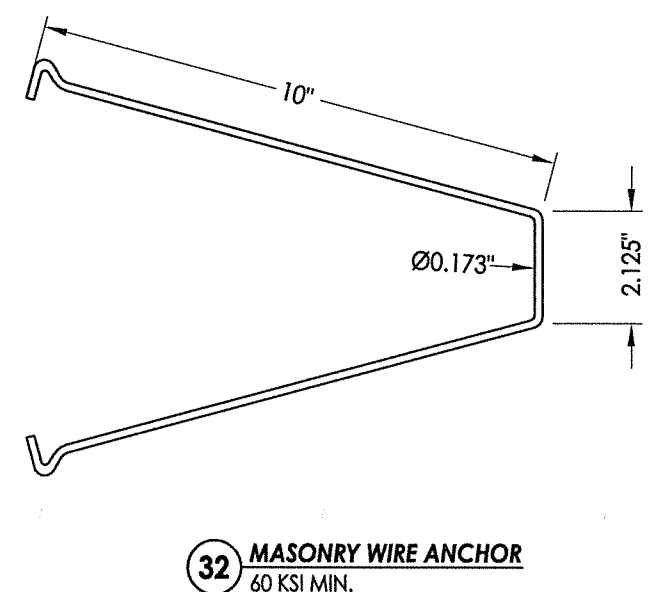
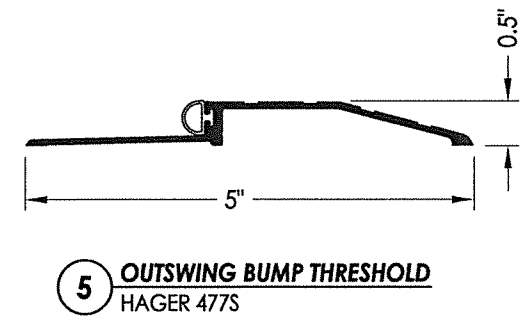
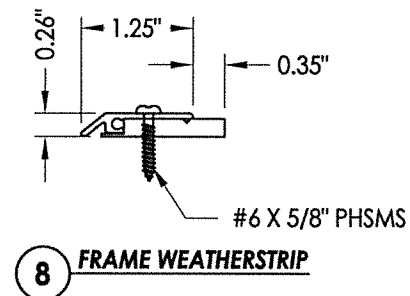
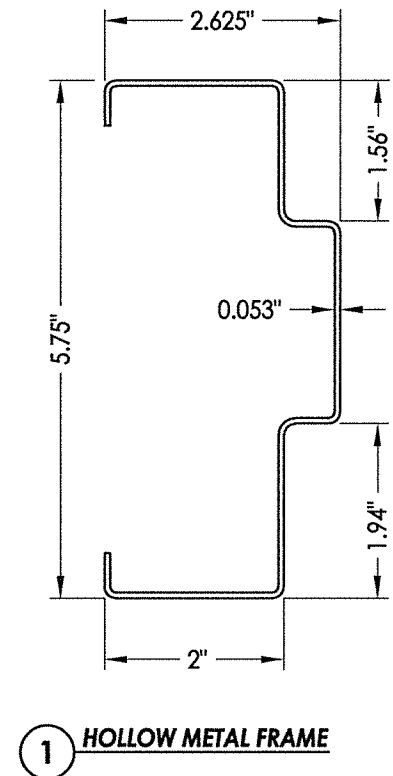

Documents Prepared By: Lyndon F. Schmidt, P.E.
TEXAS P.E. #104123

R.W. BUILDING CONSULTANTS, INC.
P.O. Box 230 Valrico FL 33595
Phone No.: 813.659.9197

TEXAS BOARD OF PROFESSIONAL ENGINEERS
CERTIFICATE OF REGISTRATION # F-11852

PRODUCT:	VISION HOLLOW METAL
PART OR ASSEMBLY:	BILL OF MATERIALS & COMPONENTS
DATE:	6/06/17
SCALE:	N.T.S.
DWG. BY:	JK
CHK. BY:	LFS
DRAWING NO.:	TX-4703
SHEET	8 OF 8

NO.	DATE	REVISIONS
1	11/3/21	UPDATE TO 2018 IBC/IRC
LFS	BY	