

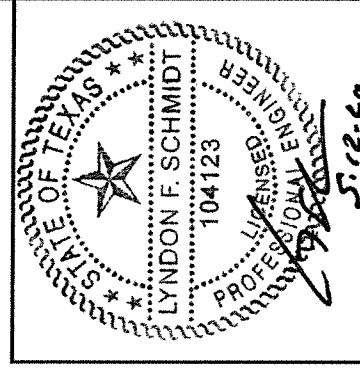

R:\Clients\Therma Tru PERMANENT\B - Texas Dept of Ins\TDI - DR 807 - 6'8 and 8'0 Minute Fire Doors (Book, Hybrid and UI) (X Inswing-Outswing) (4-28-16)\C - Drawings\TX-4608.9.10.dwg, 2.3

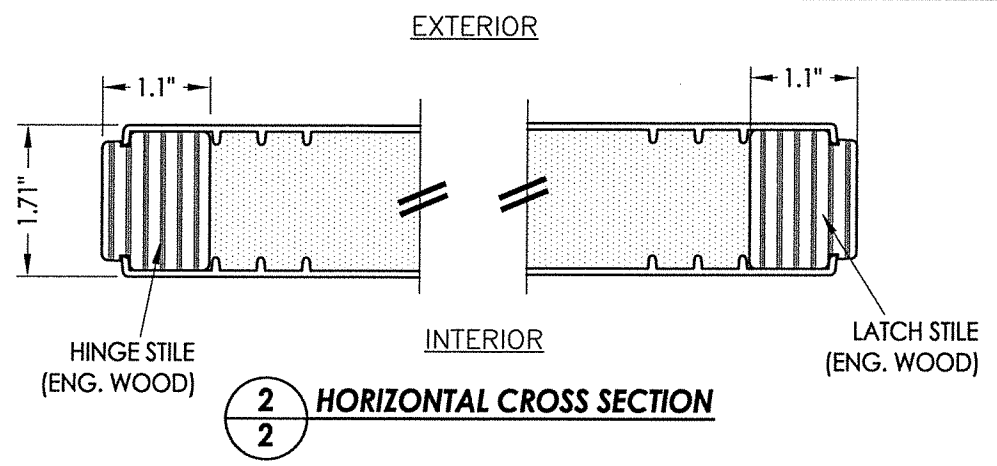
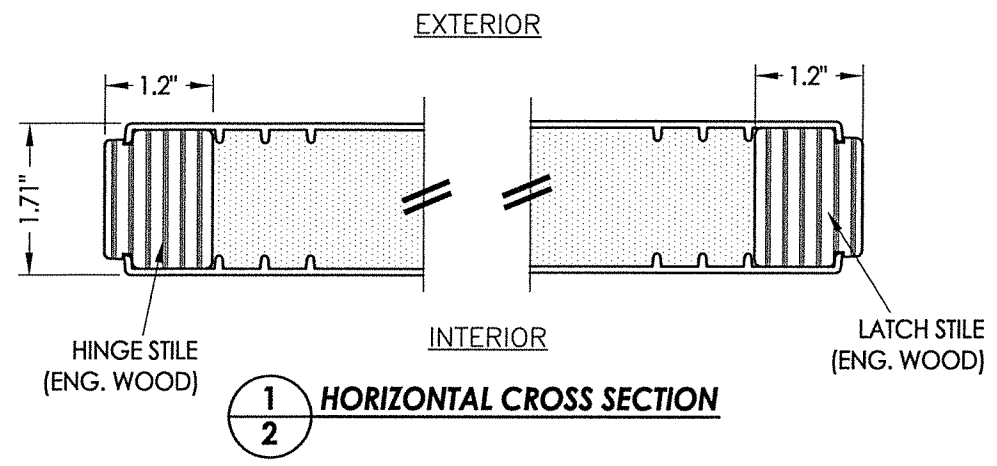

Documents Prepared By: Lyndon F. Schmidt, P.E.  
TEXAS P.E. #104123

**RW** BUILDING CONSULTANTS, INC.  
P.O. Box 230 Valrico FL, 33595  
Phone No.: 813.659.9197

TEXAS BOARD OF PROFESSIONAL ENGINEERS  
CERTIFICATE OF REGISTRATION # F-11852

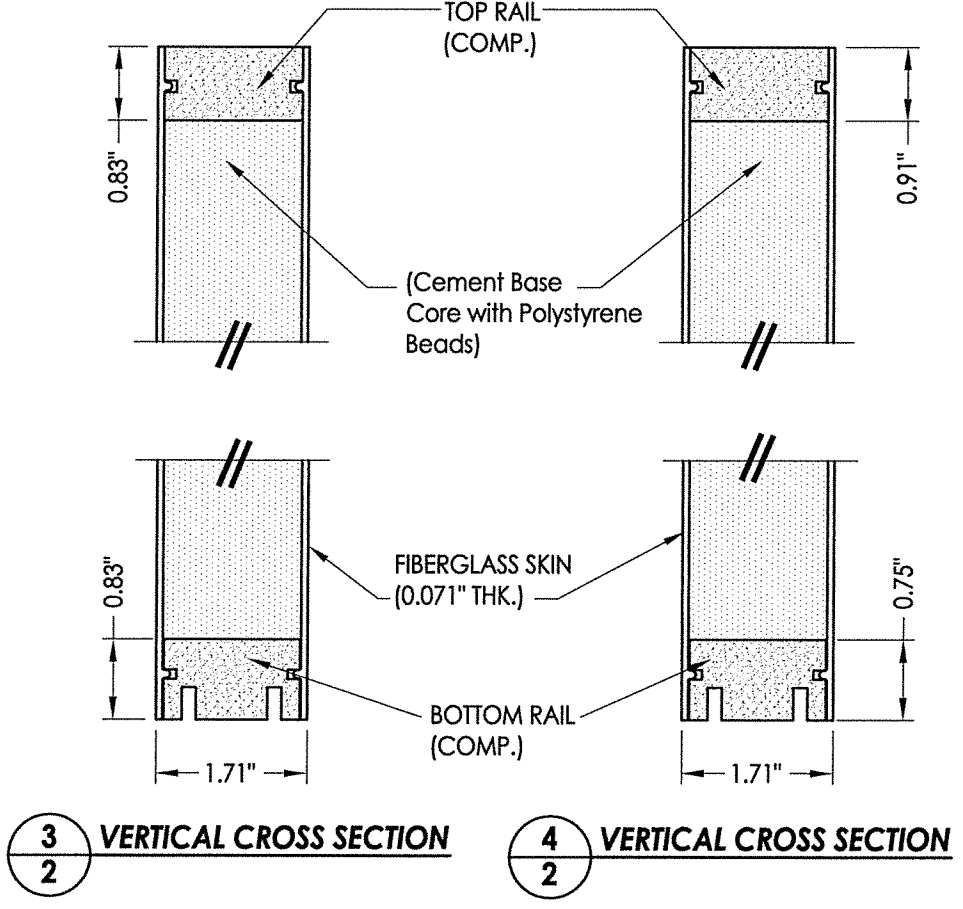
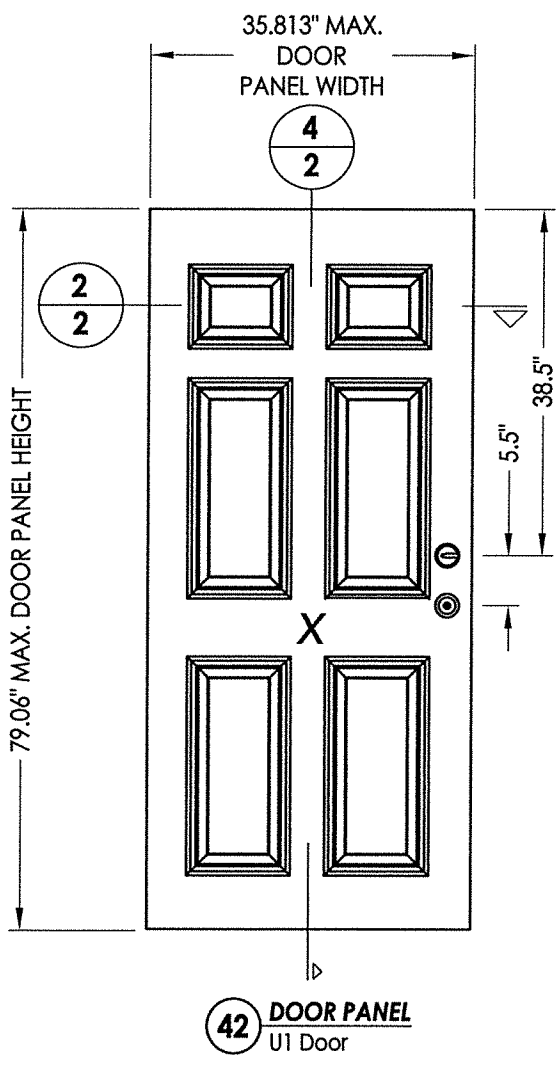
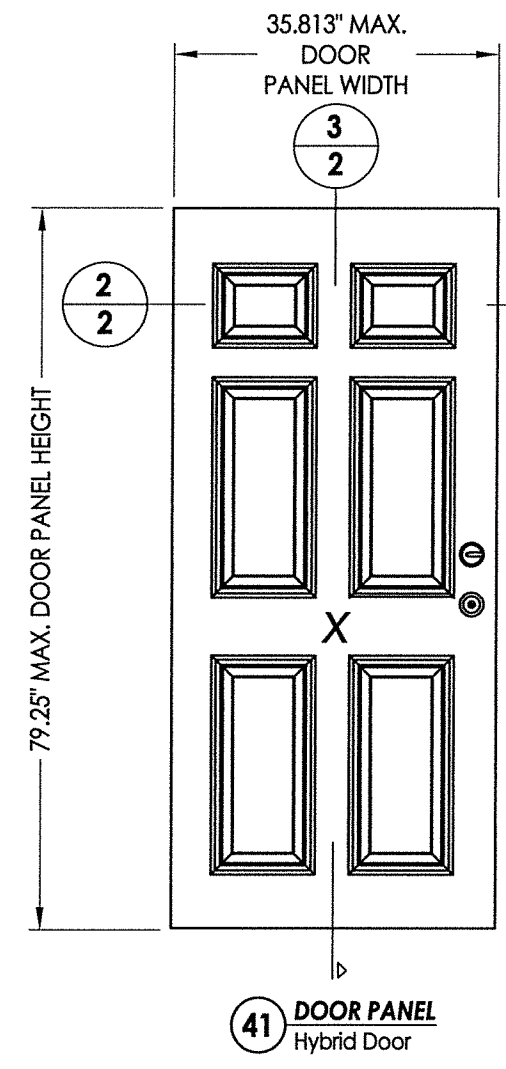
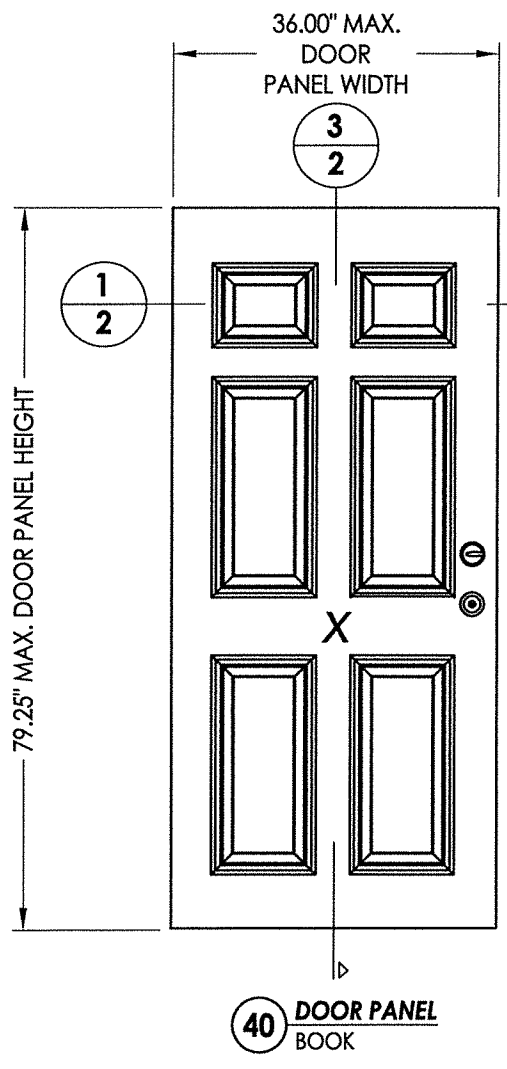

|                                      |         |
|--------------------------------------|---------|
| PRODUCT: FIBERGLASS DOOR             |         |
| PART OR ASSEMBLY: DOOR PANEL DETAILS |         |
| NO.                                  | DATE    |
| 1                                    | 5/12/20 |
| UPDATE TO 2018 IBC/IRC CODE          |         |
| LFS                                  | BY      |
| REVISIONS                            |         |
| DATE: 4/25/16                        |         |
| SCALE: N.T.S.                        |         |
| DWG. BY: JK                          |         |
| CHK. BY: LFS                         |         |
| DRAWING NO.: TX-4610                 |         |
| SHEET 2 OF 6                         |         |

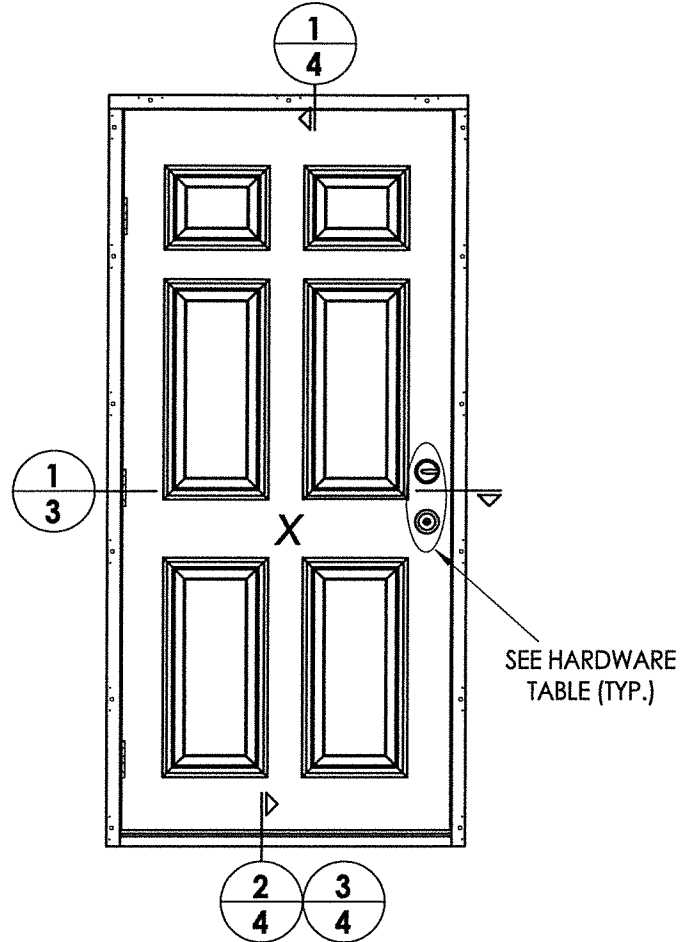

SEE HARDWARE TABLE (TYP.)

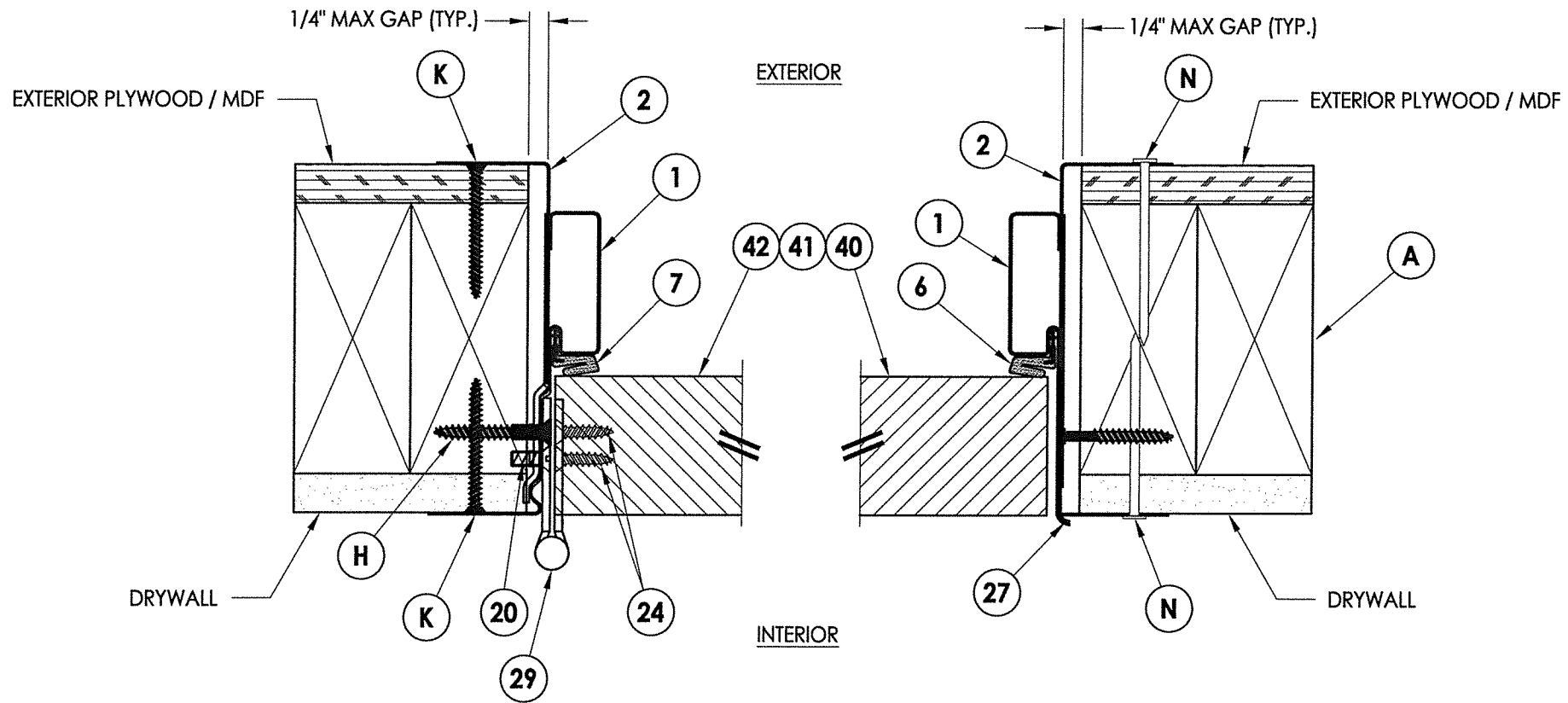

**1 HORIZONTAL CROSS SECTION**  
**3** Inswing shown (Outswing similar)

| HARDWARE TABLE |                                  |
|----------------|----------------------------------|
| MANUFACTURER   | MODEL                            |
| KWIKSET        | KNOB: SIGNATURE SERIES           |
|                | DEADBOLT: SIGNATURE SERIES (980) |
| SCHLAGE        | KNOB: "F" SERIES                 |
|                | DEADBOLT: "B" SERIES (B60)       |

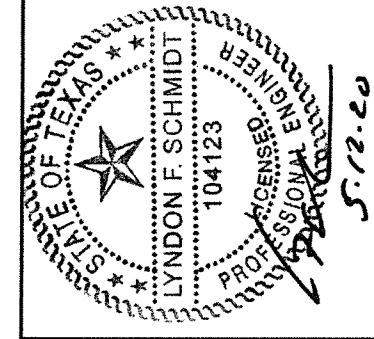

Documents Prepared By: Lyndon F. Schmidt, P.E.  
 TEXAS P.E. #104123

**RW** BUILDING CONSULTANTS, INC.  
 P.O. Box 230 Valrico FL, 33595  
 Phone No.: 813.659.9197  
 TEXAS BOARD OF PROFESSIONAL ENGINEERS  
 CERTIFICATE OF REGISTRATION # F-11852

|                   |                           |
|-------------------|---------------------------|
| PRODUCT:          | FIBERGLASS DOOR           |
| PART OR ASSEMBLY: | HORIZONTAL CROSS SECTIONS |
| DATE:             | 4/25/16                   |
| SCALE:            | N.T.S.                    |
| DWG. BY:          | JK                        |
| CHK. BY:          | LFS                       |
| DRAWING NO.:      | TX-4610                   |
| SHEET             | 3 OF 6                    |

R:\Clients\Therma Iru.Permanent B - Texas Dept of Ins\TDI - DB-807 - 6.8 and 8.0.20 Minute Fire Doors (Book Hybrid and U.I.)\X Inswing-Outswing) (4-28-16)\C - Drawings\TX-4608.9.10.dwg.4.3

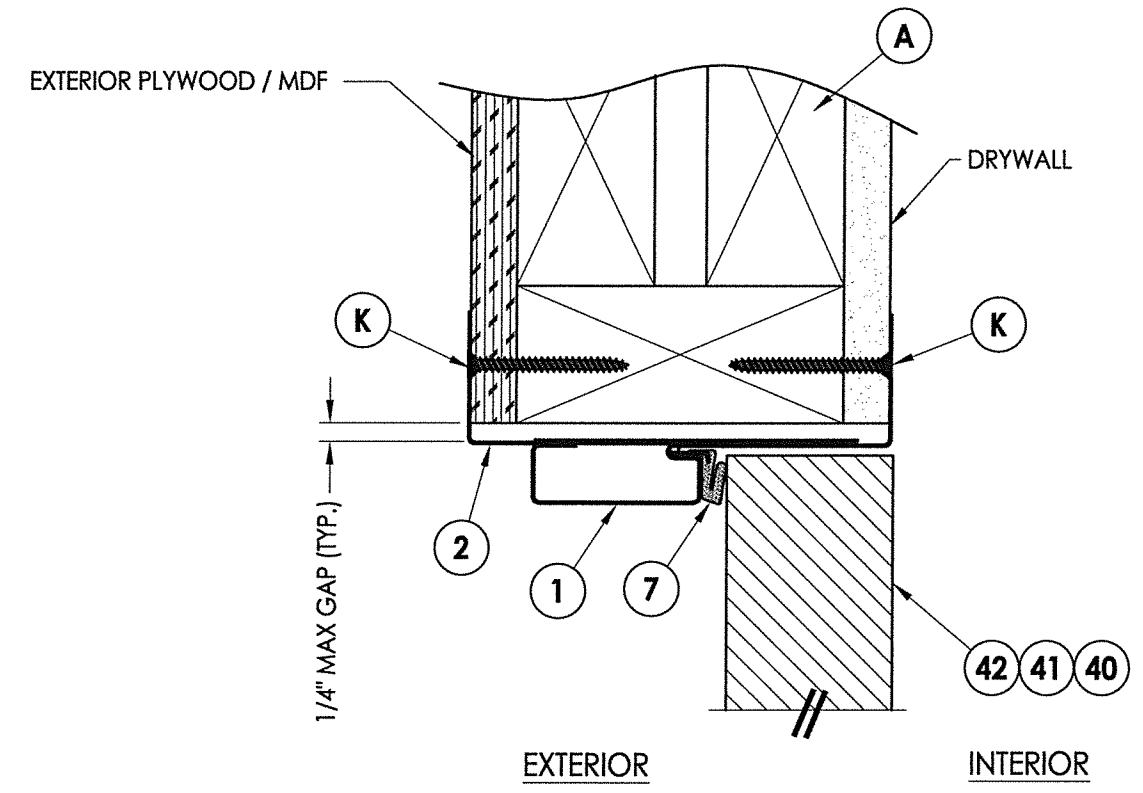

**1 VERTICAL CROSS SECTION**  
**4** Inswing shown (Outswing similar)

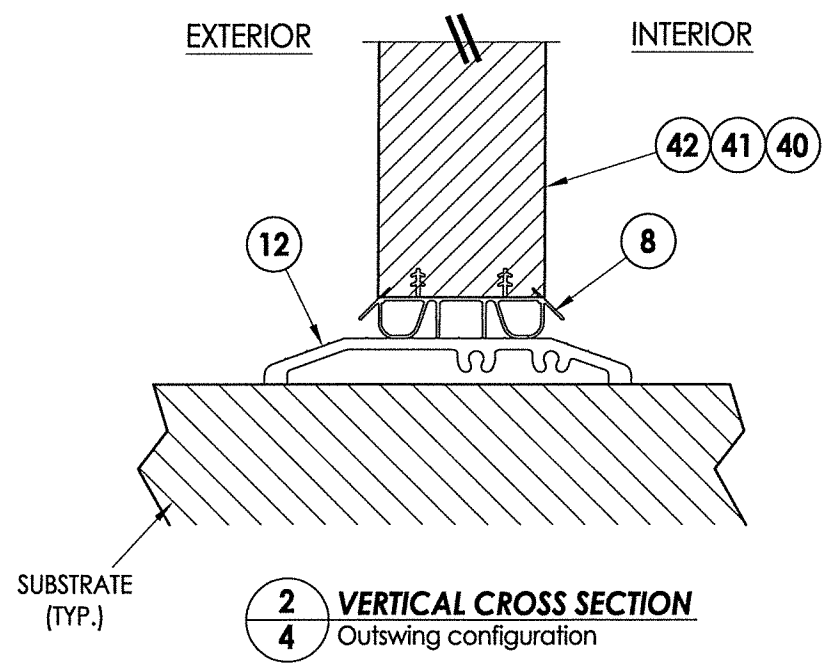

**2 VERTICAL CROSS SECTION**  
**4** Outswing configuration

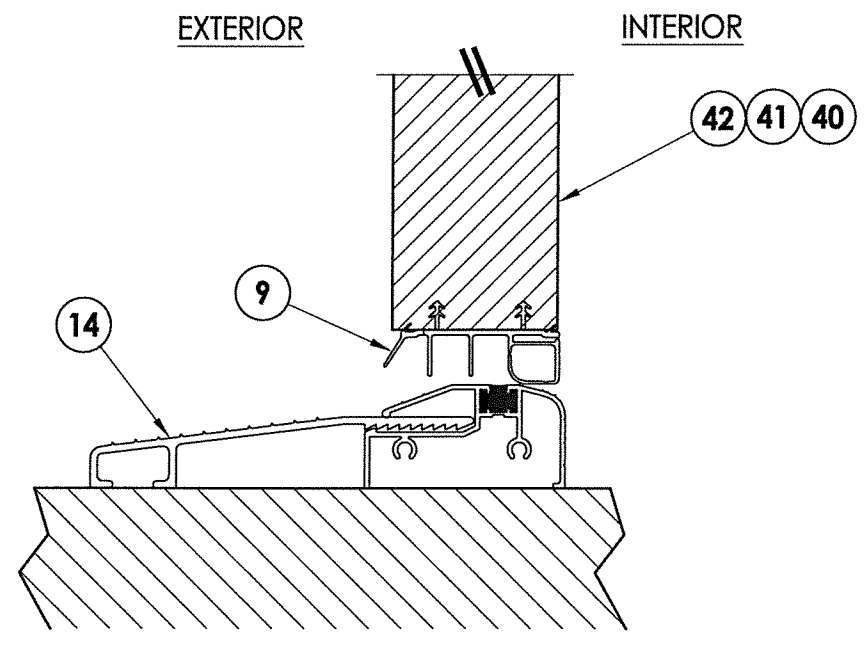

**3 VERTICAL CROSS SECTION**  
**4** Inswing configuration

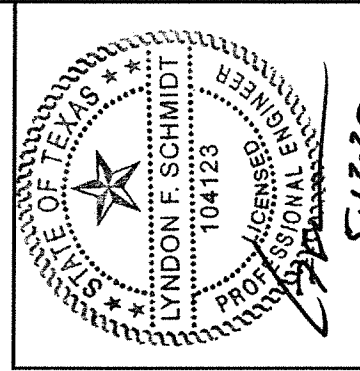

Documents Prepared By: Lyndon F. Schmidt, P.E.  
 TEXAS P.E. #104123

**RW** BUILDING CONSULTANTS, INC.  
 P.O. Box 230 Valrico FL 33595  
 Phone No.: 813.659.9197

TEXAS BOARD OF PROFESSIONAL ENGINEERS  
 CERTIFICATE OF REGISTRATION # F-11852

PRODUCT: FIBERGLASS DOOR

PART OR ASSEMBLY: VERTICAL CROSS SECTIONS

| NO. | DATE    | REVISIONS                   | BY  |
|-----|---------|-----------------------------|-----|
| 1   | 5/12/20 | UPDATE TO 2018 IBC/IRC CODE | LFS |

DATE: 4/25/16  
 SCALE: N.T.S.  
 DWG. BY: JK  
 CHK. BY: LFS  
 DRAWING NO.: TX-4610  
 SHEET 4 OF 6

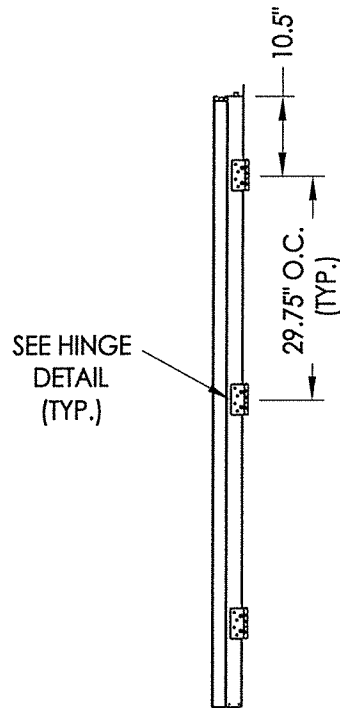

**HINGE JAMB**

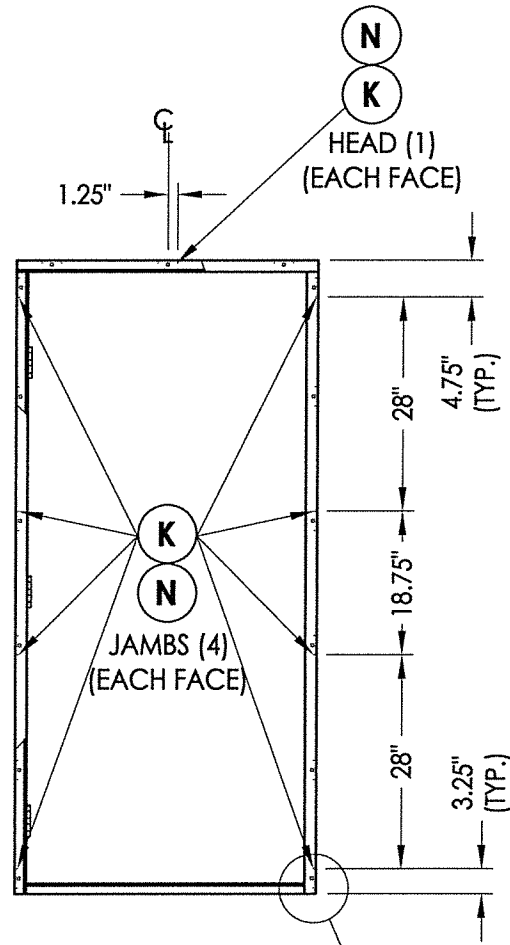

**FRAME ANCHORING**

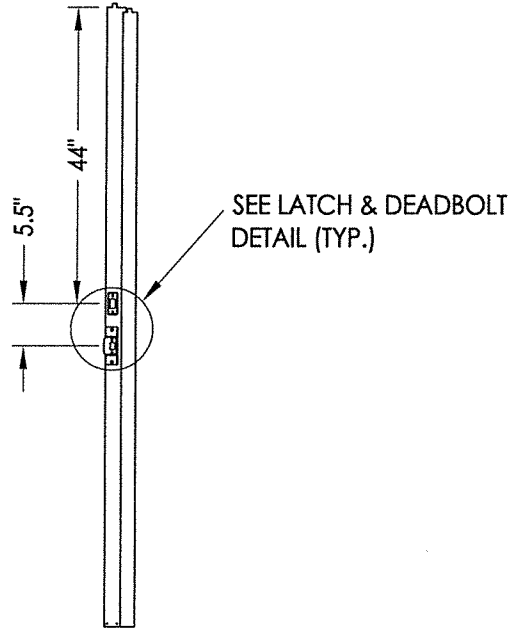

**STRIKE JAMB**

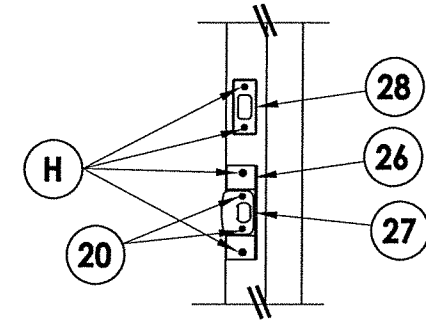
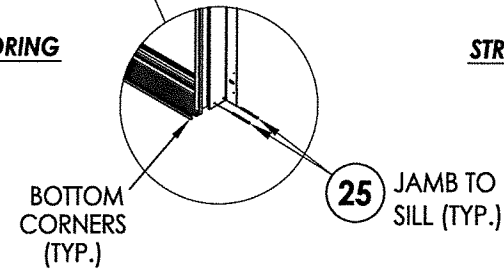

**LATCH & DEADBOLT DETAIL**

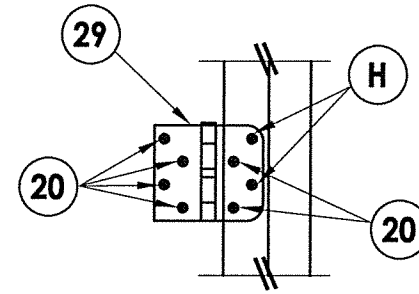

**HINGE DETAIL**

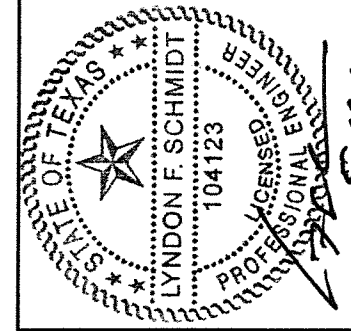

Documents Prepared By: Lyndon F. Schmidt, P.E.  
TEXAS P.E. #104123

**RW** BUILDING CONSULTANTS, INC.  
P.O. Box 230 Valrico FL 33595  
Phone No.: 813.659.9197

TEXAS BOARD OF PROFESSIONAL ENGINEERS  
CERTIFICATE OF REGISTRATION # F-11852

|                   |                        |
|-------------------|------------------------|
| PRODUCT:          | FIBERGLASS DOOR        |
| PART OR ASSEMBLY: | BUCK & FRAME ANCHORING |

| NO. | DATE    | DESCRIPTION                 | BY  |
|-----|---------|-----------------------------|-----|
| 1   | 5/12/20 | UPDATE TO 2018 IBC/IRC CODE | LFS |

|              |         |
|--------------|---------|
| DATE:        | 4/25/16 |
| SCALE:       | N.T.S.  |
| DWG. BY:     | JK      |
| CHK. BY:     | LFS     |
| DRAWING NO.: | TX-4610 |
| SHEET        | 5 OF 6  |

**BILL OF MATERIALS**

| ITEM # | DESCRIPTION                                     | MATERIAL |
|--------|---|----------|
| A      | 2X FRAMING (SG >= 0.42)                         | WOOD     |
| H      | #10 X 1-1/2" PFH WOOD SCREW                     | STEEL    |
| K      | #8 X 2" PFH WOOD SCREW (1-3/8" MIN. EMBEDMENT)  | STEEL    |
| N      | 8d X 2-1/2" COMMON NAIL (1-7/8" MIN. EMBEDMENT) | STEEL    |
| 1      | FRAME   | STEEL    |
| 2      | FRAME CLOSER                                    | STEEL    |
| 6      | WEATHERSTRIP (Medium Reach)                     | FOAM     |
| 7      | WEATHERSTRIP (Long Reach)                       | FOAM     |
| 8      | SWEEP   | VINYL    |
| 9      | SWEEP   | VINYL    |
| 12     | ADA THRESHOLD                                   | ALUM     |
| 14     | INSWING THRESHOLD                               | ALUM     |
| 20     | #10 x 1/2" THREAD CUTTING MACHINE SCREW         | STEEL    |
| 24     | #10 x 1" PFH WOOD SCREW                         | STEEL    |
| 25     | #8 x 2-1/2" PFH WOOD SCREW                      | STEEL    |
| 26     | LATCH ADAPTOR                                   | STEEL    |
| 27     | LATCH STRIKE PLATE                              | STEEL    |
| 28     | DEADBOLT STRIKE PLATE                           | STEEL    |
| 29     | 4" X 4" HINGE                                   | STEEL    |
| 40     | DOOR PANEL (BOOK)                               | -        |
| 41     | DOOR PANEL (HYBRID)                             | -        |
| 42     | DOOR PANEL (U1)                                 | -        |

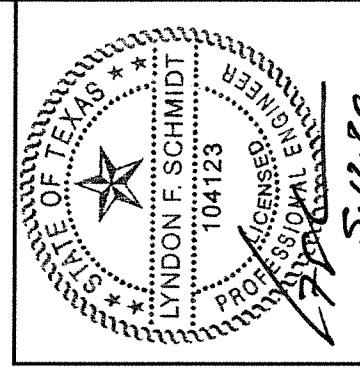
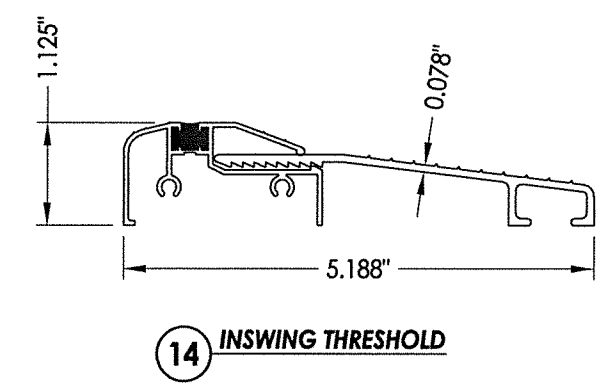
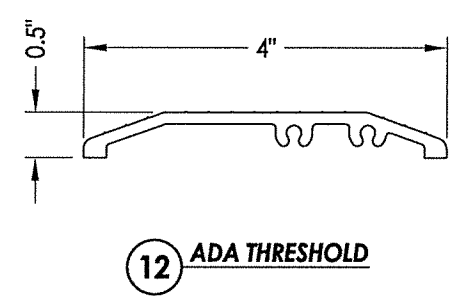
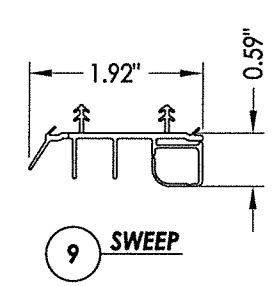
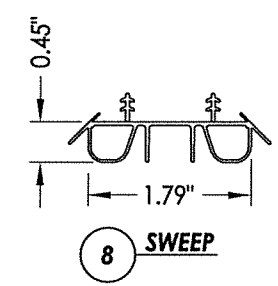
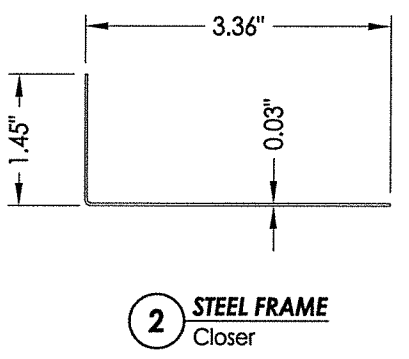
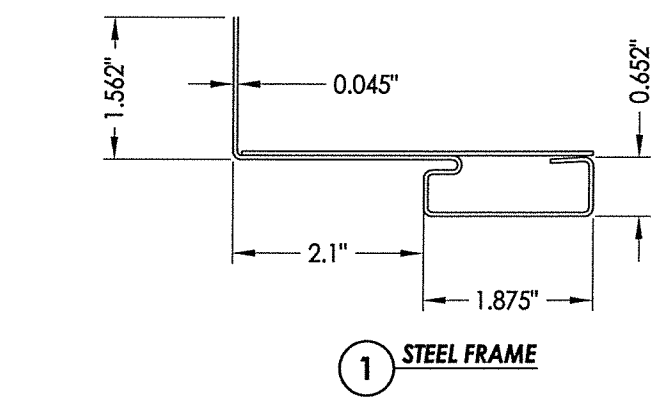

Documents Prepared By: Lyndon F. Schmidt, P.E.  
TEXAS P.E. #104123

**R.W.** BUILDING CONSULTANTS, INC.  
P.O. Box 230 Valrico FL 33595  
Phone No.: 813.659.9197

TEXAS BOARD OF PROFESSIONAL ENGINEERS  
CERTIFICATE OF REGISTRATION # F-11852

PRODUCT: FIBERGLASS DOOR

PART OR ASSEMBLY: BILL OF MATERIALS AND COMPONENTS

| NO. | DATE    | DESCRIPTION                 | LFS | BY |
|-----|---------|-----------------------------|-----|----|
| 1   | 5/12/20 | UPDATE TO 2018 IBC/IRC CODE |     |    |

REVISIONS

DATE: 4/25/16

SCALE: N.T.S.

DWG. BY: JK

CHK. BY: LFS

DRAWING NO.: TX-4610

SHEET 6 OF 6