

REVISIONS			
REV	DESCRIPTION	DATE	APPROVED
A	UPDATED PER NEW CODES	10/04/2021	R.L.

NOTES:

1. THE PRODUCT SHOWN HEREIN IS DESIGNED AND MANUFACTURED TO COMPLY WITH REQUIREMENTS OF THE 2018 IBC AND 2018 IRC.
2. WOOD FRAMING AND MASONRY OPENING TO BE DESIGNED AND ANCHORED TO PROPERLY TRANSFER ALL LOADS TO STRUCTURE. FRAMING AND MASONRY OPENING IS THE RESPONSIBILITY OF THE ARCHITECT OR ENGINEER OF RECORD.
3. 1X BUCK OVER MASONRY/CONCRETE IS OPTIONAL.
4. WHERE SHIM OR BUCK THICKNESS IS LESS THAN 1-1/2" WINDOW UNITS MUST BE ANCHORED THROUGH THE FRAME IN ACCORDANCE WITH MANUFACTURER'S PUBLISHED INSTALLATION INSTRUCTIONS. ANCHORS SHALL BE SECURELY FASTENED DIRECTLY INTO MASONRY, CONCRETE OR OTHER STRUCTURAL SUBSTRATE MATERIAL.
5. WHERE WOOD BUCK THICKNESS IS 1-1/2" OR GREATER, BUCK SHALL BE SECURELY FASTENED TO MASONRY, CONCRETE OR OTHER STRUCTURAL SUBSTRATE. WINDOW UNITS MAY BE ANCHORED THROUGH FRAME TO SECURED WOOD BUCK IN ACCORDANCE WITH MANUFACTURER'S PUBLISHED INSTALLATION INSTRUCTIONS.
6. WHERE 1X BUCK IS NOT USED DISSIMILAR MATERIALS MUST BE SEPARATED WITH APPROVED COATING OR MEMBRANE. SELECTION OF COATING OR MEMBRANE IS THE RESPONSIBILITY OF THE ARCHITECT OR ENGINEER OF RECORD.
7. BUCKS SHALL EXTEND BEYOND WINDOW INTERIOR FACE SO THAT FULL FRAME SUPPORT IS PROVIDED.
8. FOR FIN INSTALLATION SHIM AS NEEDED. FOR FRAME INSTALLATION SHIM AS REQUIRED AT EACH ANCHOR LOCATION WITH LOAD BEARING SHIM. SHIM WHERE SPACE OF 1/16" OR GREATER OCCURS. MAXIMUM ALLOWABLE SHIM STACK TO BE 1/4".
9. SHIMS SHALL BE LOCATED, APPLIED AND MADE FROM MATERIALS AND THICKNESS CAPABLE OF SUSTAINING APPLICABLE LOADS.
10. WIND LOAD DURATION FACTOR Cd=1.6 WAS USED FOR WOOD ANCHOR CALCULATIONS.
11. FRAME MATERIAL: EXTRUDED RIGID PVC.
12. UNITS MUST BE GLAZED PER ASTM E1300 WITH SAFETY GLAZING.
13. APPROVED IMPACT PROTECTIVE SYSTEM IS REQUIRED FOR THIS PRODUCT IN WIND BORNE DEBRIS REGIONS.
14. FOR ANCHORING THROUGH FRAME INTO WOOD FRAMING OR 2X BUCK USE #10 WOOD SCREWS WITH SUFFICIENT LENGTH TO ACHIEVE A 1 1/4" MINIMUM EMBEDMENT INTO SUBSTRATE. LOCATE ANCHORS AS SHOWN IN ELEVATIONS AND INSTALLATION DETAILS.

15. FOR ANCHORING THROUGH FRAME INTO MASONRY/CONCRETE USE 1/4" TAPCONS WITH SUFFICIENT LENGTH TO ACHIEVE A 1 1/4" MINIMUM EMBEDMENT INTO SUBSTRATE WITH 2" MINIMUM EDGE DISTANCE. LOCATE ANCHORS AS SHOWN IN ELEVATIONS AND INSTALLATION DETAILS.
16. FOR ANCHORING THROUGH FRAME INTO METAL STRUCTURE USE #10 SMS OR SELF DRILLING SCREWS WITH SUFFICIENT LENGTH TO ACHIEVE 3 THREADS MINIMUM BEYOND STRUCTURE INTERIOR WALL. LOCATE ANCHORS AS SHOWN IN ELEVATIONS AND INSTALLATION DETAILS.
17. ALL FASTENERS TO BE CORROSION RESISTANT.
18. INSTALLATION ANCHORS SHALL BE INSTALLED IN ACCORDANCE WITH ANCHOR MANUFACTURER'S INSTALLATION INSTRUCTIONS AND ANCHORS SHALL NOT BE USED IN SUBSTRATES WITH STRENGTHS LESS THAN THE MINIMUM STRENGTH SPECIFIED BELOW:
 - A. WOOD: MINIMUM SPECIFIC GRAVITY OF G=0.42
 - B. CONCRETE: MINIMUM COMPRESSIVE STRENGTH OF 2,000 PSI.
 - C. MASONRY: HOLLOW/FILLED BLOCK PER ASTM C90 WITH f'm=2,000PSI MINIMUM.
 - D. METAL STRUCTURE: STEEL 18GA (.048") FY=33KSI/FU=52KSI OR ALUMINUM 6063-T5 FU=30KSI 1/8" THICK MINIMUM
19. APPROVED CONFIGURATIONS: X, XX, XXX.

SIGNED: 10/04/2021

TABLE OF CONTENTS	
SHEET NO.	DESCRIPTION
1	NOTES
2	ELEVATION
3 - 5	INSTALLATION DETAILS
6	HARDWARE COMPONENTS

NAN YA PLASTICS CORP. USA 8989 NORTH LOOP EAST HOUSTON, TX 77029		
SERIES JBL FIBERGLASS OUT-SWING FOLDING DOOR NON-IMPACT NOTES		
DRAWN: N.G.	DWG NO. 08-02883	REV A
SCALE NTS	DATE 02/24/16	SHEET 4 OF 6
L. ROBERTO LOMAS P.E. 1432 WOODFORD RD LEWISVILLE, NC 27023 434-688-0609 rllomas@lrlomaspe.com		



Luis R. Lomas P.E.
TX No.: 101889

REVISIONS			
REV	DESCRIPTION	DATE	APPROVED
A	UPDATED PER NEW CODES	10/04/2021	R.L.

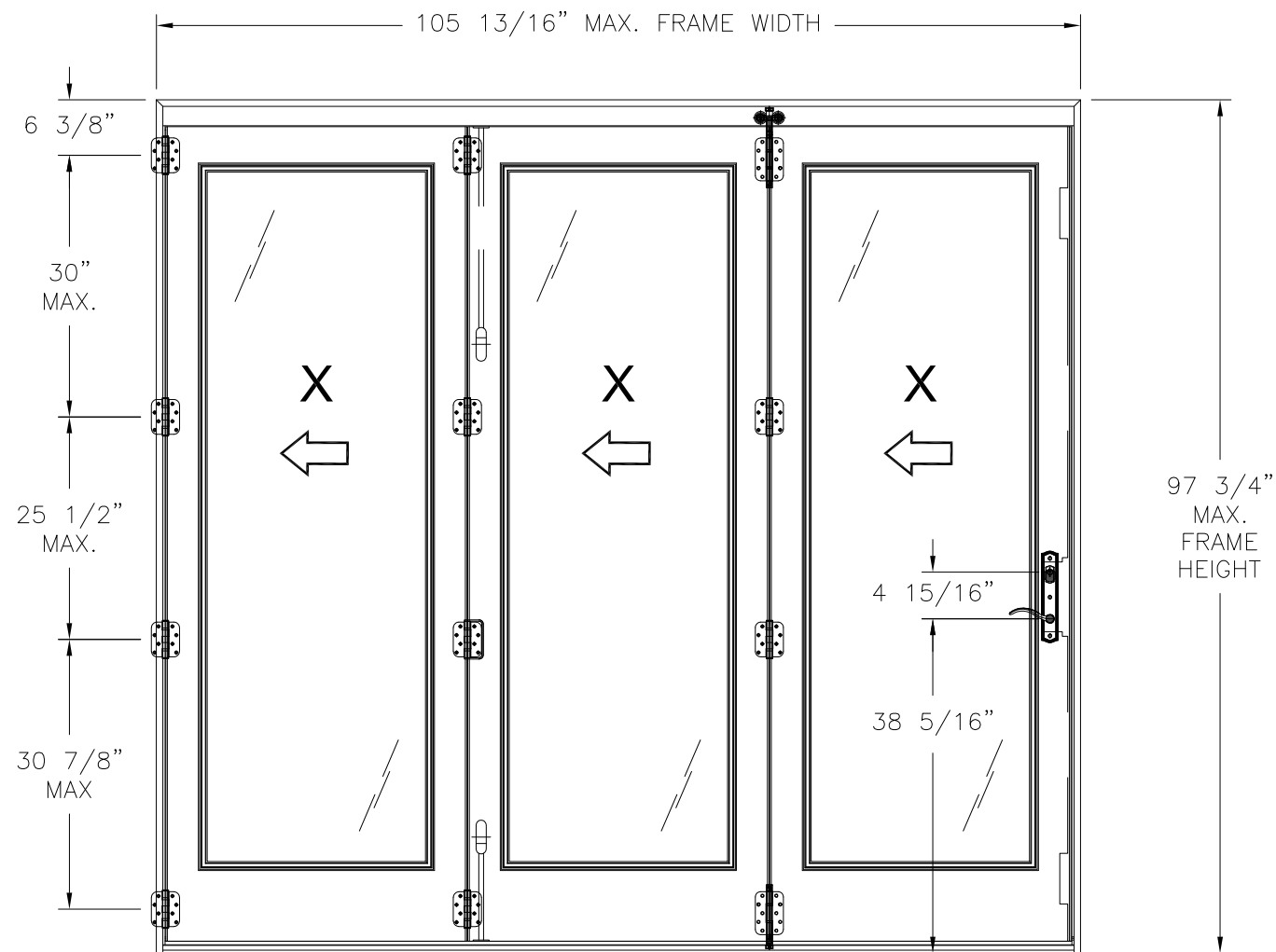

SERIES JBL FIBERGLASS OS FOLDING DOOR
EXTERIOR VIEW

DESIGN PRESSURE RATING	IMPACT RATING
±45.0PSF	NONE

NOTES:

1. MAXIMUM PANEL SIZE: 34 1/2" X 93 5/16"
2. MAXIMUM D.L.O.: 25" X 79"

HARDWARE SCHEDULE

A.	(4) HINGES 4" PER PANEL
B.	(1) HINGE WITH CARRIER AT HINGE STILE
C.	(1) MULTIPPOINT LOCK (SS930093) BY JAM YUAN ENTERPRISES WITH KEEPERS
D.	(1) 12" FLUSH BOLT BAR AT PANEL BOTTOM
F.	(1) 25" FLUSH BOLT BAR AT PANEL TOP

SIGNED: 10/04/2021

NAN YA PLASTICS CORP. USA

8989 NORTH LOOP EAST
HOUSTON, TX 77029

SERIES JBL FIBERGLASS OUT-SWING
FOLDING DOOR NON-IMPACT
ELEVATION

DRAWN: N.G.	DWG NO. 08-02883	REV A
SCALE NTS	DATE 02/24/16	SHEET 2 OF 6
L. ROBERTO LOMAS P.E. 1432 WOODFORD RD LEWISVILLE, NC 27023 434-688-0609 rllomas@lrlomaspe.com		



Luis R. Lomas P.E.
TX No.: 101889

REVISIONS			
REV	DESCRIPTION	DATE	APPROVED
A	UPDATED PER NEW CODES	10/04/2021	R.L.

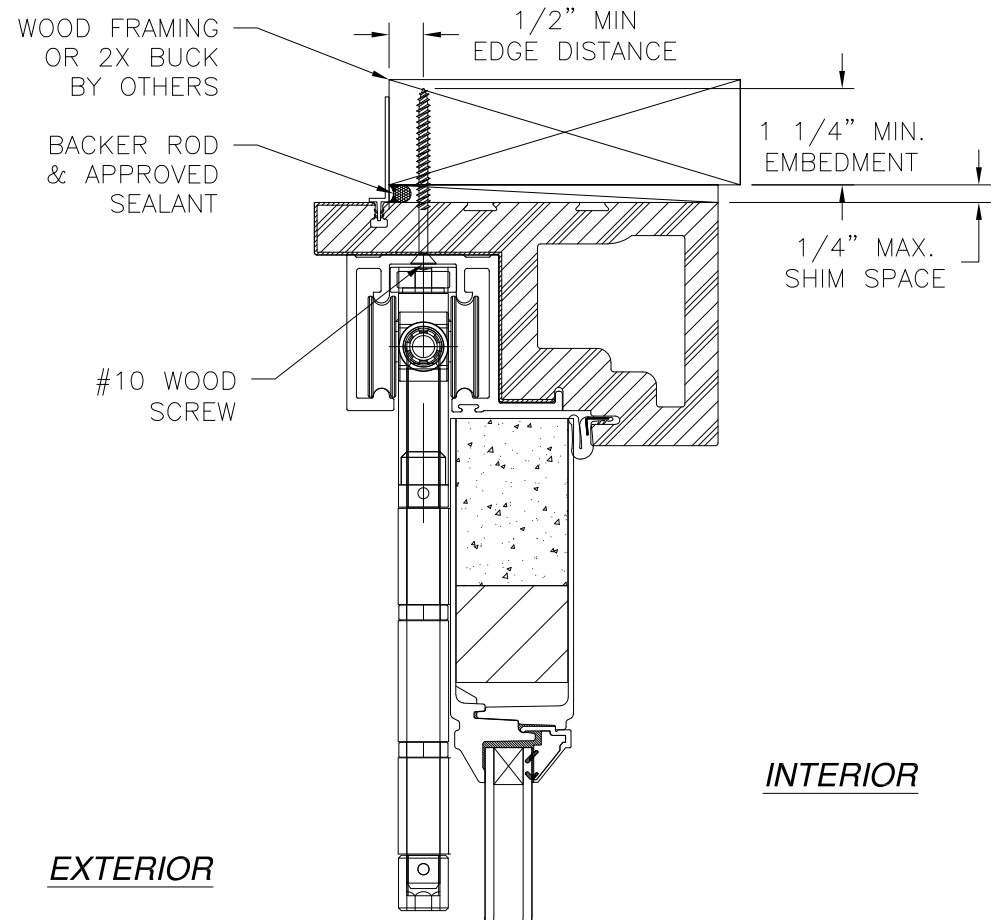

INTERIOR

EXTERIOR

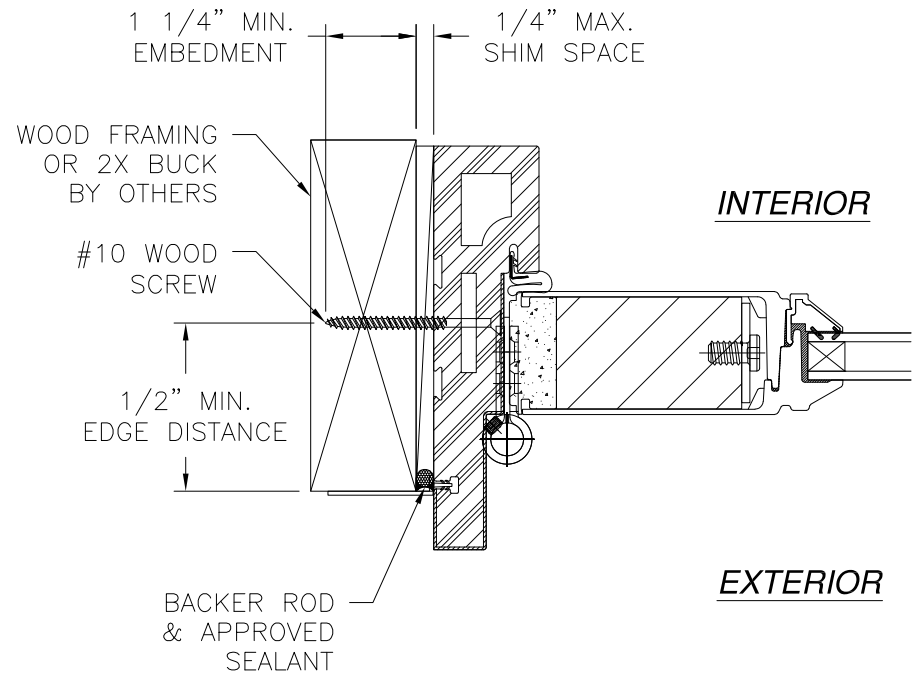

INTERIOR

EXTERIOR

JAMB INSTALLATION DETAIL
WOOD FRAMING OR 2X BUCK INSTALLATION

- NOTES:**
1. INTERIOR AND EXTERIOR FINISHES, BY OTHERS, NOT SHOWN FOR CLARITY.
 2. PERIMETER AND JOINT SEALANT BY OTHERS TO BE DESIGNED IN ACCORDANCE WITH ASTM E2112

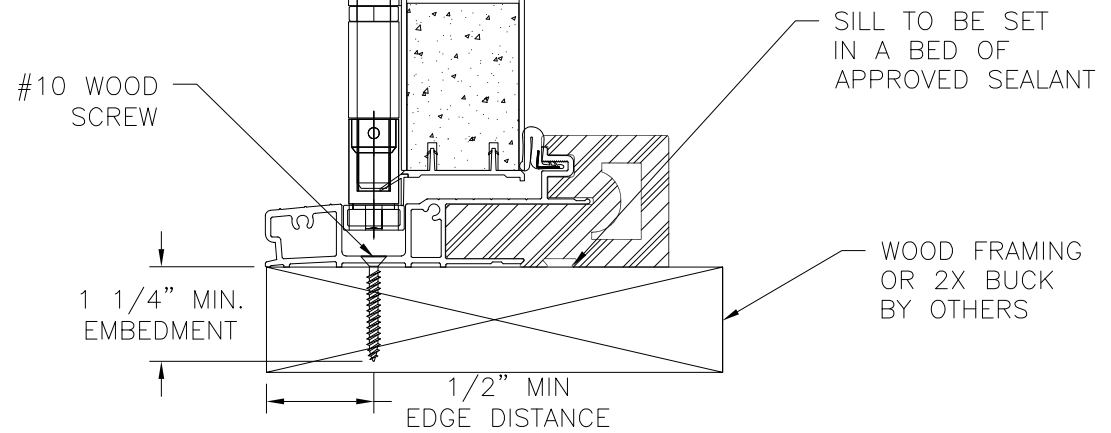

VERTICAL CROSS SECTION
WOOD FRAMING OR 2X BUCK INSTALLATION

SIGNED: 10/04/2021

<p>NAN YA PLASTICS CORP. USA 8989 NORTH LOOP EAST HOUSTON, TX 77029</p>		
<p>SERIES JBL FIBERGLASS OUT-SWING FOLDING DOOR NON-IMPACT INSTALLATION DETAILS</p>		
DRAWN: N.G.	DWG NO. 08-02883	REV A
SCALE NTS	DATE 02/24/16	SHEET 3 OF 6
<p>L. ROBERTO LOMAS P.E. 1432 WOODFORD RD LEWISVILLE, NC 27023 434-688-0609 rllomas@rlomaspe.com</p>		



Luis R. Lomas P.E.
TX No.: 101889

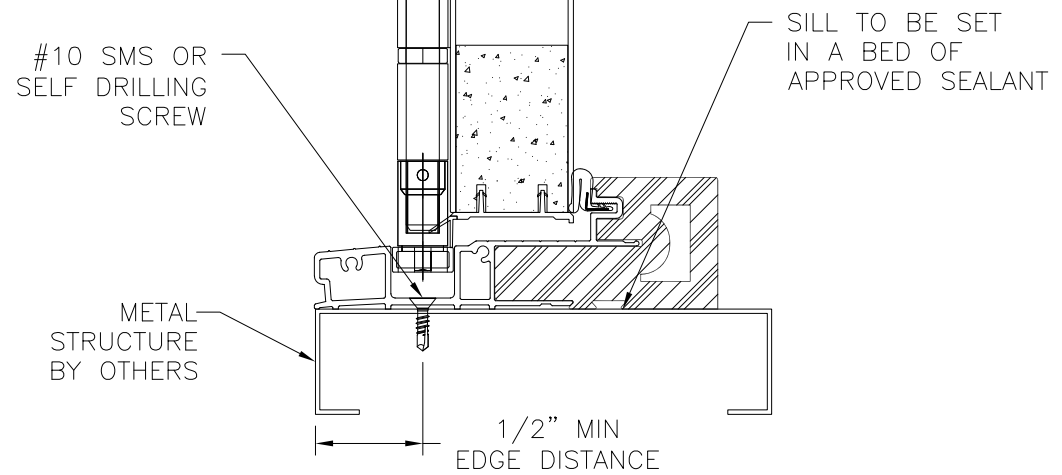
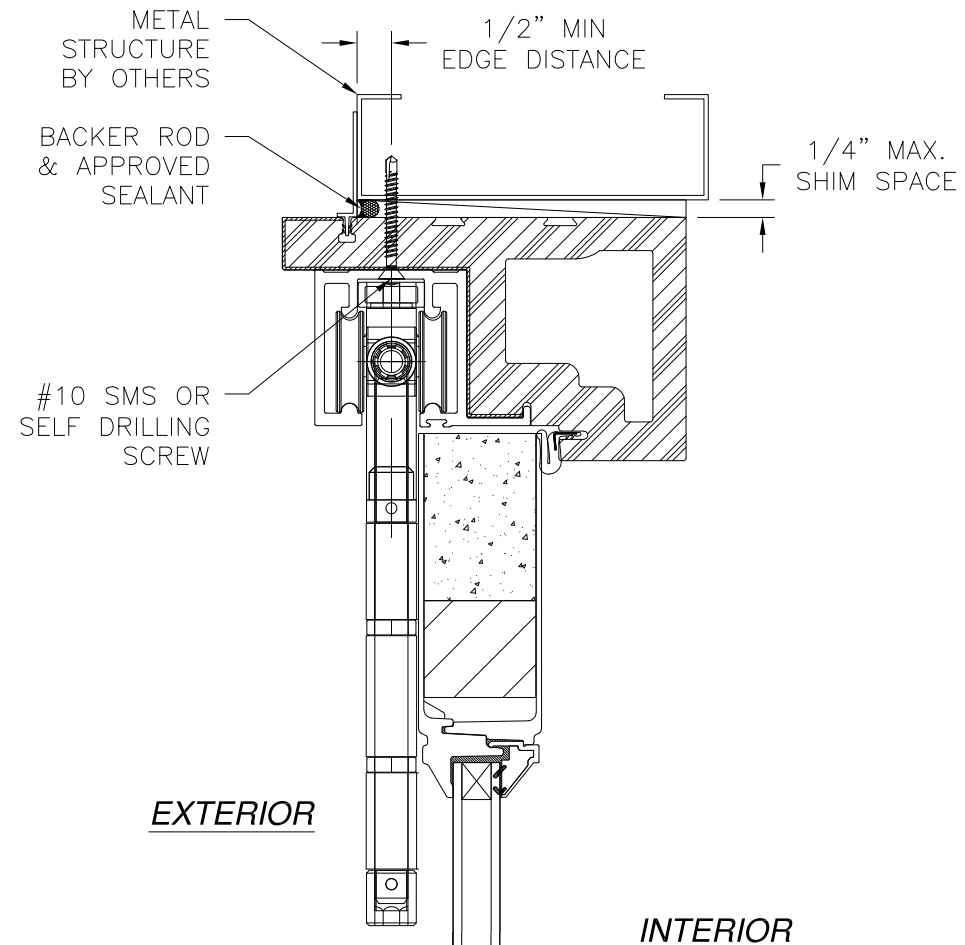

**VERTICAL CROSS SECTION
METAL STRUCTURE INSTALLATION**

REVISIONS			
REV	DESCRIPTION	DATE	APPROVED
A	UPDATED PER NEW CODES	10/04/2021	R.L.

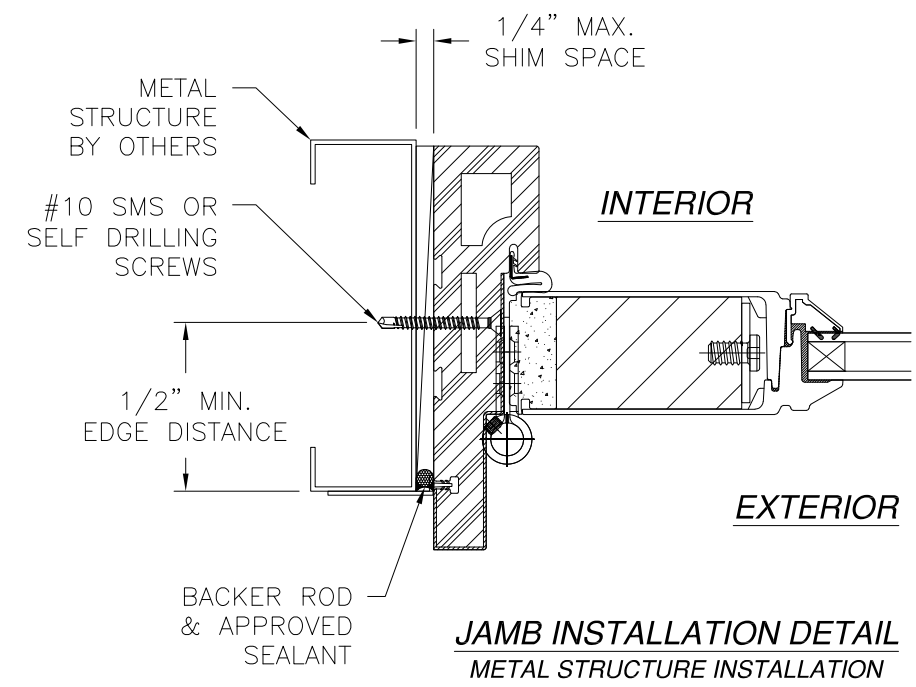

**JAMB INSTALLATION DETAIL
METAL STRUCTURE INSTALLATION**

- NOTES:**
1. INTERIOR AND EXTERIOR FINISHES, BY OTHERS, NOT SHOWN FOR CLARITY.
 2. PERIMETER AND JOINT SEALANT BY OTHERS TO BE DESIGNED IN ACCORDANCE WITH ASTM E2112

SIGNED: 10/04/2021

NAN YA PLASTICS CORP. USA
8989 NORTH LOOP EAST
HOUSTON, TX 77029

SERIES JBL FIBERGLASS OUT-SWING
FOLDING DOOR NON-IMPACT
INSTALLATION DETAILS

DRAWN: N.G.	DWG NO. 08-02883	REV A
SCALE NTS	DATE 02/24/16	SHEET 4 OF 6

L. ROBERTO LOMAS P.E.
1432 WOODFORD RD LEWISVILLE, NC 27023
434-688-0609 rllomas@lrlomaspe.com



Luis R. Lomas P.E.
TX No.: 101889

REVISIONS			
REV	DESCRIPTION	DATE	APPROVED
A	UPDATED PER NEW CODES	10/04/2021	R.L.

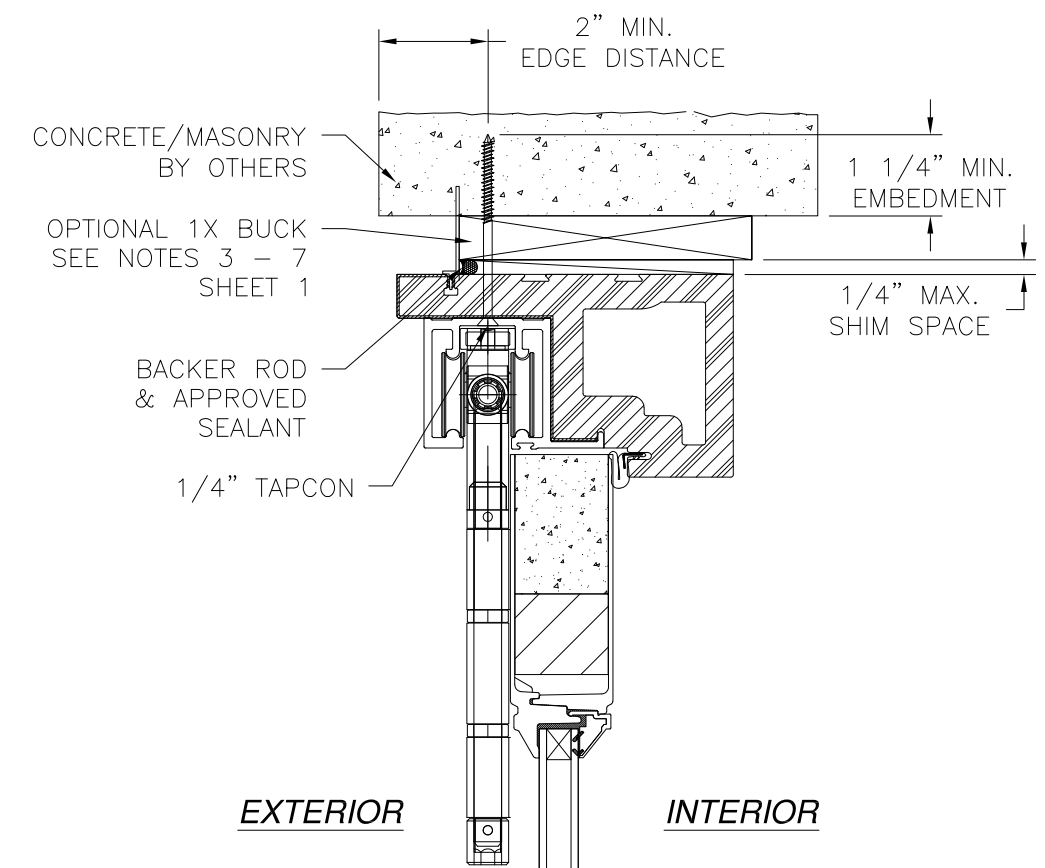

EXTERIOR INTERIOR

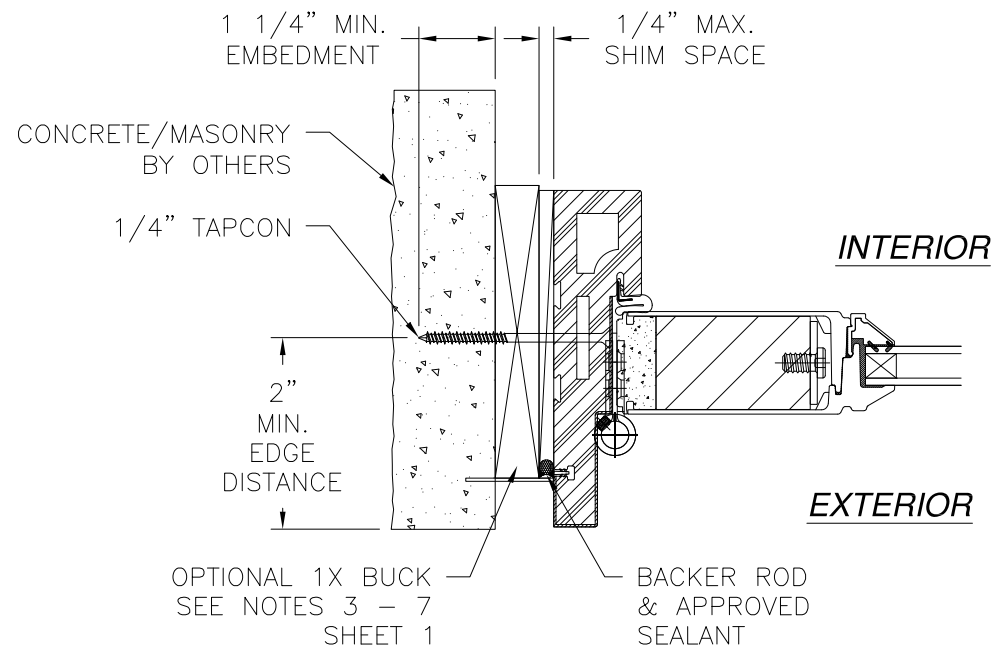

JAMB INSTALLATION DETAIL
CONCRETE/MASONRY INSTALLATION

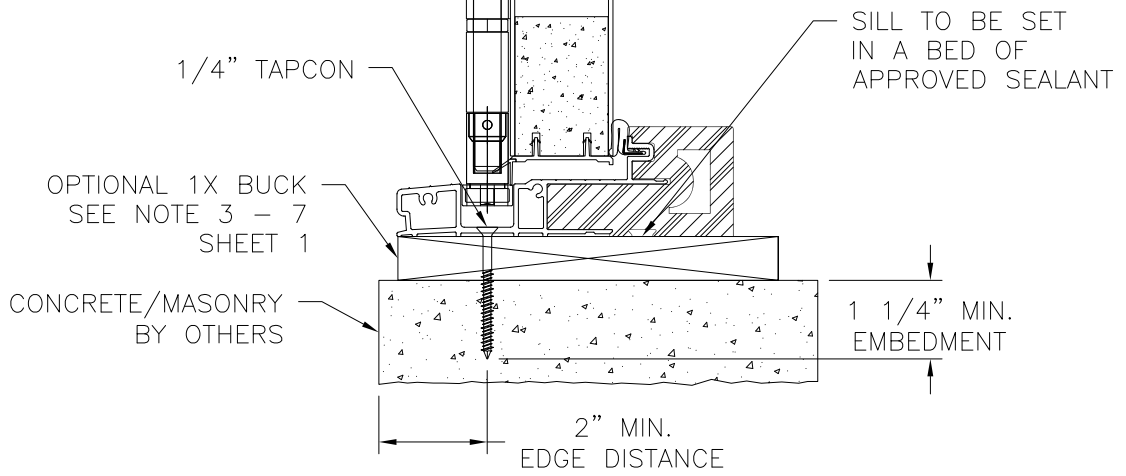

VERTICAL CROSS SECTION
CONCRETE/MASONRY INSTALLATION

- NOTES:**
1. INTERIOR AND EXTERIOR FINISHES, BY OTHERS, NOT SHOWN FOR CLARITY.
 2. PERIMETER AND JOINT SEALANT BY OTHERS TO BE DESIGNED IN ACCORDANCE WITH ASTM E2112

SIGNED: 10/04/2021

NAN YA PLASTICS CORP. USA
8989 NORTH LOOP EAST
HOUSTON, TX 77029

SERIES JBL FIBERGLASS OUT-SWING
FOLDING DOOR NON-IMPACT
INSTALLATION DETAILS

DRAWN: N.G.	DWG NO. 08-02883	REV A
SCALE NTS	DATE 02/24/16	SHEET 5 OF 6

L. ROBERTO LOMAS P.E.
1432 WOODFORD RD LEWISVILLE, NC 27023
434-688-0609 rllomas@rlomaspe.com



Luis R. Lomas P.E.
TX No.: 101889

REVISIONS			
REV	DESCRIPTION	DATE	APPROVED
A	UPDATED PER NEW CODES	10/04/2021	R.L.

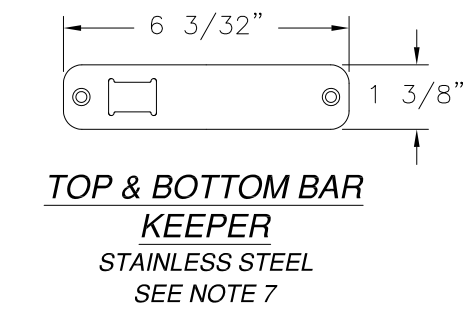
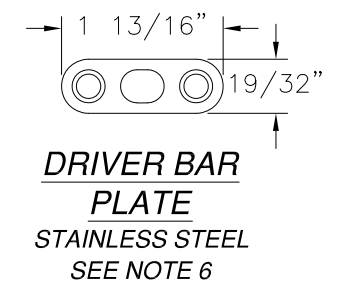
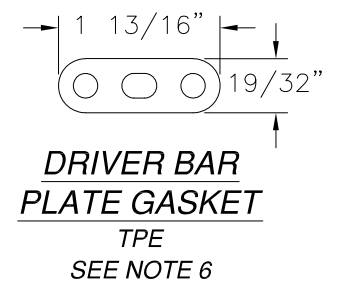
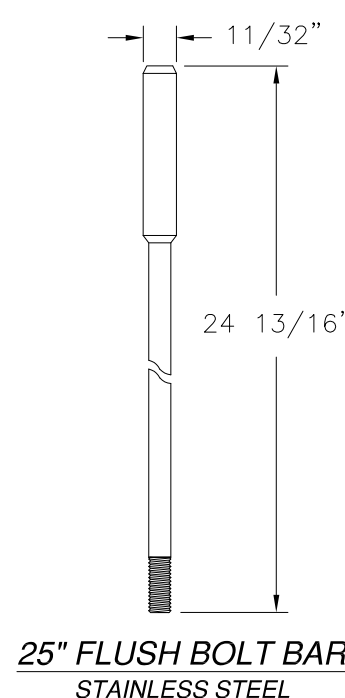
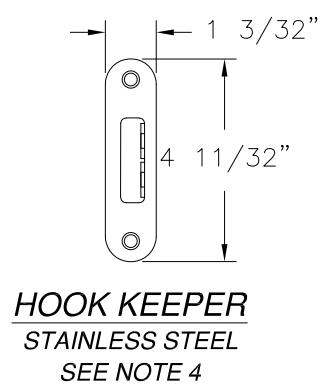
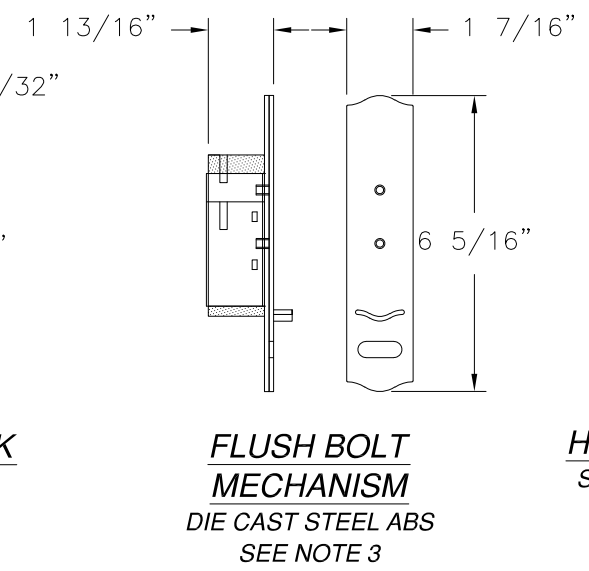
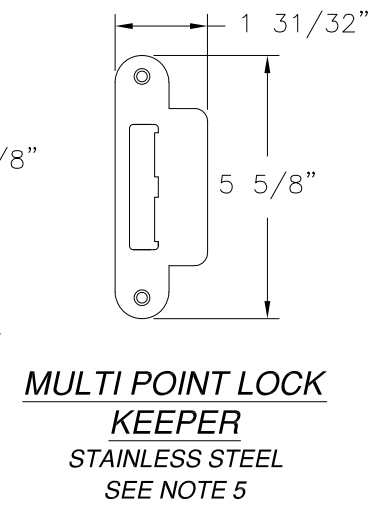
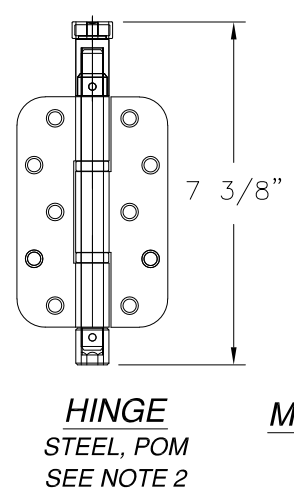
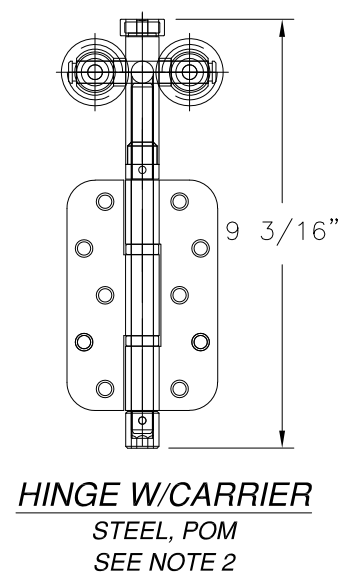
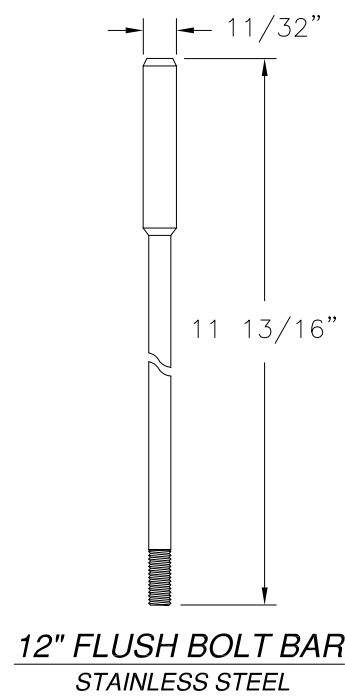
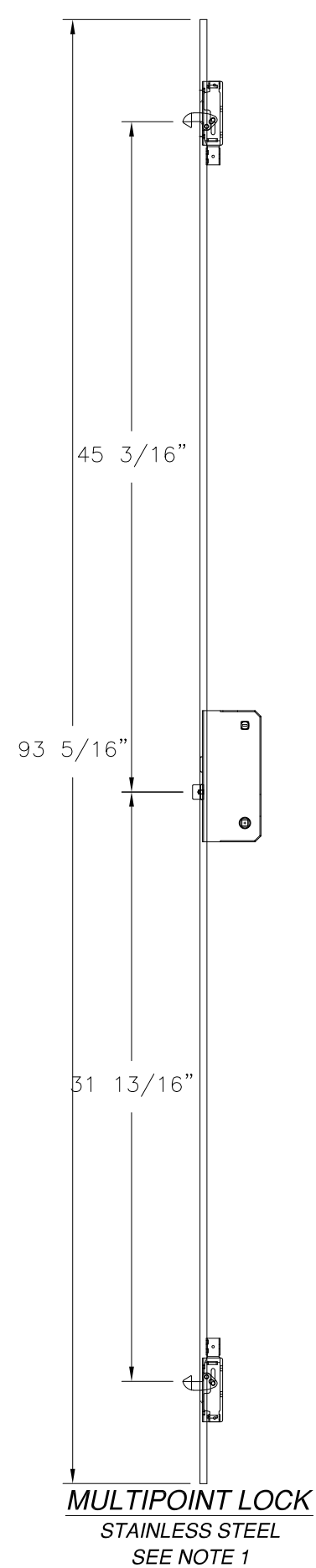

- NOTES:
1. INSTALL MULTI-POINT LOCK USING (13) #9 X 1 1/2" WOOD SCREWS.
 2. INSTALL HINGES USING (10) #10 X 3/4" WOOD SCREWS.
 3. INSTALL FLUSH BOLT MECHANISM USING (4) #9 X 7/8" WOOD SCREWS.
 4. INSTALL HOOK KEEPER USING (2) #9 X 7/8" WOOD SCREWS.
 5. INSTALL MULTIPPOINT LOCK KEEPER USING (2) #9 X 7/8" WOOD SCREWS.
 6. INSTALL DRIVER BAR PLATE AND GASKET USING (2) #9 X 7/8" WOOD SCREWS.
 7. INSTALL TOP & BOTTOM BAR KEEPER USING (2) #9 X 7/8" WOOD SCREWS.

SIGNED: 10/04/2021

NAN YA PLASTICS CORP. USA
8989 NORTH LOOP EAST
HOUSTON, TX 77029

SERIES JBL FIBERGLASS OUT-SWING
FOLDING DOOR NON-IMPACT
HARDWARE COMPONENTS

DRAWN: N.G.	DWG NO. 08-02883	REV A
SCALE NTS	DATE 02/24/16	SHEET 6 OF 6

L. ROBERTO LOMAS P.E.
1432 WOODFORD RD LEWISVILLE, NC 27023
434-688-0609 rllomas@rlomaspe.com



Luis R. Lomas P.E.
TX No.: 101889