

REVISIONS			
REV	DESCRIPTION	DATE	APPROVED
A	REVISED PER NEW REQUIREMENTS	02/17/2020	R.L.

NOTES:

1. THE PRODUCT SHOWN HEREIN IS DESIGNED AND MANUFACTURED TO COMPLY WITH REQUIREMENTS OF THE 2018 IBC AND 2018 IRC.
2. WOOD FRAMING AND MASONRY OPENING TO BE DESIGNED AND ANCHORED TO PROPERLY TRANSFER ALL LOADS TO STRUCTURE. FRAMING AND MASONRY OPENING IS THE RESPONSIBILITY OF THE ARCHITECT OR ENGINEER OF RECORD.
3. 1X BUCK OVER MASONRY/CONCRETE IS OPTIONAL.
4. WHERE SHIM OR BUCK THICKNESS IS LESS THAN 1-1/2" UNITS MUST BE ANCHORED THROUGH THE FRAME IN ACCORDANCE WITH MANUFACTURER'S PUBLISHED INSTALLATION INSTRUCTIONS. ANCHORS SHALL BE SECURELY FASTENED DIRECTLY INTO MASONRY, CONCRETE OR OTHER STRUCTURAL SUBSTRATE MATERIAL.
5. WHERE WOOD BUCK THICKNESS IS 1-1/2" OR GREATER, BUCK SHALL BE SECURELY FASTENED TO MASONRY, CONCRETE OR OTHER STRUCTURAL SUBSTRATE. UNITS MAY BE ANCHORED THROUGH FRAME TO SECURED WOOD BUCK IN ACCORDANCE WITH MANUFACTURER'S PUBLISHED INSTALLATION INSTRUCTIONS.
6. WHERE 1X BUCK IS NOT USED DISSIMILAR MATERIALS MUST BE SEPARATED WITH APPROVED COATING OR MEMBRANE. SELECTION OF COATING OR MEMBRANE IS THE RESPONSIBILITY OF THE ARCHITECT OR ENGINEER OF RECORD.
7. BUCKS SHALL EXTEND BEYOND UNIT FRAME INTERIOR FACE SO THAT FULL FRAME SUPPORT IS PROVIDED.
8. SHIM AS REQUIRED AT EACH ANCHOR LOCATION WITH LOAD BEARING SHIM. SHIM WHERE SPACE OF 1/16" OR GREATER OCCURS. MAXIMUM ALLOWABLE SHIM STACK TO BE 1/4".
9. SHIMS SHALL BE LOCATED, APPLIED AND MADE FROM MATERIALS AND THICKNESS CAPABLE OF SUSTAINING APPLICABLE LOADS.
10. WIND LOAD DURATION FACTOR Cd=1.6 WAS USED FOR WOOD ANCHOR CALCULATIONS.
11. FRAME MATERIAL: ALUMINUM 6063-T5, 6063-T6 AND 6005A-T5.
12. UNITS MUST BE GLAZED PER ASTM E1300, SEE SHEET 6 FOR GLASS DETAILS.
13. APPROVED IMPACT PROTECTIVE SYSTEM IS NOT REQUIRED FOR THIS PRODUCT IN WIND BORNE DEBRIS REGIONS.
14. FOR ANCHORING THROUGH FRAME INTO WOOD FRAMING OR 2X BUCK USE #14 WOOD SCREWS WITH SUFFICIENT LENGTH TO ACHIEVE A 1 7/16" MINIMUM EMBEDMENT INTO SUBSTRATE. LOCATE ANCHORS AS SHOWN IN ELEVATIONS AND INSTALLATION DETAILS.

15. FOR ANCHORING THROUGH FRAME INTO MASONRY/CONCRETE USE 1/4" ELCO CRETE-FLEX WITH SUFFICIENT LENGTH TO ACHIEVE A 1 1/4" MINIMUM EMBEDMENT INTO SUBSTRATE WITH 1 3/4" MINIMUM EDGE DISTANCE. LOCATE ANCHORS AS SHOWN IN ELEVATIONS AND INSTALLATION DETAILS.
16. FOR ANCHORING THROUGH FRAME INTO METAL STRUCTURE USE #14 SMS OR SELF DRILLING SCREWS WITH SUFFICIENT LENGTH TO ACHIEVE 3 THREADS MINIMUM BEYOND STRUCTURE INTERIOR WALL. LOCATE ANCHORS AS SHOWN IN ELEVATIONS AND INSTALLATION DETAILS.
17. ALL FASTENERS TO BE CORROSION RESISTANT.
18. INSTALLATION ANCHORS SHALL BE INSTALLED IN ACCORDANCE WITH ANCHOR MANUFACTURER'S INSTALLATION INSTRUCTIONS AND ANCHORS SHALL NOT BE USED IN SUBSTRATES WITH STRENGTHS LESS THAN THE MINIMUM STRENGTH SPECIFIED BELOW:
  - A. WOOD: MINIMUM SPECIFIC GRAVITY OF G=0.42
  - B. CONCRETE: MINIMUM COMPRESSIVE STRENGTH OF 3,000 PSI.
  - C. MASONRY: GROUT/FILLED BLOCK PER ASTM C90 WITH Fm=2,000PSI MINIMUM.
  - D. METAL STRUCTURE: STEEL 18GA (.048") FY=33KSI/FU=52KSI OR ALUMINUM 6063-T5 FU=30KSI .125" THICK MINIMUM

SIGNED: 04/27/2021

TABLE OF CONTENTS	
SHEET NO.	DESCRIPTION
1	NOTES
2	ELEVATIONS
3	ANCHORING LAYOUT
4 - 6	CROSS SECTIONS
7 - 8	INSTALLATION DETAILS
9	WEEP DETAILS
10	COMPONENTS

<b>SOLAR INNOVATIONS, INC.</b> 31 ROBERTS RD. PINE GROVE, PA 17963		
SI 33350 G3 IMPACT FGW 3.5' X 9.5' PANEL 90° CORNER NO-POST - FLUSH SILL NOTES		
DRAWN: N.G.	DWG NO. 08-02639	REV A
SCALE NTS	DATE 03/19/15	SHEET 1 OF 10
L. ROBERTO LOMAS P.E. 1432 WOODFORD RD LEWISVILLE, NC 27023 434-688-0609 rllomas@lrlomaspe.com		



Luis R. Lomas P.E.  
TX No.: 101889

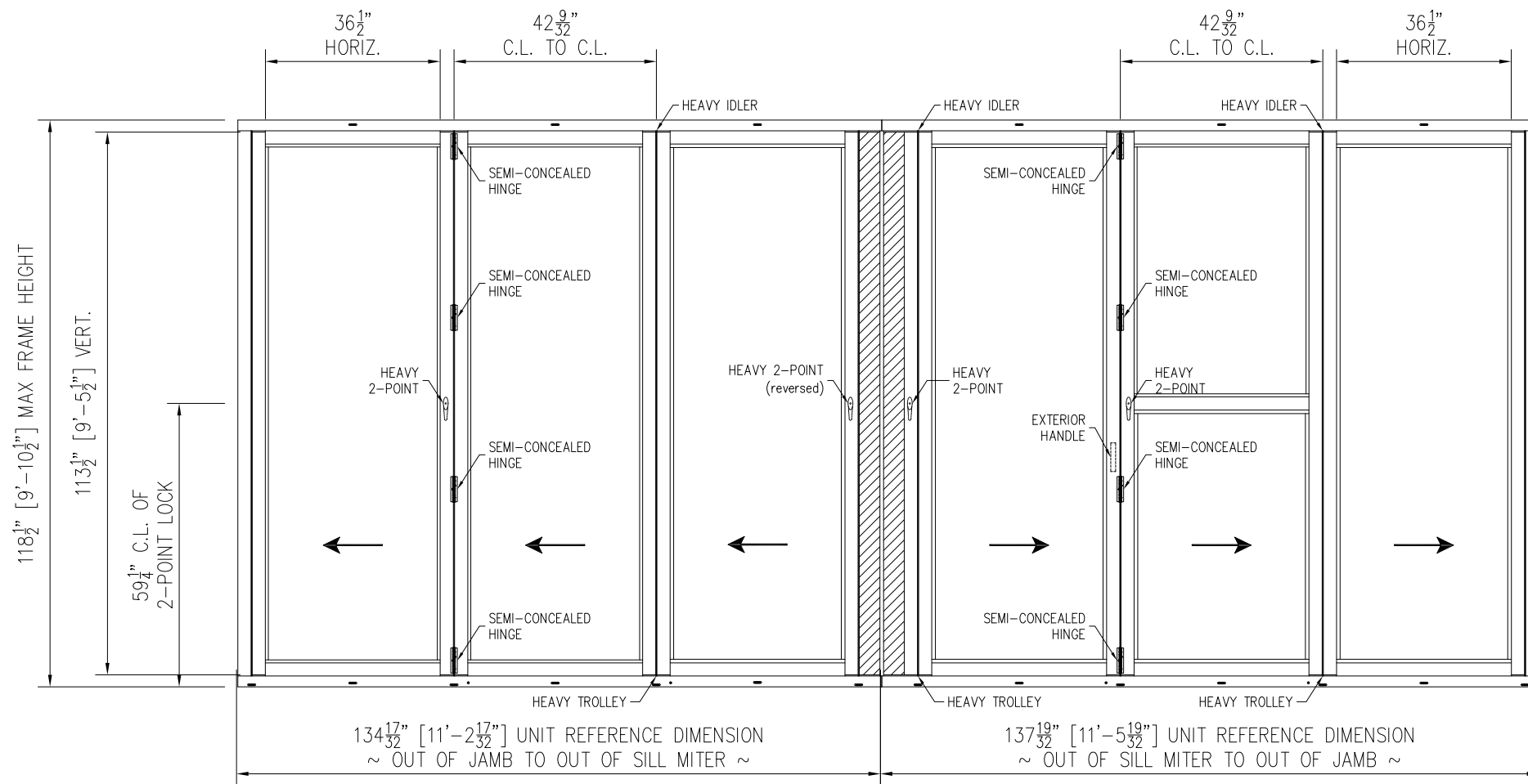

**SI 33350 G3 IMPACT FGW 3.5X9.5 PANEL 90° CORNER NO-POST - FLUSH SILL**  
EXTERIOR VIEW

DESIGN PRESSURE RATING	IMPACT RATING
±55.0PSF	LARGE AND SMALL MISSILE IMPACT

MISSILE LEVEL D, WIND ZONE 4  
MULTIPLE PANELS CONFIGURATIONS ARE APPROVED AS LONG AS INDIVIDUAL PANEL SIZE DOES NOT EXCEED 42 9/32" WIDTH AND 113 1/2" HEIGHT

**HARDWARE SCHEDULE**

- A. SEMI-CONCEALED HINGE BY SOLAR INNOVATIONS
- B. 2 POINT HANDLE & LOCK MS000487-XX BY SOLAR INNOVATIONS

REVISIONS			
REV	DESCRIPTION	DATE	APPROVED
A	REVISED PER NEW REQUIREMENTS	02/17/2020	R.L.

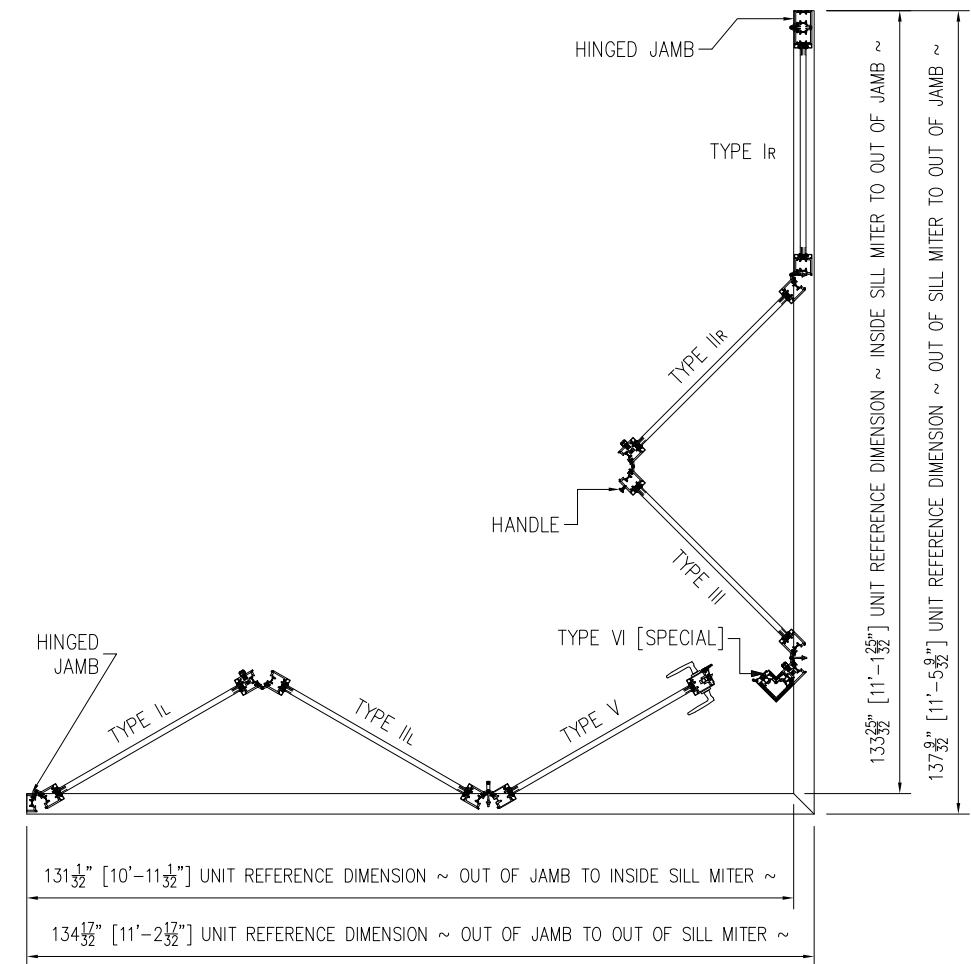

**SI 33350 G3 IMPACT FGW 3.5X9.5 PANEL 90° CORNER NO-POST - FLUSH SILL**  
PLAN VIEW

SIGNED: 04/27/2021

SOLAR INNOVATIONS, INC.  
31 ROBERTS RD.  
PINE GROVE, PA 17963

SI 33350 G3 IMPACT FGW 3.5' X 9.5' PANEL  
90° CORNER NO-POST - FLUSH SILL  
ELEVATIONS

DRAWN: N.G.	DWG NO. 08-02639	REV A
SCALE NTS	DATE 03/19/15	SHEET 2 OF 10

L. ROBERTO LOMAS P.E.  
1432 WOODFORD RD LEWISVILLE, NC 27023  
434-688-0609 rllomas@rlomaspe.com



Luis R. Lomas P.E.  
TX No.: 101889

REVISIONS			
REV	DESCRIPTION	DATE	APPROVED
A	REVISED PER NEW REQUIREMENTS	02/17/2020	R.L.

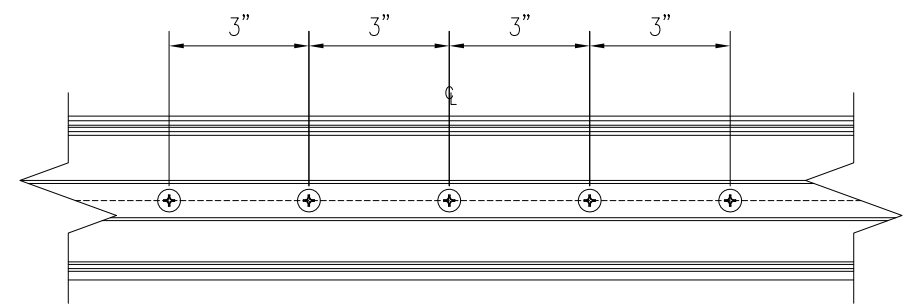
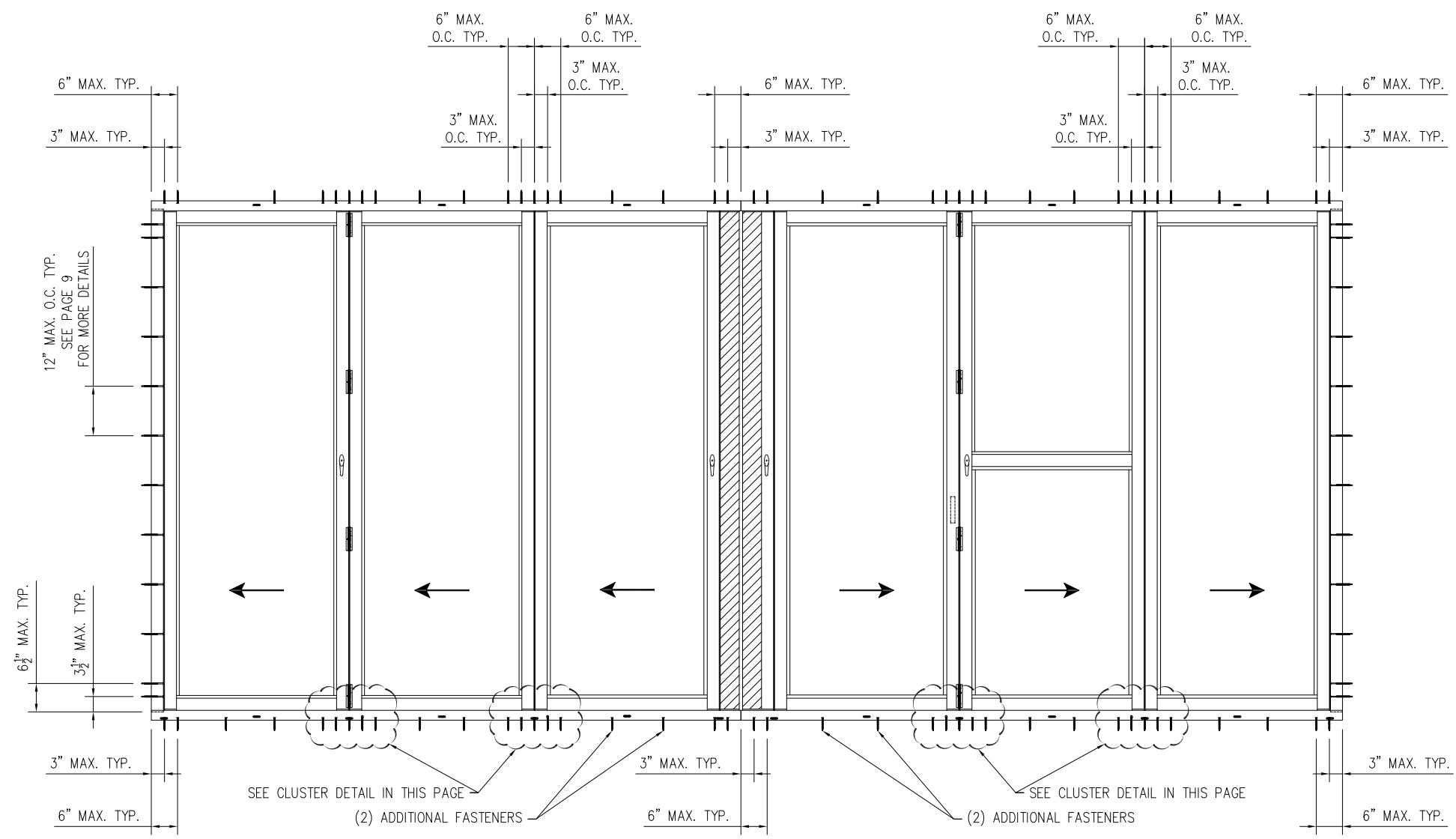

SILL AND HEAD CLUSTER DETAIL

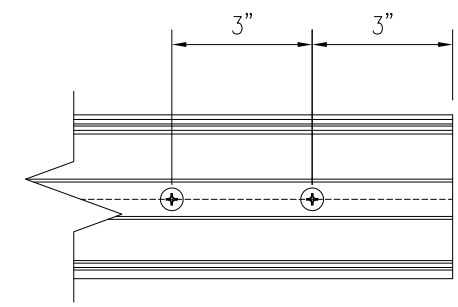

SILL AND HEAD END DETAIL

**ANCHOR LAYOUT**  
APPLICABLE TO ALL CONFIGURATIONS.

SIGNED: 04/27/2021

SOLAR INNOVATIONS, INC.  
31 ROBERTS RD.  
PINE GROVE, PA 17963

SI 33350 G3 IMPACT FGW 3.5' X 9.5' PANEL  
90° CORNER NO-POST - FLUSH SILL  
ANCHORING LAYOUT

DRAWN: N.G.	DWG NO. 08-02639	REV A
SCALE NTS	DATE 03/19/15	SHEET 3 OF 10

L. ROBERTO LOMAS P.E.  
1432 WOODFORD RD LEWISVILLE, NC 27023  
434-688-0609 rllomas@rlomaspe.com



Luis R. Lomas P.E.  
TX No.: 101889

**FOR ILLUSTRATION PURPOSES ONLY  
FOR INSTALLATION DETAILS REFER TO SHEETS 7 - 8**

REVISIONS			
REV	DESCRIPTION	DATE	APPROVED
A	REVISED PER NEW REQUIREMENTS	02/17/2020	R.L.

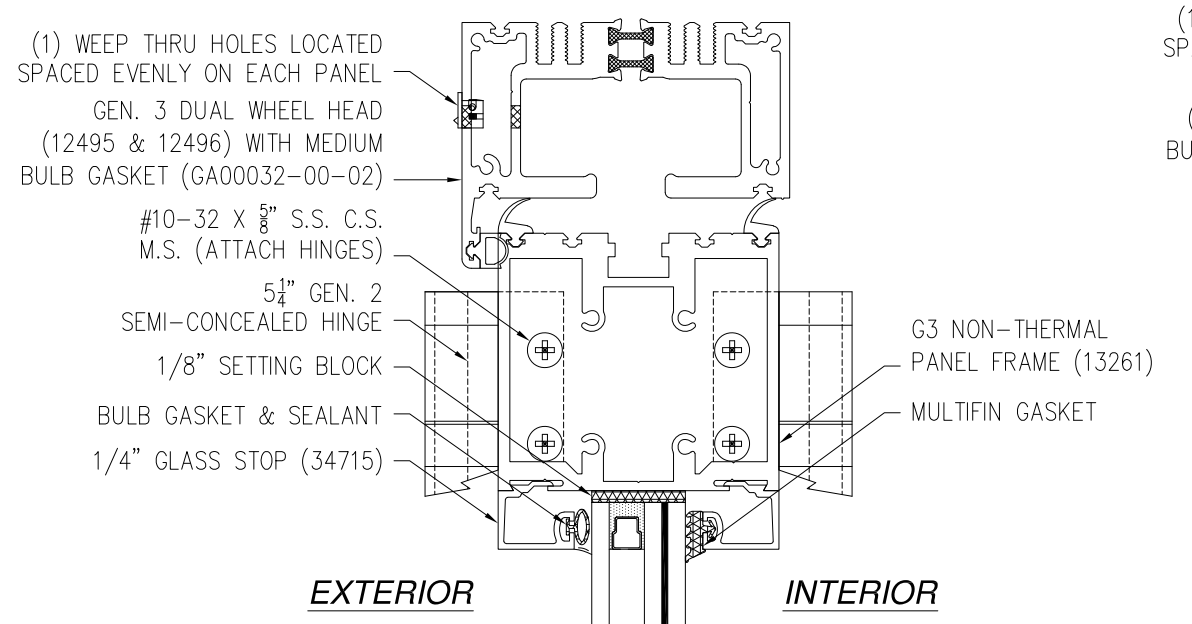

**EXTERIOR** **INTERIOR**

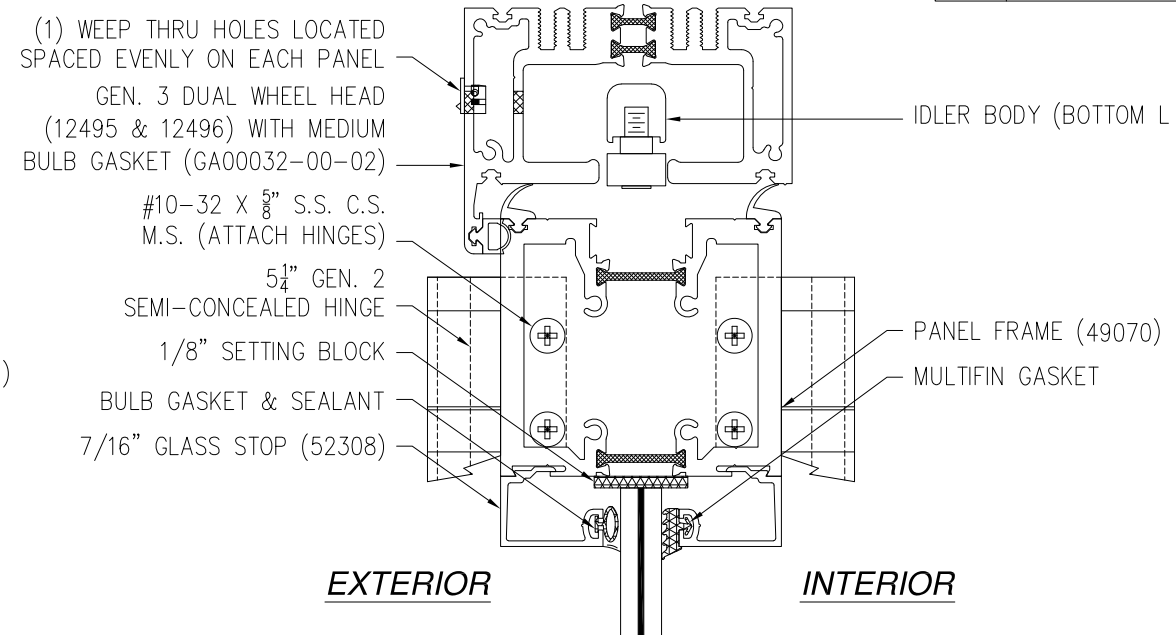

**EXTERIOR** **INTERIOR**

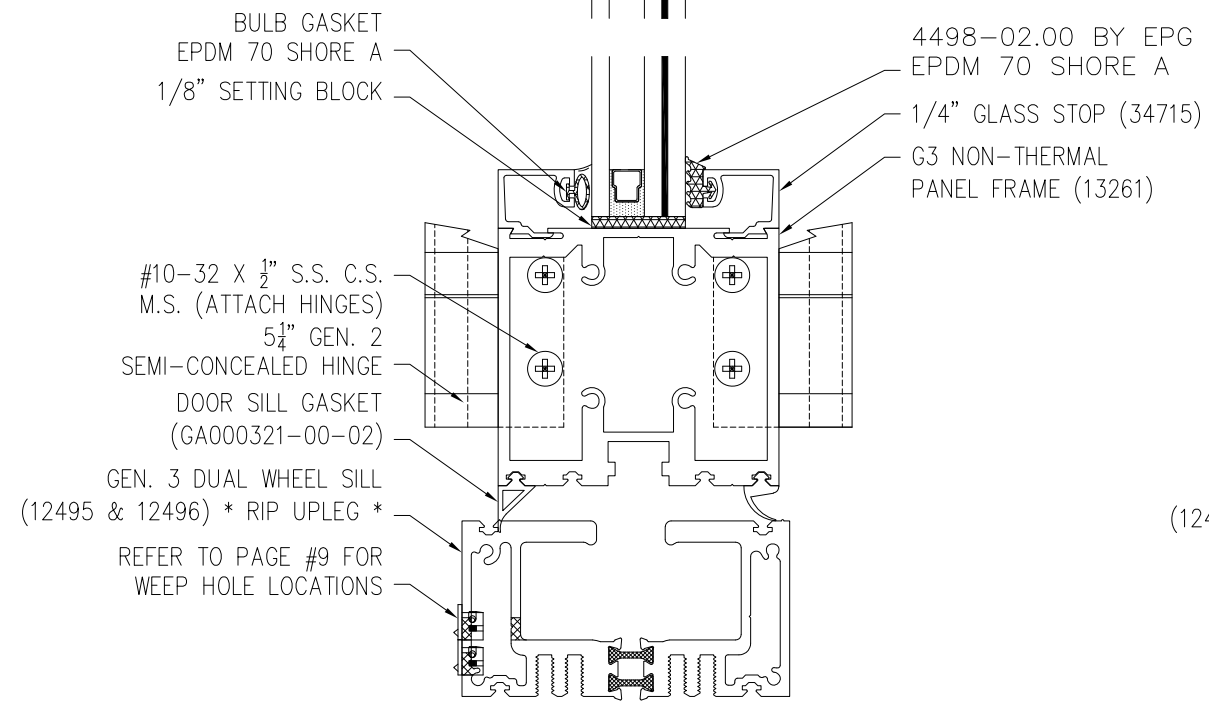

**VERTICAL CROSS SECTION  
STANDARD**

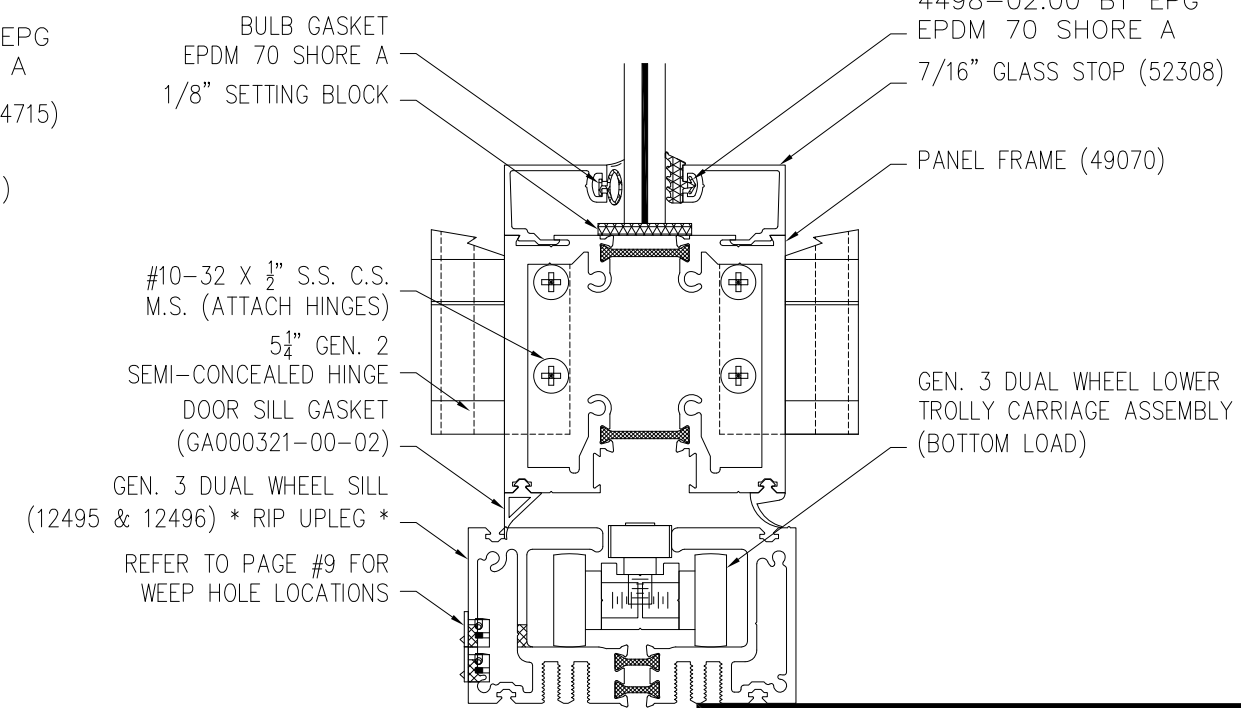

**VERTICAL CROSS SECTION  
BOTTOM LOAD SILL**

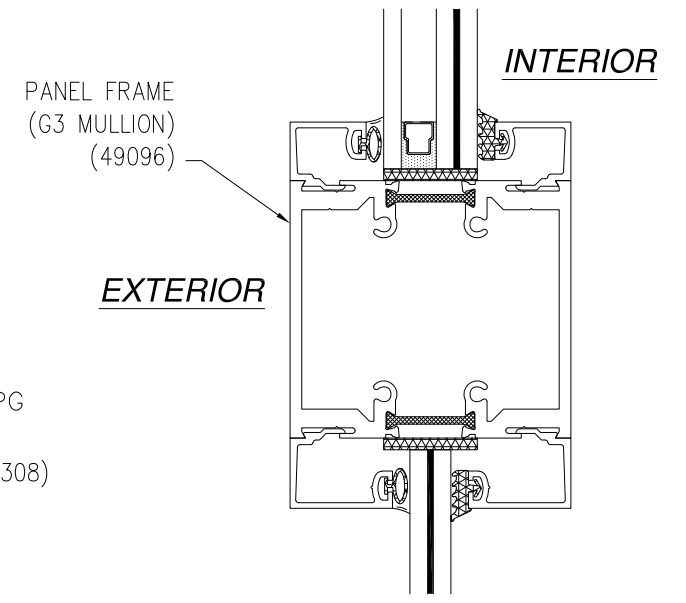

**VERTICAL CROSS SECTION  
HORIZONTAL RAIL OPTIONAL**

SIGNED: 04/27/2021

**SOLAR INNOVATIONS, INC.**  
31 ROBERTS RD.  
PINE GROVE, PA 17963

SI 33350 G3 IMPACT FGW 3.5' X 9.5' PANEL  
90° CORNER NO-POST - FLUSH SILL  
CROSS SECTIONS

DRAWN: N.G.	DWG NO. 08-02639	REV A
SCALE NTS	DATE 03/19/15	SHEET 4 OF 10

L. ROBERTO LOMAS P.E.  
1432 WOODFORD RD LEWISVILLE, NC 27023  
434-688-0609 rllomas@rlomaspe.com



Luis R. Lomas P.E.  
TX No.: 101889

REVISIONS			
REV	DESCRIPTION	DATE	APPROVED
A	REVISED PER NEW REQUIREMENTS	02/17/2020	R.L.

CONTINUED  
IN SHEET 6

FOR ILLUSTRATION PURPOSES ONLY  
FOR INSTALLATION DETAILS REFER TO SHEETS 7 - 8

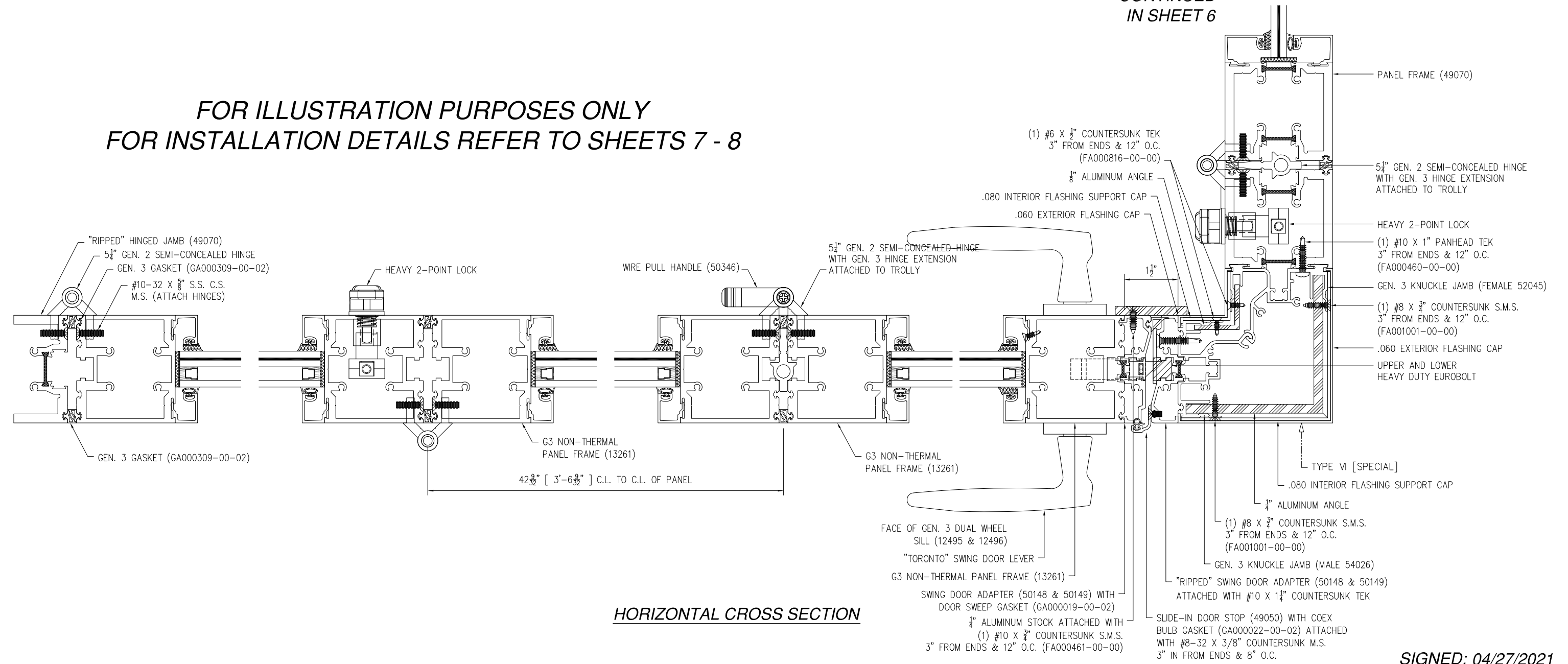

HORIZONTAL CROSS SECTION

SIGNED: 04/27/2021

SOLAR INNOVATIONS, INC.  
31 ROBERTS RD.  
PINE GROVE, PA 17963

SI 33350 G3 IMPACT FGW 3.5' X 9.5' PANEL  
90° CORNER NO-POST - FLUSH SILL  
CROSS SECTIONS

DRAWN: N.G.	DWG NO. 08-02639	REV A
SCALE NTS	DATE 03/19/15	SHEET 5 OF 10

L. ROBERTO LOMAS P.E.  
1432 WOODFORD RD LEWISVILLE, NC 27023  
434-688-0609 rllomas@lrlomaspe.com



Luis R. Lomas P.E.  
TX No.: 101889

**FOR ILLUSTRATION PURPOSES ONLY  
FOR INSTALLATION DETAILS REFER TO SHEETS 7 - 8**

REVISIONS			
REV	DESCRIPTION	DATE	APPROVED
A	REVISED PER NEW REQUIREMENTS	02/17/2020	R.L.

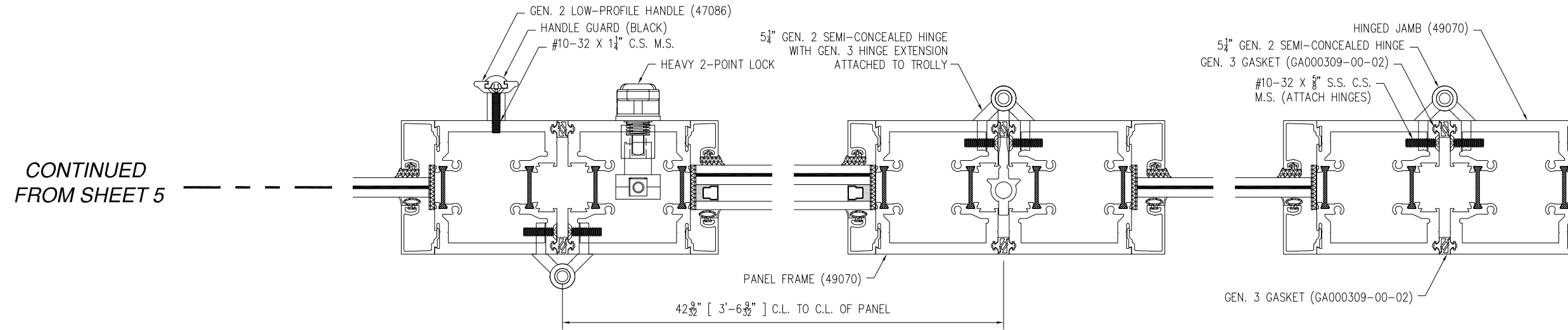

**HORIZONTAL CROSS SECTION**

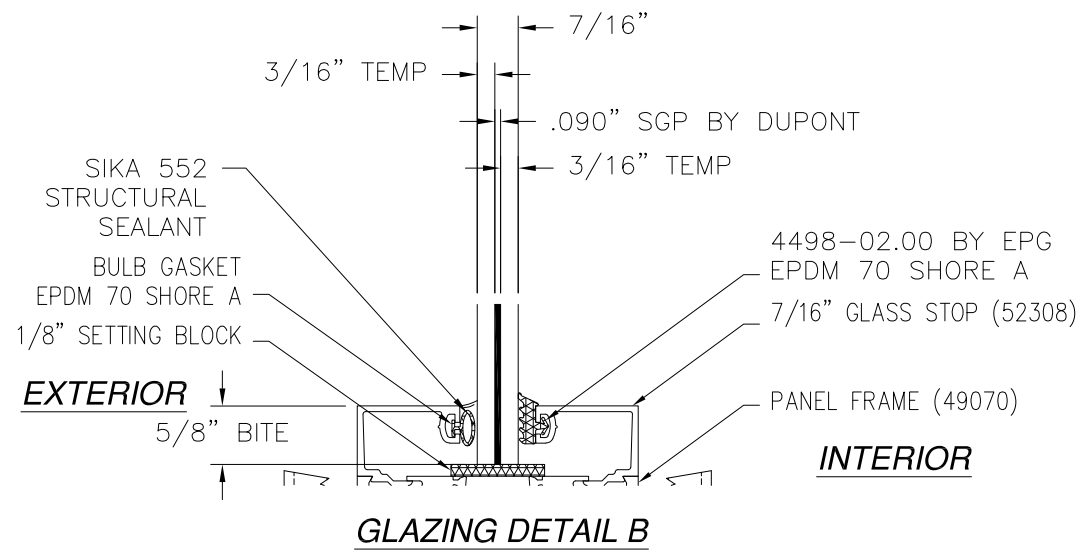
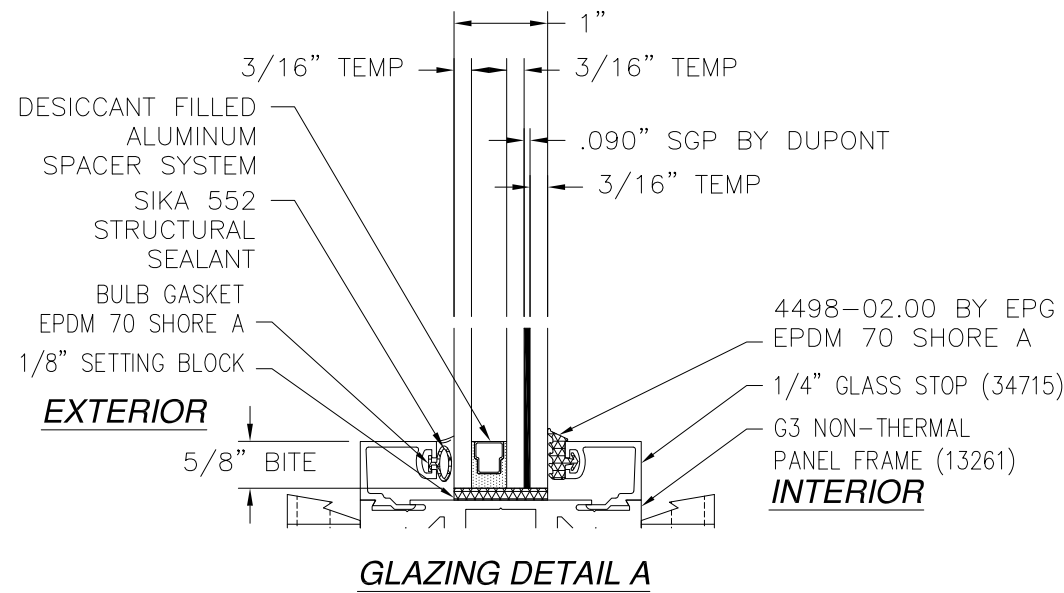

SIGNED: 04/27/2021

**SOLAR INNOVATIONS, INC.**  
31 ROBERTS RD.  
PINE GROVE, PA 17963

SI 33350 G3 IMPACT FGW 3.5' X 9.5' PANEL  
90° CORNER NO-POST - FLUSH SILL  
CROSS SECTIONS

DRAWN: N.G.	DWG NO. 08-02639	REV A
SCALE NTS	DATE 03/19/15	SHEET 6 OF 10

L. ROBERTO LOMAS P.E.  
1432 WOODFORD RD LEWISVILLE, NC 27023  
434-688-0609 rllomas@rlomaspe.com



Luis R. Lomas P.E.  
TX No.: 101889

REVISIONS			
REV	DESCRIPTION	DATE	APPROVED
A	REVISED PER NEW REQUIREMENTS	02/17/2020	R.L.

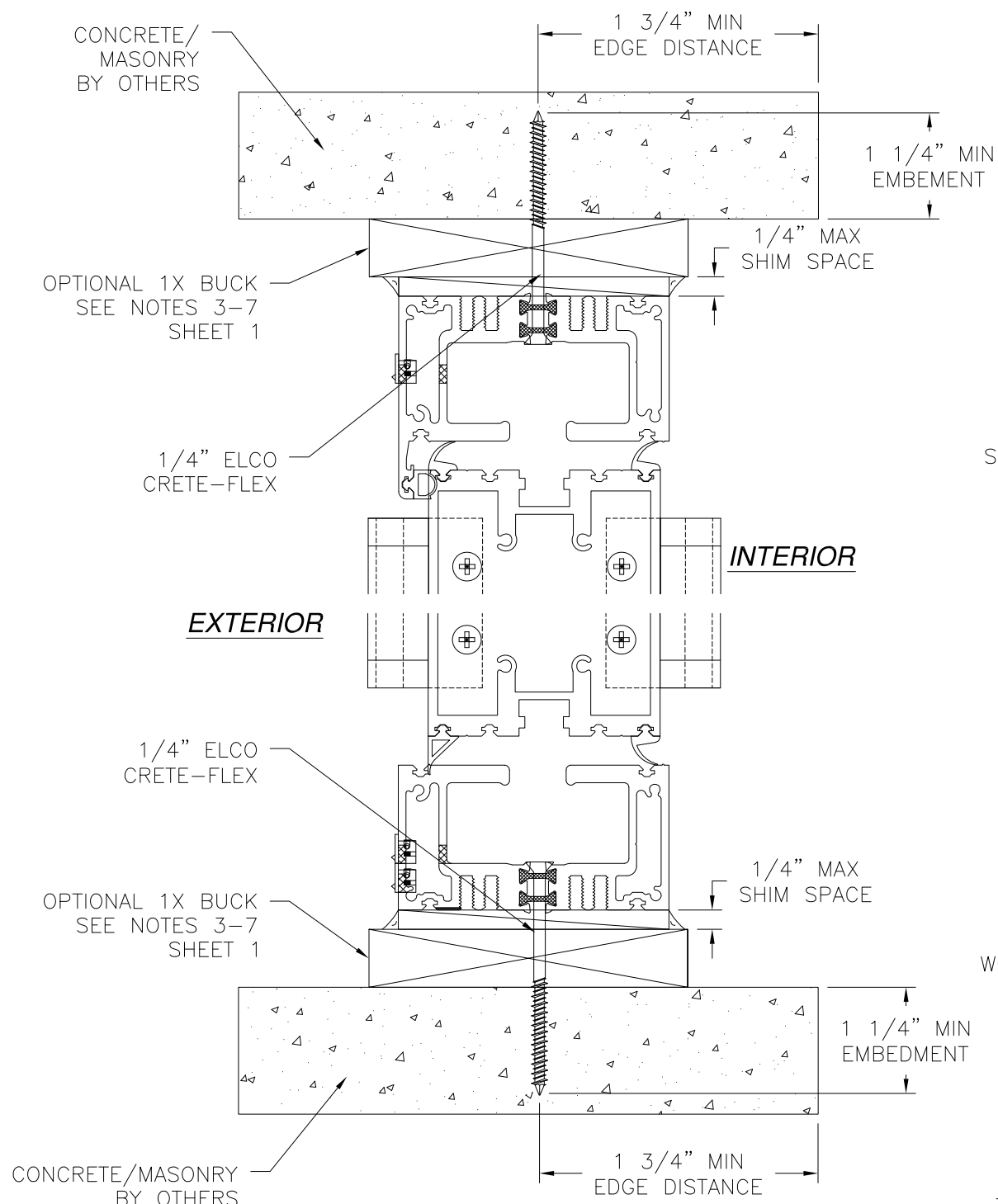

**VERTICAL CROSS SECTION**  
CONCRETE/MASONRY INSTALLATION

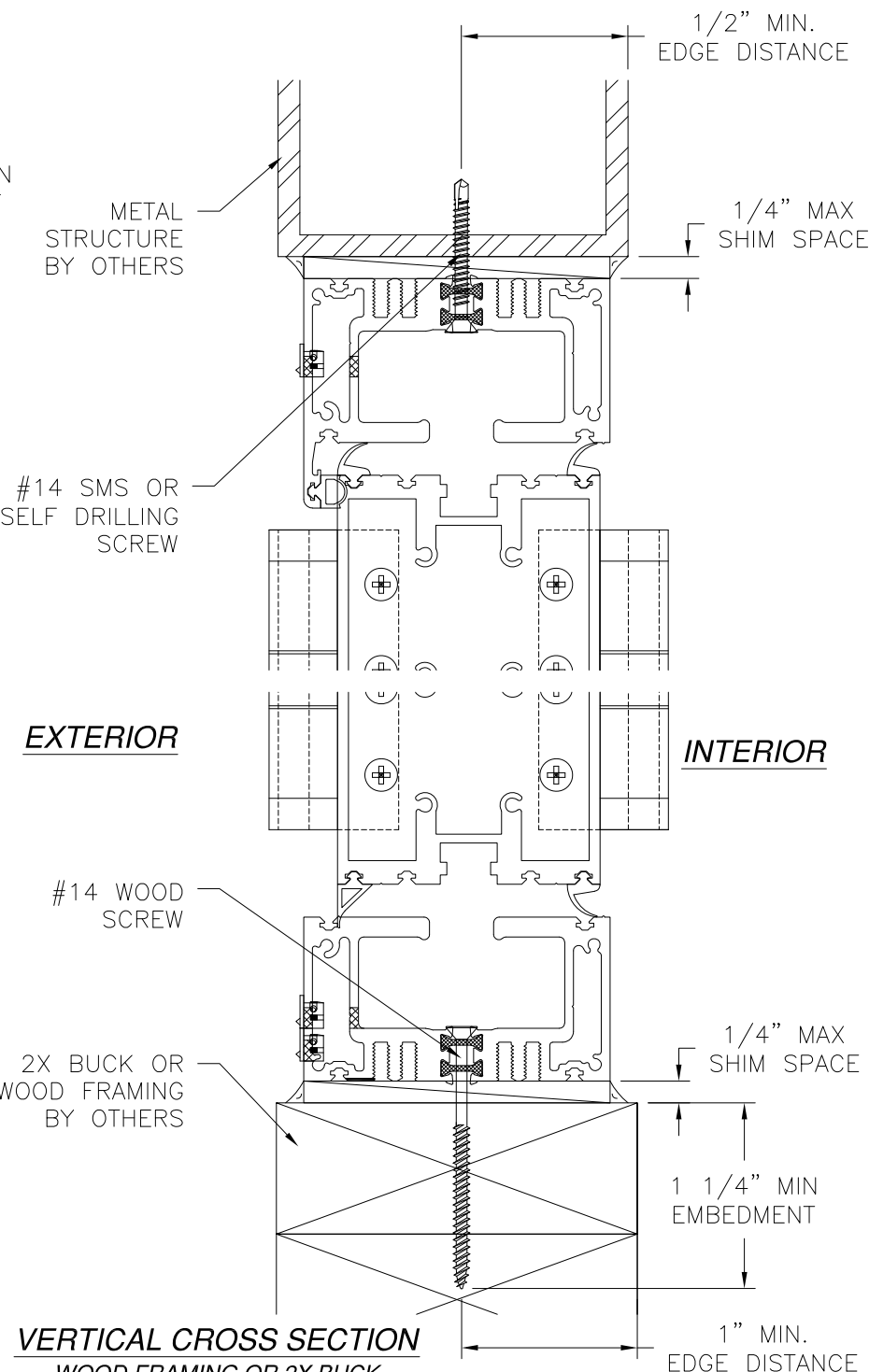

**VERTICAL CROSS SECTION**  
WOOD FRAMING OR 2X BUCK  
OR METAL STRUCTURE INSTALLATION

**NOTES:**  
 1. INTERIOR AND EXTERIOR FINISHES, BY OTHERS, NOT SHOWN FOR CLARITY.  
 2. PERIMETER AND JOINT SEALANT BY OTHERS TO BE DESIGNED IN ACCORDANCE WITH ASTM E2112

**SOLAR INNOVATIONS, INC.**  
 31 ROBERTS RD.  
 PINE GROVE, PA 17963

---

SI 33350 G3 IMPACT FGW 3.5' X 9.5' PANEL  
 90° CORNER NO-POST – FLUSH SILL  
 INSTALLATION DETAILS

DRAWN: N.G.	DWG NO. 08-02639	REV A
SCALE NTS	DATE 03/19/15	SHEET 7 OF 10

L. ROBERTO LOMAS P.E.  
 1432 WOODFORD RD LEWISVILLE, NC 27023  
 434-688-0609 rllomas@rlomaspe.com

SIGNED: 04/27/2021



Luis R. Lomas P.E.  
 TX No.: 101889

REVISIONS			
REV	DESCRIPTION	DATE	APPROVED
A	REVISED PER NEW REQUIREMENTS	02/17/2020	R.L.

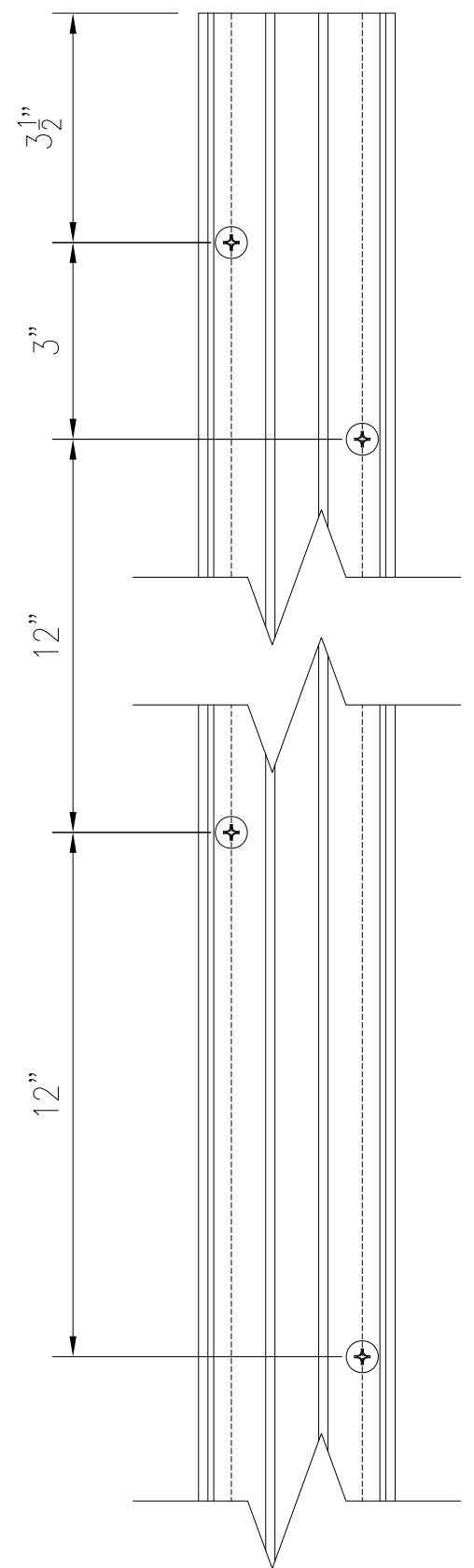

**JAMB ANCHOR LOCATIONS  
DETAIL**

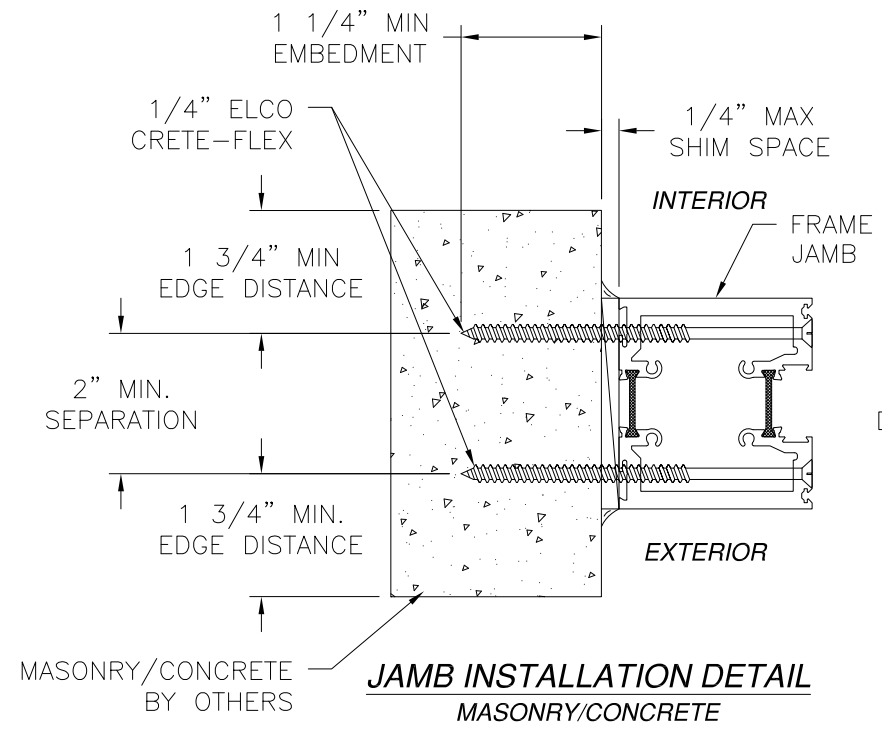

**JAMB INSTALLATION DETAIL  
MASONRY/CONCRETE**

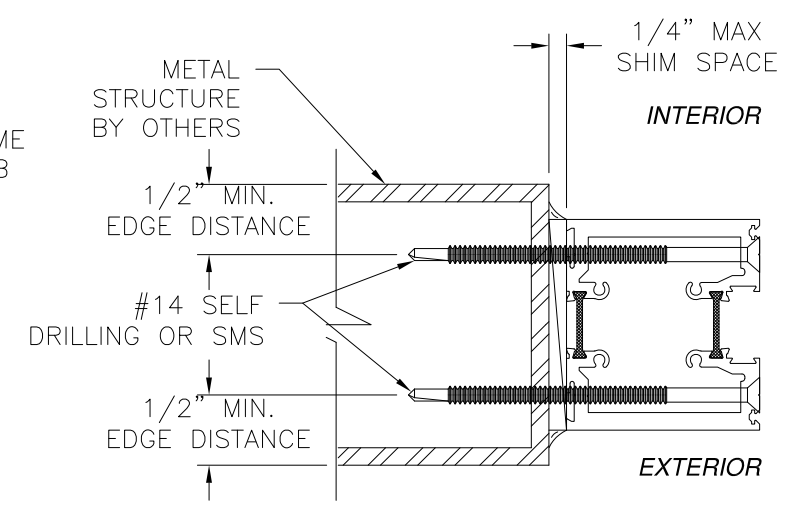

**JAMB INSTALLATION DETAIL  
METAL STRUCTURE**

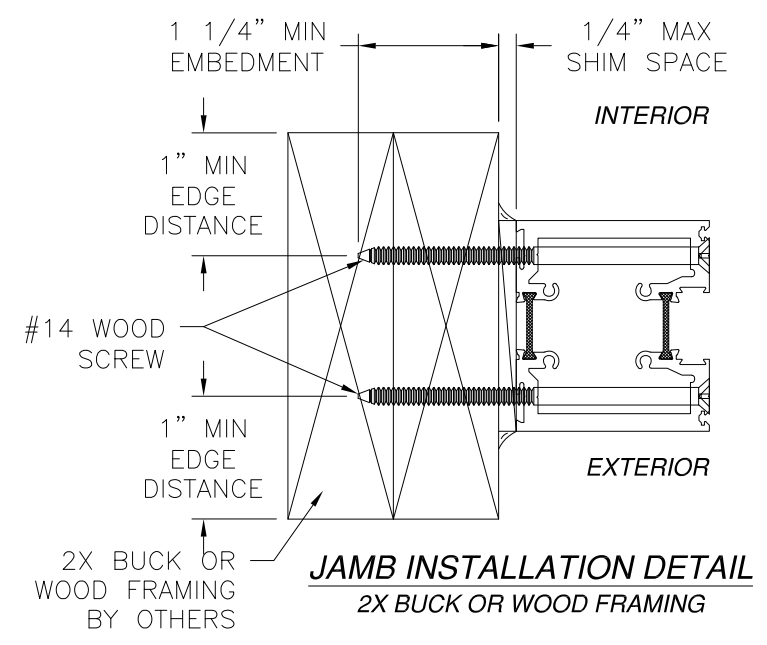

**JAMB INSTALLATION DETAIL  
2X BUCK OR WOOD FRAMING**

**NOTES:**  
INTERIOR AND EXTERIOR FINISHES, BY OTHERS, NOT SHOWN FOR CLARITY.

SIGNED: 04/27/2021

**SOLAR INNOVATIONS, INC.**  
31 ROBERTS RD.  
PINE GROVE, PA 17963

SI 33350 G3 IMPACT FGW 3.5' X 9.5' PANEL  
90° CORNER NO-POST - FLUSH SILL  
INSTALLATION DETAILS

DRAWN: N.G.	DWG NO. 08-02639	REV A
SCALE NTS	DATE 03/19/15	SHEET 8 OF 10

L. ROBERTO LOMAS P.E.  
1432 WOODFORD RD LEWISVILLE, NC 27023  
434-688-0609 rllomas@rlomaspe.com



Luis R. Lomas P.E.  
TX No.: 101889



REVISIONS			
REV	DESCRIPTION	DATE	APPROVED
A	REVISED PER NEW REQUIREMENTS	02/17/2020	R.L.

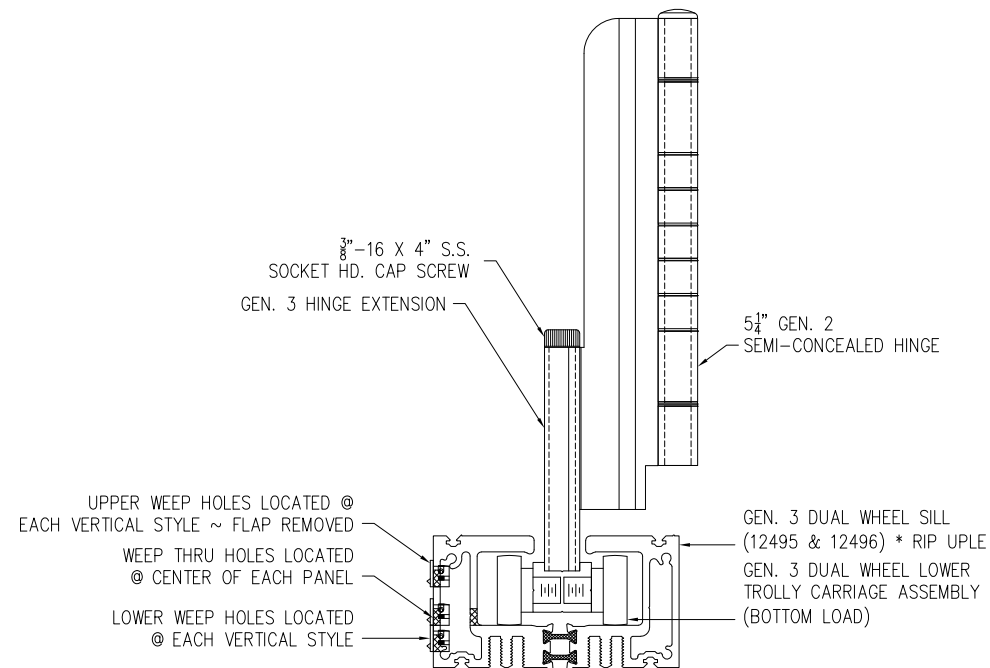
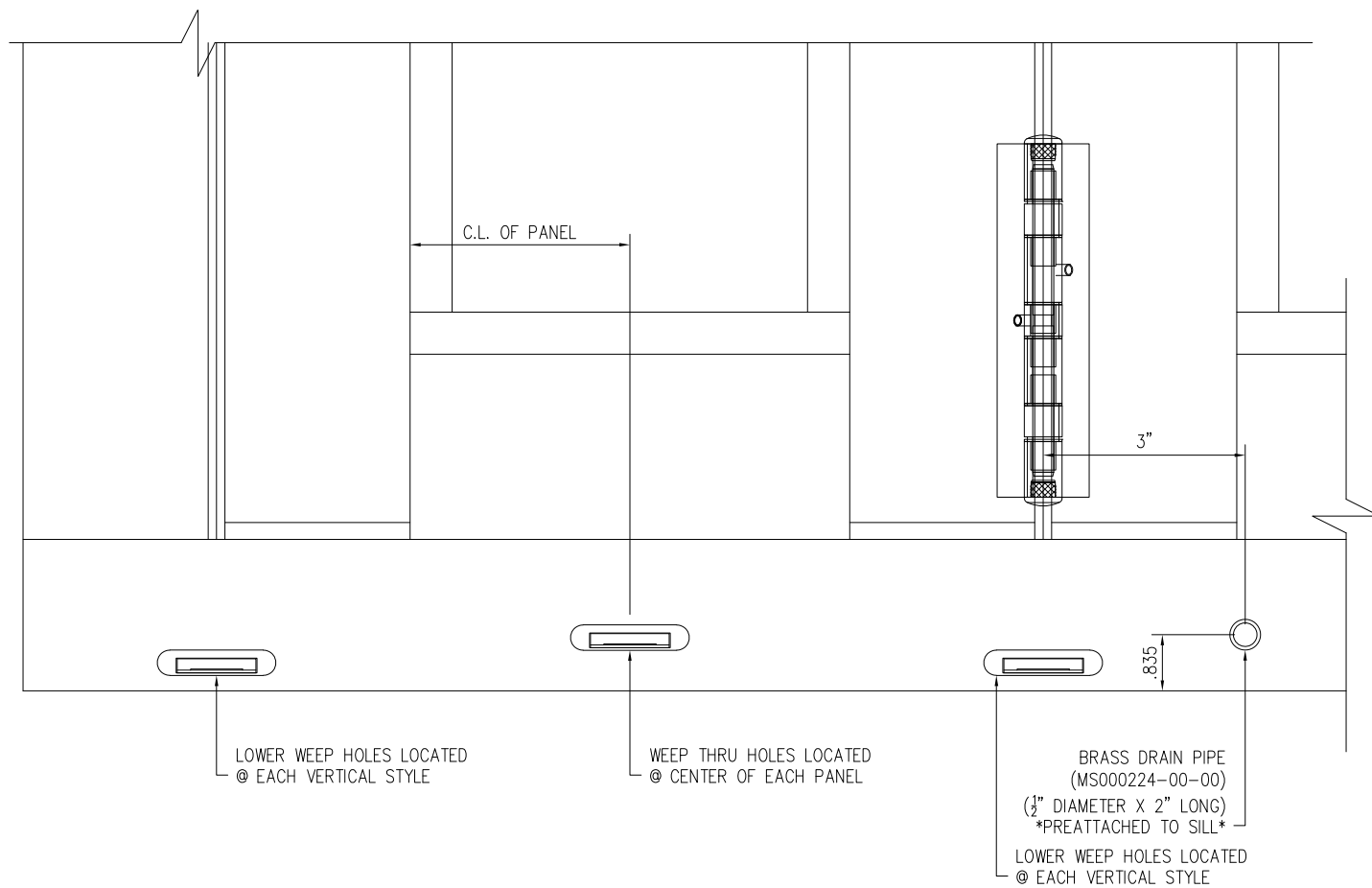

**WEEP HOLES LOCATION DETAILS**

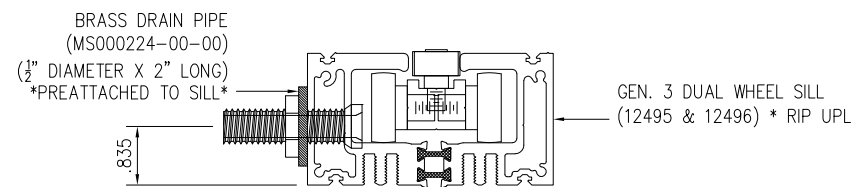

**DRAIN PIPE DETAIL**

SIGNED: 04/27/2021

SOLAR INNOVATIONS, INC.

31 ROBERTS RD.  
PINE GROVE, PA 17963

SI 33350 G3 IMPACT FGW 3.5' X 9.5' PANEL  
90° CORNER NO-POST - FLUSH SILL  
WEEP HOLES DETAILS

DRAWN: N.G.	DWG NO. 08-02639	REV A
SCALE NTS	DATE 03/19/15	SHEET 9 OF 10

L. ROBERTO LOMAS P.E.  
1432 WOODFORD RD LEWISVILLE, NC 27023  
434-688-0609 rllomas@rlomaspe.com

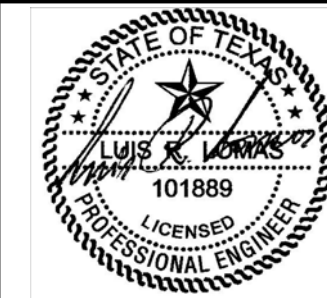

Luis R. Lomas P.E.  
TX No.: 101889

REVISIONS			
REV	DESCRIPTION	DATE	APPROVED
A	REVISED PER NEW REQUIREMENTS	02/17/2020	R.L.

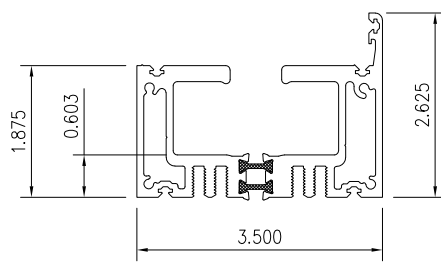

1 DUAL WHEEL HEAD / SILL

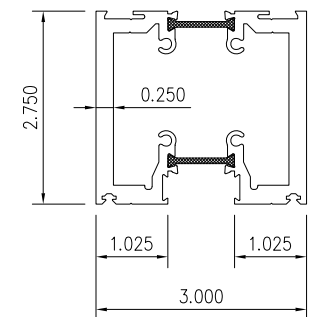

2 FRAME

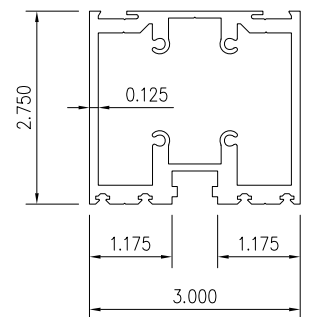

3 NON-THERMAL FRAME

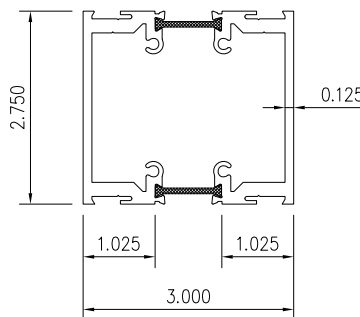

4 HORIZONTAL MULLION

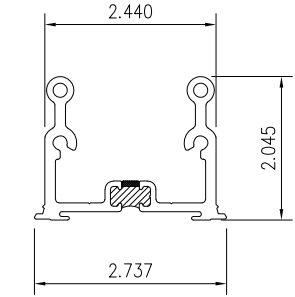

6 FRAME LUG

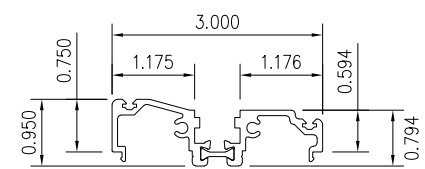

7 3rd GENERATION DOOR ADAPTOR

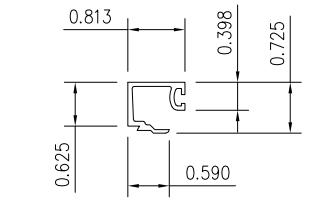

8 1/4" GLASS STOP

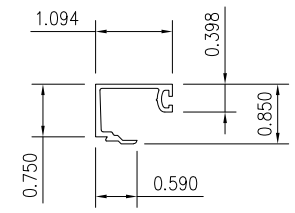

9 7/16" GLASS STOP

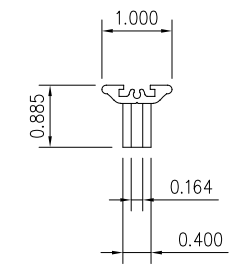

10 2nd GENERATION HANDLE

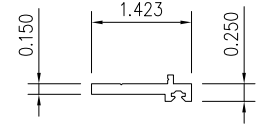

5 FRAME CAP

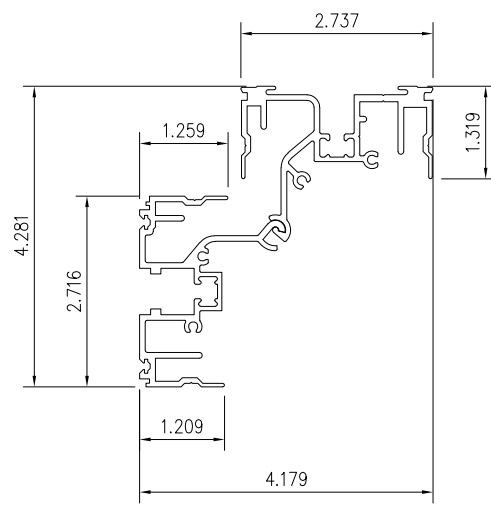

11 KNUCKLE JAMB

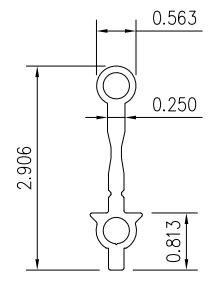

12 HINGE EXTENSION

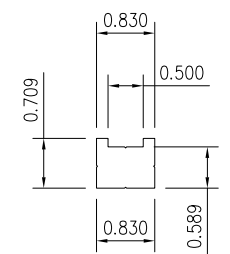

13 TROLLEY BODY

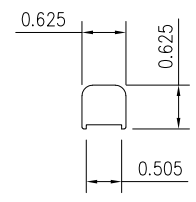

14 IDLER BODY

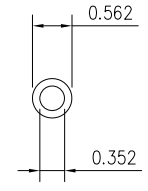

15 HINGE BARREL

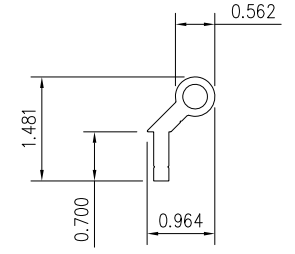

16 5 1/4" SEMI-CONCEALED HINGE

SIGNED: 04/27/2021

SOLAR INNOVATIONS, INC.  
 31 ROBERTS RD.  
 PINE GROVE, PA 17963

SI 33350 G3 IMPACT FGW 3.5' X 9.5' PANEL  
 90° CORNER NO-POST - FLUSH SILL  
 COMPONENTS

DRAWN: N.G.	DWG NO. 08-02639	REV A
SCALE NTS	DATE 03/19/15	SHEET 10 OF 10

L. ROBERTO LOMAS P.E.  
 1432 WOODFORD RD LEWISVILLE, NC 27023  
 434-688-0609 rllomas@lrlomaspe.com



Luis R. Lomas P.E.  
 TX No.: 101889