

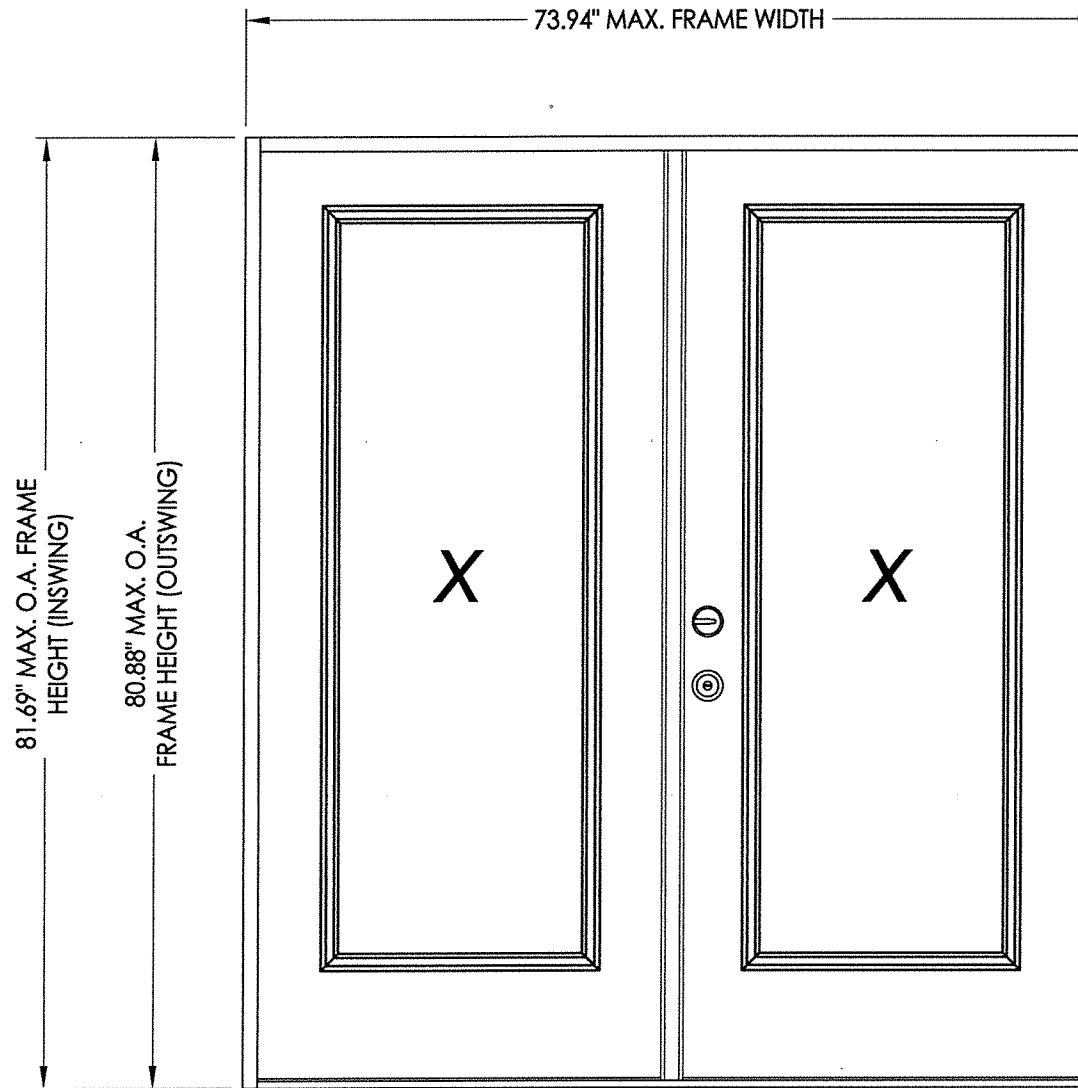

8811 West Market Street  
Colfax, NC 27235

# Glazed Steel Door

"NON-IMPACT"  
INSWING / OUTSWING



**EVALUATED FOR USE IN THE STATE OF TEXAS**

The Glazed Steel Door system described herein complies with the 2006 International Residential Code (IRC), Sections R301 & R613 and the 2006 International Building Code (IBC), Sections 1405.12, 1609, 1714.5, 2403 and 2404 (including Texas revisions) subject to the following conditions:

1. Anchors shall be as listed and spaced as shown in the details. Anchor embedment to base material shall be beyond wall dressing or stucco.
2. When used in areas requiring wind-borne debris protection this product is required to be protected with an impact resistant covering that complies with Section R301.2.1.2 of the IRC and Section 1609.1.2 of the IBC.
3. Allowable design pressure requirements must be equal to or less than the design pressure rating shown in the design pressure chart, sheet 1 of this drawing.
4. Conditions not covered by this drawing are subject to further engineering analysis.

TABLE OF CONTENTS	
SHEET#	DESCRIPTION
1	Typical elevations, design pressures & general notes
2	Astragal details (Ultimate Hurricane)
3	Door panel details (lip lite insert glazing)
4	Horizontal & vertical cross sections
5	Vertical cross sections
6	Frame anchoring

CONFIG.	MODEL	DESIGN PRESSURE (PSF)	
		POSITIVE	NEGATIVE
XX	INSWING	+30.0	-35.0
	OUTSWING	+30.0	-30.0

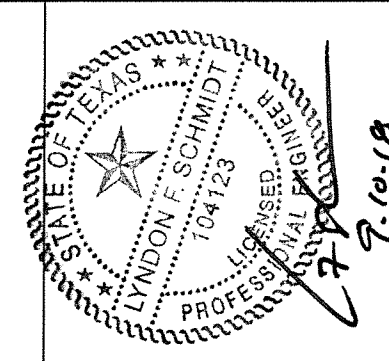

Documents Prepared By: Lyndon F. Schmidt, P.E.  
TEXAS P.E. #104123

**RW** BUILDING CONSULTANTS, INC.  
P.O. Box 230 Vairico FL 33595  
Phone No.: 813.659.9197

TEXAS BOARD OF PROFESSIONAL ENGINEERS  
CERTIFICATE OF REGISTRATION # F-11852

PRODUCT: ENDURA

PART OR ASSEMBLY: TYPICAL ELEVATION, DESIGN PRESSURES & GENERAL NOTES

NO.	DATE	BY	REVISIONS
3	8/28/18	LFS	ADDED ADDITIONAL THRESHOLDS
2	5/07/15	LFS	ADD. NEW ASTRAGAL PIN CAPTURE
1	1/09/14	LFS	ADDED ARTICULATING SILL

DATE: 9/06/12

SCALE: N.T.S.

DWG. BY: JK

CHK. BY: LFS

DRAWING NO.: TX-4220

SHEET 1 OF 6

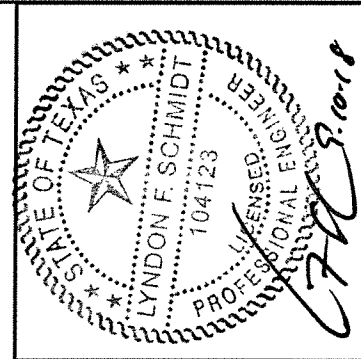
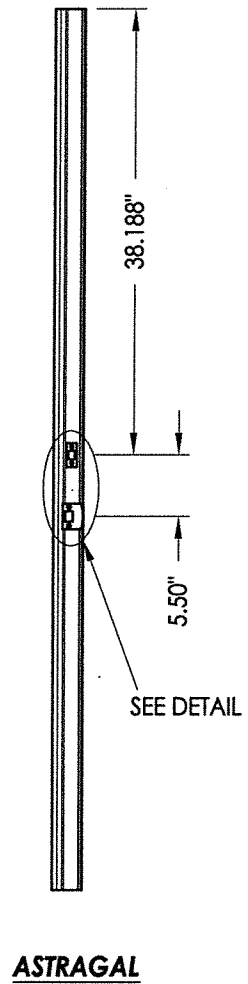
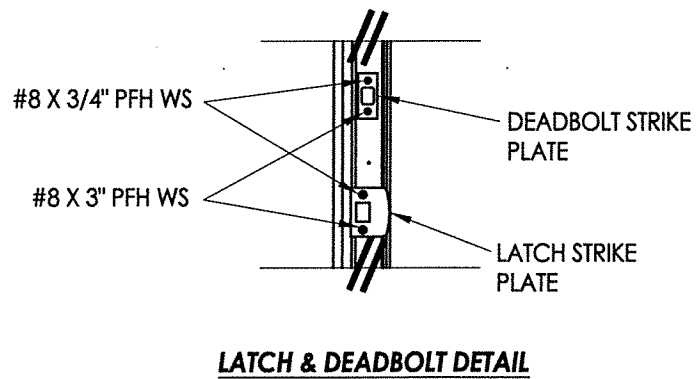
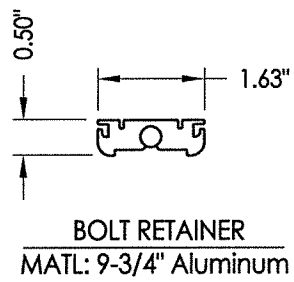
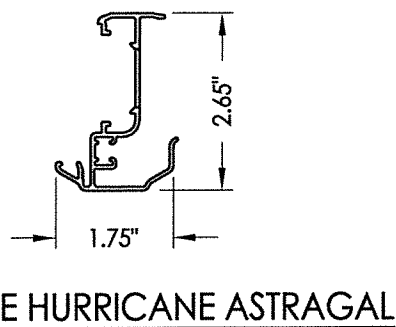
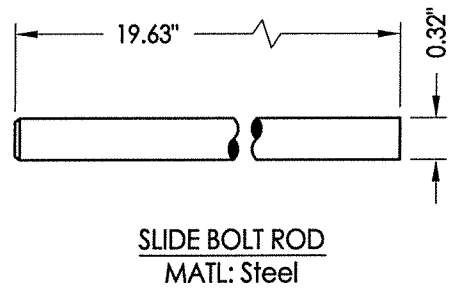
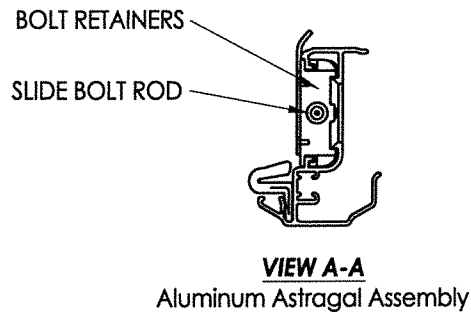
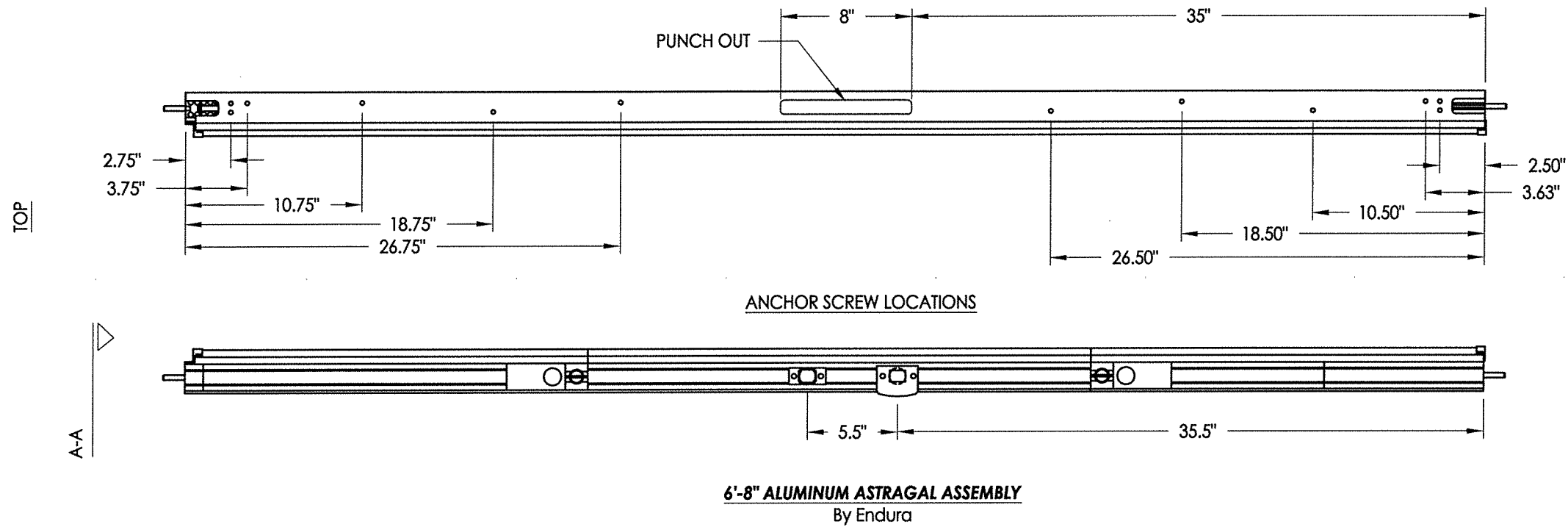

Documents Prepared By: Lyndon F. Schmidt, P.E.  
TEXAS P.E. #104123

**RW** BUILDING CONSULTANTS, INC.  
P.O. Box 230 Valrico FL 33595  
Phone No.: 813.659.9197

TEXAS BOARD OF PROFESSIONAL ENGINEERS  
CERTIFICATE OF REGISTRATION # F-11852

PRODUCT: ENDURA

PART OR ASSEMBLY: ASTRAGAL DETAILS (ULTIMATE HURRICANE)

NO.	DATE	REVISIONS
3	8/28/18	ADDED ADDITIONAL THRESHOLDS LFS
2	5/07/15	ADD NEW ASTRAGAL PIN CAPTURE LFS
1	1/09/14	ADDED ARTICULATING SILL LFS
		BY

DATE: 9/06/12

SCALE: N.T.S.

DWG. BY: JK

CHK. BY: LFS

DRAWING NO.: TX-4220

SHEET 2 OF 6

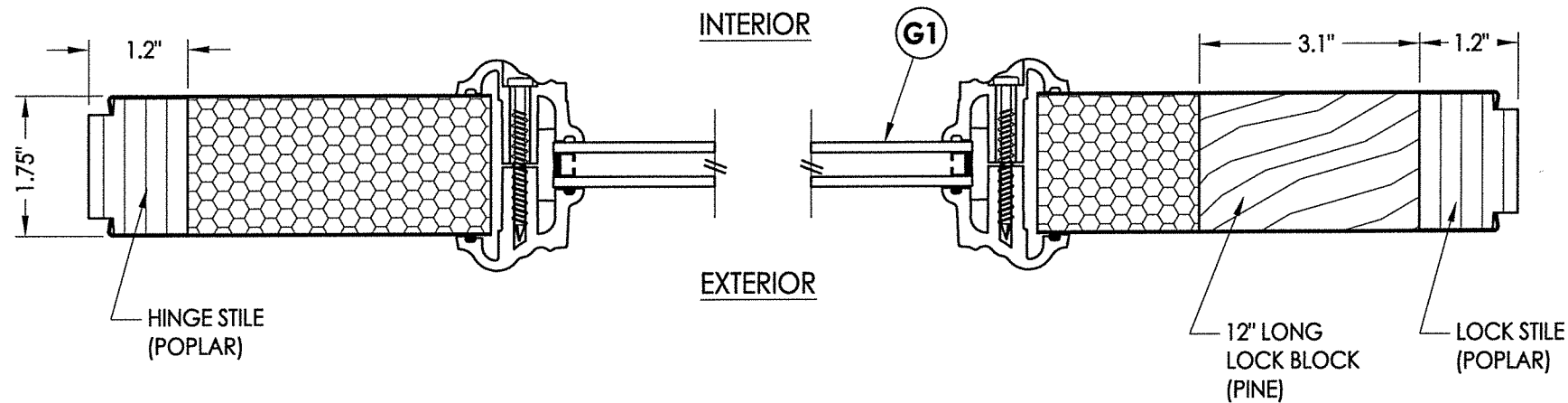

**1**  
**3** HORIZONTAL CROSS SECTION

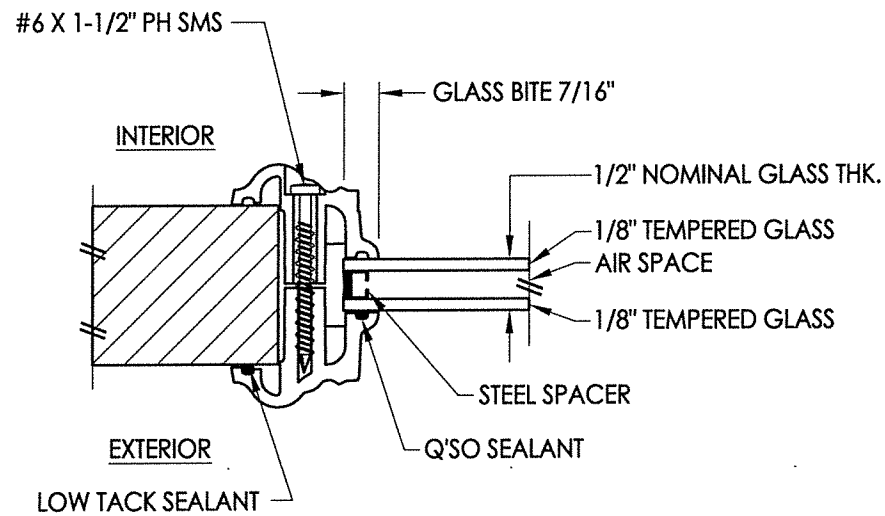
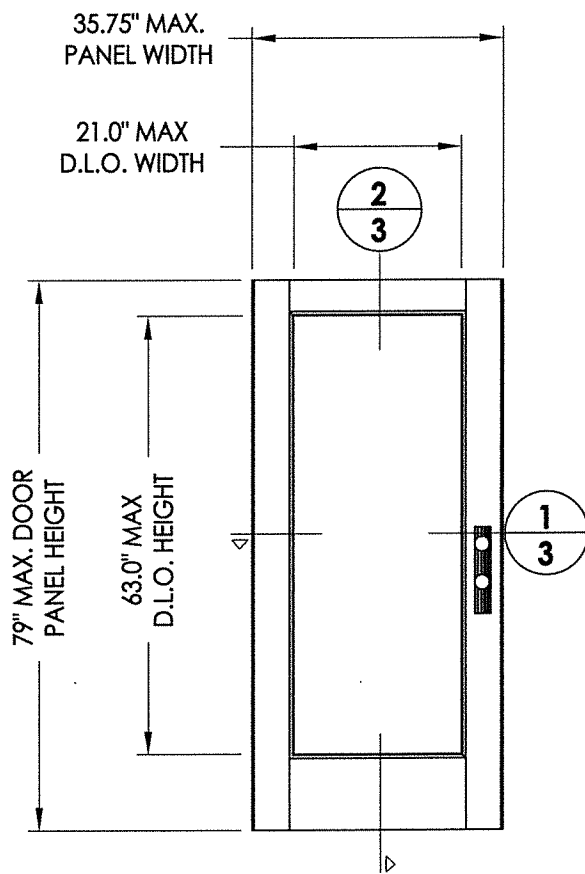

**G1** GLAZING DETAIL  
Lip Lite Insert Glazing (RSL)

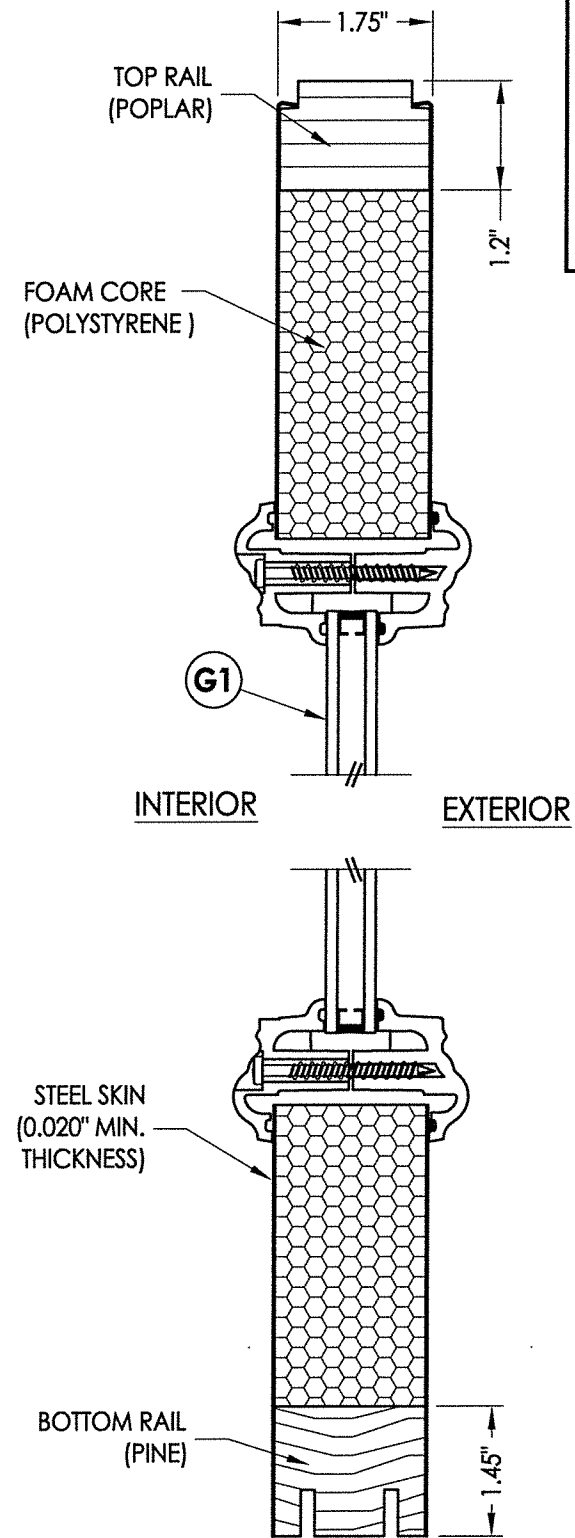

**2**  
**3** VERTICAL CROSS SECTION

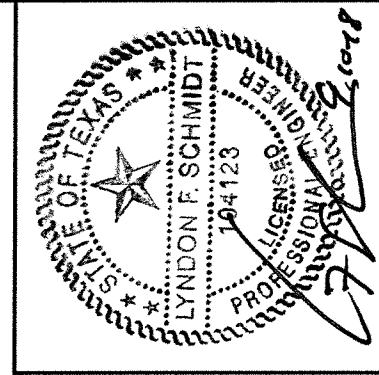

Documents Prepared By: Lyndon F. Schmidt, P.E.  
TEXAS P.E. #104123

**RW** BUILDING CONSULTANTS, INC.  
P.O. Box 230 Valrico FL 33595  
Phone No.: 813.659.9197  
TEXAS BOARD OF PROFESSIONAL ENGINEERS  
CERTIFICATE OF REGISTRATION # F-11852

PRODUCT: ENDURA  
PART OR ASSEMBLY: DOOR PANEL DETAILS (LIP LITE INSERT GLAZING)

NO.	DATE	BY	REVISIONS
3	8/28/18	LFS	ADDED ADDITIONAL THRESHOLDS
2	5/07/15	LFS	ADD NEW ASTRAGAL PIN CAPTURE
1	1/09/14	LFS	ADDED ARTICULATING SILL

DATE: 9/06/12  
SCALE: N.T.S.  
DWG. BY: JK  
CHK. BY: LFS  
DRAWING NO.: TX-4220  
SHEET 3 OF 6

R:\Clients\Endura PERMANENT\B - Texas Dept of Ins\TDI - 607\Drawings\2018 - REV 2\TX-4220.dwg, 1-4

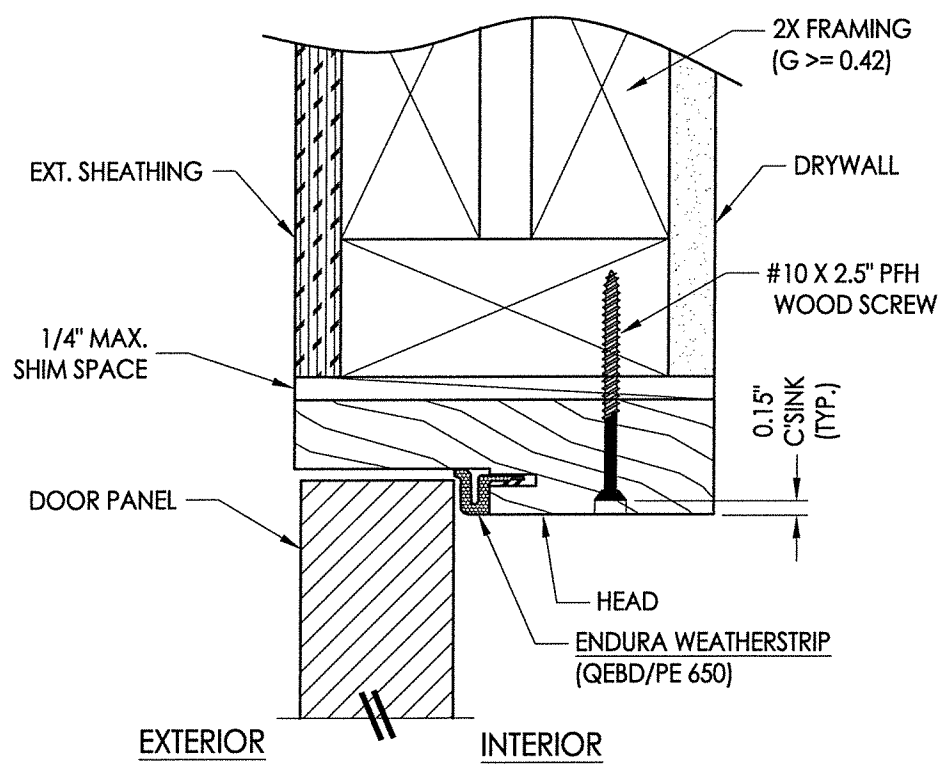
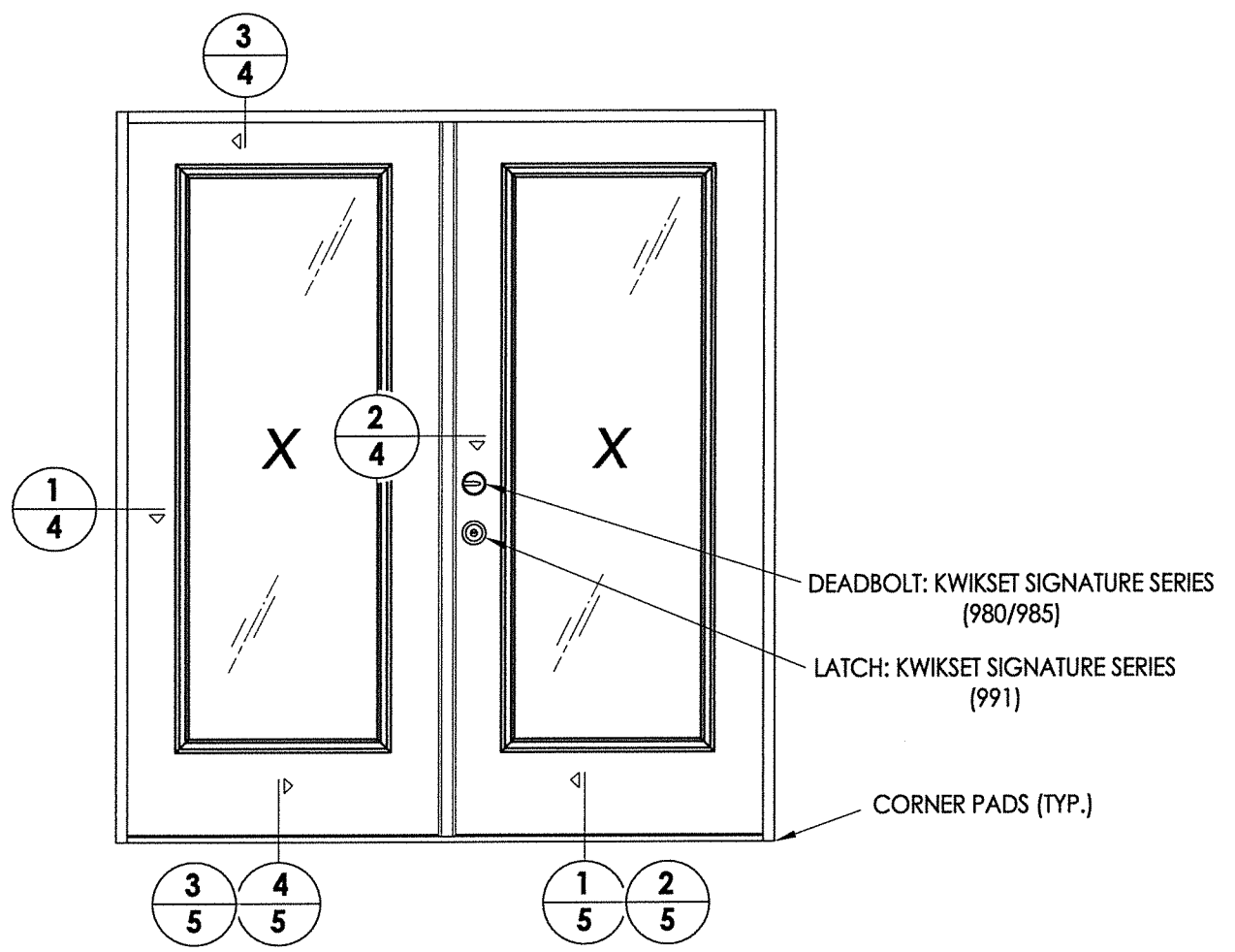

**3 VERTICAL CROSS SECTION**  
 4 Outswing shown - inswing also approved

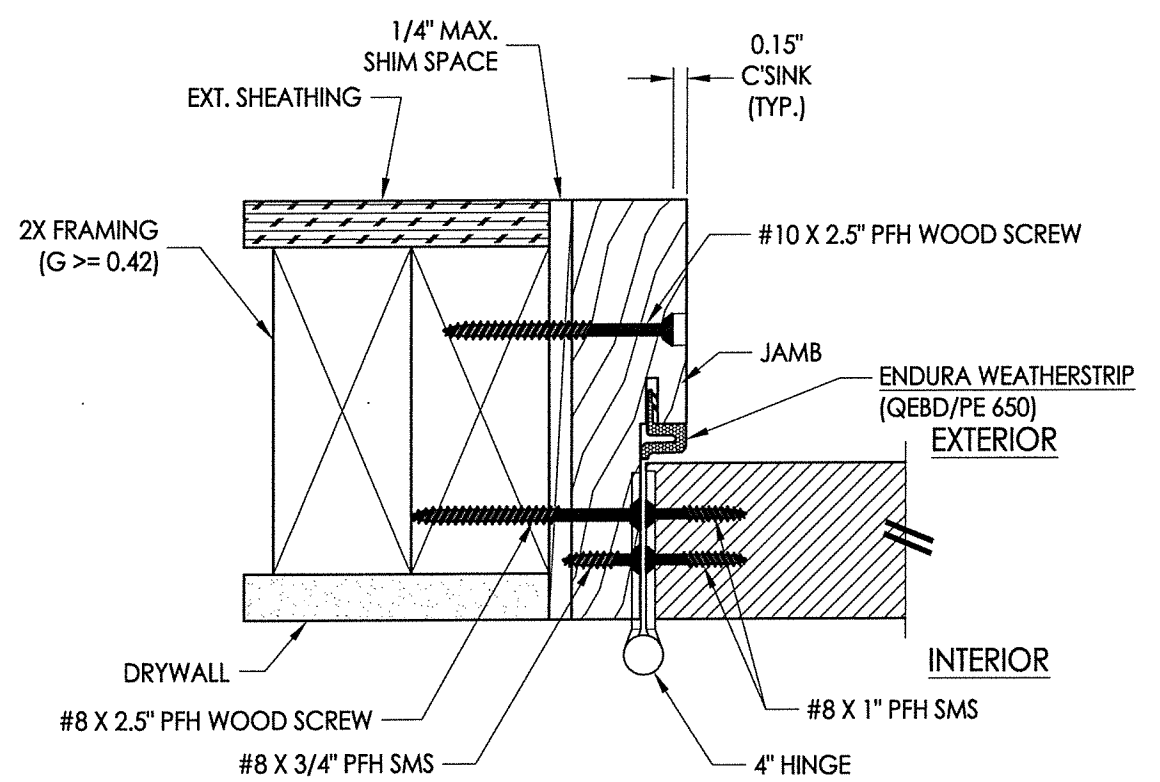

**1 HORIZONTAL CROSS SECTION**  
 4 Inswing shown - Outswing also approved

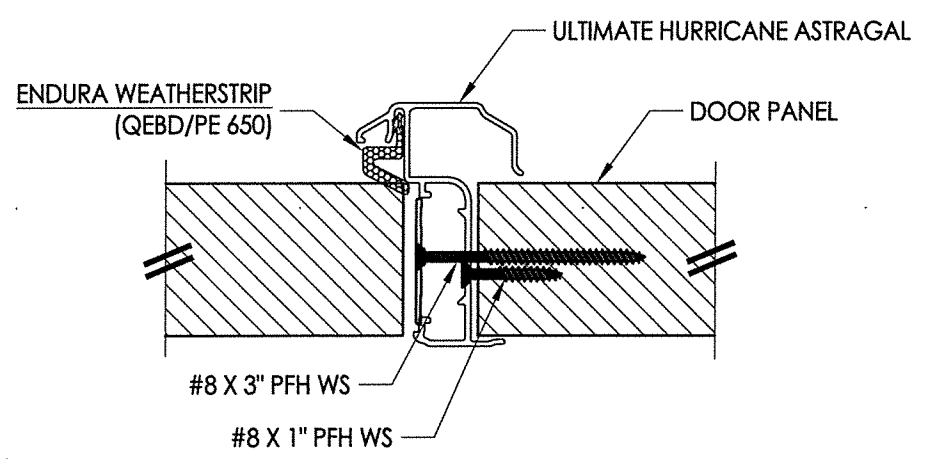

**2 HORIZONTAL CROSS SECTION**  
 4

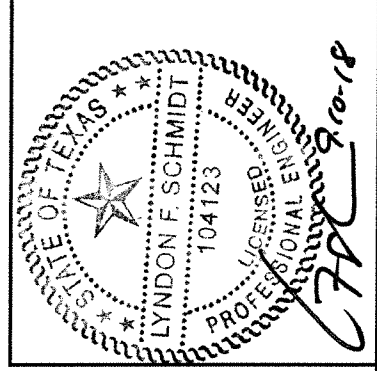

Documents Prepared By: Lyndon F. Schmidt, P.E.  
 TEXAS P.E. #104123

**RW** BUILDING CONSULTANTS, INC.  
 P.O. Box 230 Valrico FL, 33595  
 Phone No.: 813.659.9197

TEXAS BOARD OF PROFESSIONAL ENGINEERS  
 CERTIFICATE OF REGISTRATION # F-11852

PRODUCT:	ENDURA		
PART OR ASSEMBLY:	HORIZONTAL & VERTICAL CROSS SECTIONS		
NO.	DATE	BY	REVISIONS
3	8/28/18	LFS	ADDED ADDITIONAL THRESHOLDS
2	5/07/15	LFS	ADD NEW ASTRAGAL PIN CAPTURE
1	1/09/14	LFS	ADDED ARTICULATING SILL

DATE: 9/06/12  
 SCALE: N.T.S.  
 DWG. BY: JK  
 CHK. BY: LFS  
 DRAWING NO.: TX-4220  
 SHEET 4 OF 6

R:\Clients\Endura PERMANENT\B - Texas Dept of Ins\TDI - 607\Drawings\2018 - REV 2\TX-4220.dwg, 1-5

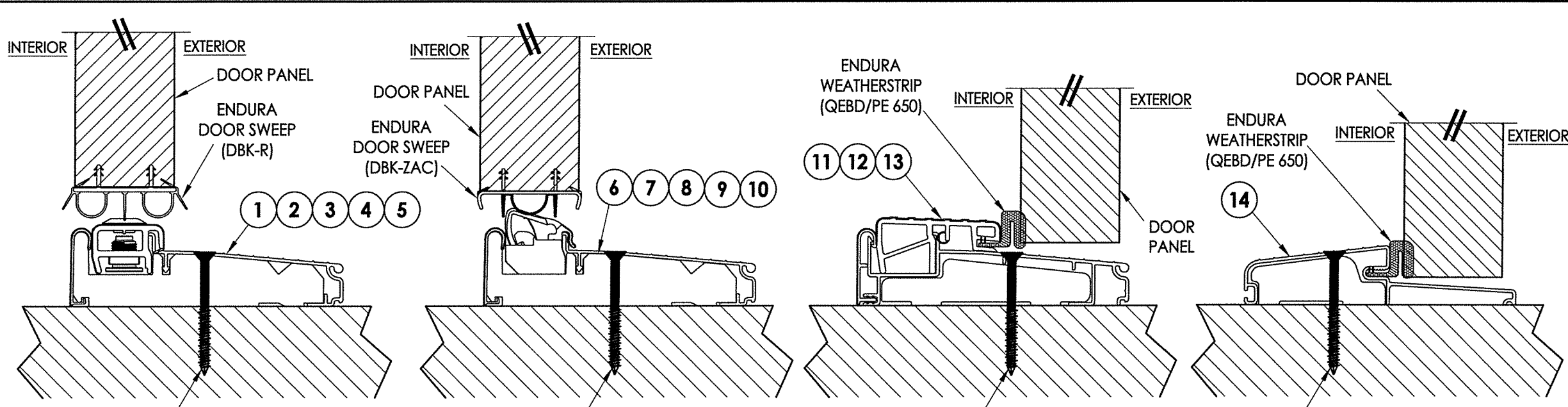

#10 X 2.5" PFH WOOD SCREW OR 1/4" X 2-3/4" ELCO OR ITW CONCRETE SCREW

**1 VERTICAL CROSS SECTION**  
5 Inswing Adjustable Threshold

**2 VERTICAL CROSS SECTION**  
5 Inswing Articulating Threshold w/ Pin Capture

**3 VERTICAL CROSS SECTION**  
5 Outswing Bump Threshold

**4 VERTICAL CROSS SECTION**  
5 Outswing Bump Threshold

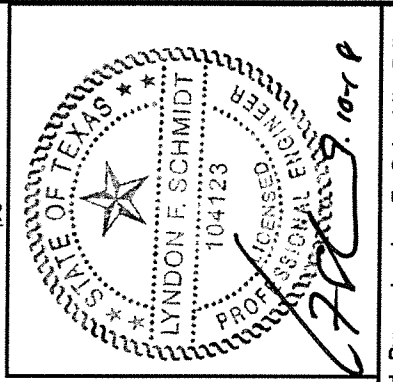
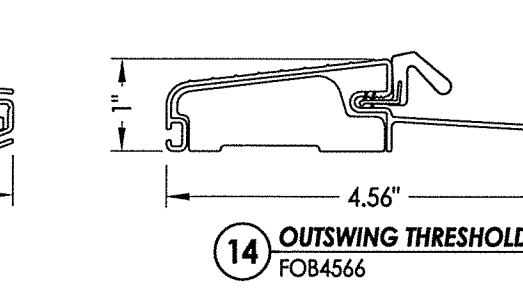
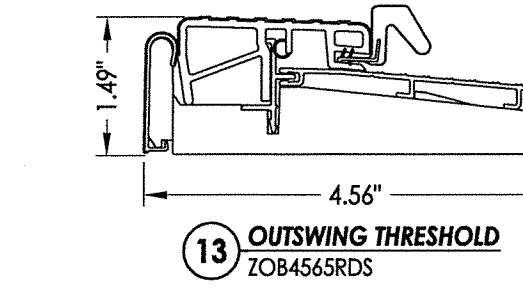
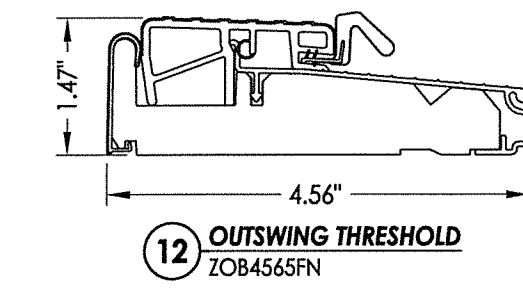
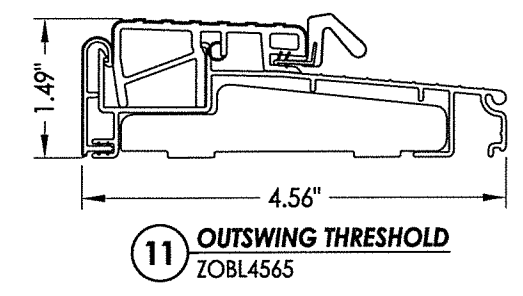
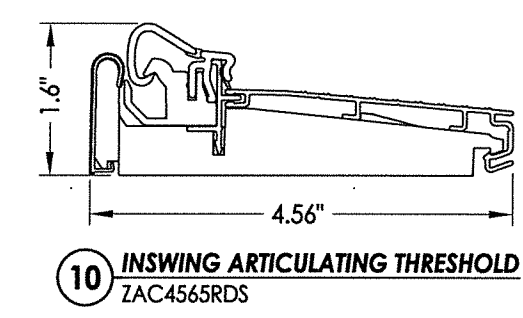
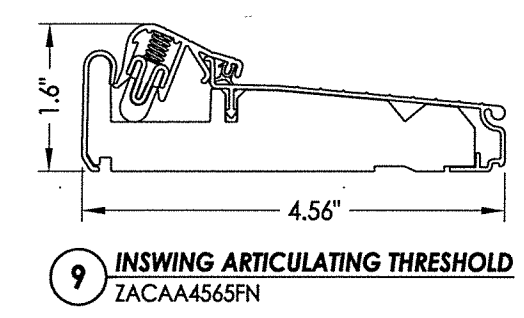
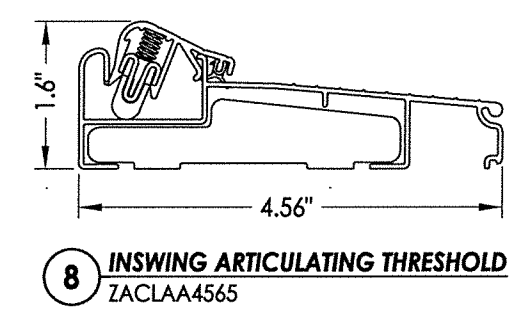
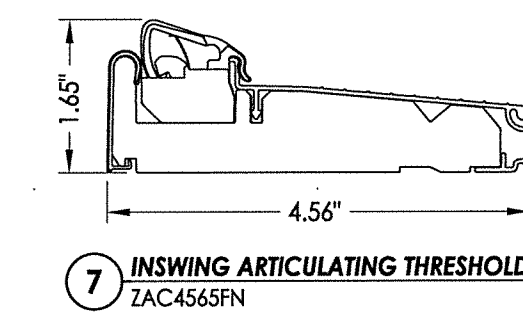
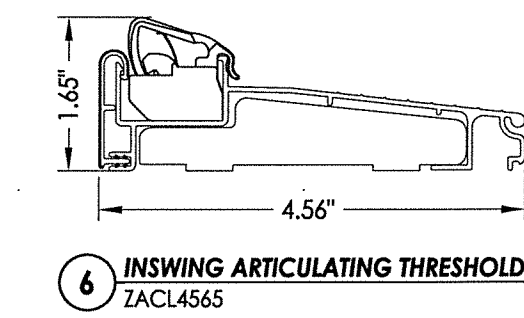
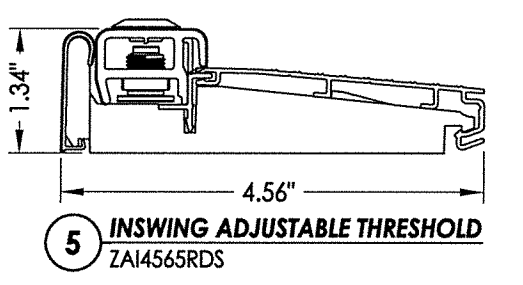
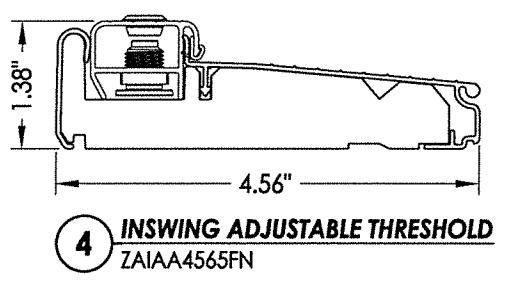
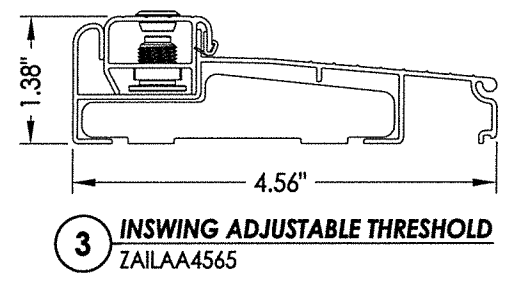
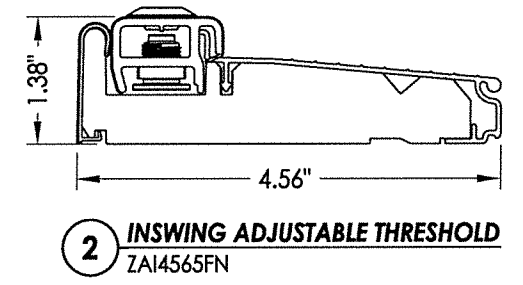
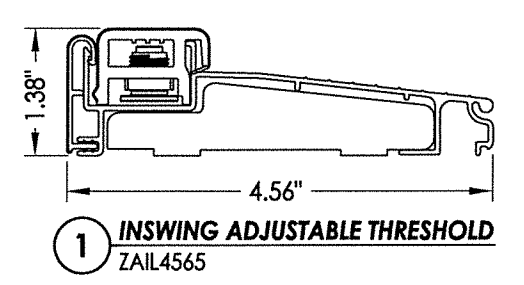

Documents Prepared By: Lyndon F. Schmidt, P.E.  
TEXAS P.E. #104123

**RW** BUILDING CONSULTANTS, INC.  
P.O. Box 230 Valrico FL 33585  
Phone No.: 813.659.9197

TEXAS BOARD OF PROFESSIONAL ENGINEERS  
CERTIFICATE OF REGISTRATION # F-11852

PRODUCT: ENDURA		PART OR ASSEMBLY: VERTICAL CROSS SECTIONS	
NO.	DATE	BY	REVISIONS
3	8/28/18	LFS	ADDED ADDITIONAL THRESHOLDS
2	5/07/15	LFS	ADD NEW ASTRAGAL PIN CAPTURE
1	1/09/14	LFS	ADDED ARTICULATING SILL
DATE: 9/06/12			
SCALE: N.T.S.			
DWG. BY: JK			
CHK. BY: LFS			
DRAWING NO.: TX-4220			
SHEET 5 OF 6			

© 2012 R.W. BUILDING CONSULTANTS INC.

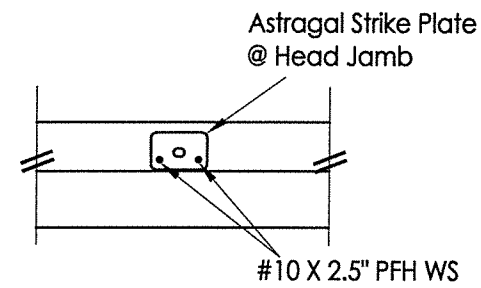
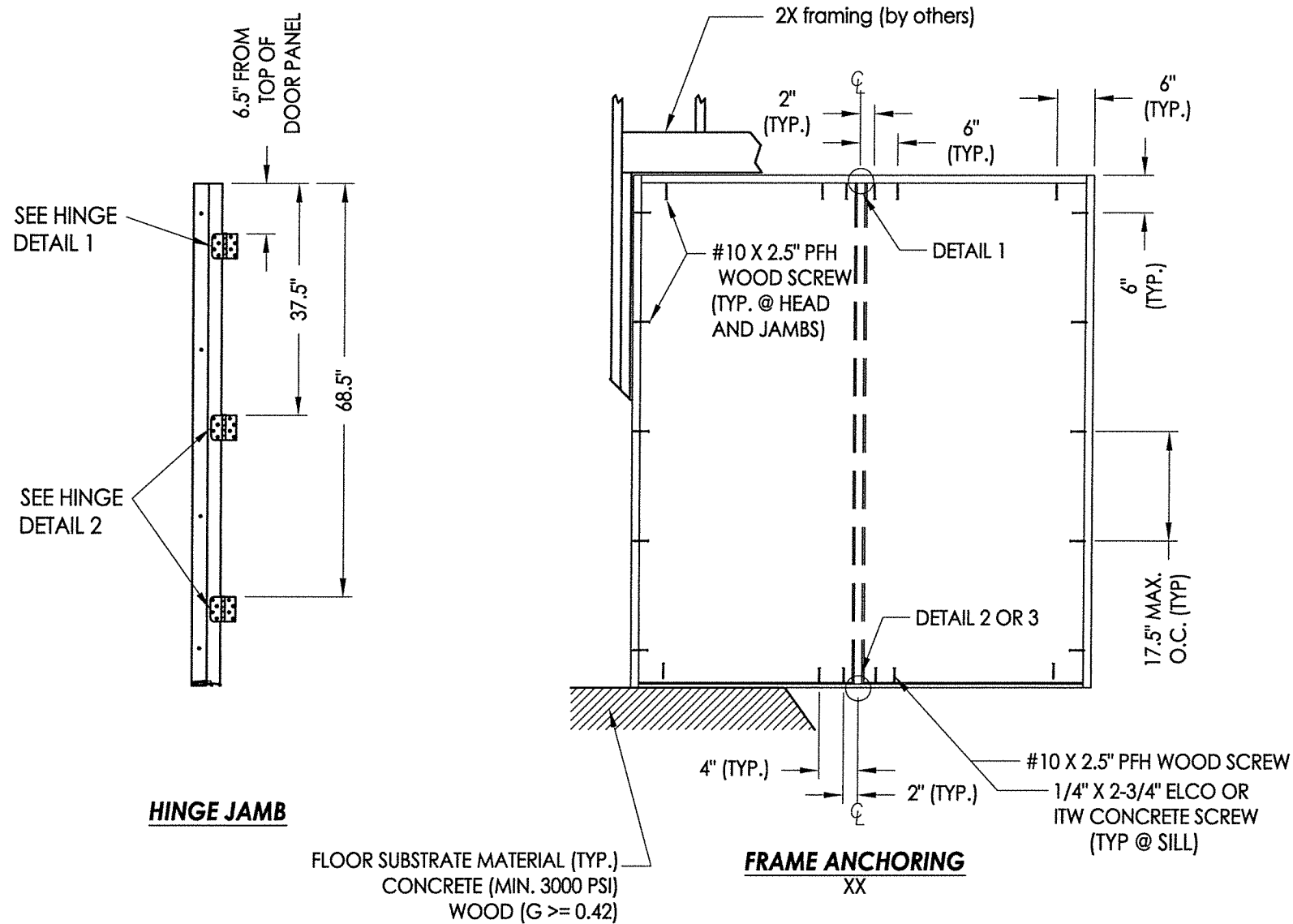

**DETAIL 1**

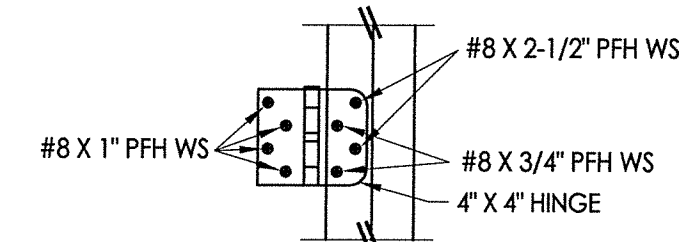

**HINGE DETAIL 1**

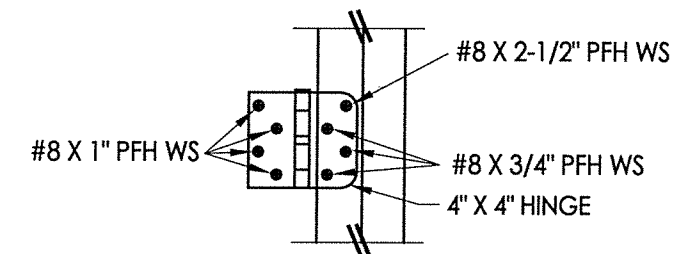

**HINGE DETAIL 2**

**CONCRETE ANCHOR NOTES:**

1. Concrete anchor locations at the corners may be adjusted to maintain the min. edge distance to mortar joints.
2. Concrete anchor locations noted as "MAX. ON CENTER" must be adjusted to maintain the min. edge distance to mortar joints, additional concrete anchors may be required to ensure the "MAX. ON CENTER" dimension are not exceeded.
3. Concrete anchor table:

ANCHOR TYPE	ANCHOR SIZE	MIN. EMBEDMENT	MIN. CLEARANCE TO MASONRY EDGE	MIN. CLEARANCE TO ADJACENT ANCHOR
ITW TAPCON®	1/4"	1-3/4"	2-1/2"	3"
ELCO ULTRACON®	1/4"	1-3/4"	1"	3"

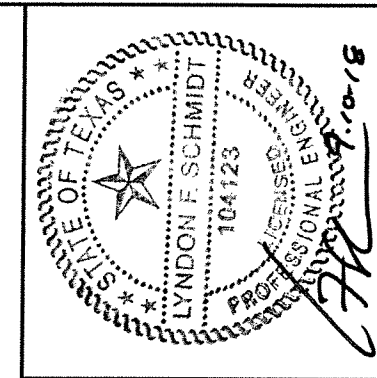
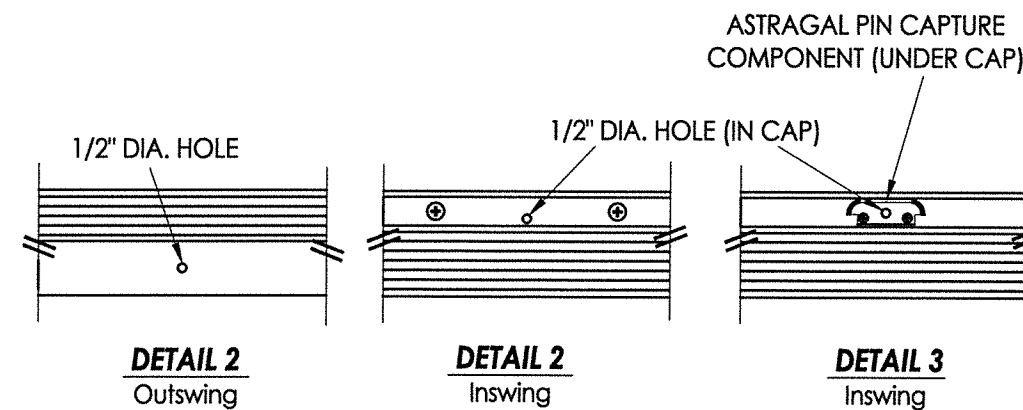

Documents Prepared By: Lyndon F. Schmidt, P.E.  
TEXAS P.E. #104123

**RW** BUILDING CONSULTANTS, INC.  
P.O. Box 230 Valrico FL 33595  
Phone No.: 813.659.9197

TEXAS BOARD OF PROFESSIONAL ENGINEERS  
CERTIFICATE OF REGISTRATION # F-11852

PRODUCT:	ENDURA	
PART OR ASSEMBLY:	FRAME ANCHORING	
NO.	DATE	BY
3	8/28/18	LFS
2	5/07/15	LFS
1	1/09/14	LFS
REVISIONS		
DATE:	9/06/12	
SCALE:	N.T.S.	
DWG. BY:	JK	
CHK. BY:	LFS	
DRAWING NO.:	TX-4220	
SHEET	6	OF 6