



PLYCO CORPORATION

P.O. BOX 386
500 INDUSTRIAL RD.
ELKHART LAKE, WI 53020
PH: (920) 876-3611 FAX: (920) 876-3527

PLYCO CORPORATION

SERIES 20EV FLUSH STEEL INSWING DOOR (NON-IMPACT)

INSTALLATION NOTES:

- ONE (1) INSTALLATION ANCHOR IS REQUIRED AT EACH ANCHOR LOCATION SHOWN UNLESS OTHERWISE NOTED.
- THE NUMBER OF INSTALLATION ANCHORS DEPICTED IS THE MINIMUM NUMBER OF ANCHORS TO BE USED FOR PRODUCT INSTALLATION.
- INSTALL INDIVIDUAL INSTALLATION ANCHORS WITHIN A TOLERANCE OF ±1/2 INCH OF THE DEPICTED LOCATION IN THE ANCHOR LAYOUT DETAIL (I.E., WITHOUT CONSIDERATION OF TOLERANCES). TOLERANCES ARE NOT CUMULATIVE FROM ONE INSTALLATION ANCHOR TO THE NEXT.
- SHIM AS REQUIRED AT EACH INSTALLATION ANCHOR WITH LOAD BEARING SHIM(S). MAXIMUM ALLOWABLE SHIM STACK TO BE 1/4 INCH. SHIM WHERE SPACE OF 1/16 INCH OR GREATER OCCURS. SHIM(S) SHALL BE CONSTRUCTED OF HIGH DENSITY PLASTIC OR BETTER.
- FOR INSTALLATION INTO WOOD FRAMING USE **#14 WOOD SCREWS** OF SUFFICIENT LENGTH TO ACHIEVE 1 1/2 INCH MINIMUM EMBEDMENT INTO WOOD SUBSTRATE.
- FOR INSTALLATION THROUGH 1X BUCK TO CONCRETE/MASONRY, OR DIRECTLY INTO CONCRETE/MASONRY, USE **1/4 INCH DIAMETER ITW TAPCONS** OF SUFFICIENT LENGTH TO ACHIEVE 1 1/4 INCH MINIMUM EMBEDMENT.
- FOR INSTALLATION INTO STEEL STUD FRAME USE **#14 GR. 5 SELF-TAPPING SCREWS** OF SUFFICIENT LENGTH TO ACHIEVE A MINIMUM 3 THREADS PENETRATION BEYOND STEEL STRUCTURE.
- FOR INSTALLATION ANCHORS THROUGH HINGES ONLY USE **#12 WOOD SCREWS, 3/16 INCH DIAMETER ITW TAPCONS, OR #12 SELF-TAPPING SCREWS** THROUGH EACH OF THE 3 HINGES ADHERING TO EMBEDMENT & EDGE DISTANCE REQUIREMENTS LISTED IN NOTES 5-7 ABOVE. USE ADDITIONAL **#14 WOOD SCREWS, 1/4 INCH DIAMETER ITW TAPCONS, OR #14 SELF-TAPPING SCREWS** THROUGH THE FRAME.
- MINIMUM EMBEDMENT AND EDGE DISTANCE EXCLUDE WALL FINISHES, INCLUDING BUT NOT LIMITED TO STUCCO, FOAM, BRICK VENEER, AND SIDING.
- INSTALLATION ANCHORS AND ASSOCIATED HARDWARE MUST BE MADE OF CORROSION RESISTANT MATERIAL OR HAVE A CORROSION RESISTANT COATING.
- FOR HOLLOW BLOCK AND GROUT FILLED BLOCK, DO NOT INSTALL INSTALLATION ANCHORS INTO MORTAR JOINTS. EDGE DISTANCE IS MEASURED FROM FREE EDGE OF BLOCK OR EDGE OF MORTAR JOINT INTO FACE SHELL OF BLOCK.
- INSTALLATION ANCHORS SHALL BE INSTALLED IN ACCORDANCE WITH ANCHOR MANUFACTURER'S INSTALLATION INSTRUCTIONS, AND ANCHORS SHALL NOT BE USED IN SUBSTRATES WITH STRENGTHS LESS THAN THE MINIMUM STRENGTH SPECIFIED BY THE ANCHOR MANUFACTURER.
- INSTALLATION ANCHOR CAPACITIES FOR PRODUCTS HEREIN ARE BASED ON SUBSTRATE MATERIALS WITH THE FOLLOWING PROPERTIES:
 - WOOD - MINIMUM SPECIFIC GRAVITY OF 0.42.
 - CONCRETE - MINIMUM COMPRESSIVE STRENGTH OF 3000 PSI.
 - MASONRY - STRENGTH CONFORMANCE TO ASTM C-90.
 - STEEL - MINIMUM YIELD STRENGTH OF 33 KSI. MINIMUM WALL THICKNESS OF 48 MILS (18 GAUGE).

GENERAL NOTES:

- THE PRODUCT SHOWN HEREIN IS DESIGNED AND MANUFACTURED TO COMPLY WITH THE 2018 INTERNATIONAL BUILDING CODE (IBC) AND 2018 INTERNATIONAL RESIDENTIAL CODE (IRC) AND HAS BEEN EVALUATED ACCORDING TO THE FOLLOWING:
 - ASTM E330-14
- ADEQUACY OF THE EXISTING STRUCTURAL CONCRETE/MASONRY AND 2X FRAMING AS A MAIN WIND FORCE RESISTING SYSTEM CAPABLE OF WITHSTANDING AND TRANSFERRING APPLIED PRODUCT LOADS TO THE FOUNDATION IS THE RESPONSIBILITY OF THE ENGINEER OR ARCHITECT OF RECORD FOR THE PROJECT OF INSTALLATION.
- 1X AND 2X BUCKS (WHEN USED) SHALL BE DESIGNED AND ANCHORED TO PROPERLY TRANSFER ALL LOADS TO THE STRUCTURE. BUCK DESIGN AND INSTALLATION IS THE RESPONSIBILITY OF THE ENGINEER OR ARCHITECT OF RECORD FOR THE PROJECT OF INSTALLATION.
- THE INSTALLATION DETAILS DESCRIBED HEREIN ARE GENERIC AND MAY NOT REFLECT ACTUAL CONDITIONS FOR A SPECIFIC SITE. IF SITE CONDITIONS CAUSE INSTALLATION TO DEVIATE FROM THE REQUIREMENTS DETAILED HEREIN, A LICENSED ENGINEER OR ARCHITECT SHALL PREPARE SITE SPECIFIC DOCUMENTS FOR USE WITH THIS DOCUMENT.
- APPROVED IMPACT PROTECTIVE SYSTEM **IS REQUIRED** ON THIS PRODUCT IN AREAS REQUIRING IMPACT RESISTANCE.
- FRAME MATERIAL: ALUMINUM 6063-T5 & CS-B STEEL
- DISSIMILAR METALS INCLUDING FASTENERS THAT MAY COME INTO CONTACT WITH ALUMINUM UNIT FRAMING SHALL BE PROTECTED.
- ALL EXPOSED STEEL COMPONENTS ARE GALVANIZED AND SHOP PRIMED.

TABLE OF CONTENTS	
SHEET	SHEET DESCRIPTION
1	INSTALLATION & GENERAL NOTES
2	ELEVATION & ANCHOR LAYOUT
3	VERTICAL SECTIONS
4	HORIZONTAL SECTIONS
5	COMPONENTS & BILL OF MATERIALS

DESIGN PRESSURE RATING				
LOCK TYPE	FRAME SIZE	DESIGN PRESSURE		MISSILE IMPACT RATING
SINGLE POINT	51.88" X 85.38"	+45.0 / -45.0 PSF *	W/O WATER INFILTRATION	NON-IMPACT
SINGLE POINT W/ DEAD BOLT	51.75" X 85.38"	+60.0 / -65.0 PSF *	W/O WATER INFILTRATION	NON-IMPACT

*UNIT SHALL BE INSTALLED AT LOCATION PROTECTED BY OVERHANG SUCH THE OVERHANG RATIO (OH) = OH LENGTH/OH HEIGHT GREATER THAN 1.0 WHERE WATER INFILTRATION IS REQUIRED.

TITLE: SERIES 20EV FLUSH STEEL INSWING DOOR (NON-IMPACT)

INSTALLATION & GENERAL NOTES

PREPARED BY:



BUILDING DROPS, INC.
398 E. DANIA BEACH BLVD., STE. 338
DANIA BEACH, FL 33004
PH: (954) 399-8478
FAX: (954) 744-4738
WEB: www.buildingdrops.com

REMARKS	BY	DATE

THE INSTALLATION DETAILS DESCRIBED HEREIN ARE GENERIC AND MAY NOT REFLECT ACTUAL CONDITIONS FOR A SPECIFIC SITE. IF SITE CONDITIONS CAUSE INSTALLATION TO DEVIATE FROM THE REQUIREMENTS DETAILED HEREIN, A LICENSED ENGINEER OR ARCHITECT SHALL PREPARE SITE SPECIFIC DOCUMENTS FOR USE WITH THIS DOCUMENT.



HERMES F. NORERO, P.E.
TEXAS P.E. No. 118471
BUILDING DROPS, INC
398 E. DANIA BEACH BLVD., # 338
DANIA BEACH, FL 33004
TBPE FIRM No. 13734

DATE:	02.13.20	
DWG. BY:	MS	CHK. BY: HFN
SCALE:	NTS	
DWG. #:	PCO031	

SHEET: 1 OF 5

s:\projects\plyco corp\tdi-19-1128 -tdi-submittal-series 20ev and 95ev gld and opa doors\dwg\pc031\pc031.dwg 12/17/2020 6:42 PM

TITLE: SERIES 20EV FLUSH STEEL
INSWING DOOR (NON-IMPACT)

ELEVATION &
ANCHOR LAYOUT

PREPARED BY:
BUILDING DROPS, INC.
398 E. DANIA BEACH BLVD., STE. 338
DANIA BEACH, FL 33004
PH: (954) 399-8478
FAX: (954) 744-4738
WEB: www.buildingdrops.com



REMARKS	BY	DATE

THE INSTALLATION DETAILS DESCRIBED HEREIN ARE GENERIC AND MAY NOT REFLECT ACTUAL CONDITIONS FOR A SPECIFIC SITE. IF SITE CONDITIONS CAUSE INSTALLATION TO DEVIATE FROM THE REQUIREMENTS DETAILED HEREIN, A LICENSED ENGINEER OR ARCHITECT SHALL PREPARE SITE SPECIFIC DOCUMENTS FOR USE WITH THIS DOCUMENT.

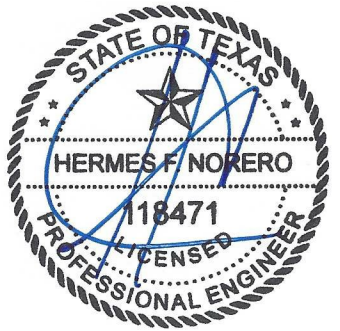

HERMES F. NORERO, P.E.
TEXAS P.E. No. 118471
BUILDING DROPS, INC
398 E. DANIA BEACH BLVD. # 338
DANIA BEACH, FL 33004
TBPE FIRM No. 13734

DATE: 02.13.20

DWG. BY: MS CHK. BY: HFN

SCALE: NTS

DWG. #: PCO031

SHEET:

2

OF 5

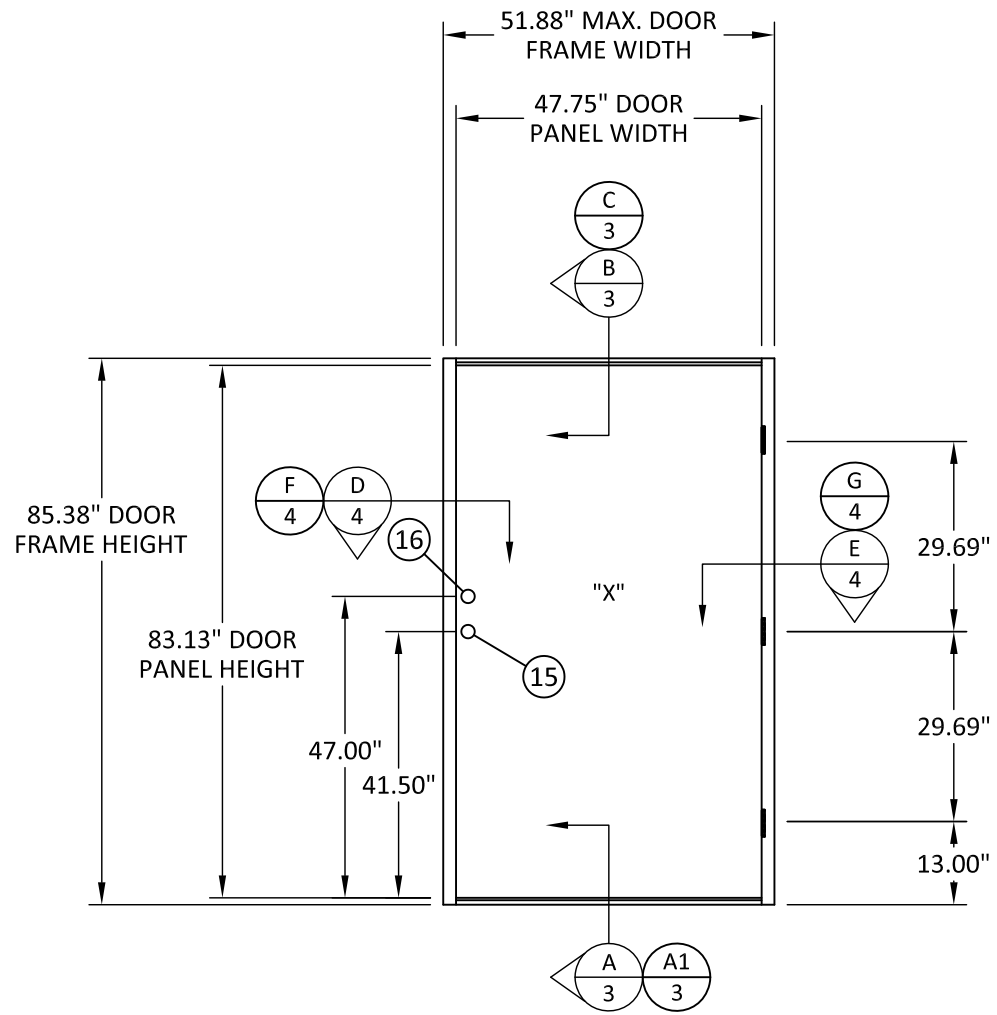

ELEVATION

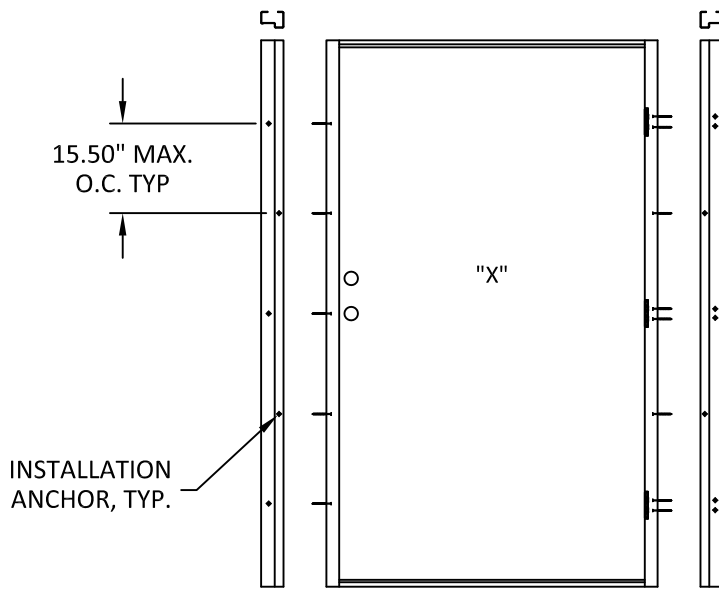

ANCHOR LAYOUT

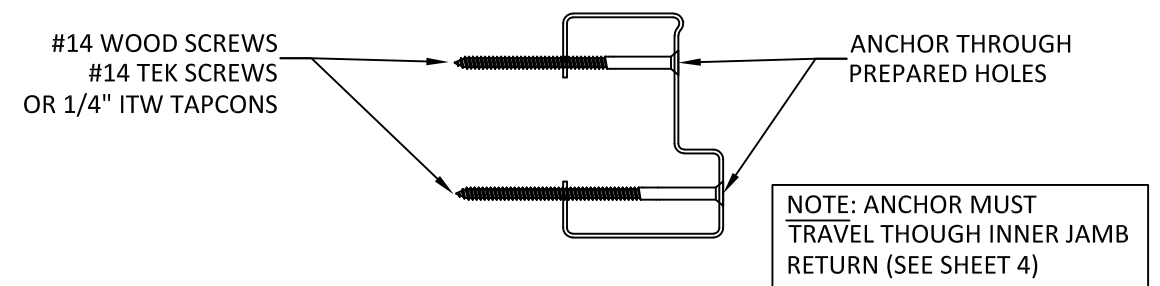

LOCK JAMB TYP. ANCHOR PLACEMENT

NOTE: ANCHOR MUST TRAVEL THROUGH INNER JAMB RETURN (SEE SHEET 4)

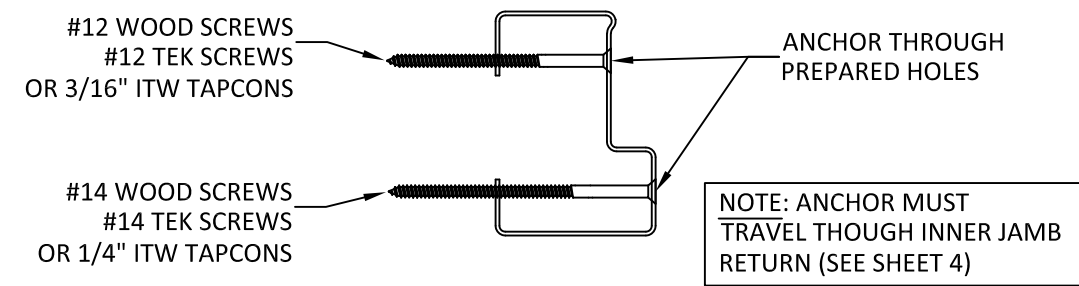

HINGE JAMB TYP. ANCHOR PLACEMENT

NOTE: ANCHOR MUST TRAVEL THROUGH INNER JAMB RETURN (SEE SHEET 4)

12/17/2020 6:42 PM
s:\projects\plyco corp\tdi-19-1128 -tdi submittal - series 20ev and 95ev glkd and opa doors\dwg\pco031.pco031.dwg

PLYCO

PLYCO CORPORATION

P.O. BOX 386
500 INDUSTRIAL RD.
ELKHART LAKE, WI 53020
PH: (920) 876-3611 FAX: (920) 876-3527

TITLE: SERIES 20EV FLUSH STEEL
INSWING DOOR (NON-IMPACT)

VERTICAL SECTIONS

PREPARED BY:
BUILDING DROPS, INC.

398 E. DANIA BEACH BLVD., STE. 338
DANIA BEACH, FL 33004
PH: (954) 399-8478
FAX: (954) 744-4738
WEB: www.buildingdrops.com



REMARKS	BY	DATE

THE INSTALLATION DETAILS DESCRIBED HEREIN ARE GENERIC AND MAY NOT REFLECT ACTUAL CONDITIONS FOR A SPECIFIC SITE. IF SITE CONDITIONS CAUSE INSTALLATION TO DEVIATE FROM THE REQUIREMENTS DETAILED HEREIN, A LICENSED ENGINEER OR ARCHITECT SHALL PREPARE SITE SPECIFIC DOCUMENTS FOR USE WITH THIS DOCUMENT.

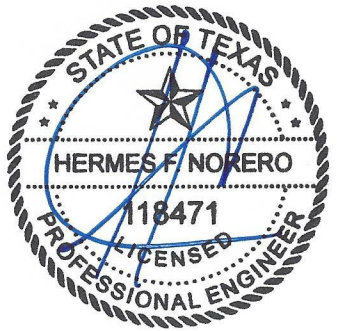

HERMES F. NORERO, P.E.
TEXAS P.E. No. 118471
BUILDING DROPS, INC
398 E. DANIA BEACH BLVD. # 338
DANIA BEACH, FL 33004
TBPE FIRM No. 13734

DATE: 02.13.20

DWG. BY: MS CHK. BY: HFN

SCALE: NTS

DWG. #: PCO031

SHEET:

3

OF 5

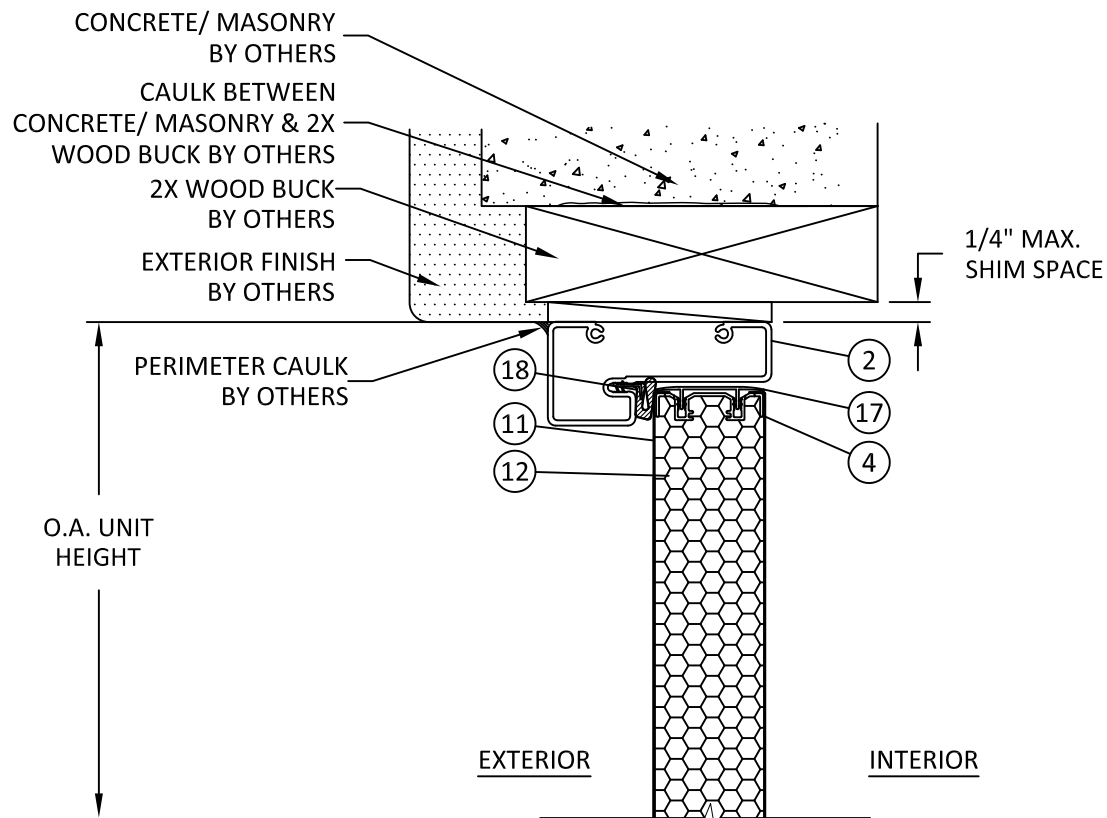

B
3 VERTICAL SECTION
HEAD - 2X WOOD BUCK

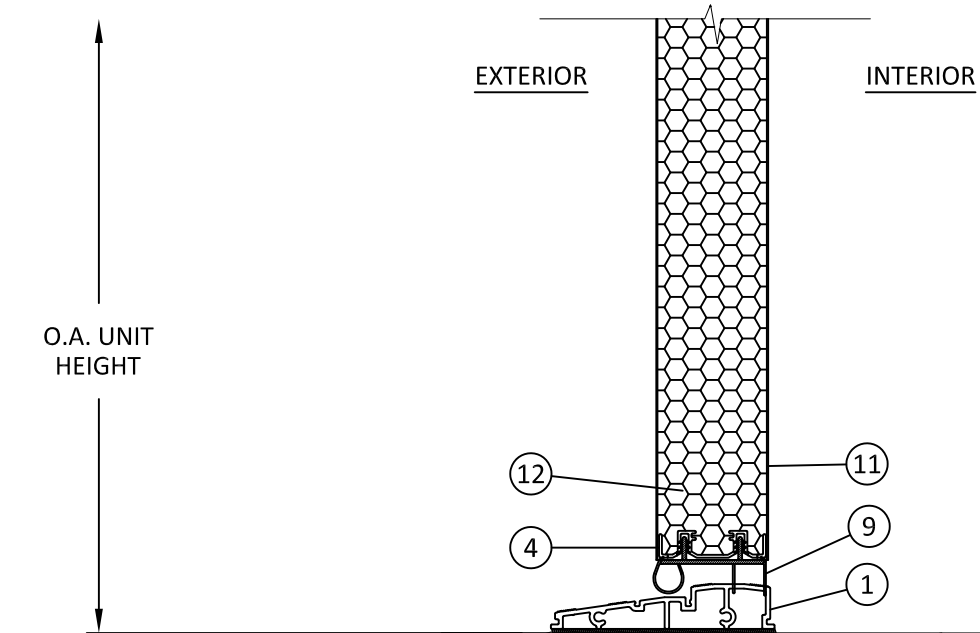

A
3 VERTICAL SECTION
SILL - CONCRETE/MASONRY

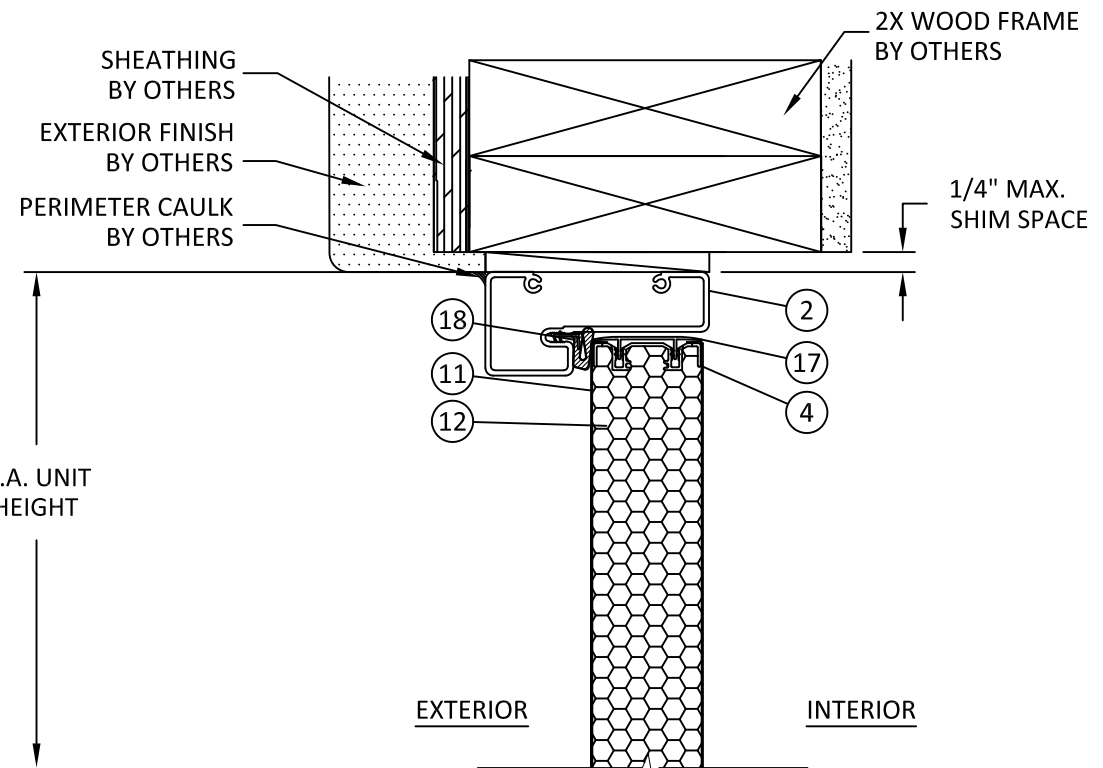

C
3 VERTICAL SECTION
HEAD - 2X WOOD FRAME

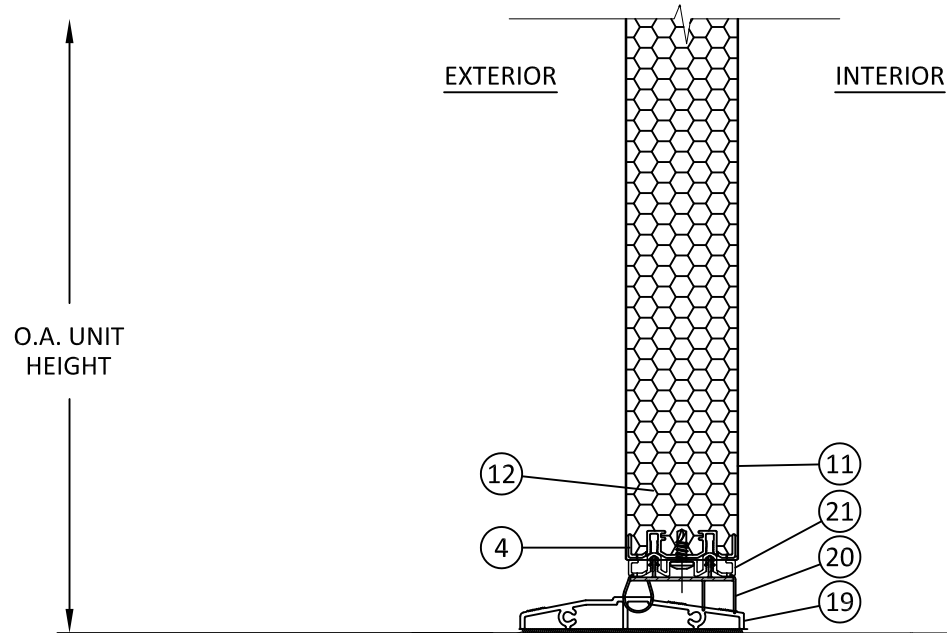

A1
3 VERTICAL SECTION
SILL - ADA THRESHOLD (OPTIONAL)

12/17/2020 6:42 PM

s:\projects\plyco corp\tdi-19-1128 -tdi submittal - series 20ev and 95ev gld and opa doors\dwg\pco031\pco031.dwg

TITLE: SERIES 20EV FLUSH STEEL
INSWING DOOR (NON-IMPACT)

HORIZONTAL SECTIONS

PREPARED BY:
BUILDING DROPS, INC.
398 E. DANIA BEACH BLVD., STE. 338
DANIA BEACH, FL 33004
PH: (954) 399-8478
FAX: (954) 744-4738
WEB: www.buildingdrops.com

REMARKS	BY	DATE

THE INSTALLATION DETAILS DESCRIBED HEREIN ARE GENERIC AND MAY NOT REFLECT ACTUAL CONDITIONS FOR A SPECIFIC SITE. IF SITE CONDITIONS CAUSE INSTALLATION TO DEVIATE FROM THE REQUIREMENTS DETAILED HEREIN, A LICENSED ENGINEER OR ARCHITECT SHALL PREPARE SITE SPECIFIC DOCUMENTS FOR USE WITH THIS DOCUMENT.

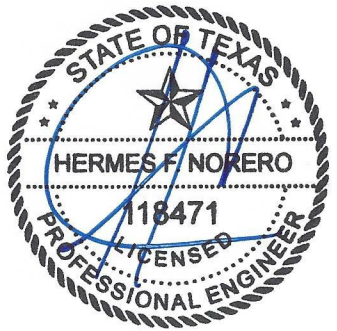

HERMES F. NORERO, P.E.
TEXAS P.E. No. 118471
BUILDING DROPS, INC
398 E. DANIA BEACH BLVD. # 338
DANIA BEACH, FL 33004
TBPE FIRM No. 13734

DATE: **02.13.20**

DWG. BY: **MS** CHK. BY: **HFN**

SCALE: **NTS**

DWG. #: **PCO031**

SHEET:

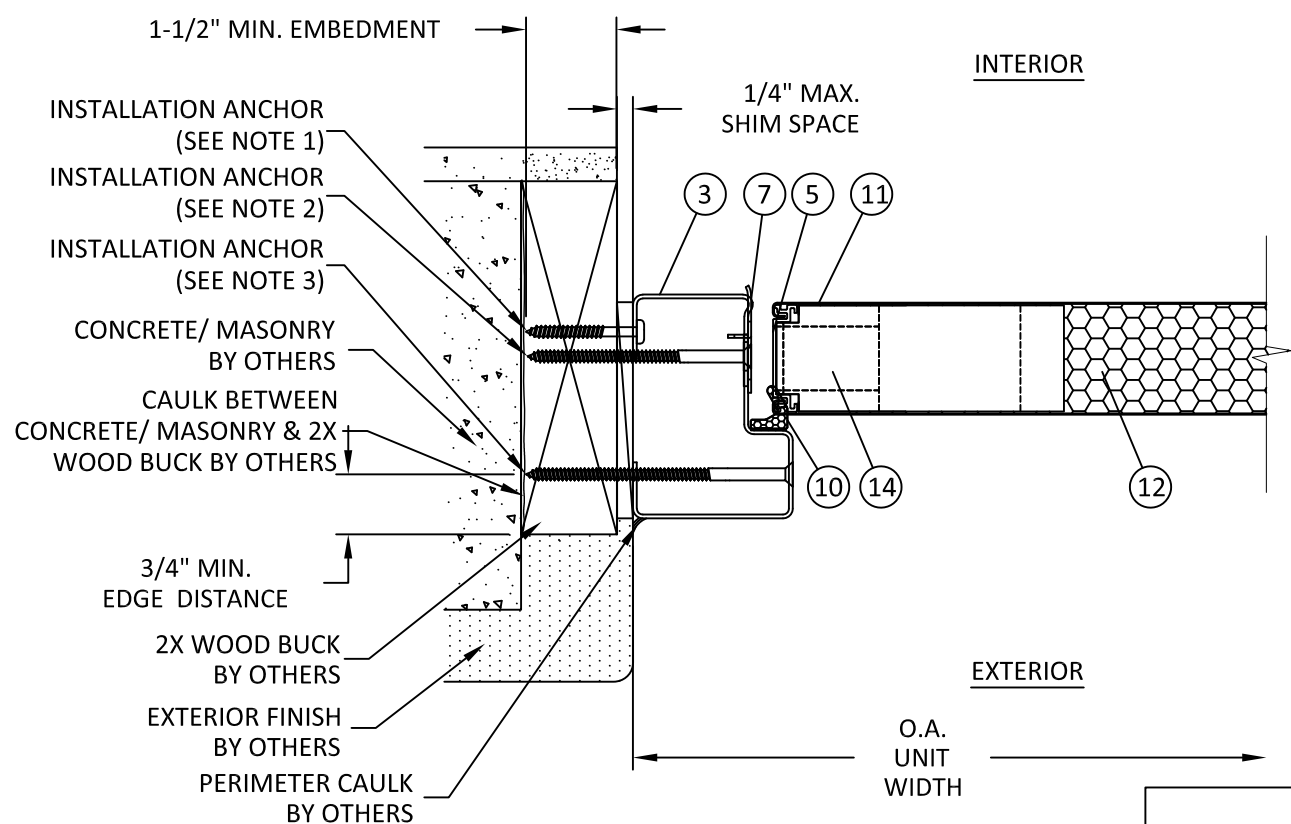

D
4 **HORIZONTAL SECTION**
JAMB - 2X WOOD BUCK, TYP.

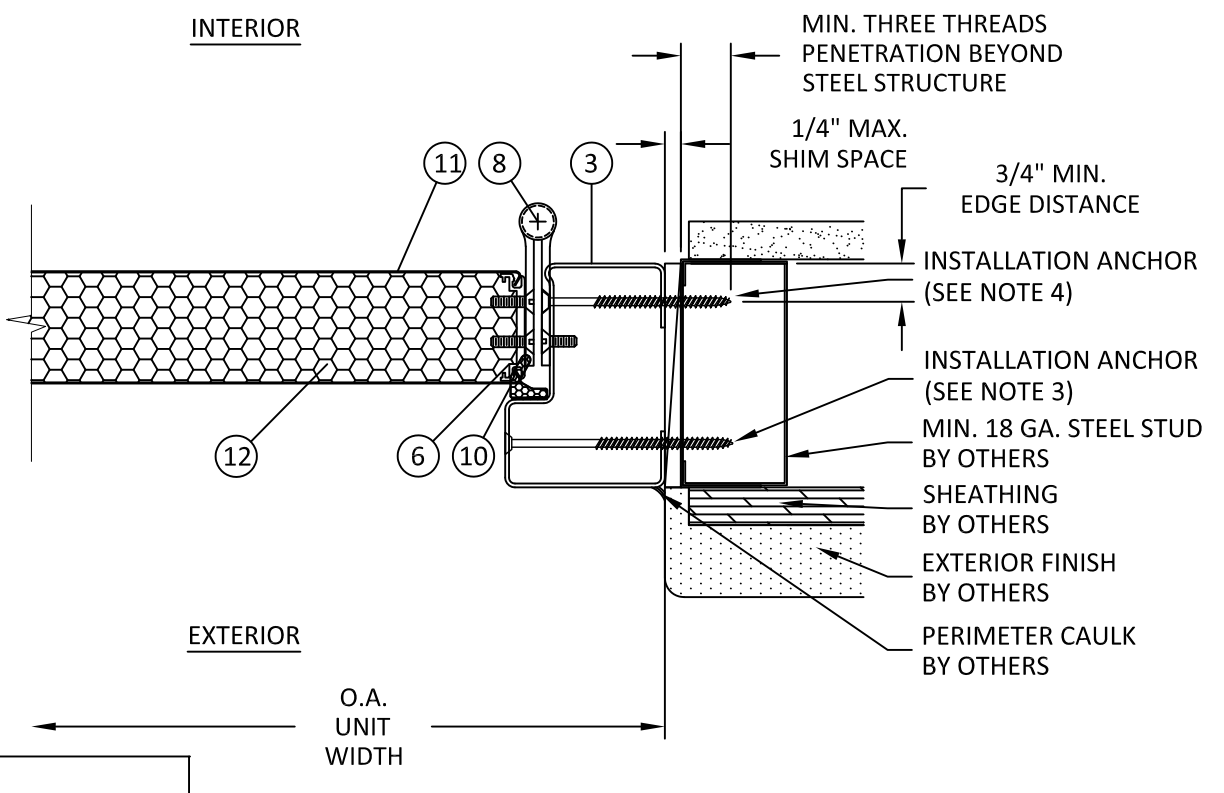

E
4 **HORIZONTAL SECTION**
JAMB - STEEL STUD, TYP.

INSTALLATION ANCHOR NOTES

1. ANCHOR THROUGH FRAME RETURN ANCHOR THROUGH STRIKE-SIDE FRAME
2. ANCHOR THROUGH MAIN FRAME ANCHOR THROUGH HINGE
3. ANCHOR THROUGH HINGE
4. SEE INSTALLATION NOTES ON SHEET 1 FOR APPLICABLE ANCHOR TYPES & SUBSTRATES.

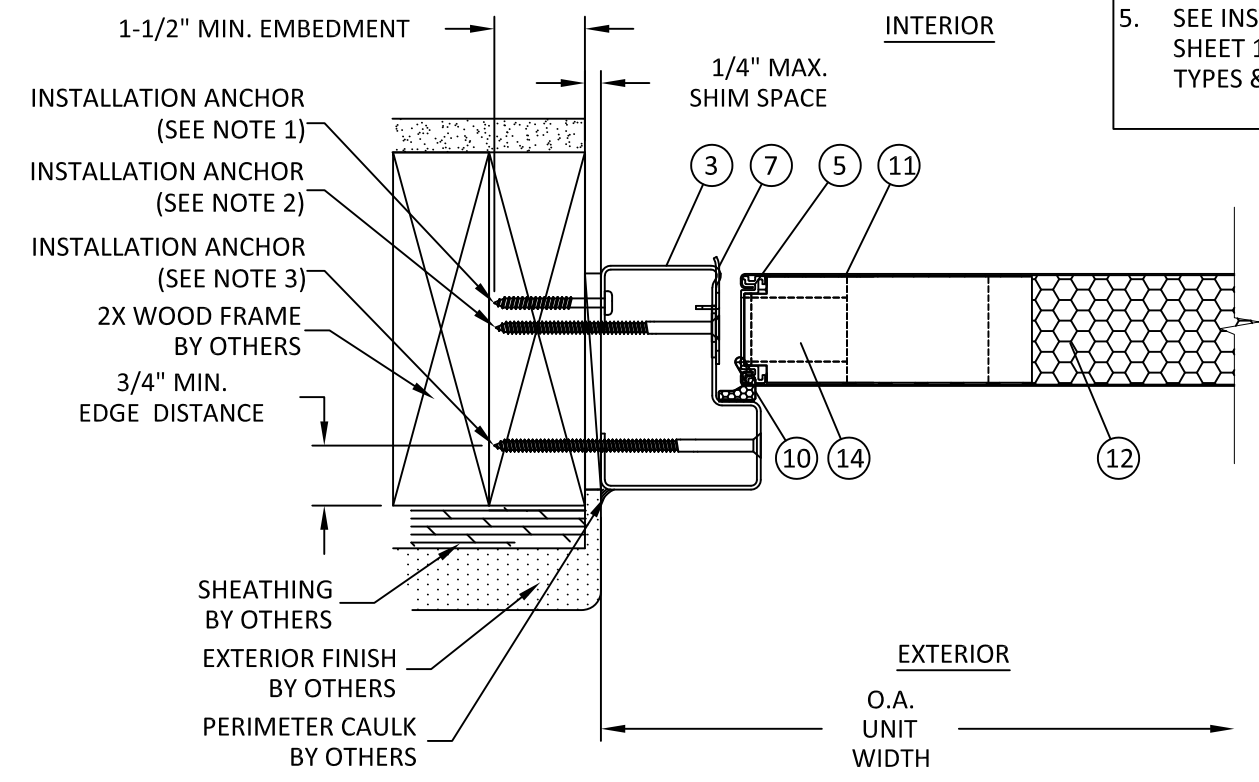

F
4 **HORIZONTAL SECTION**
JAMB - 2X WOOD FRAME, TYP.

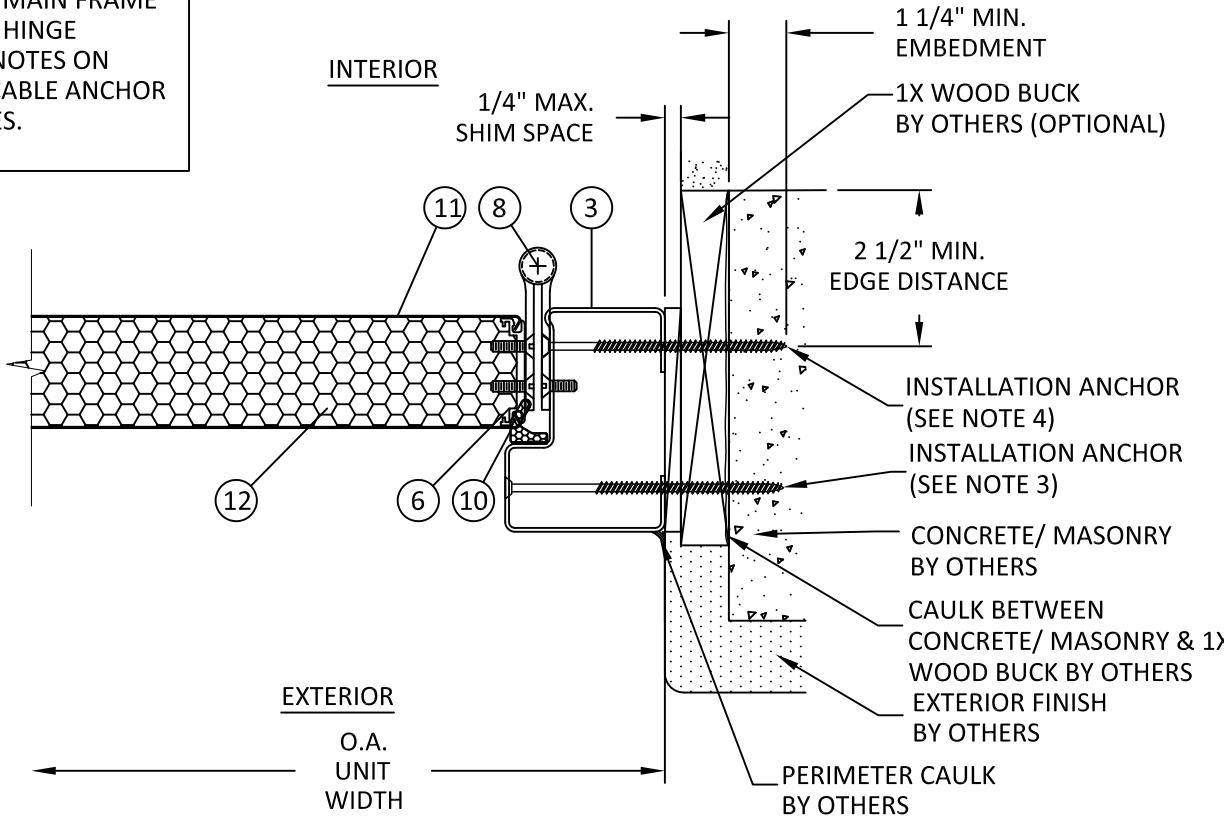

G
4 **HORIZONTAL SECTION**
JAMB - MASONRY/CONCRETE, TYP.

s:\projects\plyco corp\tdi-19-1128 -tdi submittal - series 20ev and 95ev gld and opa doors\dwg\pc0031.pco031.dwg 12/17/2020 6:42 PM

BILL OF MATERIALS

ITEM NO.	DESCRIPTION	PARTS NUMBERS	MATERIAL	MANUFACTURER
1	FRAME SILL	1647	6063-T5	MODERN DOOR
2	FRAME HEAD	1880	6063-T5	MODERN DOOR
3	FRAME JAMB	1539	STEEL	MODERN DOOR
4	HEAD & SILL RAIL	1838-1A	6063-T5	MODERN DOOR
5	STRIKE RAIL	1839	6063-T5	MODERN DOOR
6	HINGE RAIL	1840-B	6063-T5	MODERN DOOR
7	STRIKE PLATE	---	STEEL	MODERN DOOR
8	4" BUTT HINGE	---	STEEL	MODERN DOOR
9	DOOR SWEEP	---	PVC-ALCRYN	MODERN DOOR
10	FOAM FILLED WEATHER SEAL	WS-016	FOAM	MODERN DOOR
11	DOOR SKIN	---	0.021" STEEL	MODERN DOOR
12	PANEL CORE	---	POLYURETHANE	MODERN DOOR
13	---	---	---	---
14	LOCK BLOCK	---	WOOD	MODERN DOOR
15	LOCKSET	---	STEEL	SCHLAGE
16	DEADBOLT (OPTIONAL)	---	STEEL	SCHLAGE
17	DOOR CAP	---	PVC	MODERN DOOR
18	WEATHER SEAL	9650	PVC	MODERN DOOR
19	ADA SILL (OPTIONAL)	1572	6063-T5	MODERN DOOR
20	DOOR SWEEP	1852	PVC-ALCRYN	MODERN DOOR
21	PANEL SEAL	1929	6063-T5	MODERN DOOR

NOTE: ALL EXPOSED STEEL COMPONENTS ARE GALVANIZED AND SHOP PRIMED.

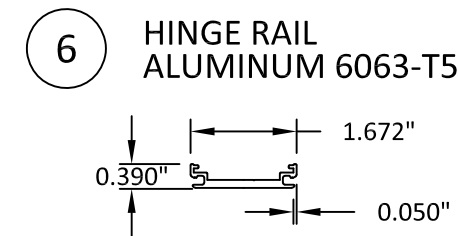
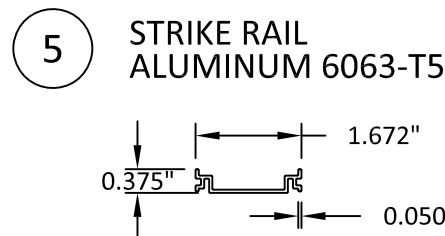
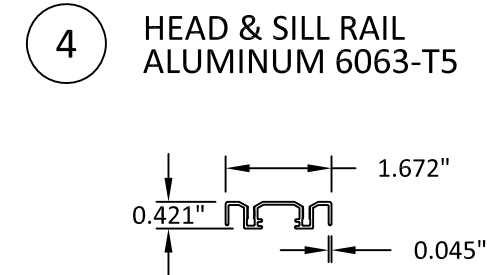
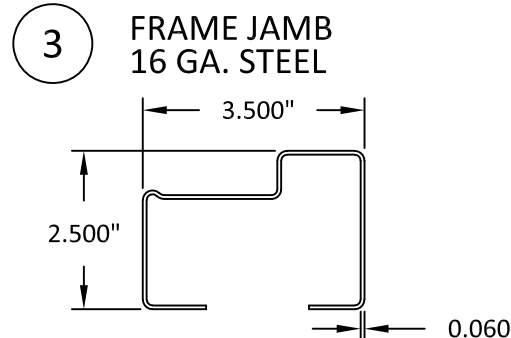
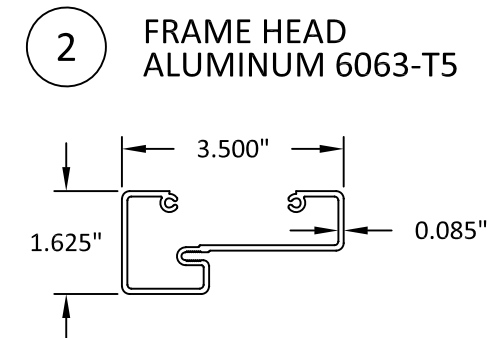
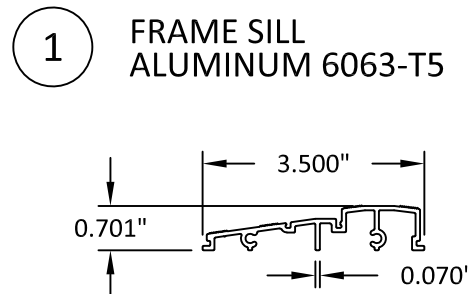
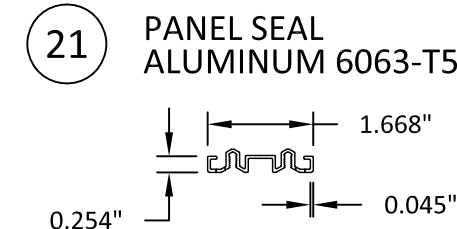
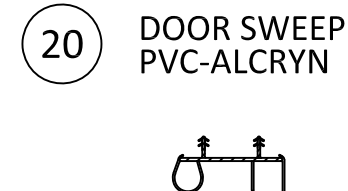
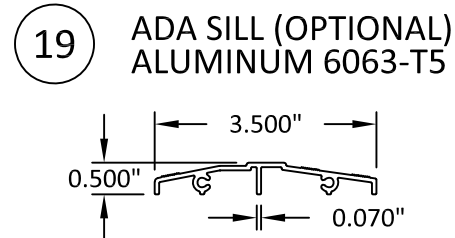
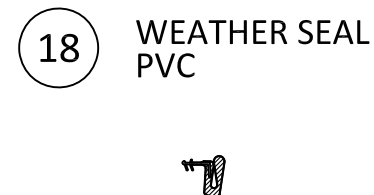
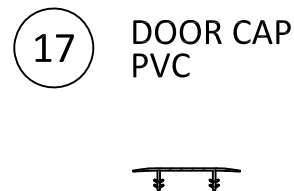
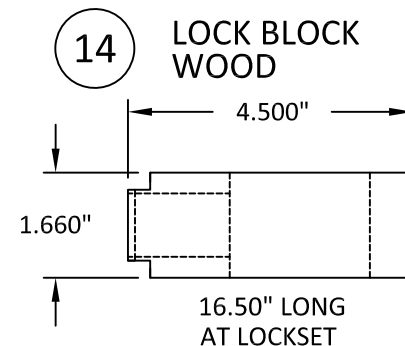
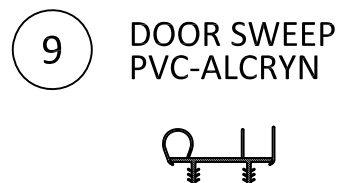
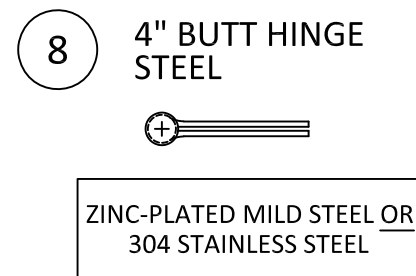
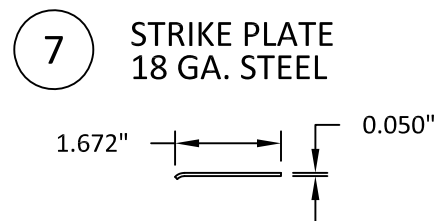

PLYCO

PLYCO CORPORATION
P.O. BOX 386
500 INDUSTRIAL RD.
ELKHART LAKE, WI 53020
PH: (920) 876-3611 FAX: (920) 876-3527

TITLE: SERIES 20EV FLUSH STEEL
INSWING DOOR (NON-IMPACT)

COMPONENTS &
BILL OF MATERIALS

PREPARED BY:
BUILDING DROPS, INC.
398 E. DANIA BEACH BLVD., STE. 338
DANIA BEACH, FL 33004
PH: (954) 399-8478
FAX: (954) 744-4738
WEB: www.buildingdrops.com



REMARKS	BY	DATE

THE INSTALLATION DETAILS DESCRIBED HEREIN ARE GENERIC AND MAY NOT REFLECT ACTUAL CONDITIONS FOR A SPECIFIC SITE. IF SITE CONDITIONS CAUSE INSTALLATION TO DEVIATE FROM THE REQUIREMENTS DETAILED HEREIN, A LICENSED ENGINEER OR ARCHITECT SHALL PREPARE SITE SPECIFIC DOCUMENTS FOR USE WITH THIS DOCUMENT.



HERMES F. NORERO, P.E.
TEXAS P.E. No. 118471
BUILDING DROPS, INC
398 E. DANIA BEACH BLVD. # 338
DANIA BEACH, FL 33004
TBPE FIRM No. 13734

DATE: **02.13.20**

DWG. BY: **MS**

CHK. BY: **HFN**

SCALE: **NTS**

DWG. #: **PCO031**

SHEET:

5

OF 5

s:\projects\plyco corp\tdi-19-1128 -tdi submittal - series 20ev and 95ev glkd and opa doors.dwg\pco031.pco031.dwg 12/17/2020 6:42 PM