

THERMA-TRU® DOORS

Fiber-Classic® & Smooth-Star®

GLAZED FIBERGLASS SINGLE DOOR in a COMPOSITE FRAME IN SWING/OUT SWING "IMPACT"

EVALUATED FOR USE IN THE STATE OF TEXAS

The Fiberglass Door system described herein complies with the 2018 International Residential Code (IRC), Sections R301 & R609 and the 2018 International Building Code (IBC), Sections 1404.13, 1609, 1709.5, 2403 and 2404 subject to the following conditions:

1. Anchors shall be as listed and spaced as shown in the details. Anchor embedment to base material shall be beyond wall dressing or stucco.
2. This system has been tested and evaluated as a large missile impact protective system for installation in areas that require wind borne debris protection. This product meets missile level "D" as defined in ASTM E 1996.
3. Allowable design pressure requirements must be equal to or less than the design pressure rating shown in the design pressure chart, sheet 1 of this drawing.
4. Conditions not covered by this drawing are subject to further engineering analysis.
5. Fiber-Classic and Smooth-Star Door & Sidelite panels require the use of "J" part numbers. These door panels must be stained or painted within six months of installation.

TABLE OF CONTENTS

SHEET #	DESCRIPTION
1	Typical Elevations, Design Pressures & General Notes
2	Door Panel Details
3	Elevations
4	Horizontal & Vertical Cross Sections (2X Buck)
5	Vertical Cross Sections (Thresholds)
6	Buck & Frame Anchoring
7	Hardware Details
8	Bill of Materials & Components

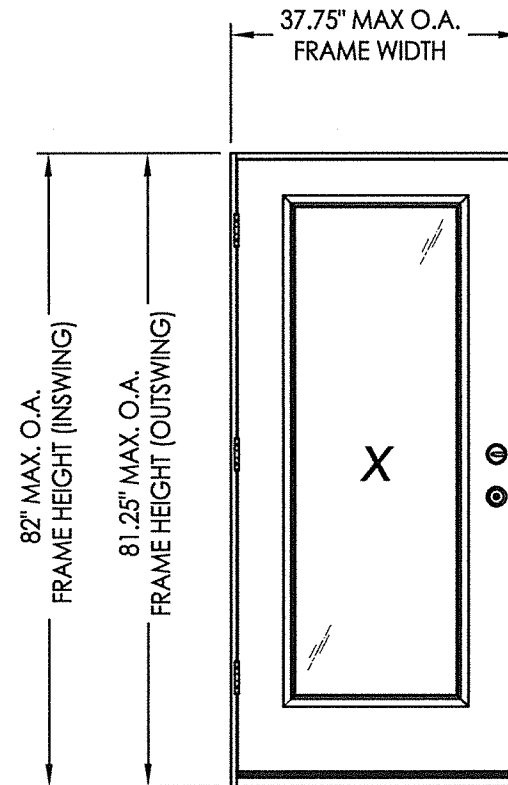

CONFIGURATION	DESIGN PRESSURE (PSF) IN SWING		DESIGN PRESSURE (PSF) OUT SWING	
	POSITIVE	NEGATIVE	POSITIVE	NEGATIVE
X	+50.0	-55.0	+50.0	-50.0

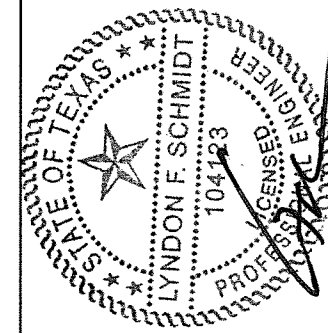

Documents Prepared By: Lyndon F. Schmidt, P.E.
TEXAS P.E. #104123

RW BUILDING CONSULTANTS, INC.
P.O. Box 230 Valrico FL 33595
Phone No.: 813.659.9197

TEXAS BOARD OF PROFESSIONAL ENGINEERS
CERTIFICATE OF REGISTRATION # F-11852

PRODUCT: THERMA-TRU
FIBERGLASS DOOR

PART OR ASSEMBLY:
TYPICAL ELEVATION, DESIGN
PRESSURES & GENERAL NOTES

NO.	DATE	BY	REVISIONS

DATE: 5/24/21

SCALE: N.T.S.

DWG. BY: RW

CHK. BY: LFS

DRAWING NO.:
TX-5206

SHEET 1 OF 8

Z:\Clients\Therma Tru PERMANENT\B - Texas Dept of Ins\TDI - ID XXXX - 6'8 GLZ FG Imp Comp Jamb (TX 5206-5208)\C - Drawings\TX-5206-5208.dwg

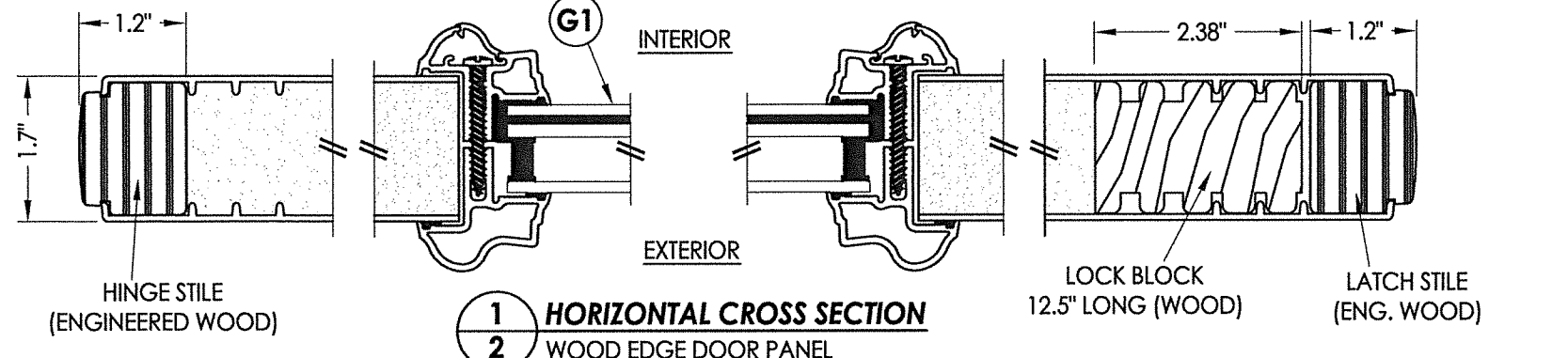

1 HORIZONTAL CROSS SECTION
2 WOOD EDGE DOOR PANEL

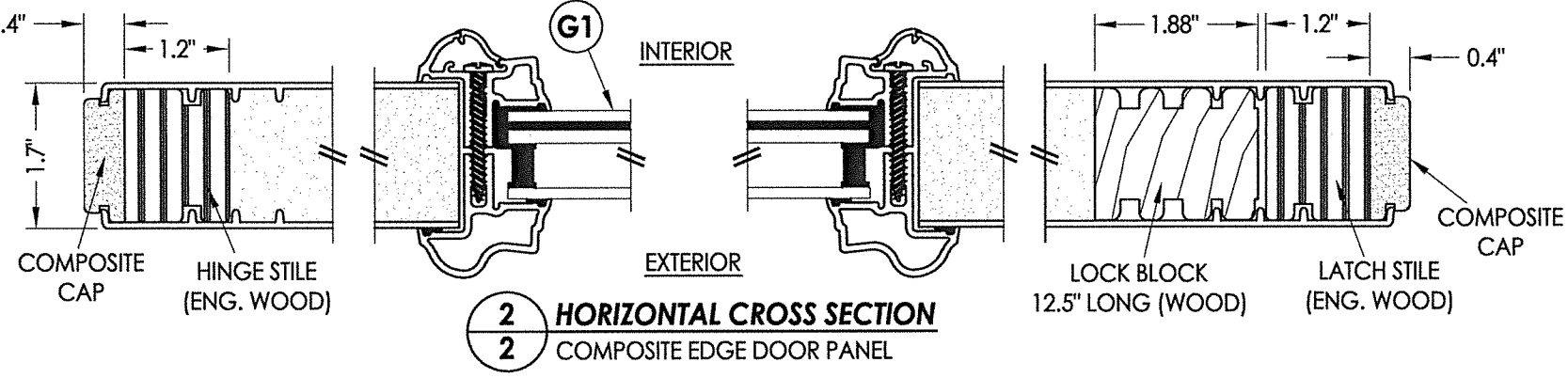

2 HORIZONTAL CROSS SECTION
2 COMPOSITE EDGE DOOR PANEL

NOTE: BOOK, HYBRID & U1 DOORS
MAY EACH BE FABRICATED AS WOOD
OR COMPOSITE EDGE DOORS.

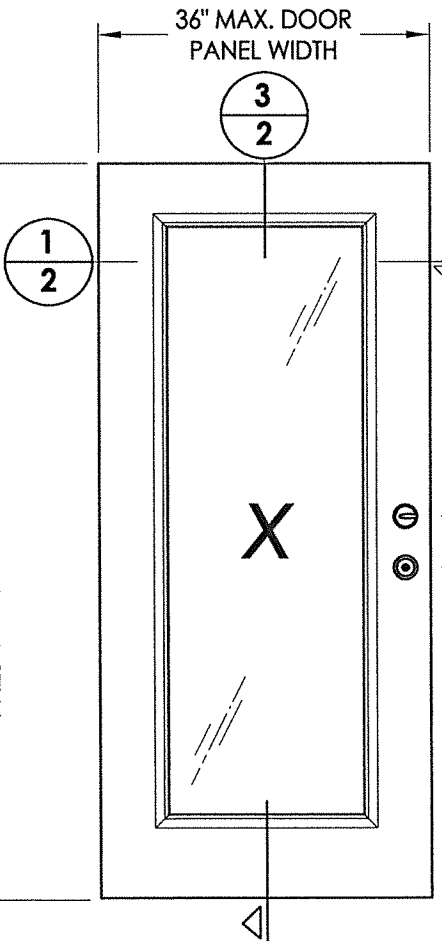
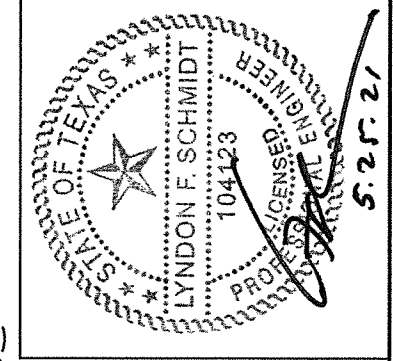

40 FIBERGLASS DOOR PANEL
BOOK DOOR

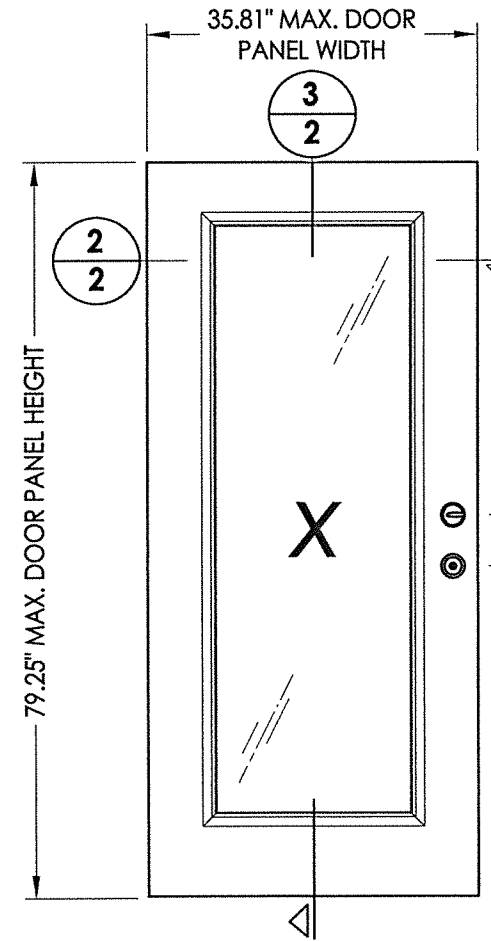

41 FIBERGLASS DOOR PANEL
HYBRID DOOR

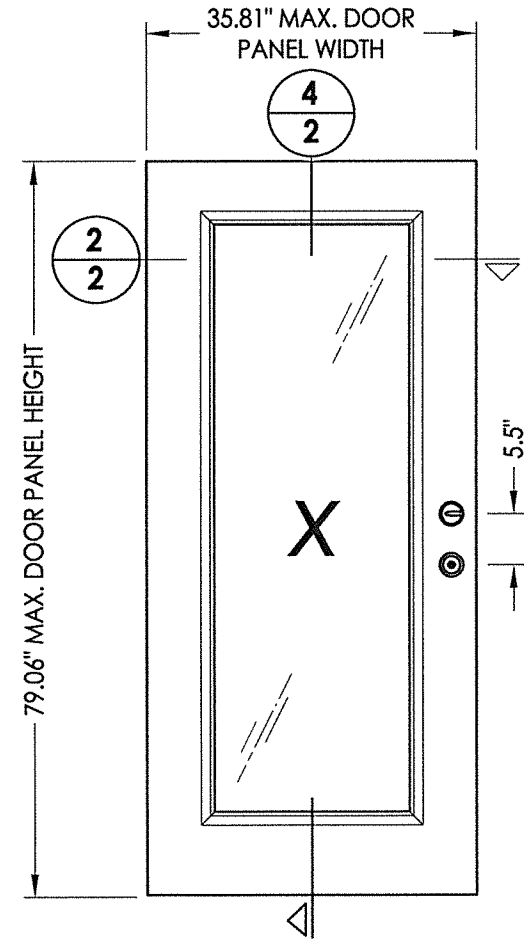

42 FIBERGLASS DOOR PANEL
U1 DOOR

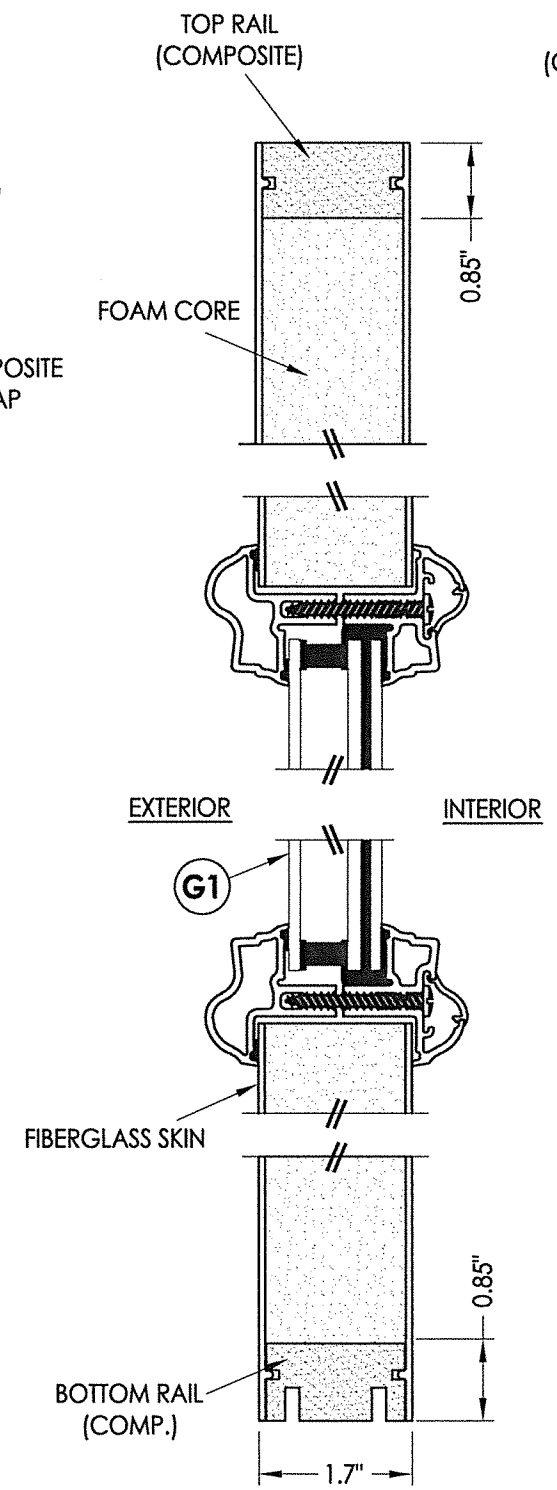

3 VERTICAL CROSS SECTION
2 WOOD EDGE DOOR PANEL

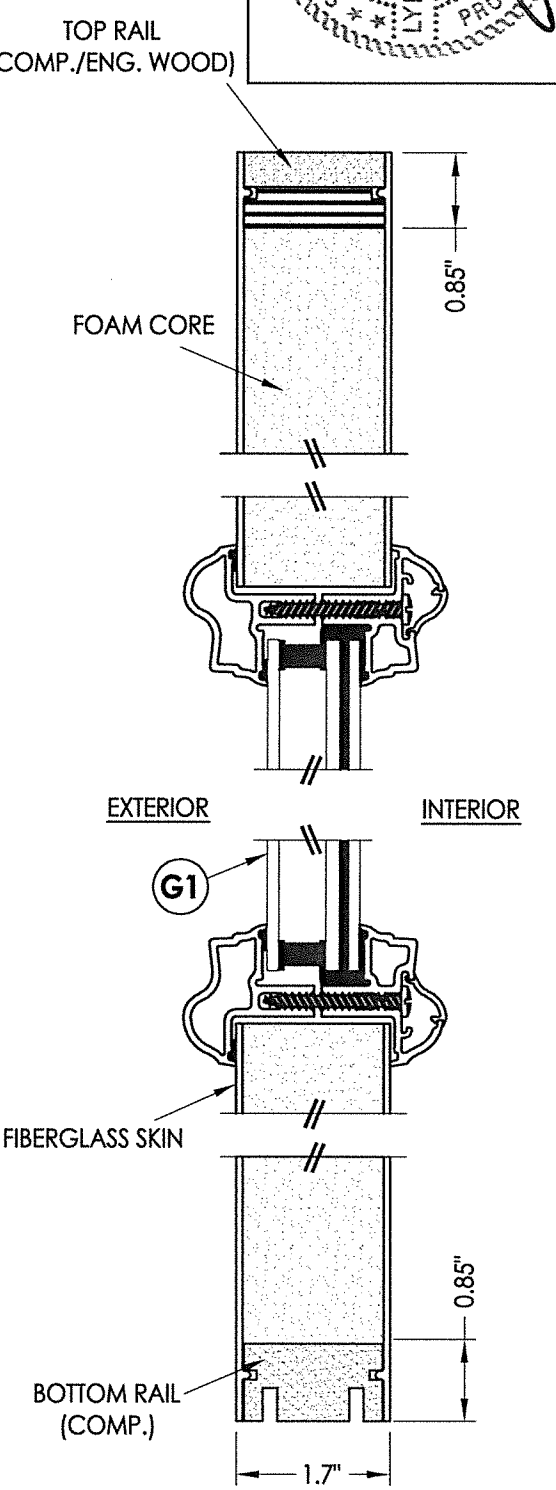

4 VERTICAL CROSS SECTION
2 COMPOSITE EDGE DOOR PANEL

FIBERGLASS SKIN: 0.073\"/>

Documents Prepared By: Lyndon F. Schmidt, P.E. TEXAS P.E. #104123		RW BUILDING CONSULTANTS, INC. P.O. Box 230 Valrico FL 33595 Phone No.: 813.659.9197 TEXAS BOARD OF PROFESSIONAL ENGINEERS CERTIFICATE OF REGISTRATION # F-11852
PRODUCT: THERMA-TRU FIBERGLASS DOOR	PART OR ASSEMBLY: DOOR PANEL DETAILS	
NO.	DATE	BY
		REVISIONS
DATE: 5/24/21		
SCALE: N.T.S.		
DWG. BY: RW		
CHK. BY: LFS		
DRAWING NO.: TX-5206		
SHEET 2 OF 8		

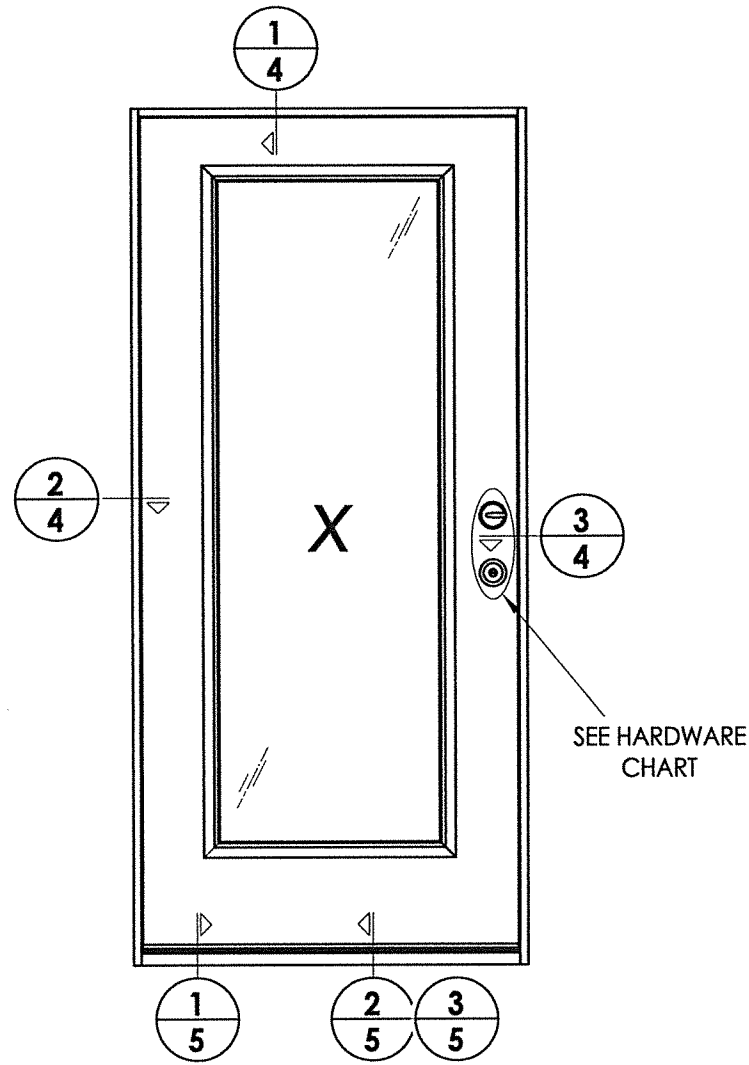

HARDWARE TABLE		
MANUFACTURER	MODEL	
SCHLAGE	KNOB:	F51
	DEADBOLT:	B60
KWIKSET	KNOB:	SIGNATURE SERIES
	DEADBOLT:	SIGNATURE SERIES (980)

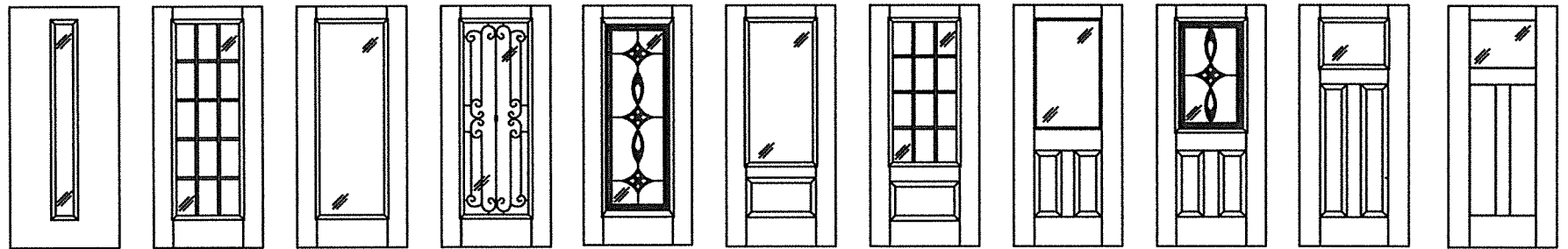

Fiber-Classic/Smooth-Star Door Panel Options
 Products approved include all embossed and recessed panel doors.
 Similar glazed panel configurations are allowed.
 Panels shown are for illustration and are representative only.

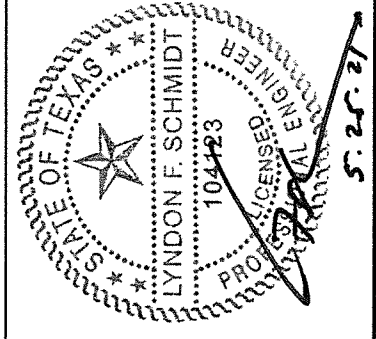

Documents Prepared By: Lyndon F. Schmidt, P.E.
 TEXAS P.E. #104123

R.W. BUILDING CONSULTANTS, INC.
 P.O. Box 230 Vairico FL 33595
 Phone No.: 813.659.9197

TEXAS BOARD OF PROFESSIONAL ENGINEERS
 CERTIFICATE OF REGISTRATION # F-11852

PRODUCT: THERMA-TRU FIBERGLASS DOOR

PART OR ASSEMBLY:

ELEVATIONS

NO.	DATE	BY

DATE: 5/24/21
 SCALE: N.T.S.
 DWG. BY: RW
 CHK. BY: LFS
 DRAWING NO.: TX-5206
 SHEET 3 OF 8

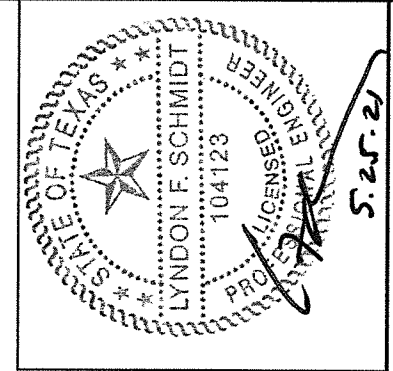

Documents Prepared By: Lyndon F. Schmidt, P.E.
TEXAS P.E. #104123

RW BUILDING CONSULTANTS, INC.
P.O. Box 230 Vairico FL 33595
Phone No.: 813.659.9197
TEXAS BOARD OF PROFESSIONAL ENGINEERS
CERTIFICATE OF REGISTRATION # F-11852

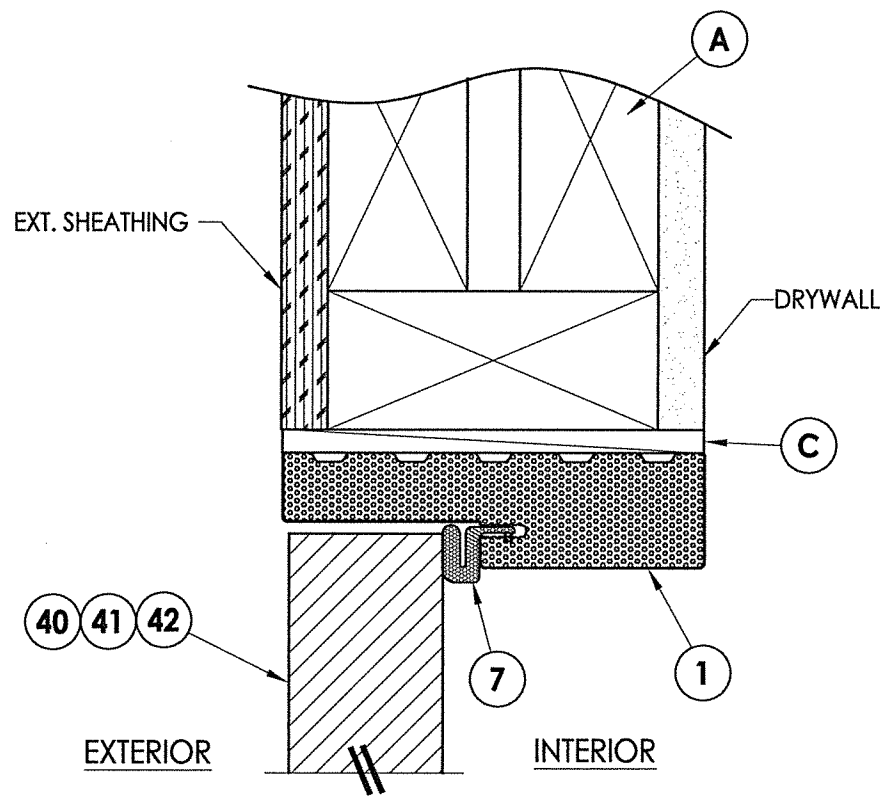

1 VERTICAL CROSS SECTION
4 Shown w/ 2X Buck
Outswing shown (Inswing similar)

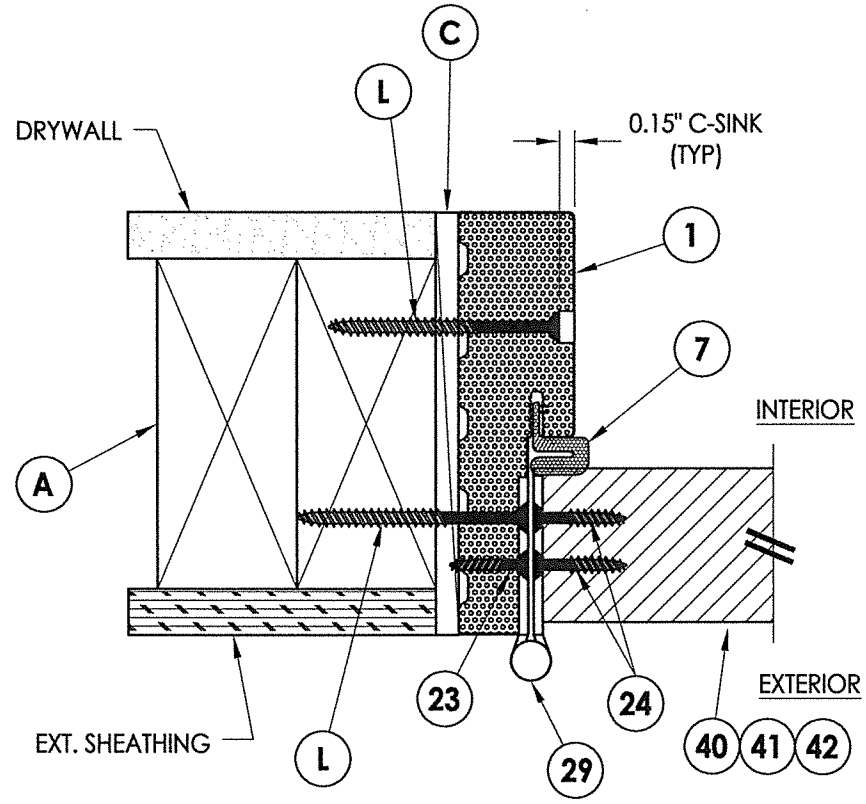

2 HORIZONTAL CROSS SECTION
4 Shown w/ 2X Buck
Outswing shown (Inswing similar)

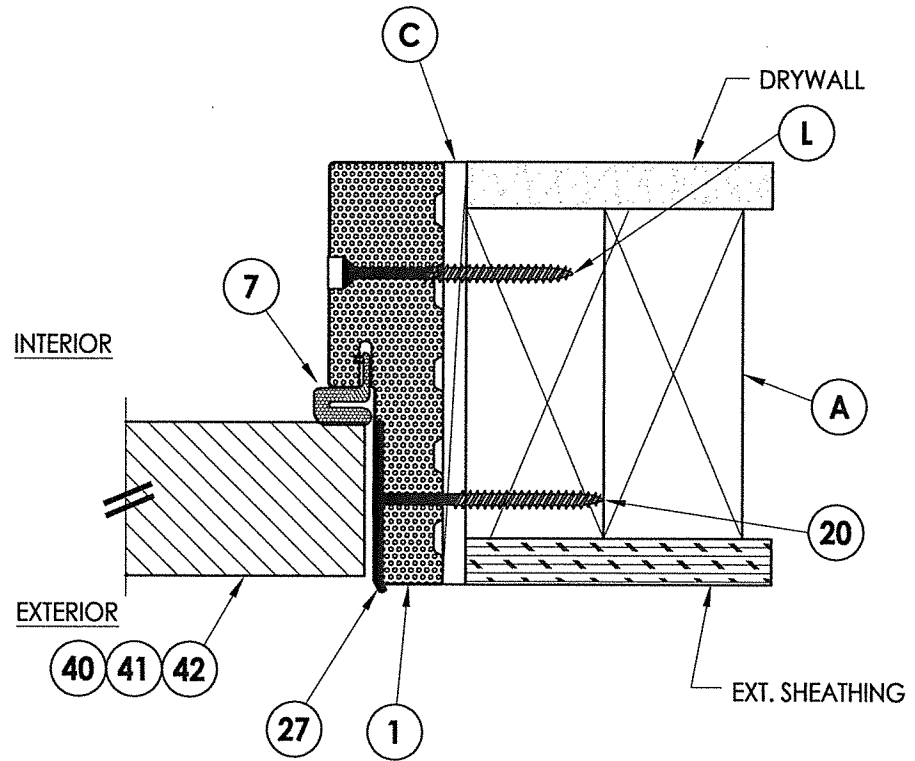

3 HORIZONTAL CROSS SECTION
4 Shown w/ 2X Buck
Outswing shown (Inswing similar)

PRODUCT: THERMA-TRU
FIBERGLASS DOOR
PART OR ASSEMBLY:
HORIZONTAL & VERTICAL
CROSS SECTIONS (2X BUCK)

NO.	DATE	BY	REVISIONS

DATE: 5/24/21
SCALE: N.T.S.
DWG. BY: RW
CHK. BY: LFS
DRAWING NO.: TX-5206
SHEET 4 OF 8

Z:\Clients\Therma Tru PERMANENT\B - Texas Dept of Ins\TDI - ID XXXX - 6'8 GLZ FG Imp Comp Jambs (TX 5206-5208)\C - Drawings\TX-5206-5208.dwg

Notes:

- 1. Sill Item #32 is attached to jambs w/ (3) #8 X 2-1/2" pfh screws at each end.
- Sill Item #33 is attached to jambs w/ (2) #8 X 2-1/2" pfh screws at each end.
- Sill Item #34 is attached to jambs utilizing (2) #10 X 2" pph SMS at each end.

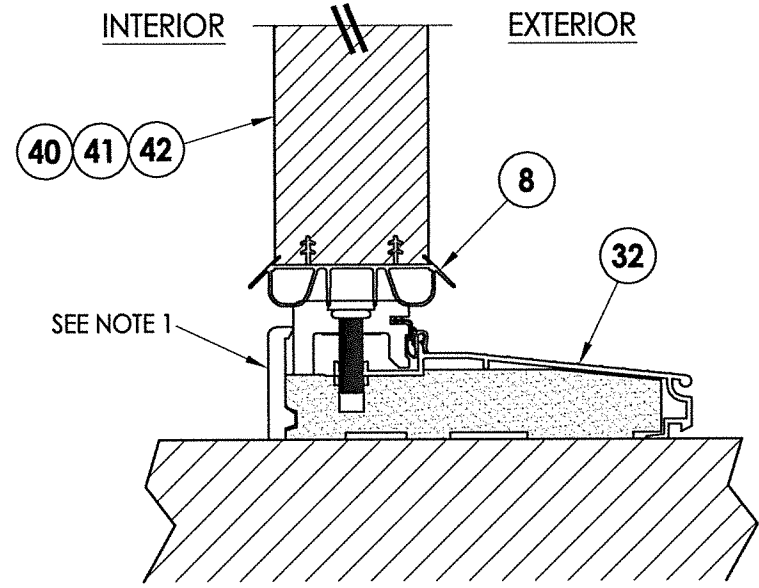

1 VERTICAL CROSS SECTION
5 Inswing Sill

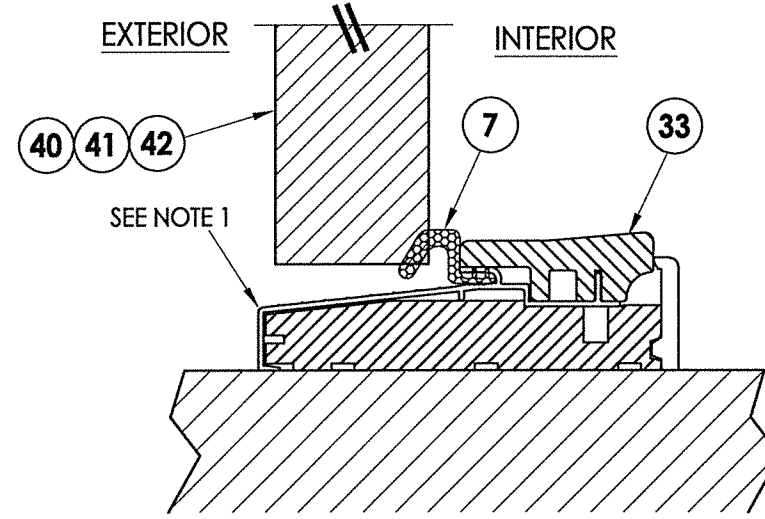

2 VERTICAL CROSS SECTION
5 Outswing Sill

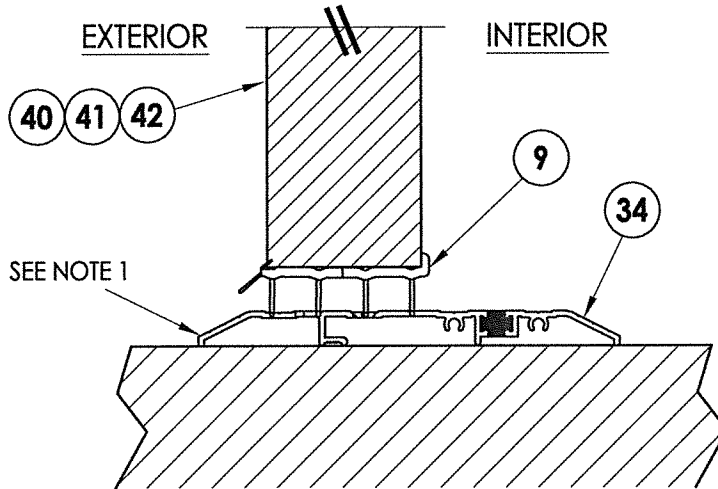

3 VERTICAL CROSS SECTION
5 Public Access Sill

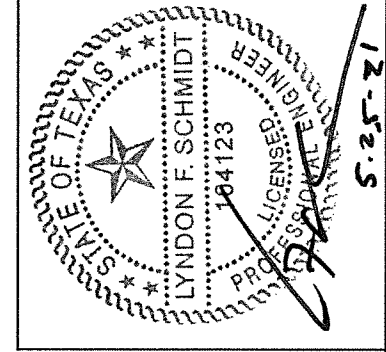

Documents Prepared By: Lyndon F. Schmidt, P.E.
TEXAS P.E. #104123

RW BUILDING CONSULTANTS, INC.
P.O. Box 230 Valrico FL 33595
Phone No.: 813.659.9197

TEXAS BOARD OF PROFESSIONAL ENGINEERS
CERTIFICATE OF REGISTRATION # F-11852

PRODUCT: THERMA-TRU FIBERGLASS DOOR
PART OR ASSEMBLY: VERTICAL CROSS SECTIONS (THRESHOLDS)

NO.	DATE	BY	REVISIONS

DATE: 5/24/21
SCALE: N.T.S.
DWG. BY: RW
CHK. BY: LFS
DRAWING NO.: TX-5206
SHEET 5 OF 8

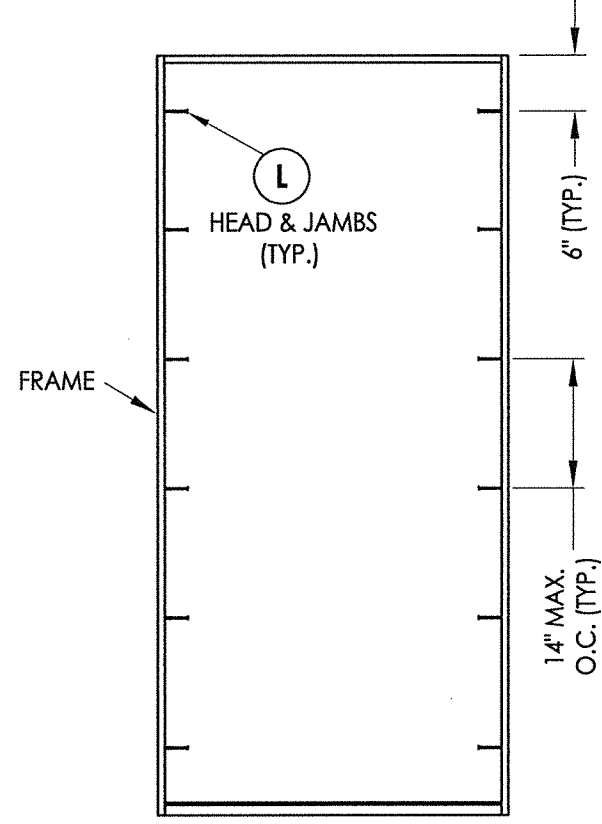

FRAME ANCHORING

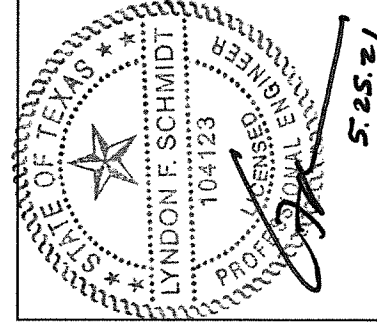
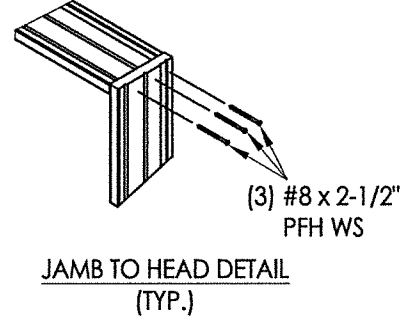

Documents Prepared By: Lyndon F. Schmidt, P.E.
TEXAS P.E. #104123

RW BUILDING CONSULTANTS, INC.
P.O. Box 230 Valrico FL, 33595
Phone No.: 813.659.9197
TEXAS BOARD OF PROFESSIONAL ENGINEERS
CERTIFICATE OF REGISTRATION # F-11852

PRODUCT: THERMA-TRU
FIBERGLASS DOOR
PART OR ASSEMBLY:
BUCK & FRAME ANCHORING

NO.	DATE	BY	REVISIONS

DATE: 5/24/21
SCALE: N.T.S.
DWG. BY: RW
CHK. BY: LFS
DRAWING NO.: TX-5206
SHEET 6 of 8

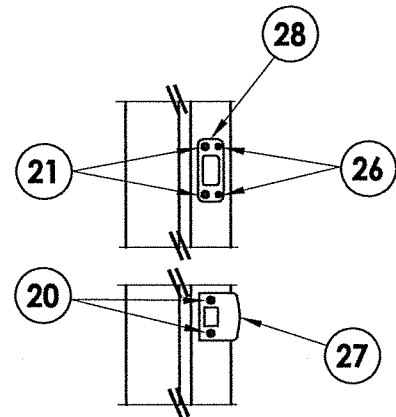

LATCH & DEADBOLT DETAIL
Kwikset

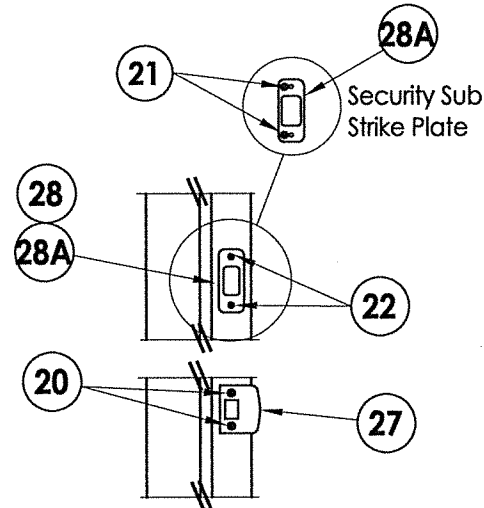

LATCH & DEADBOLT DETAIL
Schlage

LATCH & DEADBOLT STRIKE DETAILS

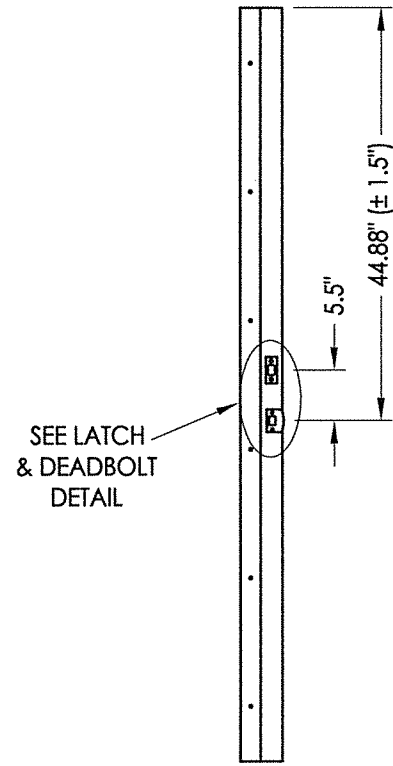

STRIKE JAMB
Latch and Deadbolt

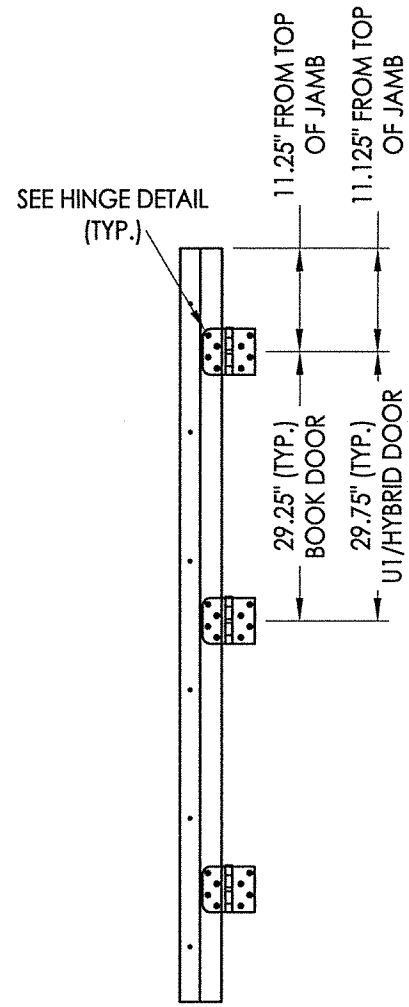

HINGE JAMB

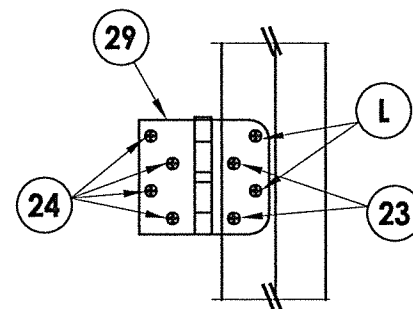

HINGE DETAIL
Inswing

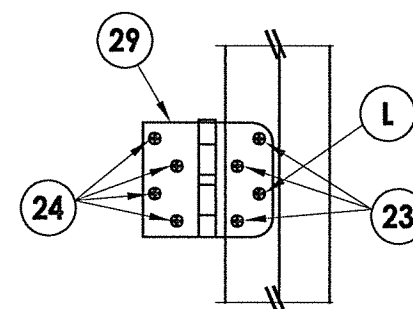

HINGE DETAIL
Outswing

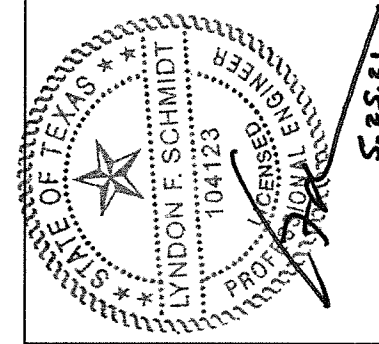

Documents Prepared By: Lyndon F. Schmidt, P.E.
TEXAS P.E. #104123

RW BUILDING CONSULTANTS, INC.
P.O. Box 230 Valrico FL 33595
Phone No.: 813.659.9197

TEXAS BOARD OF PROFESSIONAL ENGINEERS
CERTIFICATE OF REGISTRATION # F-11852

PRODUCT:	THERMA-TRU FIBERGLASS DOOR
PART OR ASSEMBLY:	HARDWARE DETAILS

NO.	DATE	BY	REVISIONS

DATE: 5/24/21
SCALE: N.T.S.
DWG. BY: RW
CHK. BY: LFS
DRAWING NO.: TX-5206
SHEET 7 OF 8

Z:\Clients\Therma Tru PERMANENT\B - Texas Dept of Ins\TDI - ID XXXX - 6'8 GLZ FG Imp Comp Jamb (TX 5206-5208)\C - Drawings\TX-5206-5208.dwg

BILL OF MATERIALS		
ITEM #	DESCRIPTION	MATERIAL
A	2X FRAMING (SG >= 0.42)	WOOD
C	1/4" MAX. SHIM SPACE	-
F	#10 X 2" PFH WOOD SCREW	STEEL
L	#10 X 2-1/2" PFH WOOD SCREW (1.15" MIN. EMBEDMENT)	STEEL
1	COMPOSITE JAMB	COMP
7	WEATHERSTRIP	FOAM
8	DOOR SWEEP	VINYL
9	SWEEP (USE w/ PUBLIC ACCESS THRESHOLD)	VINYL
20	#8 X 2-1/2" PFH WOOD SCREW	STEEL
21	#12 X 2-1/2" PFH WOOD SCREW	STEEL
22	#8 X 3/4" PFH WOOD SCREW	STEEL
23	#9 X 3/4" PFH WOOD SCREW	STEEL
24	#9 X 1" PFH WOOD SCREW	STEEL
26	#8 X 5/8" PFH WOOD SCREW	STEEL
27	LATCH STRIKE PLATE	STEEL
28	DEADBOLT STRIKE PLATE	STEEL
28A	DEADBOLT SUB-STRIKE PLATE	STEEL
29	4" X 4" HINGE	STEEL
32	INSWING THRESHOLD	ALUM/COMP
33	OUTSWING THRESHOLD	ALUM/COMP
34	PUBLIC ACCESS THRESHOLD	ALUM
40	DOOR PANEL (BOOK)	-
41	DOOR PANEL (HYBRID)	-
42	DOOR PANEL (U1)	-

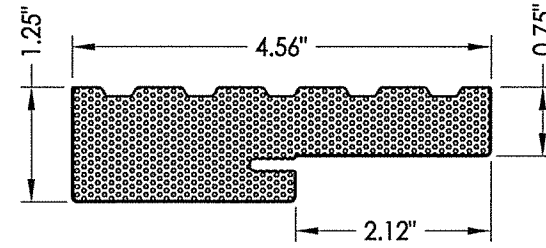

1 COMPOSITE JAMB

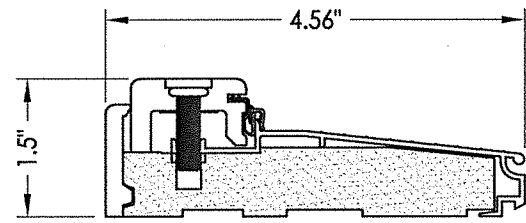

32 INSWING THRESHOLD
Adjustable Composite Sill

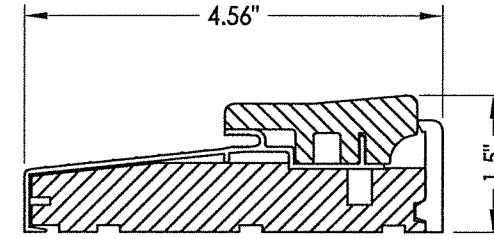

33 OUTSWING THRESHOLD
Composite Sill

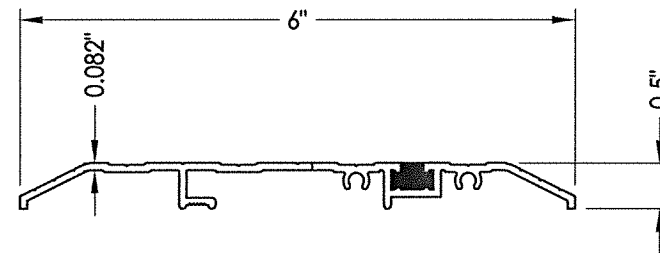

34 PUBLIC ACCESS THRESHOLD

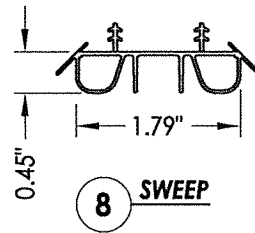

8 SWEEP

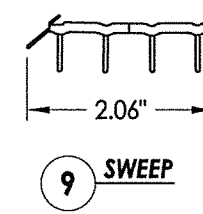

9 SWEEP

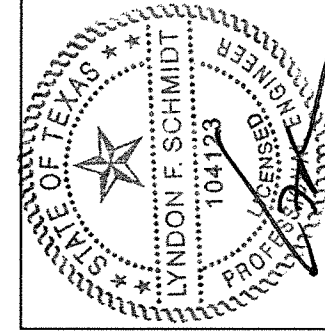

5.25.21

Documents Prepared By: Lyndon F. Schmidt, P.E.
TEXAS P.E. #104123

RW BUILDING CONSULTANTS, INC.
P.O. Box 230 Valrico FL 33595
Phone No.: 813.659.9197

TEXAS BOARD OF PROFESSIONAL ENGINEERS
CERTIFICATE OF REGISTRATION # F-11852

PRODUCT: THERMA-TRU
FIBERGLASS DOOR

PART OR ASSEMBLY:
BILL OF MATERIALS
& COMPONENTS

NO.	DATE	BY	REVISIONS

DATE: 5/24/21

SCALE: N.T.S.

DWG. BY: RW

CHK. BY: LFS

DRAWING NO.:

TX-5206

SHEET 8 OF 8