

EYEWALL ARMOR 44mm ALUMINUM ROLL-UP SHUTTER

WITH END RETENTION SLATS AND RAILS

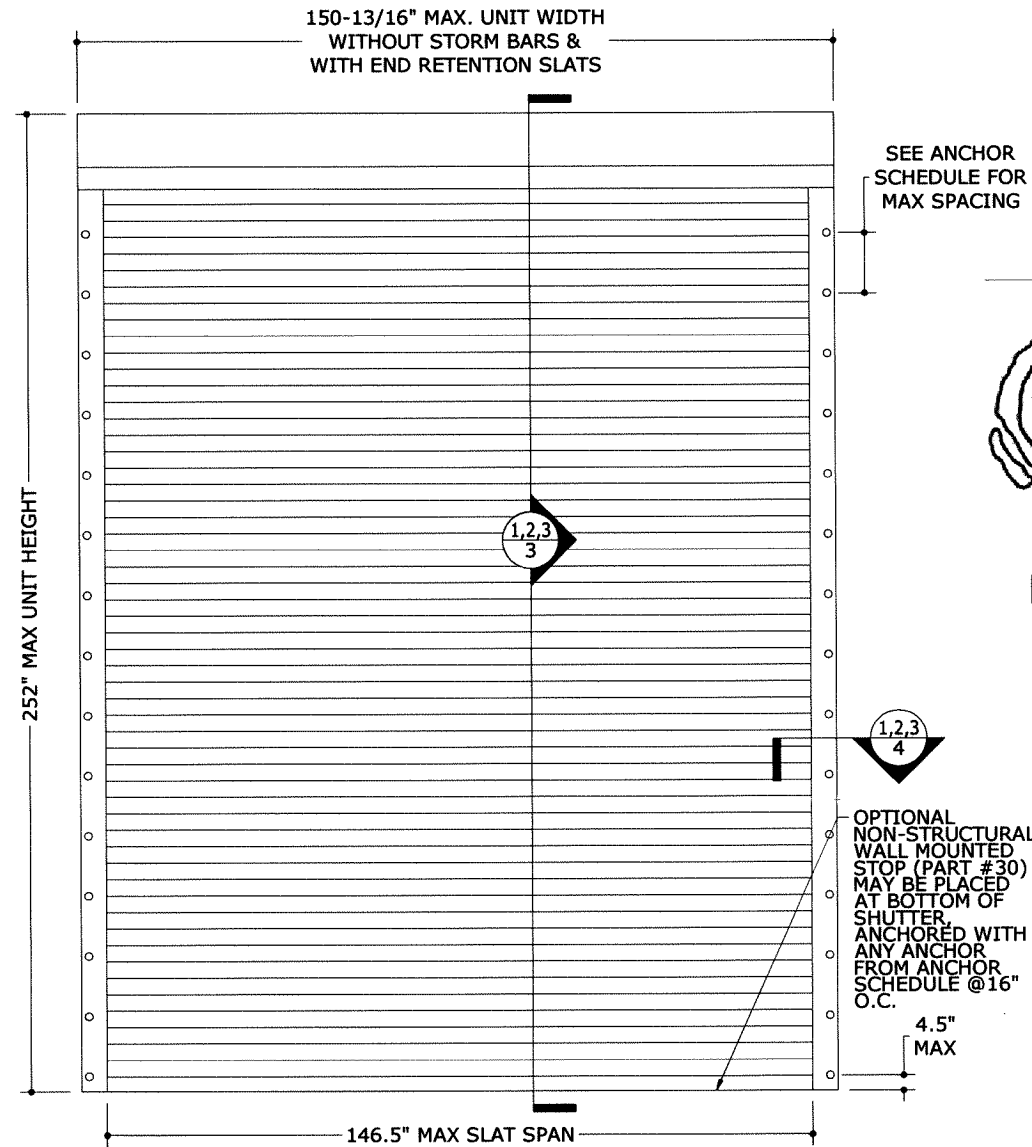

TABLE 1
SPAN SCHEDULE
NO STORM BARS

SLAT SPAN	ALLOWABLE DESIGN PRESSURE
61.2"	+ 93.0 PSF - 93.0 PSF
70.0"	+ 78.6 PSF - 81.3 PSF
80.0"	+ 69.2 PSF - 73.8 PSF
90.0"	+ 63.4 PSF - 69.3 PSF
98.3"	+ 60.0 PSF - 66.7 PSF
100.0"	+ 58.8 PSF - 65.0 PSF
110.0"	+ 52.8 PSF - 57.1 PSF
120.0"	+ 48.3 PSF - 51.0 PSF
130.0"	+ 44.6 PSF - 46.1 PSF
140.0"	+ 41.7 PSF - 42.2 PSF
146.5"	+ 40.0 PSF - 40.0 PSF

- TABLE 1 NOTES:**
- SLAT SPAN IS DEFINED AS THE DISTANCE BETWEEN RAILS FOR SINGLE SPAN ASSEMBLIES.
 - LINEAR INTERPOLATION BETWEEN SHUTTER SPANS IS NOT PERMITTED. FOR SPANS BETWEEN THOSE INDICATED ABOVE, THE DESIGN PRESSURES FOR THE NEXT HIGHER SPAN SHALL BE USED.

TABLE 2
MINIMUM GLAZING SEPARATION
NO STORM BARS

SLAT SPAN	INSTALLATIONS ≤ 30' ABOVE GRADE	INSTALLATIONS > 30' ABOVE GRADE
61.2"	4.5"	4.5"
70.0"	4.8"	4.4"
80.0"	9.1"	9.1"
90.0"	6.3"	6.3"
98.3"	6.3"	6.3"
100.0"	9.4"	6.4"
110.0"	9.4"	6.8"
120.0"	9.4"	7.3"
130.0"	9.4"	7.8"
140.0"	9.4"	8.4"
146.5"	9.4"	8.8"

- TABLE 2 NOTES:**
- SLAT SPAN IS DEFINED AS THE DISTANCE BETWEEN RAILS FOR SINGLE SPAN ASSEMBLIES
 - SEPARATION FROM GLAZING IS NOT REQUIRED UNLESS LOCAL MUNICIPALITY ADOPTS ADDITIONAL CRITERIA.
 - LINEAR INTERPOLATION BETWEEN SHUTTER SPANS IS NOT PERMITTED. FOR SPANS BETWEEN THOSE INDICATED ABOVE, THE SEPARATION FROM GLASS FOR THE NEXT HIGHER SPAN SHALL BE USED.

1 END RETENTION SHUTTER W/O STORM BARS
1 N.T.S. EXTERIOR ELEV

GENERAL NOTES

1. THE SYSTEM DESCRIBED HEREIN HAS BEEN DESIGNED AND TESTED IN ACCORDANCE WITH THE INTERNATIONAL BUILDING CODE (2018) AND THE INTERNATIONAL RESIDENTIAL CODE (IRC), FOR USE IN ACCORDANCE WITH THE TEXAS DEPARTMENT OF INSURANCE, PER ASTM E330, E1886, AND E1996 STANDARDS.
2. NO 33-1/3% INCREASE IN ALLOWABLE STRESS HAS BEEN USED IN THE DESIGN OF THIS SYSTEM. WIND LOAD DURATION FACTOR Cd=1.6 HAS BEEN USED FOR WOOD ANCHOR DESIGN.
3. POSITIVE AND NEGATIVE DESIGN PRESSURES CALCULATED FOR USE WITH THIS SYSTEM SHALL BE DETERMINED PER SEPARATE ENGINEERING IN ACCORDANCE WITH THE GOVERNING CODE. PRESSURE REQUIREMENTS AS DETERMINED IN ACCORDANCE WITH ASCE 7 AND CHAPTER 1609 OF THE INTERNATIONAL BUILDING CODE SHALL BE LESS THAN OR EQUAL TO THE POSITIVE OR NEGATIVE DESIGN PRESSURE CAPACITY VALUES LISTED HEREIN FOR ANY ASSEMBLY AS SHOWN.
4. DESIGN PRESSURES NOTED HEREIN ARE BASED ON MAXIMUM TESTED PRESSURES DIVIDED BY A 1.5 SAFETY FACTOR.
5. THIS SYSTEM HAS BEEN DESIGNED WITH NO SEPARATION FROM GLAZING REQUIRED FOR ALL WIND ZONES, IN ACCORDANCE WITH ASTM E1996. IT IS ACCEPTABLE BY CODE UNLESS OPTIONAL CRITERIA IS INDEPENDENTLY ADOPTED BY THE AUTHORITY HAVING JURISDICTION

6. THE SYSTEM DETAILED HEREIN IS GENERIC AND DOES NOT PROVIDE INFORMATION FOR A SPECIFIC SITE. FOR SITE CONDITIONS DIFFERENT FROM THE CONDITIONS DETAILED HEREIN, A LICENSED ENGINEER OR REGISTERED ARCHITECT SHALL PREPARE SITE SPECIFIC DOCUMENTS FOR USE IN CONJUNCTION WITH THIS DOCUMENT. THESE INSTALLATION INSTRUCTIONS ARE PART OF A PRODUCT APPROVAL EVALUATION AND SHALL ONLY BE USED IN CONJUNCTION WITH THE EVALUATION REPORT SUBMITTED FOR THE SAME PRODUCT APPROVAL. THIS CERTIFICATION IS VALID FOR USE IN CONJUNCTION WITH THE MOST CURRENT REVISION OF FLORIDA PRODUCT APPROVAL #FL14235.2, ALUMINUM STORM BARS, HEADERS AND MULLIONS.
7. ROLL-UP MECHANISM AND HOOD ASSEMBLY ARE NOT PART OF THIS APPROVAL.
8. THIS DOCUMENT CONTAINS INFORMATION RELEVANT TO THE NECESSARY STRUCTURAL REQUIREMENTS OF THE SYSTEM INSTALLATION. COMPONENTS AND FASTENERS NOT REFERENCED WHICH ARE PART OF THE INTERNAL FABRICATION OF THE SPECIFIED SYSTEMS OR ASSEMBLIES SHALL BE PER MANUFACTURER PUBLISHED SPECIFICATIONS.
9. PERMIT HOLDER SHALL VERIFY THE ADEQUACY OF THE EXISTING STRUCTURE TO WITHSTAND SUPERIMPOSED LOADS. WOOD BUCKS (BY OTHERS) SHALL BE ANCHORED PROPERLY TO TRANSFER LOADS TO THE EXISTING STRUCTURE.

10. ALL EXTRUSIONS SHALL BE MINIMUM 6063-T5 ALUMINUM ALLOY, UNLESS NOTED OTHERWISE.
11. EACH SHUTTER ASSEMBLY SHALL BEAR A PERMANENT LABEL ON THE BOTTOM OF THE HOOD FACING THE EXTERIOR WITH THE FOLLOWING MINIMUM INFORMATION:
TOWN & COUNTRY INDUSTRIES
FORT LAUDERDALE, FL
9LB MISSILE LEVEL D - ASTM E1886, E1996 & E330
PRODUCT APPROVAL NUMBER
12. ALL BOLTS & WASHERS SHALL BE ZINC COATED STEEL, GALVANIZED STEEL, OR STAINLESS STEEL WITH A MINIMUM TENSILE YIELD STRENGTH OF 60 KSI. ALL ALUMINUM 3/16"Ø OR 1/4"Ø POP RIVETS SHALL HAVE A MINIMUM SHEAR ULTIMATE STRENGTH OF 42ksi.
13. ALL STEEL IN CONTACT WITH ALUMINUM SHALL BE PAINTED OR PLATED AS PRESCRIBED IN THE FLORIDA BUILDING CODE.

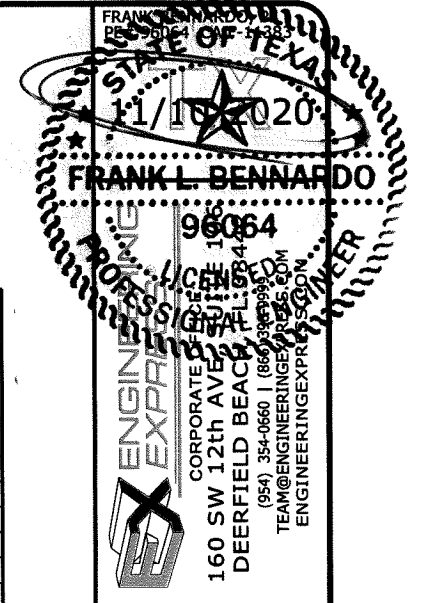

Town & Country
INDUSTRIES
Wholesale Aluminum and Building Products
A Division of Fabric Supply Co., Inc.
400 WEST MCNAB ROAD
FT. LAUDERDALE, FL 33309

DRWN	CHKD	DATE
KL	FLB	4/25/14
RWN	TSS	6/04/14
RWN	CSL	4/08/15
RWN	FLB	8/07/17
CCB	RWN	6/30/20

REMARKS:
INIT ISSUE
REV FOR TDI
2014 FBC
2017 FBC
2018 IBC

THIS DOCUMENT IS THE PROPERTY OF FRANK L. BENNARDO, P.E. AND SHALL NOT BE REPRODUCED IN WHOLE OR PART WITHOUT WRITTEN CONSENT OF FRANK L. BENNARDO, P.E. - ALTERNATIONS, ADDITIONS, IMPROVING OR OTHER MARKINGS TO THIS DOCUMENT ARE NOT PERMITTED AND INVALIDATE OUR CERTIFICATION.

COPYRIGHT FRANK L. BENNARDO P.E.

20-24244.3a

SCALE: -

PAGE DESCRIPTION:

1 of 15

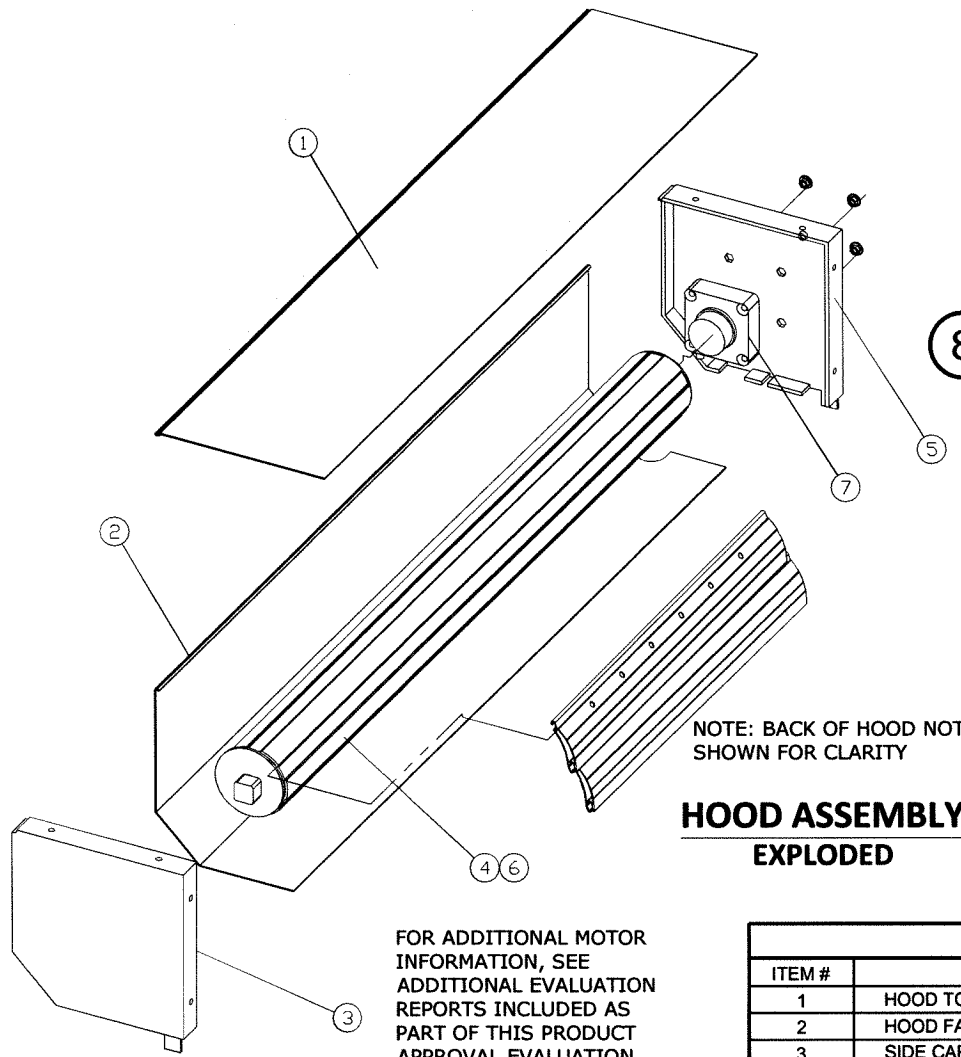

FOR ADDITIONAL MOTOR INFORMATION, SEE ADDITIONAL EVALUATION REPORTS INCLUDED AS PART OF THIS PRODUCT APPROVAL EVALUATION.

HOOD ASSEMBLY EXPLODED

8 SIDE RAIL COVER
6" = 1'-0" 6063-T6 ALUM

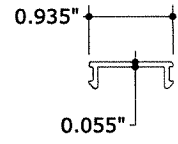

10a SIDE RAIL
6" = 1'-0" 6005-T5 ALUM

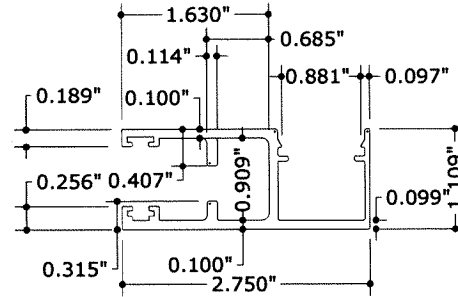

10b SIDE RAIL END RETENTION
6" = 1'-0" 6063-T6 ALUM

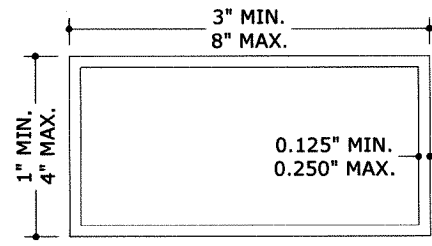
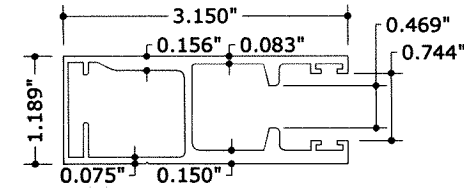

NOTE: SEE BILL OF MATERIALS (BOM) FOR TUBE SIZES AND MATERIALS

12-26 ALUMINUM TUBE
6" = 1'-0" MAT'L PER BOM

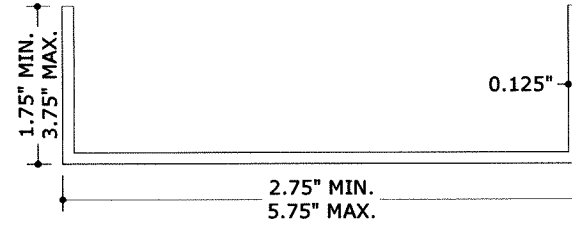

F_y = 30 ksi MINIMUM

27 STEEL REINFORCEMENT
6" = 1'-0" A36 GALV. STEEL OR STAINLESS STEEL

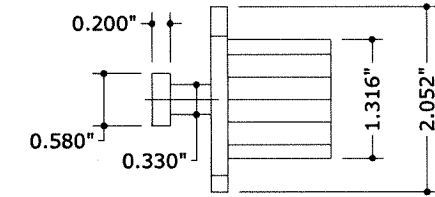
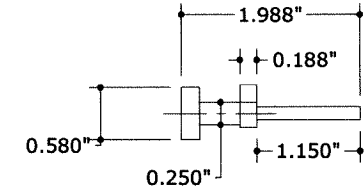

9 END RETENTION
6" = 1'-0" NYLON

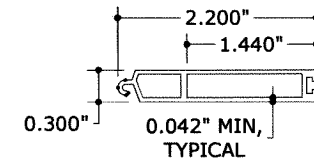

29 OPTIONAL BOTTOM SLAT
6" = 1'-0" 6063-T6 ALUM

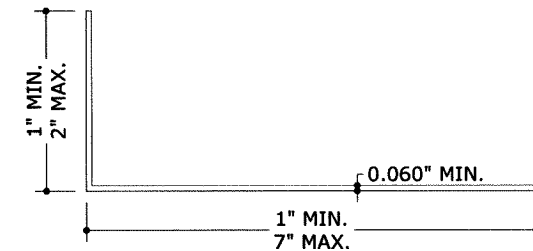

28 ALUMINUM ANGLE
6" = 1'-0" 6061-T6 OR 6005-T5 ALUM

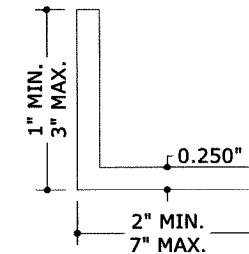

30 WALL MOUNTED STOP
6" = 1'-0" 6063-T6 ALUM

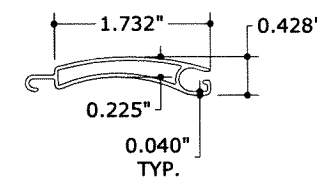

11 TYPICAL SLAT
6" = 1'-0" 6063-T6 ALUM

BILL OF MATERIALS		
ITEM #	DESCRIPTION	MATERIAL
1	HOOD TOP	3105-H14 ALUM
2	HOOD FACE	3105-H14 ALUM
3	SIDE CAP, RIGHT	CAST ALUM
4	MOTOR TUBE, 60-88mm DIAMETER, 3mm THICK	6063-T6 ALUM
4	MOTOR TUBE, 60-100mm DIAMETER, 3mm THICK	6063-T6 ALUM
5	SIDE CAP, LEFT	CAST ALUM
6	IDLE BEARING	NYLON/STEEL
7	MANUAL GEAR OR ELECTRONIC MOTOR	
8	SIDE RAIL COVER	6063-T6 MIN. ALUM
9	END RETENTION GUIDE	NYLON
10a	SIDE RAIL, END RETENTION	6005-T5 ALUM
10b	SIDE RAIL, END RETENTION	6063-T6 ALUM
11	TYPICAL SLAT	6063-T6 ALUM
12	1"x3"x0.125" TUBE	6063-T6 ALUM
13	2"x3"x0.125" TUBE	6063-T6 ALUM
14	2"x4"x0.125" TUBE	6063-T6 ALUM
15	2"x5"x0.125" TUBE	6063-T6 ALUM
16	2"x3"x0.25" TUBE	6061-T6 OR 6005-T5 ALUM
17	2"x4"x0.25" TUBE	6061-T6 OR 6005-T5 ALUM
18	2"x5"x0.25" TUBE	6061-T6 OR 6005-T5 ALUM
19	2"x6"x0.125" TUBE	6063-T6 ALUM
20	2"x6"x0.25" TUBE	6061-T6 OR 6005-T5 ALUM
21	3"x3"x0.125" TUBE	6063-T6 ALUM
22	3"x3"x0.25" TUBE	6061-T6 OR 6005-T5 ALUM
23	4"x4"x0.125" TUBE	6063-T6 ALUM
24	4"x4"x0.25" TUBE	6061-T6 OR 6005-T5 ALUM
25	4"x6"x0.25" TUBE	6061-T6 OR 6005-T5 ALUM
26	4"x8"x0.25" TUBE	6061-T6 OR 6005-T5 ALUM
27	STEEL REINFORCEMENT (F _y = 30 ksi MIN.)	A36 OR STAINLESS STEEL
28	ALUMINUM ANGLE	6061-T6 OR 6005-T5 ALUM
29	OPTIONAL BOTTOM SLAT	6063-T5 ALUM
30	WALL MOUNTED STOP	6063-T6 ALUM

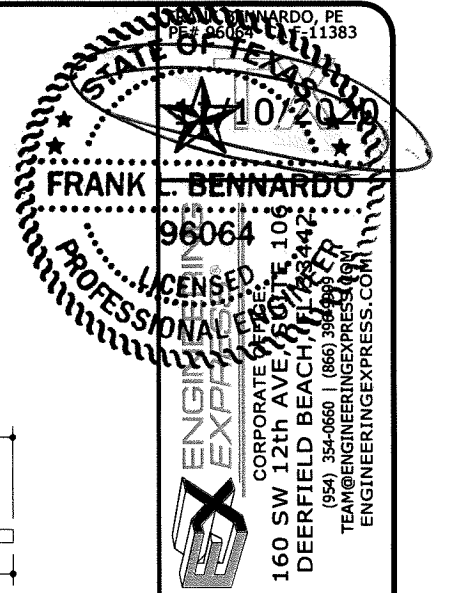

Town & Country INDUSTRIES
Wholesale Aluminum and Building Products
A Division of ABC Supply Co., Inc.
400 WEST MCNAB ROAD
FT. LAUDERDALE, FL 33309

REMARKS	INT. ISSUE	DATE
	KL	4/25/14
	RWN	6/04/14
	RWN	4/08/15
	RWN	8/07/17
	CCB	6/30/20

COPYRIGHT FRANK L. BENNARDO P.E.

20-24244.3a

SCALE: -

PAGE DESCRIPTION: -

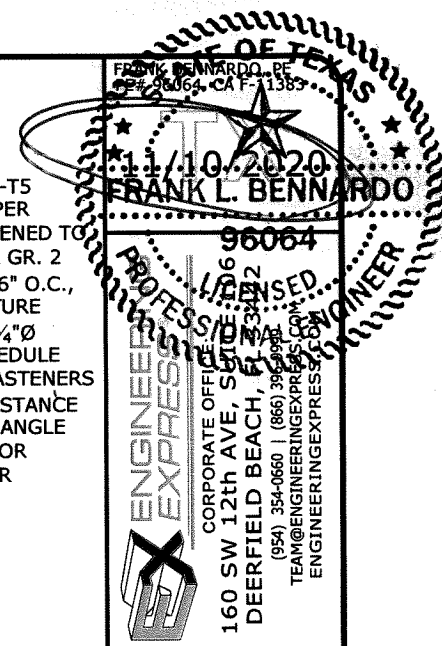

Town & Country
INDUSTRIES
Wholesale Aluminum and Building Products
A Division of A&S Supply Co., Inc.
400 WEST MCNAB ROAD
FT. LAUDERDALE, FL 33309

DRWN	CHKD	DATE
KL	FLB	4/25/14
RWN	TSB	6/04/14
RWN	CSL	4/08/15
RWN	FLB	8/07/17
CCB	RWN	6/30/20

REMARKS:
INIT ISSUE
REV FOR TDH
2014 FBC
2017 FBC
2018 IBC

THIS DOCUMENT IS THE PROPERTY OF FRANK L. BENNARDO, P.E. AND SHALL NOT BE REPRODUCED IN WHOLE OR IN PART WITHOUT WRITTEN CONSENT OF FRANK L. BENNARDO, P.E. PERMISSION IS GRANTED TO MAKE COPIES OF THIS DOCUMENT FOR PERSONAL USE ONLY. PERMISSION IS NOT GRANTED TO REPRODUCE OR TRANSMIT THIS DOCUMENT IN ANY MANNER OR BY ANY MEANS, ELECTRONIC OR MECHANICAL, INCLUDING PHOTOCOPYING, RECORDING, OR BY ANY INFORMATION STORAGE AND RETRIEVAL SYSTEM.

COPYRIGHT FRANK L. BENNARDO P.E.

20-24244.3a

SCALE: -
PAGE DESCRIPTION: -

15

3

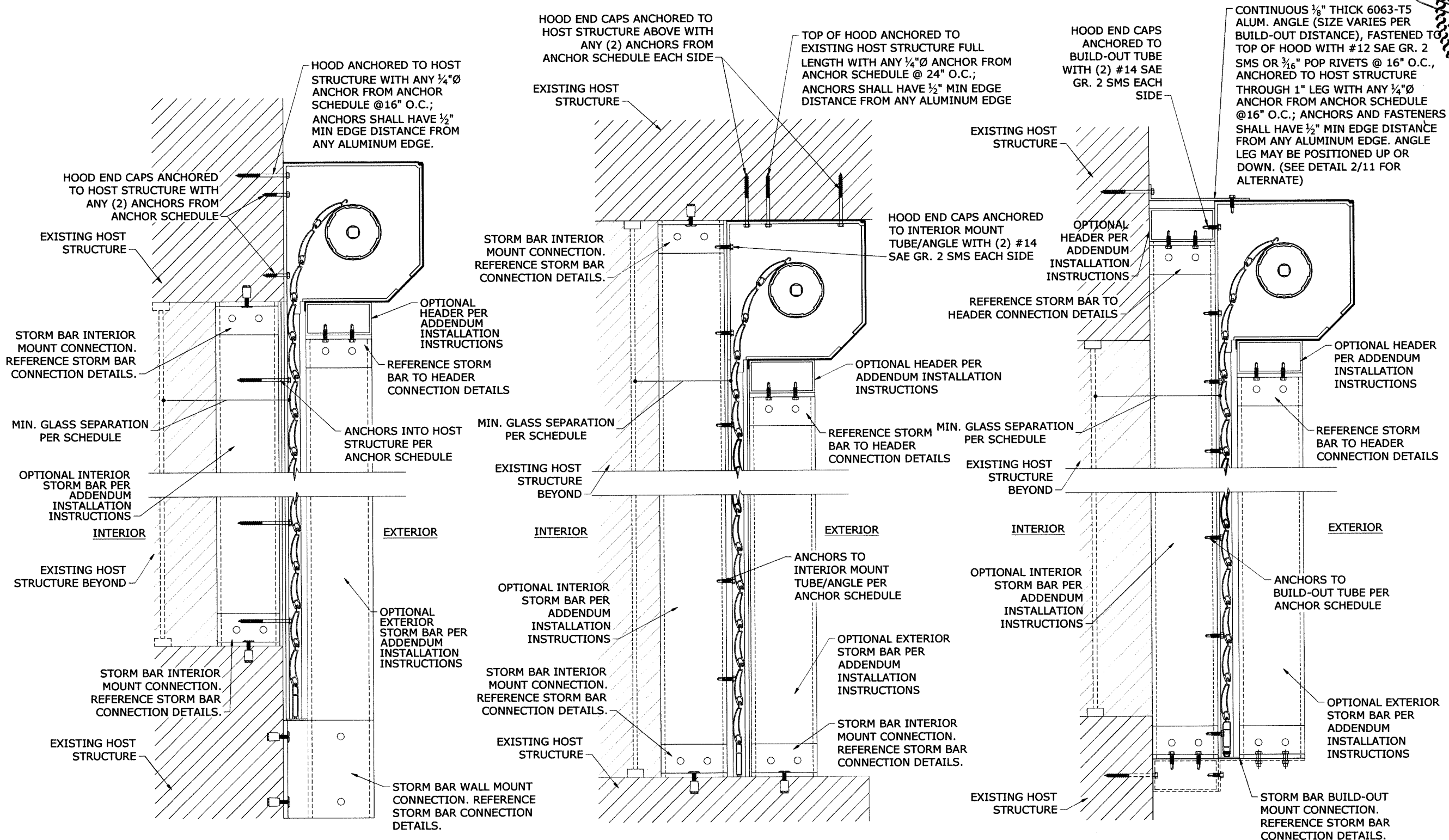

1 WALL MOUNT (SHOWN W/ OPTIONAL STORM BARS)
3 N.T.S. VERT SECTION

NOTE: FOR OPTIONAL MOUNTING CONDITIONS, REFERENCE ADDENDUM STORM BAR AND MULLION INSTALLATION INSTRUCTIONS.

2 INTERIOR MOUNT (SHOWN W/ OPTIONAL STORM BARS)
3 N.T.S. VERT SECTION

NOTE: FOR OPTIONAL MOUNTING CONDITIONS, REFERENCE ADDENDUM STORM BAR AND MULLION INSTALLATION INSTRUCTIONS.

3 BUILD-OUT MOUNT (SHOWN W/ OPTIONAL STORM BARS)
3 N.T.S. VERT SECTION

NOTE: FOR OPTIONAL MOUNTING CONDITIONS, REFERENCE ADDENDUM STORM BAR AND MULLION INSTALLATION INSTRUCTIONS.

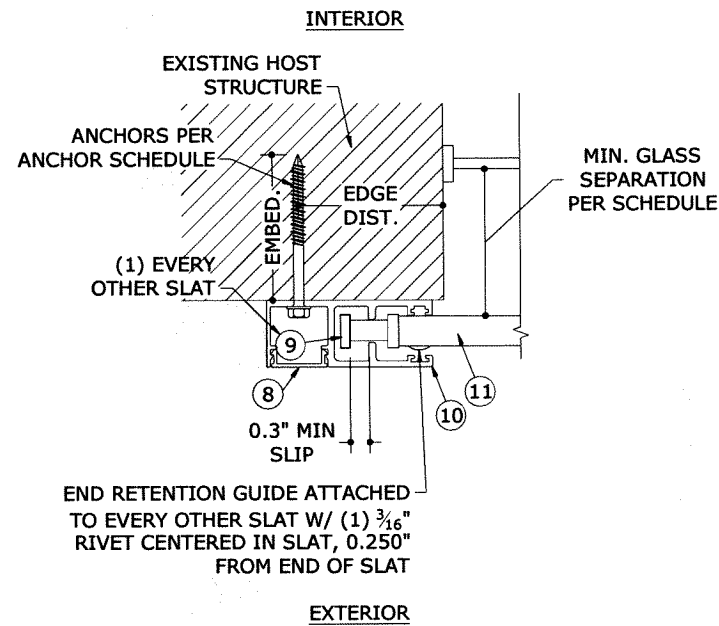

1
4 N.T.S. **END RETENTION TYPICAL WALL MOUNT**
HORIZ SECTION

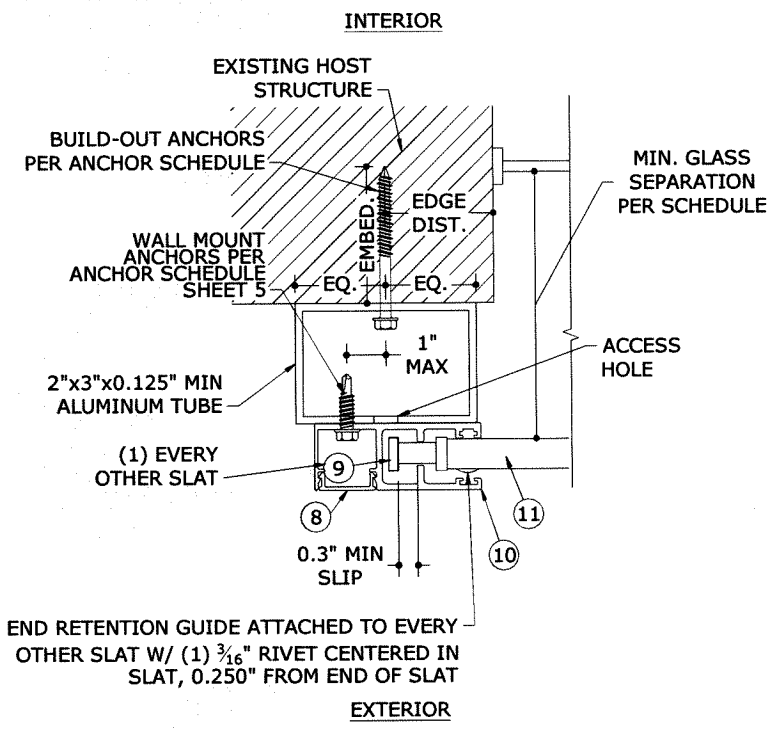

2
4 N.T.S. **END RETENTION TYP. BUILD-OUT MOUNT**
HORIZ SECTION

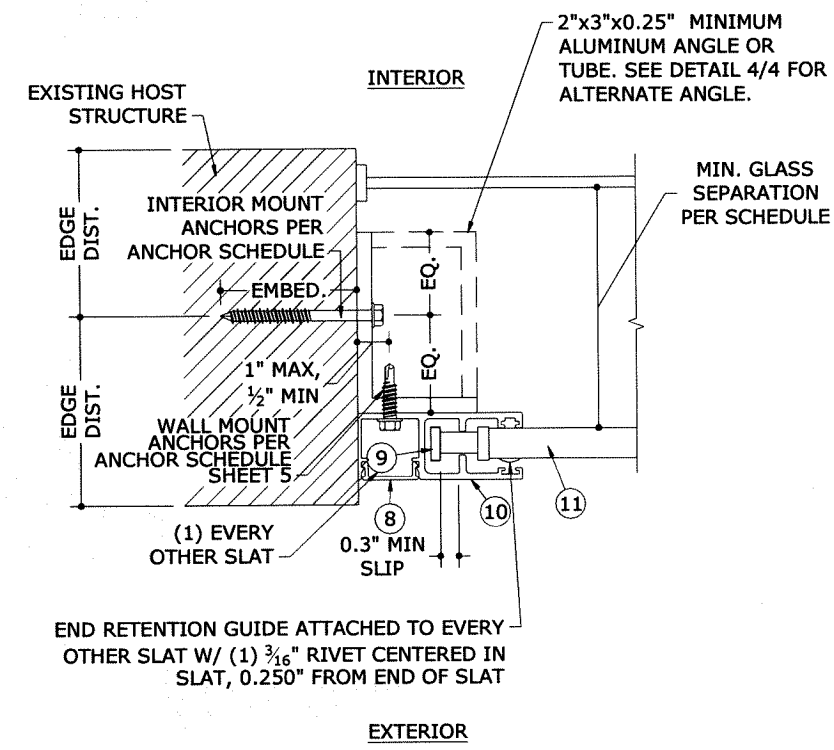

3
4 N.T.S. **END RETENTION TYP. INTERIOR MOUNT**
HORIZ SECTION

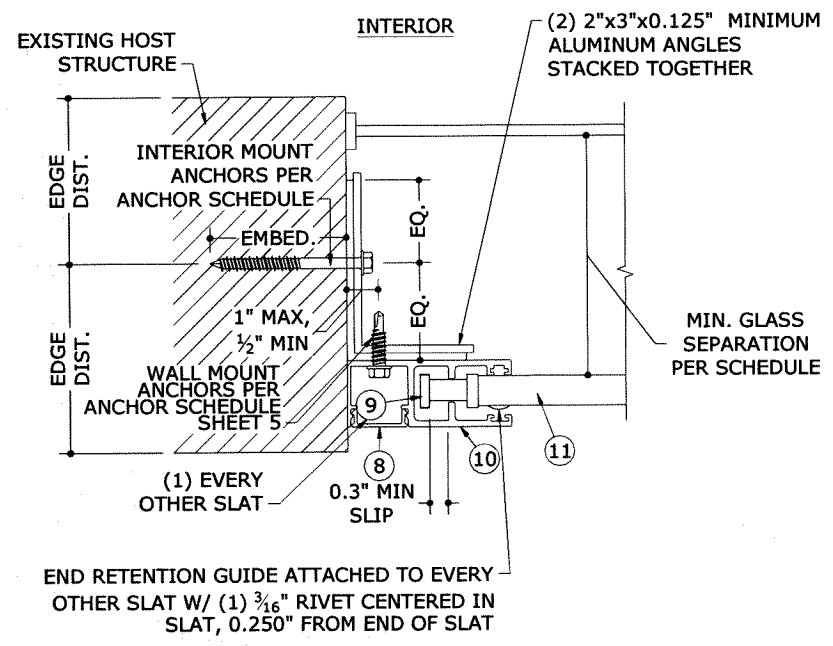

4
4 N.T.S. **END RETENTION TYP. INTERIOR MOUNT**
HORIZ SECTION

ANCHOR NOTES:

1. ANCHORS SHALL BE INSTALLED IN ACCORDANCE WITH MANUFACTURERS' RECOMMENDATIONS.
2. WHERE ANCHORS FASTEN TO NARROW FACE OF STUD FRAMING, ANCHOR SHALL BE LOCATED IN CENTER OF NOMINAL 2x (MIN) WOOD STUD (i.e. 3/4" EDGE DISTANCE IS ACCEPTABLE FOR ANCHORS TO WOOD FRAMING).
3. MINIMUM EMBEDMENT SHALL BE AS NOTED IN ANCHOR SCHEDULE. MINIMUM EMBEDMENT AND EDGE DISTANCE EXCLUDES STUCCO, FOAM, BRICK, AND OTHER WALL FINISHES.
4. ANCHOR SCHEDULE APPLIES TO ALL PRODUCTS CERTIFIED HEREIN, BUT ONLY PROVIDES MAXIMUM ALLOWABLE ANCHOR SPACING. MAXIMUM ALLOWABLE SPANS AND PRESSURES INDICATED IN SPAN SCHEDULE SHALL APPLY.
5. WHERE EXISTING STRUCTURE IS WOOD FRAMING, EXISTING CONDITIONS MAY VARY. FIELD VERIFY THAT FASTENERS ARE INTO ADEQUATE WOOD FRAMING MEMBERS, NOT INTO PLYWOOD. FASTENERS MAY BE INSTALLED THROUGH PLYWOOD PROVIDED THAT THEY ARE FULLY EMBEDDED INTO STRUCTURAL MATERIAL BEYOND.
6. WOOD BUCKS (BY OTHERS) SHALL BE ANCHORED PROPERLY TO TRANSFER LOADS TO THE EXISTING STRUCTURE.
7. MACHINE SCREWS SHALL HAVE MINIMUM OF 1/2" ENGAGEMENT OF THREADS IN BASE ANCHOR AND MAY HAVE EITHER A PAN HEAD, TRUSS HEAD, OR WAFER HEAD ("SIDEWALK BOLT") U.N.O.
8. SHEET METAL SCREWS SHALL BE INSTALLED WITH FULL ENGAGEMENT OF THREADS INTO METAL HOST STRUCTURE.
9. * DESIGNATES ANCHOR CONDITIONS WHICH ARE NOT ACCEPTABLE FOR USE.
10. * ANCHOR SHALL PENETRATE THROUGH FACE SHELL INTO GROUTED CELL.

FRANK L. BENNARDO, PE
PE # 96064
10/2020
FRANK L. BENNARDO
96064
PROFESSIONAL ENGINEER
CORPORATE OFFICE
160 SW 12th Ave, Suite 106
DEERFIELD BEACH, FL 33442
(954) 354-0660 | (866) 394-9959
TEAM@ENGINEERINGEXPRESS.COM
ENGINEERINGEXPRESS.COM

Town & Country
INDUSTRIES
Wholesale Aluminum and Building Products
A Division of ABC Supply Co., Inc.
400 WEST MCNAB ROAD
FT. LAUDERDALE, FL 33309

DRWN	CHKD	DATE
KL	FLB	4/25/14
RWN	TSB	6/04/14
RWN	CSL	4/08/15
RWN	FLB	8/07/17
CCB	RWN	6/30/20

REMARKS
INIT ISSUE
REV FOR TDI
2014 FBC
2017 FBC
2018 IBC

THIS DOCUMENT IS THE PROPERTY OF FRANK L. BENNARDO, P.E. AND SHALL NOT BE REPRODUCED IN WHOLE OR PART WITHOUT WRITTEN CONSENT OF FRANK L. BENNARDO, P.E. ANY UNAUTHORIZED REPRODUCTION OR USE OF THIS DOCUMENT ARE NOT PERMITTED AND WILL BE EVALUATED FOR CERTIFICATION.

COPYRIGHT FRANK L. BENNARDO P.E.

20-24244.3a
SCALE: -
PAGE DESCRIPTION:
OF 15
4

ANCHOR SCHEDULE: END RETENTION INTERIOR MOUNT

MAY BE ANY ANGLE(S)
OR TUBE(S) FROM
DETAILS 3/4 AND 4/4

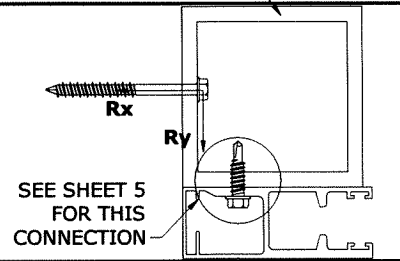

MAXIMUM SPACING (O.C.)

SLAT SPAN	DESIGN PRESSURE	Rx	Ry	MAXIMUM SPACING (O.C.)																								
				1/4" DEWALT ULTRACON TO 2700 PSI MIN. CONCRETE; 1.75" MIN. EMBEDMENT; 2.5" MIN. EDGE DISTANCE	1/4" SS ITW TAPCON TO 3192 PSI MIN. CONCRETE; 1.75" MIN. EMBEDMENT; 2.5" MIN. EDGE DISTANCE	5/16" DEWALT ULTRACON TO 3500 PSI MIN. CONCRETE; 2" MIN. EMBEDMENT; 3.125" MIN. EDGE DISTANCE	5/16" ITW TAPCON		1/4" DEWALT POWER-BOLT TO 3000 PSI MIN. CONCRETE; 2.5" MIN. EMBEDMENT; 3" MIN. EDGE DISTANCE	1/4" ALL-POINTS SOLID-SET		1/4" LAG SCREW TO G=0.55 MIN WOOD; 1.5" MIN. EMBEDMENT; 0.75" MIN. EDGE DISTANCE	5/16" LAG SCREW TO G=0.42 MIN WOOD; 2" MIN. EMBEDMENT; 0.75" MIN. EDGE DISTANCE	#14 WOOD SCREW TO G=0.55 MIN WOOD; 1.5" MIN. EMBEDMENT; 0.75" MIN. EDGE DISTANCE	#14 410 SS SMS W/ FULL THREAD PENETRATION OR 1/4-20 410 SS THRU-BOLT TO 0.125" MIN. 6063-T6 ALUM; 0.5" MIN. EDGE DISTANCE	5/16" 410 SS SMS W/ FULL THREAD PENETRATION OR 5/16-18 410 SS THRU-BOLT TO 0.25" MIN. 6063-T6 ALUM; 0.625" MIN. EDGE DISTANCE	3/8" DEWALT SCREW BOLT TO 3000 PSI MIN. CONCRETE; 3.5" MIN. EMBEDMENT; 4.5" MIN. EDGE DISTANCE	3/8" DEWALT CONFLX										
				TO 2899 PSI MIN. CONCRETE; 2.25" MIN. EMBEDMENT; 4" MIN. EDGE DISTANCE	TO HOLLOW CONCRETE BLOCK; 1.75" MIN. EMBEDMENT; 4" MIN. EDGE DISTANCE		TO 3000 PSI MIN. CONCRETE; 0.875" MIN. EMBEDMENT; 3" MIN. EDGE DISTANCE	TO HOLLOW BLOCK; 0.875" MIN. EMBEDMENT; 3" MIN. EDGE DISTANCE																				
62"	+/- 37.5 PSF	64.6 LB/FT	96.9 LB/FT	8.0"	8.0"	8.0"	8.0"	8.0"	8.0"	8.0"	8.0"	8.0"	8.0"	8.0"	8.0"	8.0"	8.0"	8.0"	8.0"	8.0"	8.0"	8.0"	8.0"	8.0"	8.0"	8.0"	8.0"	8.0"
	+/- 42.1 PSF	72.5 LB/FT	108.8 LB/FT	8.0"	8.0"	8.0"	8.0"	8.0"	8.0"	8.0"	8.0"	8.0"	8.0"	8.0"	8.0"	8.0"	8.0"	8.0"	8.0"	8.0"	8.0"	8.0"	8.0"	8.0"	8.0"	8.0"	8.0"	8.0"
	+/- 46.0 PSF	79.3 LB/FT	118.8 LB/FT	8.0"	8.0"	8.0"	8.0"	8.0"	8.0"	8.0"	8.0"	8.0"	8.0"	8.0"	8.0"	8.0"	8.0"	8.0"	8.0"	8.0"	8.0"	8.0"	8.0"	8.0"	8.0"	8.0"	8.0"	8.0"
	+/- 50.0 PSF	86.2 LB/FT	129.2 LB/FT	8.0"	8.0"	8.0"	8.0"	8.0"	8.0"	8.0"	8.0"	8.0"	8.0"	8.0"	8.0"	8.0"	8.0"	8.0"	8.0"	8.0"	8.0"	8.0"	8.0"	8.0"	8.0"	8.0"	8.0"	8.0"
	+/- 56.4 PSF	97.2 LB/FT	145.7 LB/FT	8.0"	8.0"	8.0"	8.0"	8.0"	8.0"	8.0"	8.0"	8.0"	8.0"	8.0"	8.0"	8.0"	8.0"	8.0"	8.0"	8.0"	8.0"	8.0"	8.0"	8.0"	8.0"	8.0"	8.0"	8.0"
	+/- 68.0 PSF	117.2 LB/FT	175.7 LB/FT	8.0"	8.0"	8.0"	8.0"	8.0"	8.0"	8.0"	8.0"	8.0"	8.0"	8.0"	8.0"	8.0"	8.0"	8.0"	8.0"	8.0"	8.0"	8.0"	8.0"	8.0"	8.0"	8.0"	8.0"	8.0"
72"	+/- 37.5 PSF	75.0 LB/FT	112.5 LB/FT	8.0"	8.0"	8.0"	8.0"	8.0"	8.0"	8.0"	8.0"	8.0"	8.0"	8.0"	8.0"	8.0"	8.0"	8.0"	8.0"	8.0"	8.0"	8.0"	8.0"	8.0"	8.0"	8.0"	8.0"	8.0"
	+/- 42.1 PSF	84.2 LB/FT	126.3 LB/FT	8.0"	8.0"	8.0"	8.0"	8.0"	8.0"	8.0"	8.0"	8.0"	8.0"	8.0"	8.0"	8.0"	8.0"	8.0"	8.0"	8.0"	8.0"	8.0"	8.0"	8.0"	8.0"	8.0"	8.0"	8.0"
	+/- 46.0 PSF	92.0 LB/FT	138.0 LB/FT	8.0"	8.0"	8.0"	8.0"	8.0"	8.0"	8.0"	8.0"	8.0"	8.0"	8.0"	8.0"	8.0"	8.0"	8.0"	8.0"	8.0"	8.0"	8.0"	8.0"	8.0"	8.0"	8.0"	8.0"	8.0"
	+/- 50.0 PSF	100.1 LB/FT	150.0 LB/FT	8.0"	8.0"	8.0"	8.0"	8.0"	8.0"	8.0"	8.0"	8.0"	8.0"	8.0"	8.0"	8.0"	8.0"	8.0"	8.0"	8.0"	8.0"	8.0"	8.0"	8.0"	8.0"	8.0"	8.0"	8.0"
	+/- 56.4 PSF	112.9 LB/FT	169.2 LB/FT	8.0"	8.0"	8.0"	8.0"	8.0"	8.0"	8.0"	8.0"	8.0"	8.0"	8.0"	8.0"	8.0"	8.0"	8.0"	8.0"	8.0"	8.0"	8.0"	8.0"	8.0"	8.0"	8.0"	8.0"	8.0"
	+/- 68.0 PSF	168.1 LB/FT	204.0 LB/FT	8.0"	8.0"	8.0"	8.0"	8.0"	8.0"	8.0"	8.0"	8.0"	8.0"	8.0"	8.0"	8.0"	8.0"	8.0"	8.0"	8.0"	8.0"	8.0"	8.0"	8.0"	8.0"	8.0"	8.0"	8.0"
84"	+/- 37.5 PSF	87.5 LB/FT	131.3 LB/FT	8.0"	8.0"	8.0"	8.0"	8.0"	8.0"	8.0"	8.0"	8.0"	8.0"	8.0"	8.0"	8.0"	8.0"	8.0"	8.0"	8.0"	8.0"	8.0"	8.0"	8.0"	8.0"	8.0"	8.0"	8.0"
	+/- 42.1 PSF	153.5 LB/FT	147.4 LB/FT	8.0"	8.0"	8.0"	8.0"	8.0"	8.0"	8.0"	8.0"	8.0"	8.0"	8.0"	8.0"	8.0"	8.0"	8.0"	8.0"	8.0"	8.0"	8.0"	8.0"	8.0"	8.0"	8.0"	8.0"	8.0"
	+/- 46.0 PSF	213.4 LB/FT	161.0 LB/FT	8.0"	8.0"	8.0"	8.0"	8.0"	8.0"	8.0"	8.0"	8.0"	8.0"	8.0"	8.0"	8.0"	8.0"	8.0"	8.0"	8.0"	8.0"	8.0"	8.0"	8.0"	8.0"	8.0"	8.0"	8.0"
	+/- 50.0 PSF	274.8 LB/FT	175.0 LB/FT	8.0"	8.0"	8.0"	8.0"	8.0"	8.0"	8.0"	8.0"	8.0"	8.0"	8.0"	8.0"	8.0"	8.0"	8.0"	8.0"	8.0"	8.0"	8.0"	8.0"	8.0"	8.0"	8.0"	8.0"	8.0"
	+/- 56.4 PSF	372.9 LB/FT	197.4 LB/FT	8.0"	8.0"	8.0"	8.0"	8.0"	8.0"	8.0"	8.0"	8.0"	8.0"	8.0"	8.0"	8.0"	8.0"	8.0"	8.0"	8.0"	8.0"	8.0"	8.0"	8.0"	8.0"	8.0"	8.0"	8.0"
	+/- 68.0 PSF	550.8 LB/FT	238.0 LB/FT	7.1"	7.9"	8.0"	8.0"	8.0"	8.0"	8.0"	8.0"	8.0"	8.0"	8.0"	8.0"	8.0"	8.0"	8.0"	8.0"	8.0"	8.0"	8.0"	8.0"	8.0"	8.0"	8.0"	8.0"	8.0"
96"	+/- 37.5 PSF	319.1 LB/FT	150.0 LB/FT	8.0"	8.0"	8.0"	8.0"	8.0"	8.0"	8.0"	8.0"	8.0"	8.0"	8.0"	8.0"	8.0"	8.0"	8.0"	8.0"	8.0"	8.0"	8.0"	8.0"	8.0"	8.0"	8.0"	8.0"	8.0"
	+/- 42.1 PSF	404.4 LB/FT	168.4 LB/FT	8.0"	8.0"	8.0"	8.0"	8.0"	8.0"	8.0"	8.0"	8.0"	8.0"	8.0"	8.0"	8.0"	8.0"	8.0"	8.0"	8.0"	8.0"	8.0"	8.0"	8.0"	8.0"	8.0"	8.0"	8.0"
	+/- 46.0 PSF	476.7 LB/FT	184.0 LB/FT	8.0"	8.0"	8.0"	8.0"	8.0"	8.0"	8.0"	8.0"	8.0"	8.0"	8.0"	8.0"	8.0"	8.0"	8.0"	8.0"	8.0"	8.0"	8.0"	8.0"	8.0"	8.0"	8.0"	8.0"	8.0"
	+/- 50.0 PSF	550.8 LB/FT	200.0 LB/FT	7.5"	8.0"	8.0"	8.0"	8.0"	8.0"	8.0"	8.0"	8.0"	8.0"	8.0"	8.0"	8.0"	8.0"	8.0"	8.0"	8.0"	8.0"	8.0"	8.0"	8.0"	8.0"	8.0"	8.0"	8.0"
	+/- 56.4 PSF	689.3 LB/FT	225.6 LB/FT	6.3"	7.1"	8.0"	8.0"	8.0"	8.0"	8.0"	8.0"	8.0"	8.0"	8.0"	8.0"	8.0"	8.0"	8.0"	8.0"	8.0"	8.0"	8.0"	8.0"	8.0"	8.0"	8.0"	8.0"	8.0"
	+/- 68.0 PSF	883.6 LB/FT	272.0 LB/FT	4.9"	5.5"	8.0"	8.0"	8.0"	8.0"	8.0"	8.0"	8.0"	8.0"	8.0"	8.0"	8.0"	8.0"	8.0"	8.0"	8.0"	8.0"	8.0"	8.0"	8.0"	8.0"	8.0"	8.0"	8.0"
108"	+/- 37.5 PSF	526.0 LB/FT	168.8 LB/FT	8.0"	8.0"	8.0"	8.0"	8.0"	8.0"	8.0"	8.0"	8.0"	8.0"	8.0"	8.0"	8.0"	8.0"	8.0"	8.0"	8.0"	8.0"	8.0"	8.0"	8.0"	8.0"	8.0"	8.0"	8.0"
	+/- 42.1 PSF	626.9 LB/FT	189.5 LB/FT	6.9"	7.8"	8.0"	8.0"	8.0"	8.0"	8.0"	8.0"	8.0"	8.0"	8.0"	8.0"	8.0"	8.0"	8.0"	8.0"	8.0"	8.0"	8.0"	8.0"	8.0"	8.0"	8.0"	8.0"	8.0"
	+/- 46.0 PSF	712.4 LB/FT	207.0 LB/FT	6.1"	6.9"	8.0"	8.0"	8.0"	8.0"	8.0"	8.0"	8.0"	8.0"	8.0"	8.0"	8.0"	8.0"	8.0"	8.0"	8.0"	8.0"	8.0"	8.0"	8.0"	8.0"	8.0"	8.0"	8.0"
	+/- 50.0 PSF	799.9 LB/FT	225.0 LB/FT	5.5"	6.2"	8.0"	8.0"	8.0"	8.0"	8.0"	8.0"	8.0"	8.0"	8.0"	8.0"	8.0"	8.0"	8.0"	8.0"	8.0"	8.0"	8.0"	8.0"	8.0"	8.0"	8.0"	8.0"	8.0"
	+/- 56.4 PSF	939.9 LB/FT	253.8 LB/FT	4.7"	5.3"	8.0"	8.0"	8.0"	8.0"	8.0"	8.0"	8.0"	8.0"	8.0"	8.0"	8.0"	8.0"	8.0"	8.0"	8.0"	8.0"	8.0"	8.0"	8.0"	8.0"	8.0"	8.0"	8.0"
	+/- 68.0 PSF	1193.0 LB/FT	306.0 LB/FT	4.2"	4.2"	6.7"	6.4"	5.8"	5.8"	5.8"	5.8"	5.8"	5.8"	5.8"	5.8"	5.8"	5.8"	5.8"	5.8"	5.8"	5.8"	5.8"	5.8"	5.8"	5.8"	5.8"	5.8"	5.8"
120"	+/- 37.5 PSF	716.7 LB/FT	187.5 LB/FT	6.2"	7.0"	8.0"	8.0"	8.0"	8.0"	8.0"	8.0"	8.0"	8.0"	8.0"	8.0"	8.0"	8.0"	8.0"	8.0"	8.0"	8.0"	8.0"	8.0"	8.0"	8.0"	8.0"	8.0"	8.0"
	+/- 42.1 PSF	833.8 LB/FT	210.5 LB/FT	5.4"	6.1"	8.0"	8.0"	8.0"	8.0"	8.0"	8.0"	8.0"	8.0"	8.0"	8.0"	8.0"	8.0"	8.0"	8.0"	8.0"	8.0"	8.0"	8.0"	8.0"	8.0"	8.0"	8.0"	8.0"
	+/- 46.0 PSF	933.0 LB/FT	230.0 LB/FT	4.8"	5.5"	8.0"	8.0"	8.0"	8.0"	8.0"	8.0"	8.0"	8.0"	8.0"	8.0"	8.0"	8.0"	8.0"	8.0"	8.0"	8.0"	8.0"	8.0"	8.0"	8.0"	8.0"	8.0"	8.0"
	+/- 50.0 PSF	1034.5 LB/FT	250.0 LB/FT	4.4"	5.0"	7.8"	7.5"	6.8"	6.8"	6.8"	6.8"	6.8"	6.8"	6.8"	6.8"	6.8"	6.8"	6.8"	6.8"	6.8"	6.8"	6.8"	6.8"	6.8"	6.8"	6.8"	6.8"	6.8"
	+/- 56.4 PSF	1196.8 LB/FT	282.0 LB/FT	4.3"	4.3"	6.8"	6.5"	5.9"	5.9"	5.9"	5.9"	5.9"	5.9"	5.9"	5.9"	5.9"	5.9"	5.9"	5.9"	5.9"	5.9"	5.9"	5.9"	5.9"	5.9"	5.9"	5.9"	5.9"
	+/- 68.0 PSF	1493.0 LB/FT	330.0 LB/FT	3.8"	3.8"	6.0"	5.7"	5.1"	5.1"	5.1"	5.1"	5.1"	5.1"	5.1"	5.1"	5.1"	5.1"	5.1"	5.1"	5.1"	5.1"	5.1"	5.1"	5.1"	5.1"	5.1"	5.1"	5.1"
132"	+/- 37.5 PSF	899.0 LB/FT	206.3 LB/FT	5.1"	5.8"	8.0"	8.0"	8.0"	8.0"	8.0"	8.0"	8.0"	8.0"	8.0"	8.0"	8.0"	8.0"	8.0"	8.0"	8.0"	8.0"	8.0"	8.0"	8.0"	8.0"	8.0"	8.0"	8.0"
	+/- 42.1 PSF	1033.0 LB/FT	231.6 LB/FT	4.5"	5.0"	8.0"	8.0"	8.0"	8.0"	8.0"	8.0"	8.0"	8.0"	8.0"	8.0"	8.0"	8.0"	8.0"	8.0"	8.0"	8.0"	8.0"	8.0"	8.0"	8.0"	8.0"	8.0"	8.0"
	+/- 46.0 PSF	1146.5 LB/FT	253.0 LB/FT	4.0"	4.6"	7.2"	6.8"	6.2"	6.2"	6.2"	6.2"	6.2"	6.2"	6.2"	6.2"	6.2"	6.2"	6.2"	6.2"	6.2"	6.2"	6.2"	6.2"	6.2"	6.2"	6.2"	6.2"	6.2"
146.5"	+/- 37.5 PSF	1114.0 LB/FT	228.9 LB/FT	4.2"	4.8"	7.1"	7.1"	6.5"	6.5"	6.5"	6.5"	6.5"	6.5"	6.5"	6.5"	6.5"	6.5"	6.5"	6.5"	6.5"	6.5"	6.5"	6.5"	6.5"	6.5"	6.5"	6.5"	6.5"
	+/- 46.0 PSF	1401.1 LB/FT	280.8 LB/FT	4.2"	4.2"	6.0"	5.7"	5.2"	5.2"	5.2"	5.2"	5.2"	5.2"	5.2"	5.2"	5.2"	5.2"	5.2"	5.2"	5.2"	5.2"	5.2"	5.2"	5.2"	5.2"	5.2"	5.2"	5.2"

ANCHOR NOTES: SEE SHEET 4 FOR ANCHOR NOTES.

FRANK L. BENNARDO, P.E.
11/10/2028
PROFESSIONAL ENGINEER
CORPORATE OFFICE
160 SW 12th AVE, SUITE 600
DEERFIELD BEACH, FL 33442
(954) 354-0660 | (866) 396-6999
TEAM@ENGINEERINGEXPRESS.COM
ENGINEERINGEXPRESS.COM

Town & Country
INDUSTRIES
Wholesale Aluminum and Building Products
A Division of Alco Supply Co., Inc.
400 WEST MCNAB ROAD
FT. LAUDERDALE, FL 33309

DRWN	CHKD	DATE
KL	FLB	4/25/14
RWN	TSS	6/04/14
RWN	CSL	4/08/15
RWN	FLB	8/07/17
CCB	RWN	6/30/20

REMARKS:
INIT ISSUE
REV FOR TDI
2014 FBC
2017 FBC
2018 IBC

THIS DOCUMENT IS THE PROPERTY OF FRANK L. BENNARDO, P.E. AND SHALL NOT BE REPRODUCED IN WHOLE OR PART WITHOUT WRITTEN CONSENT OF FRANK L. BENNARDO, P.E. - ALL REVISIONS, ADDITIONS, DELETIONS OR OTHER MARKINGS TO THIS DOCUMENT ARE NOT PERMITTED AND INVALID FOR CONSTRUCTION.

COPYRIGHT FRANK L. BENNARDO P.E.
20-24244.3a
SCALE: -
PAGE DESCRIPTION:

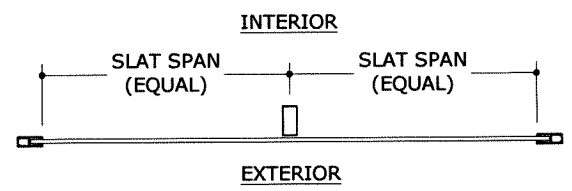
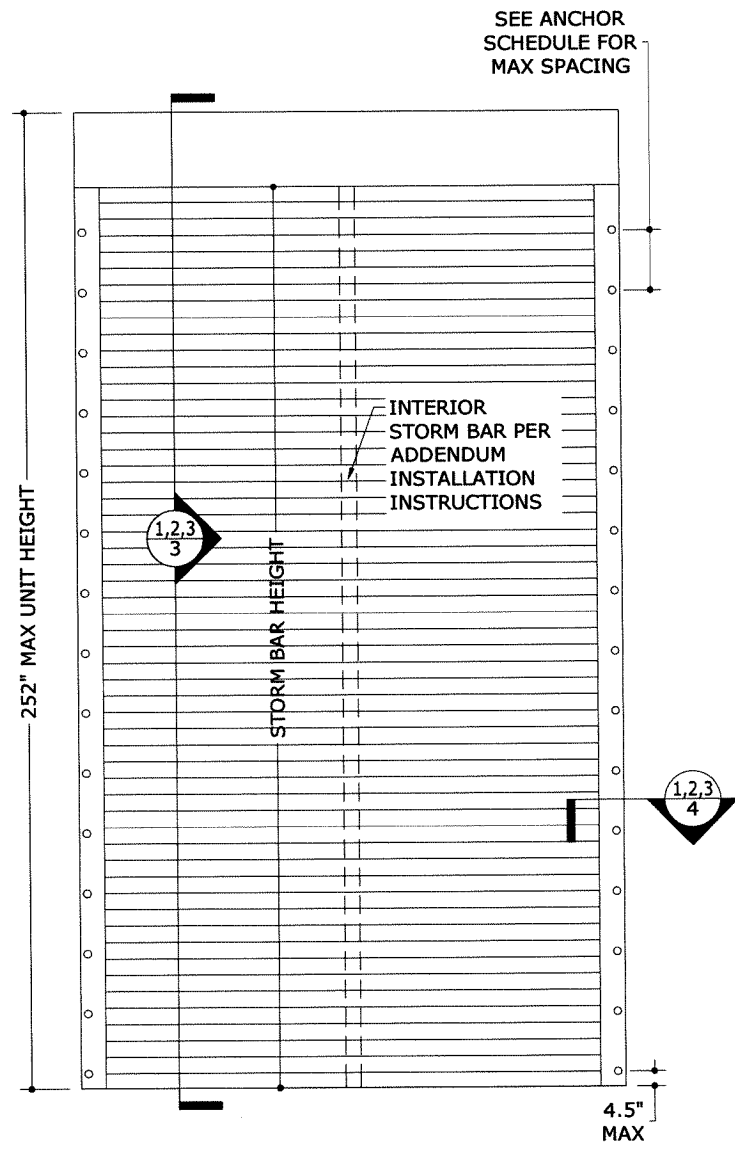
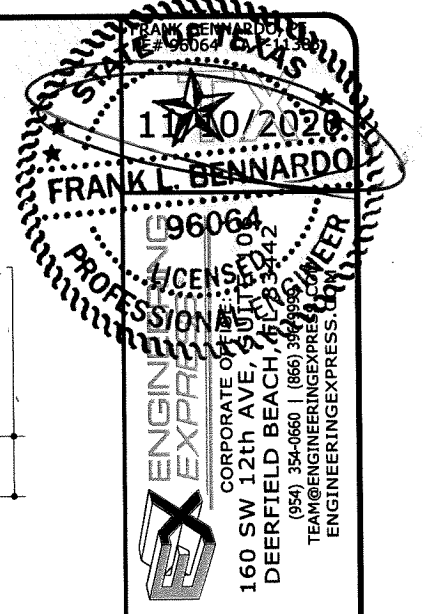

1
8
END RETENTION SHUTTER WITH INTERIOR STORM BARS (DOUBLE-SPAN)
N.T.S. EXTERIOR ELEV

TABLE 3 MINIMUM GLAZING SEPARATION END-RETENTION SHUTTER WITH INTERIOR STORM BARS (ESSENTIAL FACILITIES ONLY)				
SLAT SPAN	SPAN TYPE	POSITIVE DESIGN PRESSURE	INSTALLATIONS ≤ 30' ABOVE GRADE	INSTALLATIONS > 30' ABOVE GRADE
48.5"	DOUBLE SPAN	+ 30 PSF	4.5"	3.3"
		+ 40 PSF	4.5"	3.3"
		+ 50 PSF	4.5"	3.3"
		+ 60 PSF	4.5"	3.3"
		+ 70 PSF	4.5"	3.3"
55.0"	DOUBLE SPAN	+ 30 PSF	4.5"	3.5"
		+ 40 PSF	4.5"	3.5"
		+ 50 PSF	4.5"	3.5"
		+ 60 PSF	4.5"	3.5"
		+ 70 PSF	4.5"	3.5"
36.7"	DOUBLE SPAN	+ 30 PSF	4.5"	2.7"
		+ 40 PSF	4.5"	2.7"
		+ 50 PSF	4.5"	2.7"
		+ 60 PSF	4.5"	2.7"
		+ 70 PSF	4.5"	2.7"
44.0"	TRIPLE SPAN	+ 30 PSF	4.5"	2.8"
		+ 40 PSF	4.5"	2.8"
		+ 50 PSF	4.5"	2.8"
		+ 60 PSF	4.5"	2.8"
		+ 70 PSF	4.5"	2.8"
48.7"	TRIPLE SPAN	+ 30 PSF	4.5"	2.9"
		+ 40 PSF	4.5"	2.9"
		+ 50 PSF	4.5"	2.9"
		+ 60 PSF	4.5"	2.9"
		+ 70 PSF	4.5"	2.9"

TABLE 3 NOTES:

- SLAT SPAN IS DEFINED IN DETAILS 1/8 AND 2/8
- SEPARATION FROM GLAZING IS REQUIRED **ONLY** IN ESSENTIAL FACILITIES.
- LINEAR INTERPOLATION BETWEEN SHUTTER SPANS IS NOT PERMITTED. FOR SPANS BETWEEN THOSE INDICATED ABOVE, THE SEPARATION FROM GLASS FOR THE NEXT HIGHER SPAN SHALL BE USED.

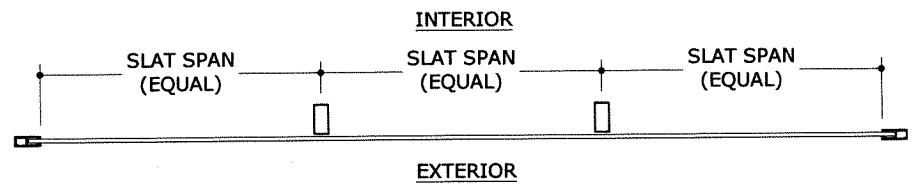
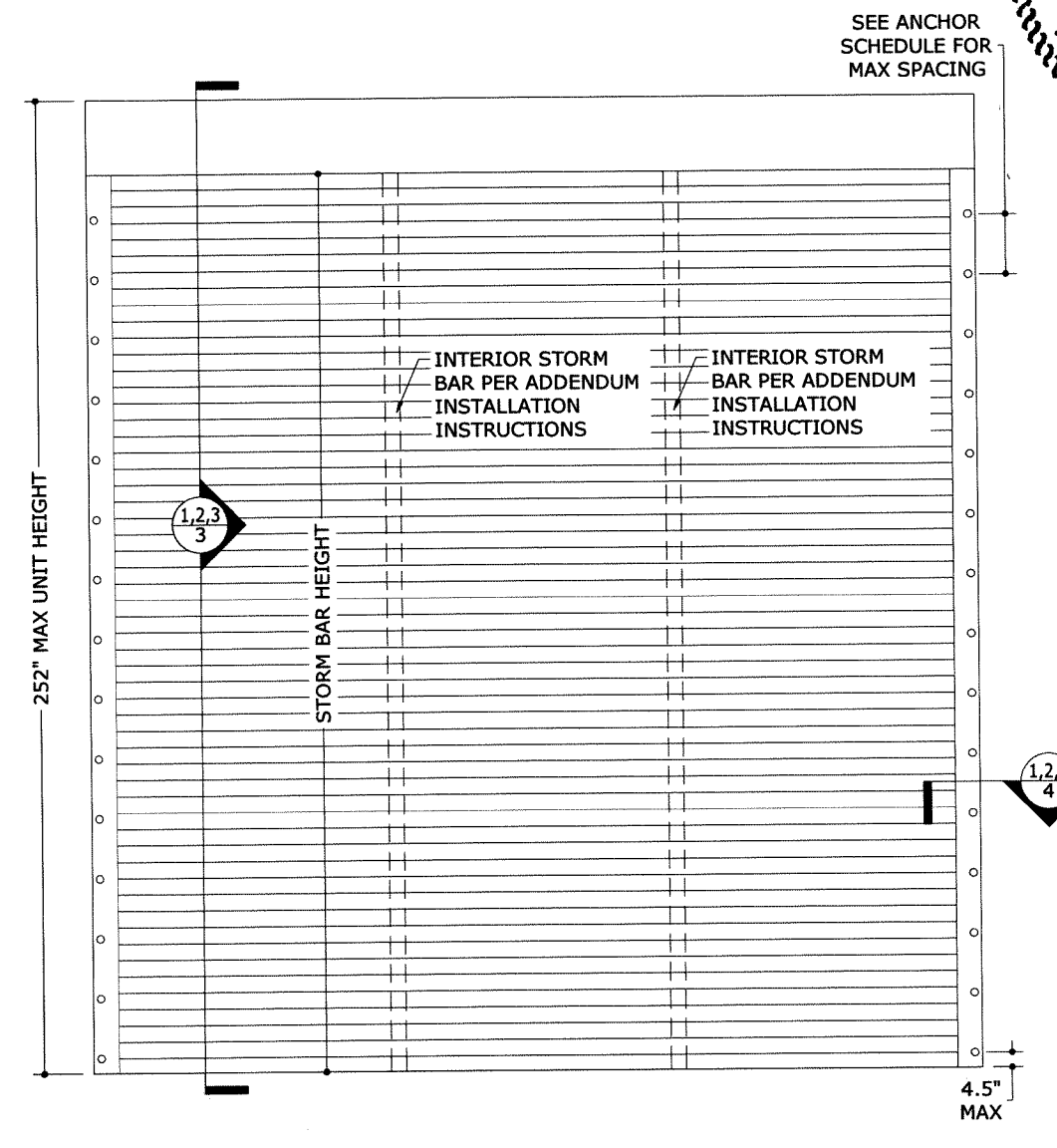

2
8
END RETENTION SHUTTER WITH INTERIOR STORM BARS (TRIPLE-SPAN)
N.T.S. EXTERIOR ELEV

Town & Country
INDUSTRIES
Wholesale Aluminum and Building Products
A Division of ABC Supply Co., Inc.
400 WEST MCNAB ROAD
FT. LAUDERDALE, FL 33309

DRWN	CHKD	DATE
KL	FLB	4/25/14
RWN	TSB	6/04/14
RWN	CSL	4/08/15
RWN	FLB	8/07/17
CCB	RWN	6/30/20

REMARKS:
INIT ISSUE
REV FOR TDI
2014 FBC
2017 FBC
2018 FBC

THIS DOCUMENT IS THE PROPERTY OF FRANK L. BENNARDO, P.E. AND SHALL NOT BE REPRODUCED IN WHOLE OR PART WITHOUT WRITTEN CONSENT OF FRANK L. BENNARDO, P.E. ALTERATIONS, ADDITIONS, HIGHLIGHTS, OR OTHER MARKINGS TO THIS DOCUMENT ARE NOT PERMITTED AND INVALIDATE OUR CONTRIBUTION.

COPYRIGHT FRANK L. BENNARDO P.E.

20-24244.3a
SCALE:
PAGE DESCRIPTION:

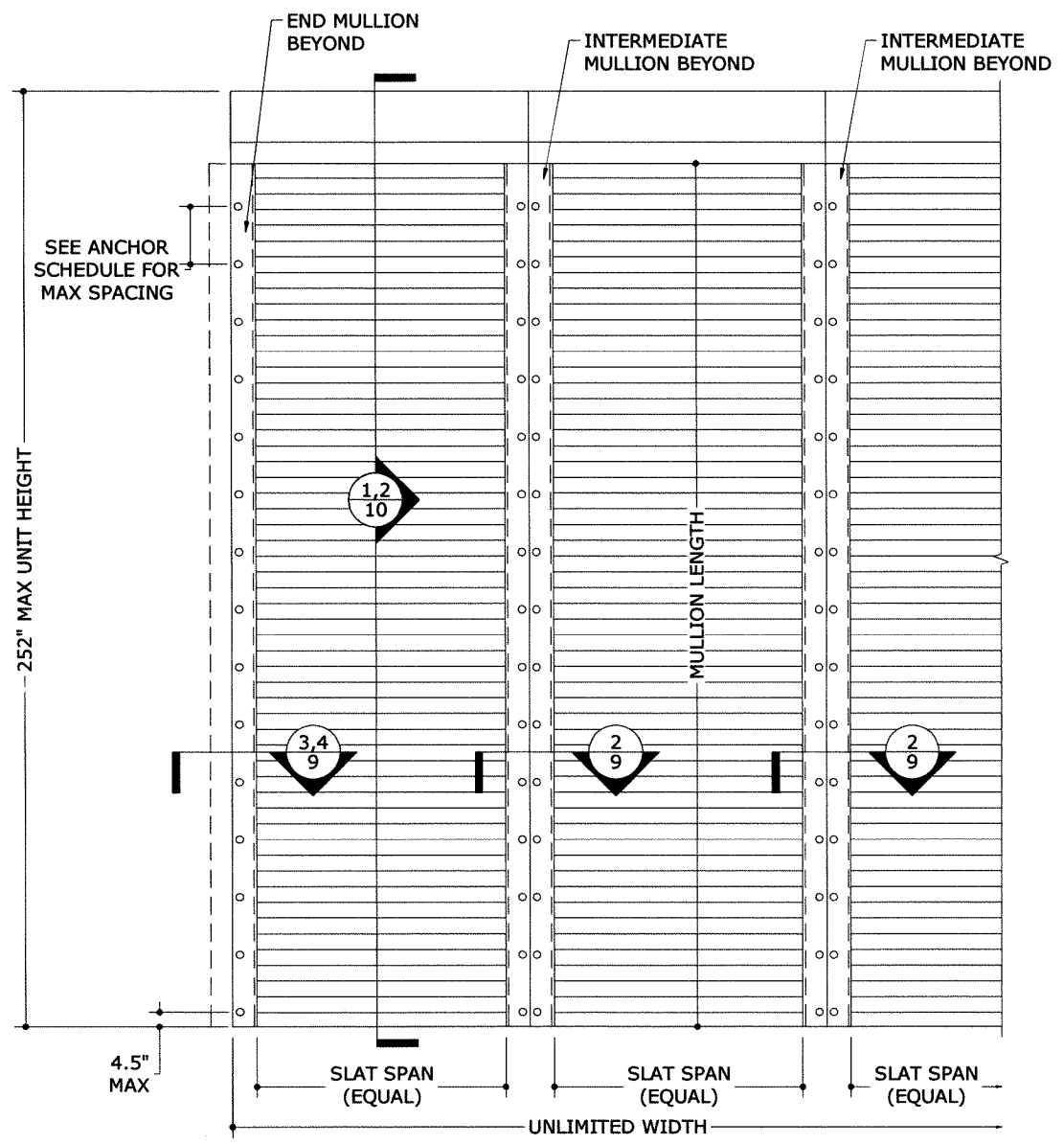

1
9 N.T.S. **TYPICAL SHUTTER WITH MULLIONS**
EXTERIOR ELEV

NOTE: MULLIONS PER MULLION SCHEDULES.

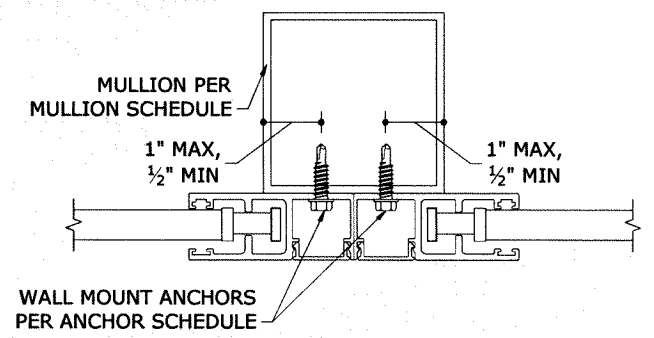

2
9 N.T.S. **WALL MOUNT TO INTERMEDIATE MULLION**
HORIZ SECTION

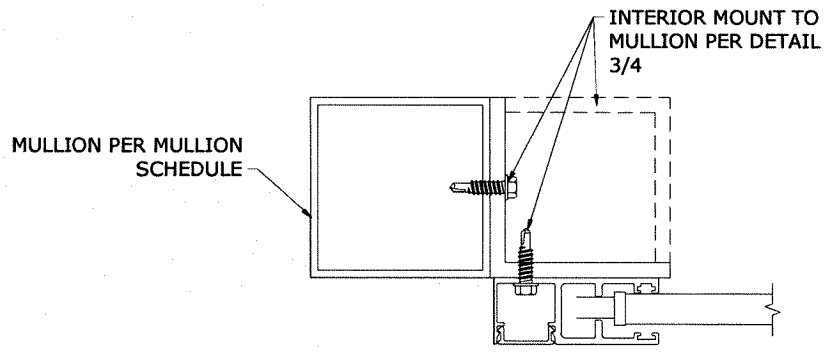

3
9 N.T.S. **INTERIOR MOUNT TO END MULLION**
HORIZ SECTION

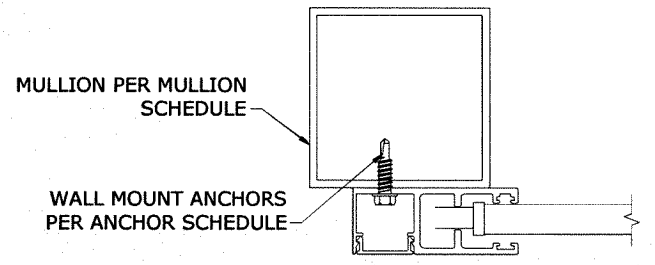

4
9 N.T.S. **WALL MOUNT TO END MULLION**
HORIZ SECTION

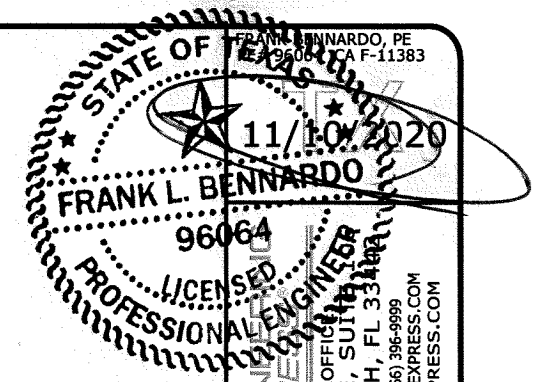

ENGINEERING EXPRESS
CORPORATE OFFICE
160 SW 12th AVE, SUITE 200
DEERFIELD BEACH, FL 33441
(954) 354-0660 | (866) 396-9999
TEAM@ENGINEERINGEXPRESS.COM
ENGINEERINGEXPRESS.COM

Town & Country
INDUSTRIES
A Division of Adco Supply Co., Inc.
Wholesale Aluminum and Building Products
400 WEST MCNAB ROAD
FT. LAUDERDALE, FL 33309

DRWN	CHKD	DATE
KL	FLB	4/25/14
RWN	TSB	6/04/14
RWN	CSL	4/08/15
RWN	FLB	8/07/17
CCB	RWN	6/30/20

REMARKS
INIT ISSUE
REV FOR TDI
2014 FBC
2017 FBC
2018 IBC

THIS DOCUMENT IS THE PROPERTY OF FRANK L. BENNARDO, P.E. AND SHALL NOT BE REPRODUCED IN WHOLE OR PART WITHOUT WRITTEN CONSENT OF FRANK L. BENNARDO, P.E. ANY UNAUTHORIZED REPRODUCTION OR DISTRIBUTION OF THIS DOCUMENT ARE NOT PERMITTED AND WILL INVADE OUR PATENT RIGHTS.

COPYRIGHT FRANK L. BENNARDO P.E.
20-24244.3a
SCALE: -
PAGE DESCRIPTION:

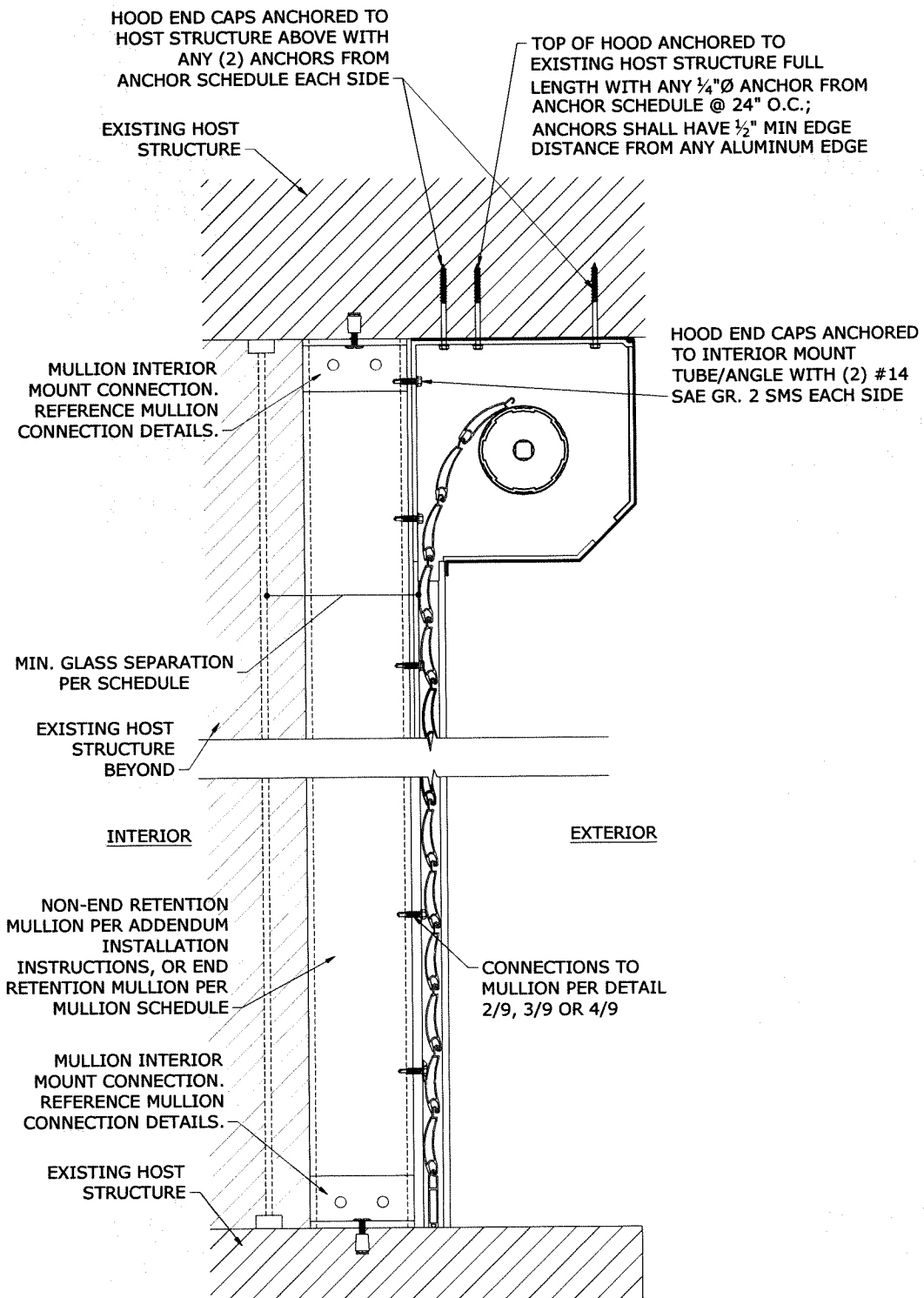

1 MULLION INTERIOR MOUNT
 10 N.T.S. VERT SECTION

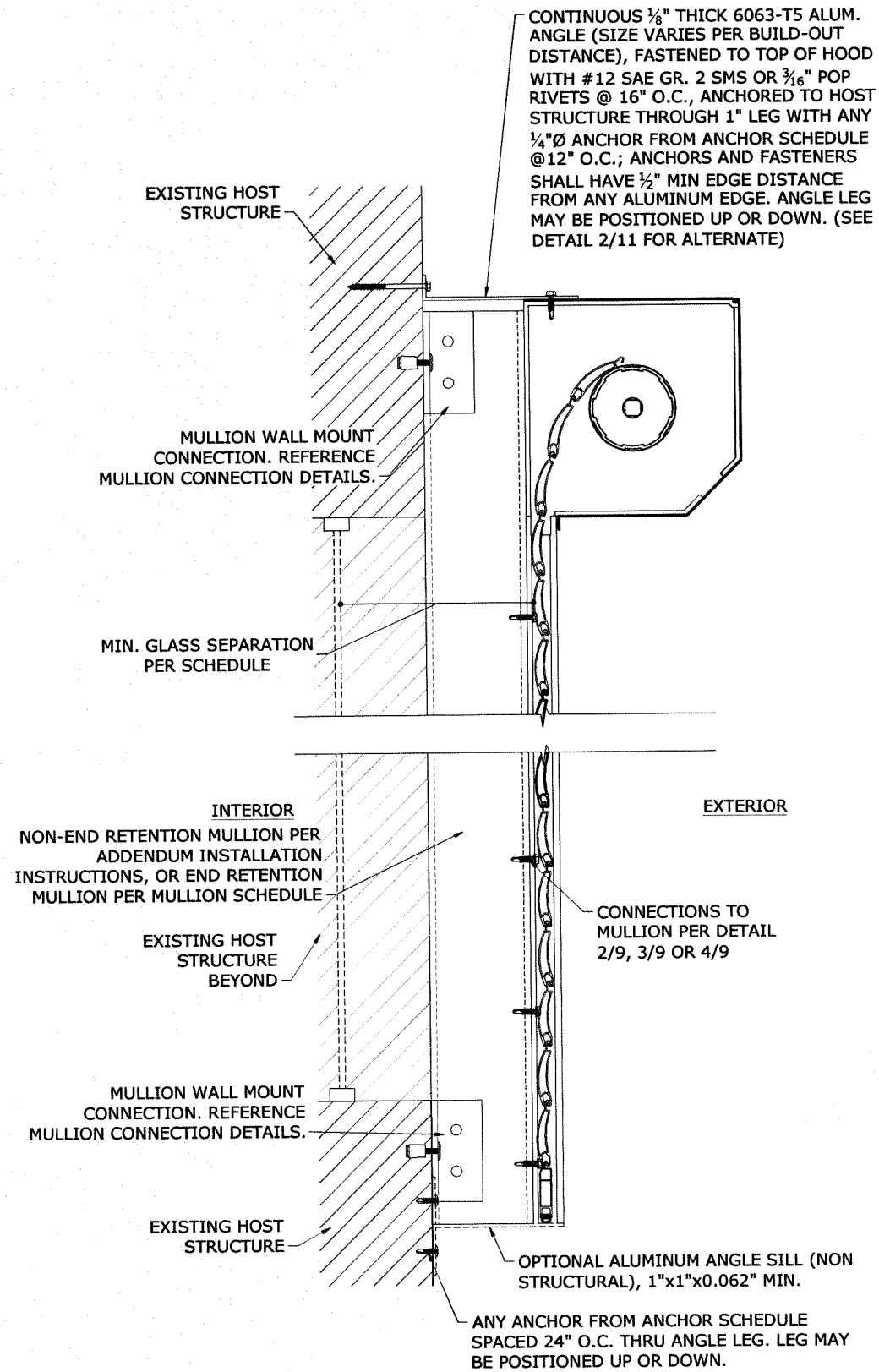

2 MULLION WALL MOUNT
 10 N.T.S. VERT SECTION

FRANK L. BENNARDO, P.E.
 No. 11383
 1/10/2020
 FRANK L. BENNARDO
 96064
 LICENSED PROFESSIONAL ENGINEER
 ENGINEERING EXPRESS, INC.
 CORPORATE OFFICE
 160 SW 12th AVE, SUITE 105
 DEERFIELD BEACH, FL 33442
 (954) 354-0660 | (866) 396-9999
 TEAM@ENGINEERINGEXPRESS.COM
 ENGINEERINGEXPRESS.COM

Town & Country
 INDUSTRIES
 Wholesale Aluminum and Building Products
 A Division of FSC Supply Co., Inc.
 400 WEST MCNAB ROAD
 FT. LAUDERDALE, FL 33309

DRWN	CHKD	DATE
KL	FLB	4/25/14
RWN	TSB	6/04/14
RWN	CSL	4/08/15
RWN	FLB	8/07/17
CCB	RWN	6/30/20

REMARKS
 INT. ISSUE
 REV FOR TDI
 2014 FBC
 2017 FBC
 2018 BC

THIS DOCUMENT IS THE PROPERTY OF FRANK L. BENNARDO, P.E. AND SHALL NOT BE REPRODUCED IN WHOLE OR PART WITHOUT WRITTEN CONSENT OF FRANK L. BENNARDO, P.E. ALTERNATIONS, ADDITIONS, DELETIONS, OR OMISSIONS TO THIS DOCUMENT ARE NOT PERMITTED AND WILL VOID OUR CERTIFICATION.

COPYRIGHT FRANK L. BENNARDO P.E.

20-24244.3a

SCALE: -

PAGE DESCRIPTION: -

OF 15

END RETENTION MULLION SCHEDULE: INTERMEDIATE MULLIONS

SLAT SPAN	DESIGN PRESSURE	3"x3"x0.125"		3"x3"x0.125" W/ 2.75"x2.75"x1/8" STEEL REINF.*		3"x3"x0.25"		4"x4"x0.125"		4"x4"x0.125" W/ 3.75"x3.75"x1/8" STEEL REINF.*		4"x4"x0.25"		4"x6"x0.25"		4"x8"x0.25"	
		MAX MULLION LENGTH	END REACTION Rt	MAX MULLION LENGTH	END REACTION Rt	MAX MULLION LENGTH	END REACTION Rt	MAX MULLION LENGTH	END REACTION Rt	MAX MULLION LENGTH	END REACTION Rt	MAX MULLION LENGTH	END REACTION Rt	MAX MULLION LENGTH	END REACTION Rt	MAX MULLION LENGTH	END REACTION Rt
62"	+/- 38 PSF	102.4"	826.6 LB	113.4"	915.2 LB	120.0"	968.8 LB	120.0"	968.8 LB	120.0"	968.8 LB	120.0"	968.8 LB	120.0"	968.8 LB	120.0"	968.8 LB
	+/- 42 PSF	98.5"	892.8 LB	109.1"	988.6 LB	118.2"	1071.0 LB	120.0"	1087.6 LB	120.0"	1087.6 LB	120.0"	1087.6 LB	120.0"	1087.6 LB	120.0"	1087.6 LB
	+/- 46 PSF	95.6"	947.2 LB	105.9"	1048.7 LB	114.7"	1136.2 LB	120.0"	1188.3 LB	120.0"	1188.3 LB	120.0"	1188.3 LB	120.0"	1188.3 LB	120.0"	1188.3 LB
	+/- 50 PSF	93.0"	1001.3 LB	103.0"	1108.6 LB	111.6"	1201.1 LB	120.0"	1291.7 LB	120.0"	1291.7 LB	120.0"	1291.7 LB	120.0"	1291.7 LB	120.0"	1291.7 LB
	+/- 56 PSF	89.4"	1085.0 LB	98.9"	1201.3 LB	107.2"	1301.6 LB	115.3"	1399.7 LB	120.0"	1457.0 LB	120.0"	1457.0 LB	120.0"	1457.0 LB	120.0"	1457.0 LB
	+/- 68 PSF	84.0"	1229.1 LB	93.0"	1360.9 LB	100.7"	1474.4 LB	108.3"	1585.6 LB	120.0"	1756.7 LB	120.0"	1756.7 LB	120.0"	1756.7 LB	120.0"	1756.7 LB
	+/- 76 PSF	80.9"	1323.7 LB	89.6"	1465.6 LB	97.1"	1587.9 LB	104.4"	1707.6 LB	120.0"	1963.3 LB	120.0"	1963.3 LB	120.0"	1963.3 LB	120.0"	1963.3 LB
72"	+/- 42 PSF	93.7"	986.4 LB	103.8"	1092.2 LB	112.4"	1183.3 LB	120.0"	1263.0 LB	120.0"	1263.0 LB	120.0"	1263.0 LB	120.0"	1263.0 LB	120.0"	1263.0 LB
	+/- 46 PSF	91.0"	1046.4 LB	100.8"	1158.6 LB	109.2"	1255.3 LB	117.4"	1349.9 LB	120.0"	1380.0 LB	120.0"	1380.0 LB	120.0"	1380.0 LB	120.0"	1380.0 LB
	+/- 50 PSF	88.5"	1106.3 LB	98.0"	1224.9 LB	106.2"	1327.0 LB	114.2"	1427.1 LB	120.0"	1500.0 LB	120.0"	1500.0 LB	120.0"	1500.0 LB	120.0"	1500.0 LB
	+/- 56 PSF	85.0"	1198.8 LB	94.1"	1327.3 LB	102.0"	1438.0 LB	109.7"	1546.4 LB	120.0"	1692.0 LB	120.0"	1692.0 LB	120.0"	1692.0 LB	120.0"	1692.0 LB
	+/- 68 PSF	79.9"	1358.0 LB	88.4"	1503.5 LB	95.8"	1629.0 LB	103.0"	1751.8 LB	119.3"	2028.9 LB	120.0"	2040.0 LB	120.0"	2040.0 LB	120.0"	2040.0 LB
	+/- 76 PSF	77.0"	1462.5 LB	85.2"	1619.3 LB	92.3"	1754.3 LB	99.3"	1886.6 LB	115.0"	2185.1 LB	119.5"	2270.4 LB	120.0"	2280.0 LB	120.0"	2280.0 LB
	+/- 38 PSF	92.5"	1012.0 LB	102.4"	1120.5 LB	111.0"	1214.0 LB	119.4"	1305.6 LB	120.0"	1312.5 LB	120.0"	1312.5 LB	120.0"	1312.5 LB	120.0"	1312.5 LB
84"	+/- 42 PSF	89.0"	1093.2 LB	98.6"	1210.4 LB	106.8"	1311.4 LB	114.8"	1410.3 LB	120.0"	1473.5 LB	120.0"	1473.5 LB	120.0"	1473.5 LB	120.0"	1473.5 LB
	+/- 46 PSF	86.4"	1159.7 LB	95.7"	1284.0 LB	103.7"	1391.1 LB	111.5"	1496.1 LB	120.0"	1610.0 LB	120.0"	1610.0 LB	120.0"	1610.0 LB	120.0"	1610.0 LB
	+/- 50 PSF	84.1"	1226.0 LB	93.1"	1357.4 LB	100.8"	1470.7 LB	108.5"	1581.6 LB	120.0"	1750.0 LB	120.0"	1750.0 LB	120.0"	1750.0 LB	120.0"	1750.0 LB
	+/- 56 PSF	80.8"	1328.5 LB	89.4"	1470.9 LB	96.9"	1593.6 LB	104.2"	1713.8 LB	120.0"	1974.0 LB	120.0"	1974.0 LB	120.0"	1974.0 LB	120.0"	1974.0 LB
	+/- 68 PSF	75.9"	1504.9 LB	84.0"	1666.3 LB	91.0"	1805.3 LB	97.9"	1941.4 LB	113.4"	2248.5 LB	117.8"	2336.3 LB	120.0"	2380.0 LB	120.0"	2380.0 LB
	+/- 76 PSF	73.1"	1620.8 LB	81.0"	1794.5 LB	87.7"	1944.2 LB	94.3"	2090.8 LB	109.2"	2421.6 LB	113.5"	2516.1 LB	120.0"	2660.0 LB	120.0"	2660.0 LB
	+/- 38 PSF	88.5"	1106.3 LB	98.0"	1224.9 LB	106.2"	1327.0 LB	114.2"	1427.1 LB	120.0"	1500.0 LB	120.0"	1500.0 LB	120.0"	1500.0 LB	120.0"	1500.0 LB
96"	+/- 42 PSF	85.2"	1195.0 LB	94.3"	1323.1 LB	102.1"	1433.5 LB	109.8"	1541.6 LB	120.0"	1684.0 LB	120.0"	1684.0 LB	120.0"	1684.0 LB	120.0"	1684.0 LB
	+/- 46 PSF	82.7"	1267.7 LB	91.5"	1403.6 LB	99.2"	1520.7 LB	106.7"	1635.3 LB	120.0"	1840.0 LB	120.0"	1840.0 LB	120.0"	1840.0 LB	120.0"	1840.0 LB
	+/- 50 PSF	80.4"	1340.1 LB	89.0"	1483.8 LB	96.5"	1607.6 LB	103.7"	1728.8 LB	120.0"	2000.0 LB	120.0"	2000.0 LB	120.0"	2000.0 LB	120.0"	2000.0 LB
	+/- 56 PSF	77.2"	1452.2 LB	85.5"	1607.9 LB	92.7"	1742.0 LB	99.6"	1873.4 LB	115.4"	2169.7 LB	119.9"	2254.4 LB	120.0"	2256.0 LB	120.0"	2256.0 LB
	+/- 68 PSF	72.6"	1645.0 LB	80.4"	1821.4 LB	87.1"	1973.3 LB	93.6"	2122.2 LB	108.4"	2457.8 LB	112.7"	2553.8 LB	120.0"	2720.0 LB	120.0"	2720.0 LB
	+/- 38 PSF	85.1"	1196.6 LB	94.2"	1324.9 LB	102.1"	1435.4 LB	109.8"	1543.7 LB	120.0"	1687.5 LB	120.0"	1687.5 LB	120.0"	1687.5 LB	120.0"	1687.5 LB
	+/- 42 PSF	81.9"	1292.6 LB	90.7"	1431.2 LB	98.2"	1550.5 LB	105.6"	1667.5 LB	120.0"	1894.5 LB	120.0"	1894.5 LB	120.0"	1894.5 LB	120.0"	1894.5 LB
108"	+/- 46 PSF	79.5"	1371.2 LB	88.0"	1518.2 LB	95.4"	1644.9 LB	102.5"	1768.9 LB	118.8"	2048.7 LB	120.0"	2070.0 LB	120.0"	2070.0 LB	120.0"	2070.0 LB
	+/- 50 PSF	77.3"	1449.6 LB	85.6"	1605.0 LB	92.7"	1738.9 LB	99.7"	1870.0 LB	115.5"	2165.8 LB	120.0"	2250.0 LB	120.0"	2250.0 LB	120.0"	2250.0 LB
	+/- 56 PSF	74.3"	1570.8 LB	82.2"	1739.2 LB	89.1"	1884.3 LB	95.8"	2026.4 LB	111.0"	2346.9 LB	115.3"	2438.6 LB	120.0"	2538.0 LB	120.0"	2538.0 LB
	+/- 68 PSF	69.8"	1779.4 LB	77.3"	1970.2 LB	83.7"	2134.5 LB	90.0"	2295.5 LB	104.3"	2658.6 LB	108.3"	2762.4 LB	120.0"	3060.0 LB	120.0"	3060.0 LB
	+/- 38 PSF	82.2"	1283.7 LB	91.0"	1421.3 LB	98.6"	1539.9 LB	106.0"	1656.0 LB	120.0"	1875.0 LB	120.0"	1875.0 LB	120.0"	1875.0 LB	120.0"	1875.0 LB
	+/- 42 PSF	79.0"	1386.6 LB	87.5"	1535.3 LB	94.8"	1663.4 LB	102.0"	1788.8 LB	118.1"	2071.8 LB	120.0"	2105.0 LB	120.0"	2105.0 LB	120.0"	2105.0 LB
	+/- 46 PSF	76.7"	1471.0 LB	85.0"	1628.7 LB	92.1"	1764.6 LB	99.0"	1897.6 LB	114.7"	2197.8 LB	119.1"	2283.7 LB	120.0"	2300.0 LB	120.0"	2300.0 LB
120"	+/- 50 PSF	74.6"	1555.1 LB	82.6"	1721.8 LB	89.5"	1865.4 LB	96.3"	2006.1 LB	111.5"	2323.4 LB	115.9"	2414.2 LB	120.0"	2500.0 LB	120.0"	2500.0 LB
	+/- 56 PSF	71.7"	1685.8 LB	79.4"	1865.8 LB	86.0"	2021.4 LB	92.5"	2173.9 LB	107.1"	2517.7 LB	111.3"	2616.1 LB	120.0"	2820.0 LB	120.0"	2820.0 LB
	+/- 68 PSF	67.4"	1908.9 LB	74.6"	2113.5 LB	80.8"	2289.9 LB	86.9"	2462.5 LB	100.7"	2852.1 LB	104.6"	2963.5 LB	120.0"	3400.0 LB	120.0"	3400.0 LB
	+/- 38 PSF	79.6"	1367.9 LB	88.1"	1514.6 LB	95.5"	1640.9 LB	102.7"	1764.7 LB	118.9"	2043.8 LB	120.0"	2062.5 LB	120.0"	2062.5 LB	120.0"	2062.5 LB
	+/- 42 PSF	76.3"	1477.6 LB	84.8"	1636.0 LB	91.9"	1772.5 LB	98.8"	1906.2 LB	114.4"	2207.7 LB	118.9"	2293.9 LB	120.0"	2315.5 LB	120.0"	2315.5 LB
	+/- 46 PSF	74.3"	1567.5 LB	82.3"	1735.6 LB	89.2"	1880.3 LB	95.9"	2022.1 LB	111.1"	2342.0 LB	115.4"	2433.5 LB	120.0"	2530.0 LB	120.0"	2530.0 LB
	+/- 50 PSF	72.3"	1657.1 LB	80.1"	1834.8 LB	86.7"	1987.8 LB	93.3"	2137.7 LB	108.0"	2475.9 LB	112.3"	2572.6 LB	120.0"	2750.0 LB	120.0"	2750.0 LB
132"	+/- 56 PSF	69.5"	1795.7 LB	76.9"	1988.2 LB	83.3"	2154.0 LB	89.6"	2316.5 LB	103.8"	2682.9 LB	107.8"	2787.7 LB	120.0"	3102.0 LB	120.0"	3102.0 LB
	+/- 38 PSF	76.8"	1469.7 LB	85.0"	1627.2 LB	92.1"	1763.0 LB	99.1"	1895.9 LB	114.7"	2195.8 LB	119.2"	2281.6 LB	120.0"	2296.9 LB	120.0"	2296.9 LB
	+/- 42 PSF	73.5"	1605.4 LB	81.3"	1777.5 LB	88.1"	1925.8 LB	94.8"	2071.0 LB	109.8"	2398.6 LB	114.1"	2492.3 LB	120.0"	2622.2 LB	120.0"	2622.2 LB
	+/- 46 PSF	70.6"	1736.9 LB	78.2"	1923.1 LB	84.7"	2083.6 LB	91.1"	2240.7 LB	105.5"	2595.1 LB	109.6"	2696.5 LB	120.0"	2951.0 LB	120.0"	2951.0 LB
	+/- 50 PSF	68.0"	1871.9 LB	75.3"	2072.6 LB	81.6"	2245.5 LB	87.8"	2414.8 LB	101.7"	2796.8 LB	105.6"	2906.0 LB	120.0"	3301.6 LB	120.0"	3301.6 LB
	+/- 56 PSF	63.9"	2073.0 LB	71.3"	2312.2 LB	77.3"	2505.1 LB	83.0"	2690.4 LB	96.2"	3120.1 LB	100.0"	3242.0 LB	120.0"	3890.5 LB	120.0"	3890.5 LB

***NOTE:** STEEL REINFORCEMENT LENGTH SHALL BE A MINIMUM OF 90% THE MULLION LENGTH, LOCATED AT THE CENTER OF THE MULLION AND FASTENED IN PLACE WITH #14 18-8 SS OR COATED SAE GR. 5 STAINLESS STEEL SMS OR SDS AT 12" O.C. MAX STAGGERED ALONG THE FULL REINFORCEMENT LENGTH. (REFERENCE STEEL REINFORCEMENT DETAIL 1/)

STEEL REINFORCEMENT, 90% OF THE MULLION LENGTH, MINIMUM. LOCATED AT CENTER OF MULLION.

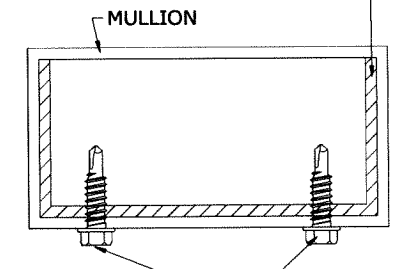

#14 18-8 SS OR COATED SAE GR. 5 STEEL SMS OR SDS AT 12" O.C. MAX STAGGERED FOR FULL LENGTH OF REINFORCEMENT

1 TYPICAL REINFORCEMENT SECTION
11 N.T.S.

CONTINUOUS 1/8" THICK 6063-T5 ALUM. ANGLES (SIZE VARIES PER BUILD-OUT DISTANCE)
ANGLE ANCHORED THRU 1" LEG W/ ANY 1/4" Ø ANCHOR FROM ANCHOR SCHEDULE @16" O.C., 1/2" MIN EDGE DIST. FROM ANY ALUM EDGE
(2) ROWS OF 1/4" 18-8 SS OR COATED SAE GR. 5 STEEL THRU BOLTS, 16" O.C.

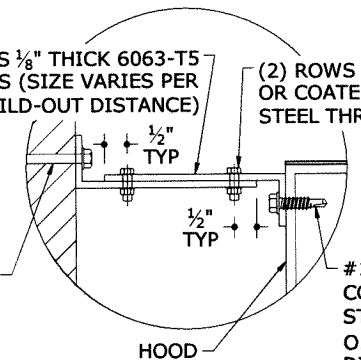

2 ALTERNATE BUILD-OUT HOOD CONNECTION SECTION
11 N.T.S.

END RETENTION MULLION SCHEDULE NOTES:

- PRESSURES SHOWN IN "END RETENTION MULLION SCHEDULE" ARE MAXIMUM ALLOWABLE MULLION LENGTHS AT EACH RESPECTIVE SLAT SPAN AND DESIGN PRESSURE.
- "END RETENTION MULLION SCHEDULES" ARE APPLICABLE TO ALL END RETENTION MULLIONS.
- "INTERMEDIATE MULLIONS" ARE AS DEFINED IN ELEVATION 1/9.
- SEE BILL OF MATERIALS FOR MULLION AND REINFORCEMENT MATERIALS.
- ALLOWABLE DESIGN PRESSURES AND SLAT SPANS INDICATED ARE FOR DETERMINING PERMISSIBLE MULLION LENGTHS ONLY. ACTUAL SLAT SPANS AND DESIGN PRESSURES SHALL NOT EXCEED THOSE INDICATED IN SPAN SCHEDULES.
- "END REACTIONS" ARE LISTED FOR EACH COMBINATION OF DESIGN LOAD, MULLION TYPE, & SLAT SPAN. CHOOSE MOUNTING CONNECTIONS (PER APPLICABLE CONNECTION DETAILS HEREIN) THAT PROVIDES "CONNECTION CAPACITY" GREATER THAN OR EQUAL TO "END REACTIONS" GIVEN ABOVE.
- THIS SCHEDULE MAY BE USED FOR ALL MOUNTING CONDITIONS LISTED HEREIN.
- /// DENOTES CONDITIONS NOT APPROVED FOR USE.

FRANK BERNARDO, PE
PE# 96064 CA F-11383

STATE OF TEXAS
10/2020

FRANK L. BERNARDO
PROFESSIONAL ENGINEER
CORPORATE OFFICE: 9610 BURNING TREE DRIVE, SUITE 300
160 SW 12th AVE, FT. LAUDERDALE, FL 33309
(954) 354-0660 (866) 354-0999
TEAM@ENGINEERINGPROFESSIONALS.COM
ENGINEERINGPROFESSIONALS.COM

Town & Country
INDUSTRIES
Wholesale Aluminum and Building Products
A Division of ABC Supply Co., Inc.

400 WEST MCNAB ROAD
FT. LAUDERDALE, FL 33309

REMARKS	DRWN	CHKD	DATE
INIT ISSUE	KL	FLB	4/25/14
REV FOR TDI	RWN	TSB	6/04/14
2014 FBC	RWN	CSL	4/08/15
2017 FBC	RWN	FLB	8/07/17
2018 IBC	CCB	RWN	6/30/20

THIS DOCUMENT IS THE PROPERTY OF FRANK L. BERNARDO, P.E. AND SHALL NOT BE REPRODUCED IN WHOLE OR PART WITHOUT WRITTEN CONSENT OF FRANK L. BERNARDO, P.E. - ALTERATIONS, ADDITIONS, DELETIONS, OR OTHER MARKINGS TO THIS DOCUMENT ARE NOT PERMITTED AND INVALIDATE OUR CERTIFICATION.

COPYRIGHT FRANK L. BERNARDO P.E.

20-24244.3a

SCALE: -

PAGE DESCRIPTION:

11

END RETENTION MULLION SCHEDULE: END MULLIONS

SLAT SPAN	DESIGN PRESSURE	3"x3"x0.125" W/ 2.75"x2.75"x1/8" STEEL REINF.*				3"x3"x0.25"				4"x4"x0.125" W/ 3.75"x3.75"x1/8" STEEL REINF.*				4"x4"x0.25"				4"x6"x0.25"				4"x8"x0.25"			
		MAX MULLION LENGTH	END REACTION Rv	END REACTION Rt	END REACTION Rsum	MAX MULLION LENGTH	END REACTION Rv	END REACTION Rt	END REACTION Rsum	MAX MULLION LENGTH	END REACTION Rv	END REACTION Rt	END REACTION Rsum	MAX MULLION LENGTH	END REACTION Rv	END REACTION Rt	END REACTION Rsum	MAX MULLION LENGTH	END REACTION Rv	END REACTION Rt	END REACTION Rsum	MAX MULLION LENGTH	END REACTION Rv	END REACTION Rt	END REACTION Rsum
62"	+/- 38 PSF	120.0"	0.0 LB	484.4 LB	484.4 LB	120.0"	0.0 LB	484.4 LB	484.4 LB	120.0"	0.0 LB	484.4 LB	484.4 LB	120.0"	0.0 LB	484.4 LB	484.4 LB	120.0"	0.0 LB	484.4 LB	484.4 LB	120.0"	0.0 LB	484.4 LB	484.4 LB
	+/- 42 PSF	120.0"	133.1 LB	543.8 LB	559.8 LB	120.0"	133.1 LB	543.8 LB	559.8 LB	120.0"	133.1 LB	543.8 LB	559.8 LB	120.0"	133.1 LB	543.8 LB	559.8 LB	120.0"	133.1 LB	543.8 LB	559.8 LB	120.0"	133.1 LB	543.8 LB	559.8 LB
	+/- 46 PSF	120.0"	293.6 LB	594.2 LB	662.8 LB	120.0"	293.6 LB	594.2 LB	662.8 LB	120.0"	293.6 LB	594.2 LB	662.8 LB	120.0"	293.6 LB	594.2 LB	662.8 LB	120.0"	293.6 LB	594.2 LB	662.8 LB	120.0"	293.6 LB	594.2 LB	662.8 LB
	+/- 50 PSF	117.2"	447.7 LB	630.8 LB	773.5 LB	120.0"	458.3 LB	645.8 LB	791.9 LB	120.0"	458.3 LB	645.8 LB	791.9 LB	120.0"	458.3 LB	645.8 LB	791.9 LB	120.0"	458.3 LB	645.8 LB	791.9 LB	120.0"	458.3 LB	645.8 LB	791.9 LB
	+/- 56 PSF	109.4"	658.2 LB	664.1 LB	935.0 LB	120.0"	722.0 LB	728.5 LB	1025.7 LB	120.0"	722.0 LB	728.5 LB	1025.7 LB	120.0"	722.0 LB	728.5 LB	1025.7 LB	120.0"	722.0 LB	728.5 LB	1025.7 LB	120.0"	722.0 LB	728.5 LB	1025.7 LB
	+/- 68 PSF	92.1"	920.8 LB	673.8 LB	1141.0 LB	120.0"	1200.3 LB	878.3 LB	1487.4 LB	120.0"	1200.3 LB	878.3 LB	1487.4 LB	120.0"	1200.3 LB	878.3 LB	1487.4 LB	120.0"	1200.3 LB	878.3 LB	1487.4 LB	120.0"	1200.3 LB	878.3 LB	1487.4 LB
72"	+/- 42 PSF	104.7"	860.1 LB	550.8 LB	1021.3 LB	120.0"	986.1 LB	631.5 LB	1171.0 LB	120.0"	986.1 LB	631.5 LB	1171.0 LB	120.0"	986.1 LB	631.5 LB	1171.0 LB	120.0"	986.1 LB	631.5 LB	1171.0 LB	120.0"	986.1 LB	631.5 LB	1171.0 LB
	+/- 46 PSF	97.3"	964.1 LB	559.6 LB	1114.8 LB	120.0"	1188.7 LB	690.0 LB	1374.5 LB	120.0"	1188.7 LB	690.0 LB	1374.5 LB	120.0"	1188.7 LB	690.0 LB	1374.5 LB	120.0"	1188.7 LB	690.0 LB	1374.5 LB	120.0"	1188.7 LB	690.0 LB	1374.5 LB
	+/- 50 PSF	91.2"	1061.6 LB	570.0 LB	1204.9 LB	119.9"	1357.7 LB	749.5 LB	1584.2 LB	120.0"	1396.7 LB	750.0 LB	1585.4 LB	120.0"	1396.7 LB	750.0 LB	1585.4 LB	120.0"	1396.7 LB	750.0 LB	1585.4 LB	120.0"	1396.7 LB	750.0 LB	1585.4 LB
	+/- 56 PSF	83.4"	1202.7 LB	588.1 LB	1338.8 LB	109.5"	1578.7 LB	772.0 LB	1757.3 LB	116.2"	1675.1 LB	819.1 LB	1864.7 LB	120.0"	1730.1 LB	846.0 LB	1925.9 LB	120.0"	1730.1 LB	846.0 LB	1925.9 LB	120.0"	1730.1 LB	846.0 LB	1925.9 LB
	+/- 68 PSF	73.3"	1426.1 LB	622.7 LB	1556.1 LB	96.0"	1868.1 LB	815.7 LB	2038.4 LB	105.1"	2046.3 LB	893.6 LB	2232.9 LB	119.4"	2324.8 LB	1015.2 LB	2536.8 LB	120.0"	2335.8 LB	1020.0 LB	2548.8 LB	120.0"	2335.8 LB	1020.0 LB	2548.8 LB
	+/- 76 PSF	68.1"	1562.8 LB	646.7 LB	1691.3 LB	89.1"	2045.3 LB	846.4 LB	2213.5 LB	97.7"	2242.9 LB	928.2 LB	2427.4 LB	113.0"	2595.0 LB	1073.9 LB	2808.4 LB	120.0"	2754.7 LB	1140.0 LB	2981.3 LB	120.0"	2754.7 LB	1140.0 LB	2981.3 LB
84"	+/- 38 PSF	90.1"	1175.3 LB	492.9 LB	1274.5 LB	118.0"	1538.5 LB	645.2 LB	1668.3 LB	120.0"	1564.9 LB	656.3 LB	1697.0 LB	120.0"	1564.9 LB	656.3 LB	1697.0 LB	120.0"	1564.9 LB	656.3 LB	1697.0 LB	120.0"	1564.9 LB	656.3 LB	1697.0 LB
	+/- 42 PSF	83.4"	1295.1 LB	512.0 LB	1392.6 LB	109.0"	1693.7 LB	669.5 LB	1821.3 LB	113.3"	1760.4 LB	695.9 LB	1892.9 LB	120.0"	1863.8 LB	736.8 LB	2004.1 LB	120.0"	1863.8 LB	736.8 LB	2004.1 LB	120.0"	1863.8 LB	736.8 LB	2004.1 LB
	+/- 46 PSF	78.7"	1388.9 LB	528.1 LB	1485.9 LB	102.9"	1815.2 LB	690.2 LB	1942.0 LB	108.6"	1916.5 LB	728.7 LB	2050.3 LB	120.0"	2117.1 LB	805.0 LB	2265.0 LB	120.0"	2117.1 LB	805.0 LB	2265.0 LB	120.0"	2117.1 LB	805.0 LB	2265.0 LB
	+/- 50 PSF	74.7"	1479.0 LB	544.5 LB	1576.0 LB	97.5"	1931.9 LB	711.2 LB	2058.7 LB	104.5"	2070.1 LB	762.1 LB	2206.0 LB	118.7"	2351.9 LB	865.8 LB	2506.2 LB	120.0"	2376.8 LB	875.0 LB	2532.7 LB	120.0"	2376.8 LB	875.0 LB	2532.7 LB
	+/- 56 PSF	69.3"	1612.9 LB	570.1 LB	1710.7 LB	90.5"	2105.5 LB	744.3 LB	2233.1 LB	99.0"	2303.0 LB	814.1 LB	2442.6 LB	112.5"	2618.4 LB	925.6 LB	2777.2 LB	120.0"	2792.1 LB	987.0 LB	2961.4 LB	120.0"	2792.1 LB	987.0 LB	2961.4 LB
	+/- 68 PSF	62.0"	1830.9 LB	614.7 LB	1931.4 LB	80.9"	2388.2 LB	801.8 LB	2519.2 LB	88.4"	2610.1 LB	876.4 LB	2753.3 LB	103.9"	3069.8 LB	1030.7 LB	3238.2 LB	111.3"	3288.0 LB	1103.9 LB	3468.4 LB	117.8"	3480.5 LB	1168.6 LB	3671.5 LB
96"	+/- 38 PSF	77.2"	1485.0 LB	482.3 LB	1561.3 LB	100.6"	1936.0 LB	628.7 LB	2035.5 LB	105.5"	2030.9 LB	659.5 LB	2135.3 LB	119.9"	2307.3 LB	749.3 LB	2425.9 LB	120.0"	2309.5 LB	750.0 LB	2428.2 LB	120.0"	2309.5 LB	750.0 LB	2428.2 LB
	+/- 42 PSF	72.0"	1604.6 LB	505.3 LB	1682.3 LB	93.8"	2090.9 LB	658.5 LB	2192.2 LB	100.5"	2239.1 LB	705.2 LB	2347.5 LB	114.2"	2543.8 LB	801.1 LB	2667.0 LB	120.0"	2673.6 LB	842.0 LB	2803.1 LB	120.0"	2673.6 LB	842.0 LB	2803.1 LB
	+/- 46 PSF	68.4"	1699.4 LB	524.3 LB	1778.4 LB	89.1"	2213.8 LB	683.0 LB	2316.8 LB	96.9"	2408.2 LB	742.9 LB	2520.2 LB	110.1"	2735.9 LB	844.0 LB	2863.1 LB	117.9"	2930.4 LB	904.0 LB	3066.7 LB	120.0"	2982.1 LB	920.0 LB	3120.8 LB
	+/- 50 PSF	65.2"	1791.4 LB	543.1 LB	1871.9 LB	84.9"	2333.0 LB	707.4 LB	2437.9 LB	92.6"	2545.9 LB	771.9 LB	2660.4 LB	106.5"	2926.0 LB	887.1 LB	3057.5 LB	114.0"	3134.0 LB	950.2 LB	3274.9 LB	120.0"	3298.2 LB	1000.0 LB	3446.5 LB
	+/- 56 PSF	60.9"	1929.3 LB	572.2 LB	2012.4 LB	79.3"	2511.9 LB	745.0 LB	2620.0 LB	86.5"	2740.2 LB	812.7 LB	2858.2 LB	101.5"	3217.6 LB	954.3 LB	3356.1 LB	108.7"	3446.3 LB	1022.1 LB	3594.7 LB	115.1"	3648.2 LB	1082.0 LB	3805.2 LB
	+/- 68 PSF	54.9"	2156.6 LB	621.7 LB	2244.4 LB	71.4"	2806.5 LB	809.1 LB	2920.8 LB	77.9"	3060.4 LB	882.3 LB	3185.1 LB	92.9"	3651.4 LB	1052.7 LB	3800.1 LB	101.2"	3978.3 LB	1147.0 LB	4140.4 LB	107.1"	4211.3 LB	1214.1 LB	4382.8 LB
108"	+/- 38 PSF	68.8"	1734.7 LB	483.6 LB	1800.9 LB	89.5"	2256.5 LB	629.1 LB	2342.6 LB	96.4"	2431.9 LB	678.0 LB	2524.7 LB	109.6"	2762.9 LB	770.3 LB	2868.3 LB	117.3"	2959.3 LB	825.1 LB	3072.2 LB	120.0"	3026.4 LB	843.8 LB	3141.8 LB
	+/- 42 PSF	64.5"	1859.3 LB	508.9 LB	1927.7 LB	83.8"	2417.9 LB	661.8 LB	2506.8 LB	91.4"	2634.7 LB	721.2 LB	2731.7 LB	104.8"	3021.3 LB	827.0 LB	3132.4 LB	112.2"	3236.1 LB	885.8 LB	3355.1 LB	118.8"	3425.6 LB	937.6 LB	3551.6 LB
	+/- 46 PSF	61.4"	1958.6 LB	529.5 LB	2028.9 LB	79.8"	2546.6 LB	688.4 LB	2638.0 LB	87.0"	2774.5 LB	750.1 LB	2874.1 LB	101.3"	3231.8 LB	873.7 LB	3347.8 LB	108.5"	3461.5 LB	935.8 LB	3585.7 LB	114.9"	3664.2 LB	990.6 LB	3795.7 LB
	+/- 50 PSF	58.6"	2055.3 LB	549.8 LB	2127.6 LB	76.2"	2672.0 LB	714.8 LB	2766.0 LB	83.1"	2910.7 LB	778.7 LB	3013.1 LB	98.2"	3440.5 LB	920.4 LB	3561.5 LB	105.2"	3685.1 LB	985.8 LB	3814.6 LB	111.3"	3900.9 LB	1043.6 LB	4038.0 LB
	+/- 56 PSF	54.9"	2201.1 LB	581.0 LB	2276.5 LB	71.4"	2861.0 LB	755.2 LB	2959.0 LB	77.8"	3116.1 LB	822.5 LB	3222.8 LB	92.9"	3720.0 LB	982.0 LB	3847.5 LB	100.6"	4028.9 LB	1063.5 LB	4166.9 LB	106.5"	4264.9 LB	1125.8 LB	4410.9 LB
	+/- 68 PSF	49.7"	2442.7 LB	633.8 LB	2523.6 LB	64.6"	3174.2 LB	823.7 LB	3279.3 LB	70.3"	3456.4 LB	896.9 LB	3570.9 LB	84.0"	4126.8 LB	1070.9 LB	4263.5 LB	94.0"	4616.3 LB	1197.9 LB	4769.2 LB	99.5"	4886.6 LB	1268.0 LB	5048.5 LB
120"	+/- 38 PSF	62.7"	1951.3 LB	490.0 LB	2011.9 LB	81.5"	2534.6 LB	636.4 LB	2613.3 LB	88.7"	2758.7 LB	692.7 LB	2844.3 LB	102.1"	3178.2 LB	798.0 LB	3276.9 LB	109.4"	3404.1 LB	854.7 LB	3509.8 LB	115.8"	3603.5 LB	904.8 LB	3715.3 LB
	+/- 42 PSF	58.9"	2082.5 LB	516.8 LB	2145.7 LB	76.5"	2704.6 LB	671.2 LB	2786.6 LB	83.3"	2943.3 LB	730.4 LB	3032.6 LB	97.9"	3460.0 LB	858.6 LB	3565.0 LB	104.9"	3706.0 LB	919.7 LB	3818.4 LB	111.0"	3923.0 LB	973.5 LB	4042.0 LB
	+/- 46 PSF	56.2"	2187.4 LB	538.6 LB	2252.7 LB	73.0"	2840.5 LB	699.4 LB	2925.4 LB	79.4"	3090.9 LB	761.0 LB	3183.2 LB	94.8"	3689.9 LB	908.5 LB	3800.1 LB	101.5"	3952.2 LB	973.1 LB	4070.2 LB	107.5"	4183.7 LB	1030.1 LB	4308.6 LB
	+/- 50 PSF	53.8"	2289.9 LB	560.0 LB	2357.4 LB	69.8"	2973.3 LB	727.2 LB	3061.0 LB	76.0"	3235.2 LB	791.2 LB	3330.5 LB	90.7"	3864.2 LB	945.1 LB	3978.0 LB	98.5"	4196.7 LB	1026.4 LB	4320.4 LB	104.3"	4442.5 LB	1086.5 LB	4573.4 LB
	+/- 56 PSF	50.5"	2444.6 LB	592.9 LB	2515.4 LB	65.5"	3173.8 LB	769.8 LB	3265.8 LB	71.3"	3452.9 LB	837.5 LB	3553.0 LB	85.1"	4124.5 LB	1000.3 LB	4244.1 LB	94.4"	4573.1 LB	1109.1 LB	4705.7 LB	99.9"	4840.9 LB	1174.1 LB	4981.2 LB
	+/- 68 PSF	45.8"	2701.5 LB	648.4 LB	2778.2 LB	59.4"	3506.9 LB	841.7 LB	3606.5 LB	64.6"	3814.8 LB	915.6 LB	3923.1 LB	77.2"	4557.0 LB	1093.7 LB	4686.5 LB	88.4"	5216.7 LB	1252.0 LB	5364.8 LB	93.6"	5522.2 LB	1325.4 LB	5679.0 LB
132"	+/- 38 PSF	58.0"	2148.7 LB	498.3 LB	2205.7 LB	75.2"	2788.0 LB	646.5 LB	2862.0 LB	81.8"	3031.5 LB	703.0 LB	3112.0 LB	96.4"	3571.1 LB	828.1 LB	3665.8 LB	103.2"	3824.9 LB	887.0 LB	3926.4 LB	109.3"	4048.9 LB	938.9 LB	4156.4 LB
	+/- 42 PSF	54.6"	2287.5 LB	526.3 LB	2347.3 LB	70.8"	2967.9 LB	682.9 LB	3045.5 LB	77.0"	3226.8 LB	742.5 LB	3311.1 LB	92.0"	3855.7 LB	887.2 LB	3956.4 LB	99.0"	4153.2 LB	955.6 LB	4261.8 LB	104.9"	4396.5 LB	1011.6 LB	4511.3 LB
	+/-																								

STORM BAR AND INTERMEDIATE END RETENTION MULLION CONNECTION DETAILS

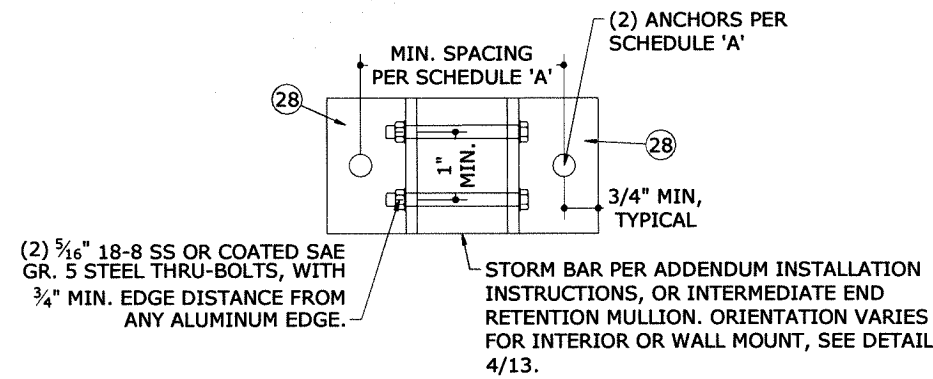

1 INTERIOR OR WALL MOUNT
13 N.T.S.

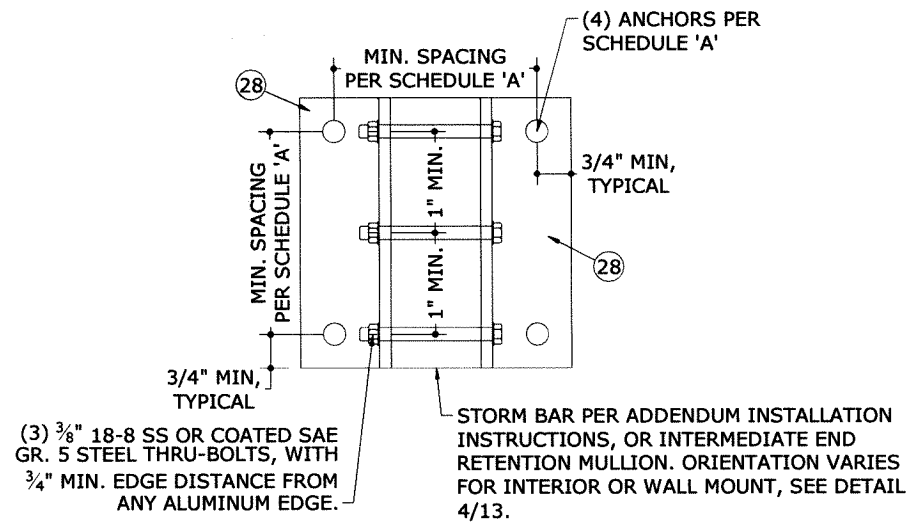

2 INTERIOR OR WALL MOUNT
13 N.T.S.

ANCHOR NOTES:

- ANCHORS SHALL BE INSTALLED IN ACCORDANCE WITH MANUFACTURERS' RECOMMENDATIONS.
- MINIMUM EMBEDMENT SHALL BE AS NOTED IN ANCHOR SCHEDULE. MINIMUM EMBEDMENT AND EDGE DISTANCE EXCLUDES STUCCO, FOAM, BRICK, AND OTHER WALL FINISHES.
- ANCHOR SCHEDULE APPLIES TO ALL PRODUCTS CERTIFIED HEREIN.
- WHERE EXISTING STRUCTURE IS WOOD FRAMING, EXISTING CONDITIONS MAY VARY. FIELD VERIFY THAT FASTENERS ARE INTO ADEQUATE WOOD FRAMING MEMBERS, NOT INTO PLYWOOD.
- MACHINE SCREWS SHALL HAVE MINIMUM OF 5/8" ENGAGEMENT OF THREADS IN BASE ANCHOR AND MAY HAVE EITHER A PAN HEAD, TRUSS HEAD, OR WAFER HEAD ("SIDEWALK BOLT") U.N.O.
- * ANCHOR SHALL PENETRATE THROUGH FACE SHELL INTO GROUTED CELL.

SCHEDULE 'A'

ANCHOR TYPE	MINIMUM SPACING	MINIMUM EDGE DISTANCE	CONNECTION DETAIL	MOUNTING CONDITION	CONNECTION CAPACITY
3/8" DEWALT SCREW BOLTS W/ 3-1/2" EMBED TO 3KSI MIN. CONCRETE	4.5"	4.5"	1/13	WALL MOUNT	4332 LB
			2/13	WALL MOUNT	8820 LB
3/8" DEWALT STEEL DROPIN W/ 1-9/16" EMBED TO 3KSI MIN. CONCRETE	4.5"	5.25"	1/13	WALL MOUNT	1590 LB
			2/13	WALL MOUNT	3180 LB
3/8" DEWALT SCREW BOLTS W/ 3-1/2" EMBED TO GROUT-FILLED CONCRETE BLOCK*	6.0"	12.0"	1/13	WALL MOUNT	2200 LB
			2/13	WALL MOUNT	5160 LB
5/16" ITW TAPCON XL OR DEWALT ULTRACON W/ 2-1/4" MIN. EMBED TO 3.5KSI MIN. CONCRETE	5.0"	3.125"	1/13	WALL MOUNT	2580 LB
			2/13	WALL MOUNT	4400 LB
5/16" ITW TAPCON XL OR DEWALT ULTRACON W/ 2-1/4" MIN. EMBED TO GROUT-FILLED CONCRETE BLOCK	5.0"	3.125"	1/13	WALL MOUNT	1576 LB
			2/13	WALL MOUNT	1702 LB
5/16" LAG SCREW W/ 2" MIN. THREAD PENETRATION TO G=0.42 MIN WOOD	2.0"	1.25"	1/13	WALL MOUNT	3152 LB
			2/13	WALL MOUNT	3404 LB
			1/13	WALL MOUNT	584 LB
			2/13	WALL MOUNT	744 LB
			1/13	INTERIOR MOUNT	1168 LB
			2/13	INTERIOR MOUNT	1488 LB
			1/13	INTERIOR MOUNT	1310 LB
			2/13	INTERIOR MOUNT	302 LB
			1/13	INTERIOR MOUNT	2620 LB
			2/13	INTERIOR MOUNT	604 LB

- CLUSTER OF (4) 3/8" POWERS WEDGE BOLTS AT CENTERED EACH STORM BAR W/ 3/2" MIN. EMBED, 3" MIN. EDGE DISTANCE, AND 4" SPACING TO 3KSI MIN. CONCRETE. BALANCE SPACED AT 18" O.C. MAX
- CLUSTER OF (4) 5/16" ITW TAPCONS AT CENTERED EACH STORM BAR W/ 2-1/4" MIN. EMBED, 4" MIN. EDGE DISTANCE, AND 4" SPACING TO GROUT-FILLED CONCRETE BLOCK. BALANCE SPACED AT 18" O.C. MAX
- CLUSTER OF (4) 5/16" LAG SCREWS AT CENTERED EACH STORM BAR W/ 2" MIN. THREAD PENETRATION, 1-1/4" MIN. EDGE DISTANCE, AND 2" SPACING TO G=0.42 MIN. WOOD. BALANCE SPACED AT 18" O.C. MAX

(2) 1/4" 18-8 SS OR COATED SAE GR. 5 STEEL THRU-BOLTS, WITH 1/2" MIN. EDGE DISTANCE FROM ANY ALUMINUM EDGE.

(15) ONE EACH SIDE OF STORM BAR, TYPICAL

OPTIONAL STORM BARS PER ADDENDUM INSTALLATION INSTRUCTIONS

(2) 1/4" 18-8 SS OR COATED SAE GR. 5 STEEL THRU-BOLTS, WITH 1/2" MIN. EDGE DISTANCE FROM ANY ALUMINUM EDGE.

(28) ONE EACH SIDE OF STORM BAR, TYPICAL

6063-T6 ALUMINUM BAR, 0.25" MIN. THICKNESS. SIZE VARIES PER STORM BAR SIZE.

(2) 1/4"-20 18-8 SS OR COATED SAE GR. 5 STEEL THRU-BOLTS PER ANGLE W/ 1/2" MIN EDGE DISTANCE TO ANY ALUMINUM EDGE

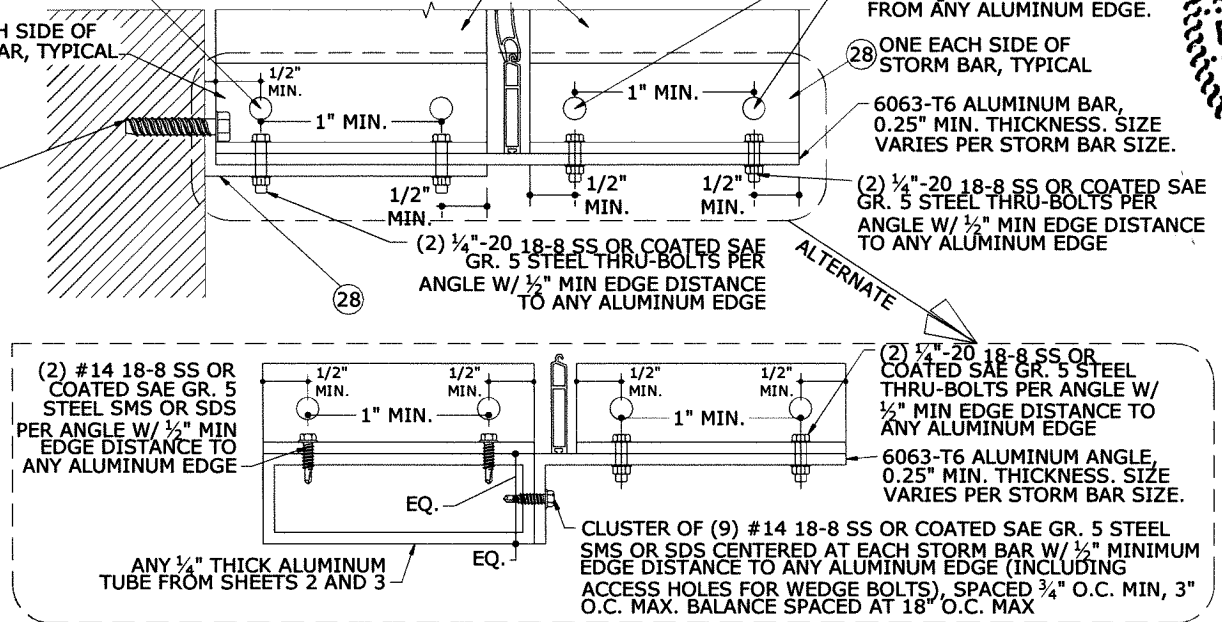

CONNECTION CAPACITY: 2276 LB

3 STORM BAR BUILD-OUT MOUNT
13 N.T.S.

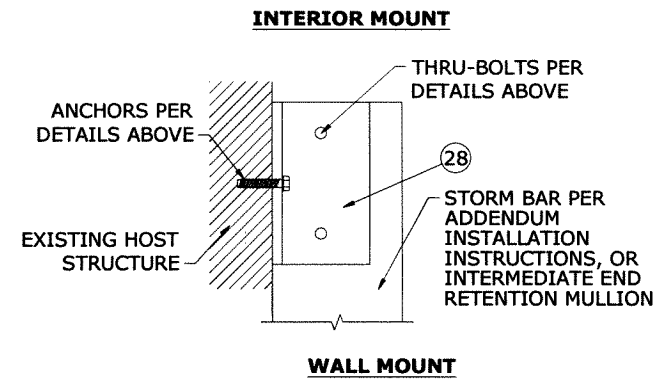
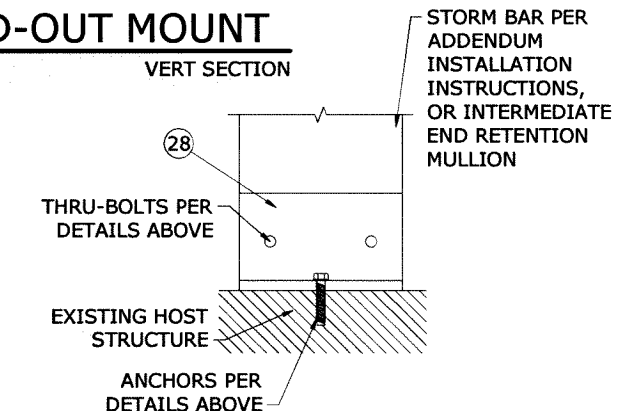

4 MOUNTING CONDITIONS
13 N.T.S.

FRANK BENNARDO, P.E.
PE# 06063
STATE OF TEXAS
11/10/2020
FRANK L. BENNARDO
ENGINEERING EXPERTS, INC.
CORPORATE OFFICE
160 SW 12TH AVE, SUITE 300
DEERFIELD BEACH, FL 33442
(954) 354-0660 | (888) 394-9989
TEAM@ENGINEERINGEXPERTS.COM
ENGINEERING EXPERTS, INC.

Town & Country
INDUSTRIES
Wholesale Aluminum and Building Products
A member of Alco supply Co., Inc.
400 WEST MCNAB ROAD
FT. LAUDERDALE, FL 33309

REMARKS	DRWN	CHKD	DATE
INIT ISSUE	KL	FLB	4/25/14
REV FOR TDI	RWN	TSB	6/04/14
2014 FBC	RWN	CSL	4/08/15
2017 FBC	RWN	FLB	8/07/17
2019 IBC	CCB	RWN	6/30/20

COPYRIGHT FRANK L. BENNARDO P.E.
20-24244.3a
SCALE: -
PAGE DESCRIPTION:

END RETENTION END MULLION CONNECTION DETAILS

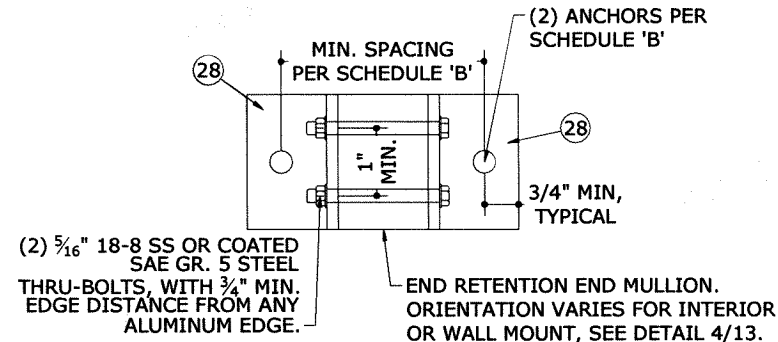

1 INTERIOR OR WALL MOUNT
14 N.T.S.

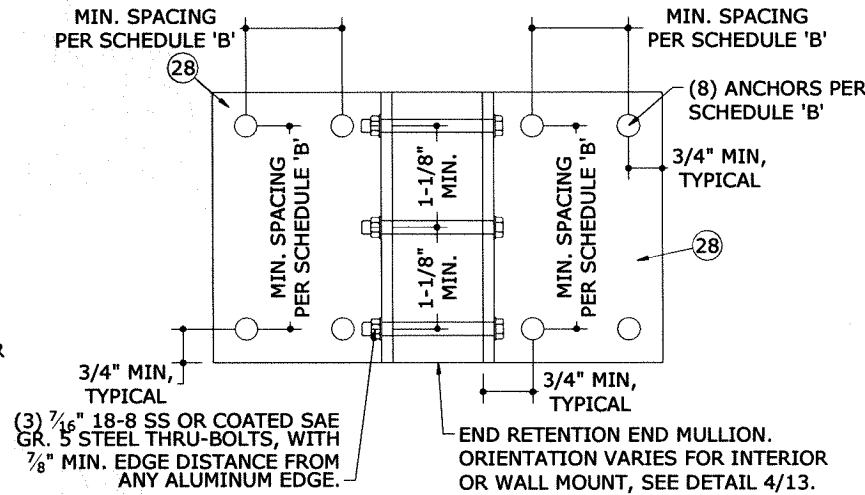

3 INTERIOR OR WALL MOUNT
14 N.T.S.

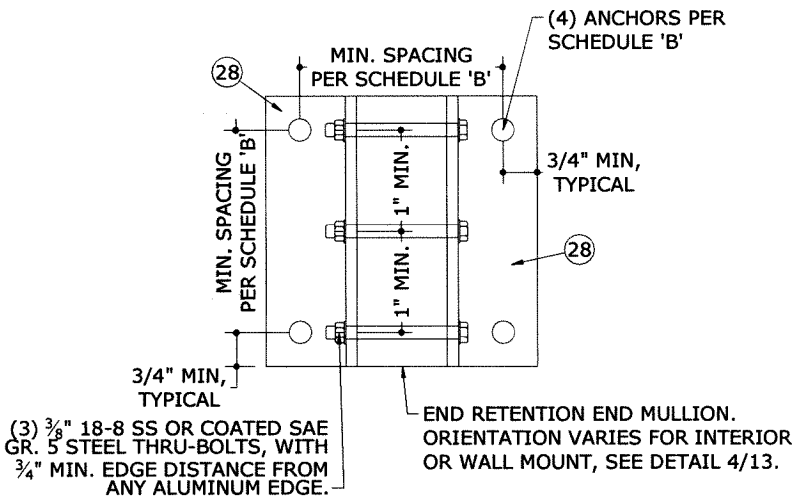

2 INTERIOR OR WALL MOUNT
14 N.T.S.

SCHEDULE 'B'

ANCHOR TYPE	MINIMUM SPACING	MINIMUM EDGE DISTANCE	CONNECTION DETAIL	CONNECTION CAPACITY	
				Tcap	Vcap
3/8" DEWALT SCREW BOLTS W/ 3-1/2" EMBED TO 3KSI MIN. CONCRETE	4.5"	4.5"	1/14	4332 LB	3065 LB
			2/14	8820 LB	6130 LB
	2.5"	4.5"	3/14	11819 LB	10176 LB
			2/14	1590 LB	1176 LB
3/8" DEWALT STEEL DROPIN W/ 1-9/16" EMBED TO 3KSI MIN. CONCRETE	4.5"	5.25"	1/14	2290 LB	3180 LB
			2/14	4580 LB	5313 LB
	2.5"	5.25"	3/14	3689 LB	5313 LB
			2/14	2580 LB	2200 LB
3/8" DEWALT SCREW BOLTS W/ 3-1/2" EMBED TO GROUT-FILLED CONCRETE BLOCK*	6.0"	12.0"	1/14	5160 LB	4400 LB
			2/14	1576 LB	1702 LB
	5.0"	3.125"	1/14	3152 LB	3404 LB
			2/14	584 LB	744 LB
5/16" ITW TAPCON XL OR DEWALT ULTRACON W/ 2-1/4" MIN. EMBED TO GROUT-FILLED CONCRETE BLOCK	5.0"	3.125"	1/14	1168 LB	1488 LB
			2/14	1310 LB	302 LB
	2.0"	1.25"	1/14	2620 LB	604 LB
			2/14		

SCHEDULE 'B' NOTES:

- FOR INTERIOR MOUNT CONDITIONS WITH END RETENTION END MULLIONS, 'Rsum' VALUES IN MULLION SCHEDULE SHALL NOT EXCEED MAX 'Vcap' VALUES NOTED IN SCHEDULE 'B'.
- FOR WALL MOUNT CONDITIONS WITH END RETENTION END MULLIONS, $R_v/V_{cap} + R_t/T_{cap}$ SHALL BE LESS THAN OR EQUAL TO 1.0, WHERE 'Rv' AND 'Rt' ARE PER MULLION SCHEDULES, AND 'Tcap' AND 'Vcap' ARE PER SCHEDULE 'B'.
- * ANCHOR SHALL PENETRATE THROUGH FACE SHELL INTO GROUTED CELL.

STORM BAR TO HEADER CONNECTION DETAILS

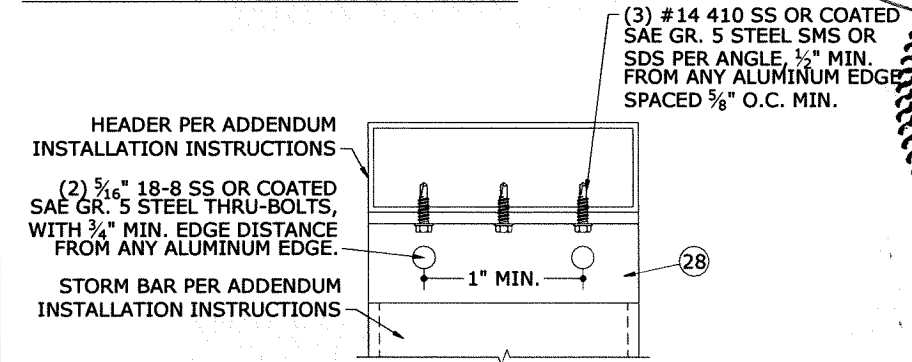

CONNECTION CAPACITY: 4262 LB

4 STORM BAR TO HEADER
14 N.T.S. VERT SECTION

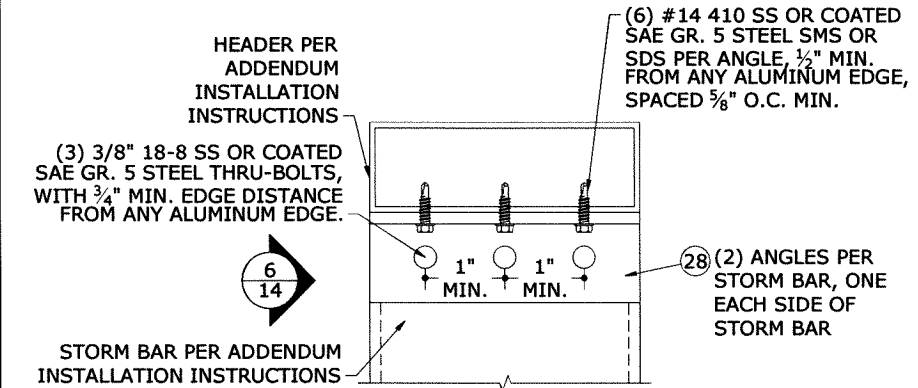

CONNECTION CAPACITY: 8524 LB

5 STORM BAR TO HEADER
14 N.T.S. VERT SECTION

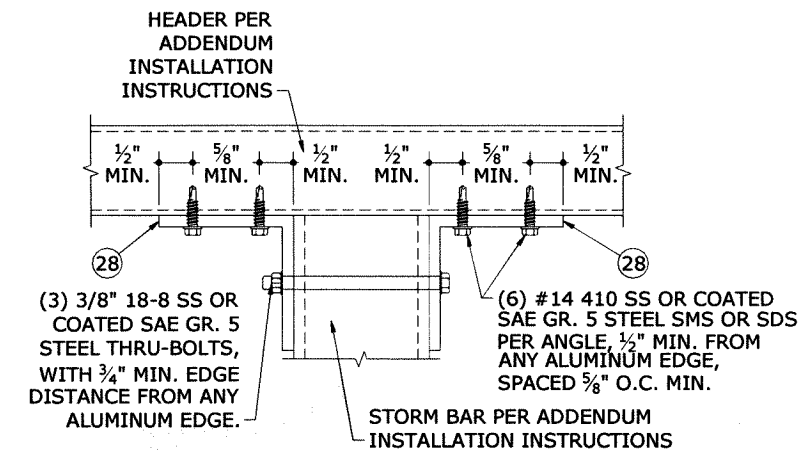

CONNECTION CAPACITY: 8524 LB

6 STORM BAR TO HEADER
14 N.T.S. VERT SECTION

FRANK BENNARDO, PE
PE# 96064 CA F-11383

STATE OF TEXAS
10/2020

FRANK L. BENNARDO
ENGINEER

ENGINEERING EXPERTS
CORPORATION
160 SW 12th AVE, SUITE 900
DEERFIELD BEACH, FL 33442
(954) 354-0660
TEAM@ENGINEERINGEXPERTS.COM

Wholesale Aluminum and Building Products
A Division of ABC Supply Co., Inc.

400 WEST MCNAB ROAD
FT. LAUDERDALE, FL 33309

DRWN CHKD DATE
KL FLB 4/25/14
RWN TSB 6/04/14
RWN CSL 4/08/15
RWN FLB 8/07/17
CCB RWN 6/30/20

REMARKS
INIT ISSUE
REV FOR TDI
2014 FBC
2017 FBC
2018 IBC

THIS DOCUMENT IS THE PROPERTY OF FRANK L. BENNARDO, P.E. AND SHALL NOT BE REPRODUCED IN WHOLE OR PART WITHOUT WRITTEN CONSENT OF FRANK L. BENNARDO, P.E. TO THIS DOCUMENT ARE NOT PERMITTED AND INVALIDATE OUR CERTIFICATION.

COPYRIGHT FRANK L. BENNARDO P.E.
20-24244.3a

SCALE: -
PAGE DESCRIPTION:

14

HEADER CONNECTION DETAILS

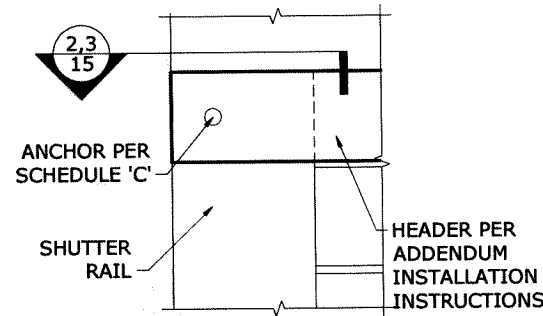

1 BUILD-OUT & WALL MOUNT
15 N.T.S. ELEV

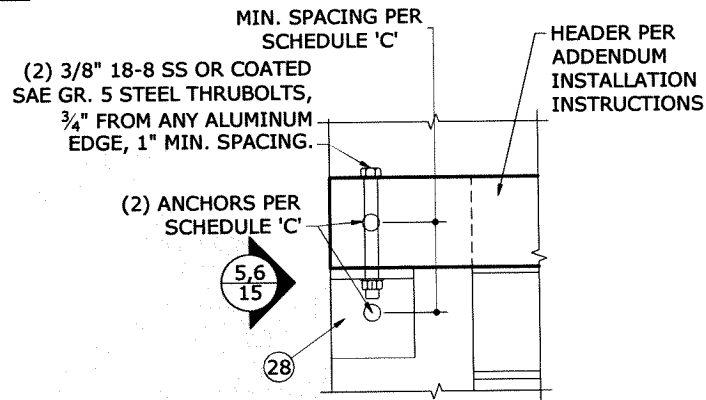

4 BUILD-OUT & WALL MOUNT
15 N.T.S. ELEV

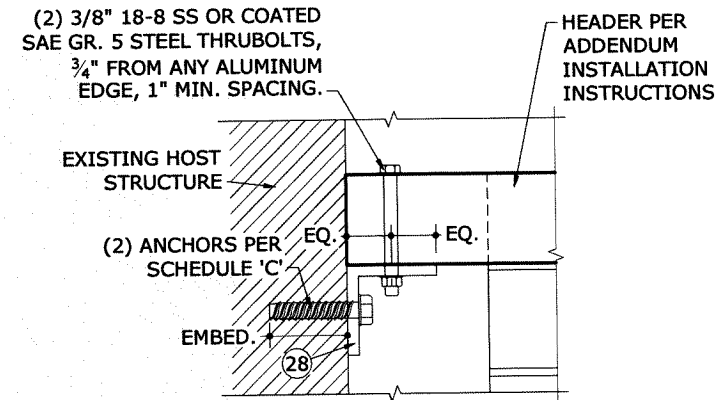

7 INTERIOR MOUNT
15 N.T.S. ELEV

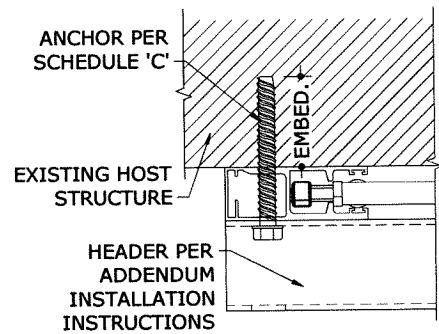

2 WALL MOUNT
15 N.T.S. HORIZ SECTION

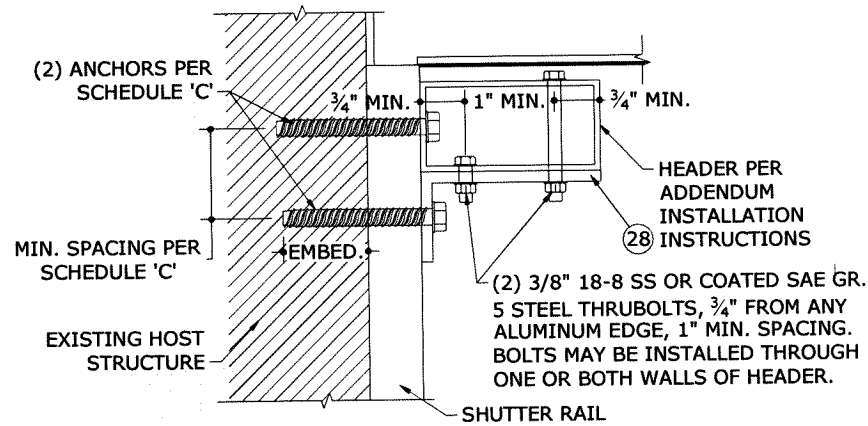

5 WALL MOUNT
15 N.T.S. VERT SECTION

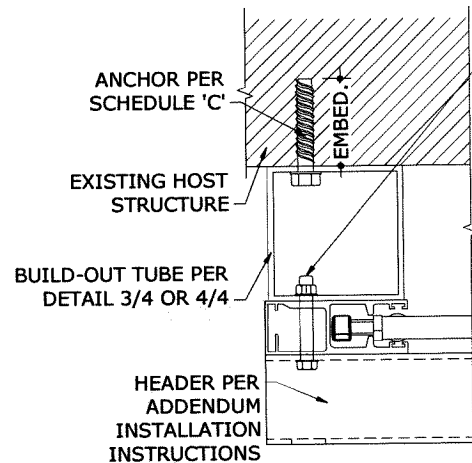

3 BUILD-OUT MOUNT
15 N.T.S. HORIZ SECTION

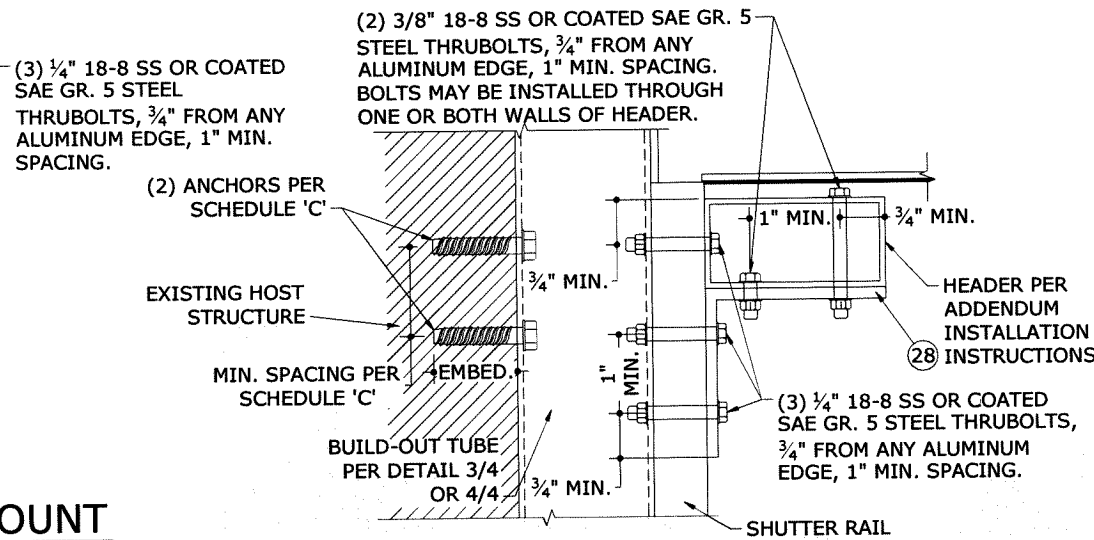

6 BUILD-OUT MOUNT
15 N.T.S. VERT SECTION

SCHEDULE 'C'

ANCHOR TYPE	MINIMUM SPACING	MINIMUM EDGE DISTANCE	MOUNTING CONDITION	NUMBER OF ANCHORS	CONNECTION CAPACITY
3/8" DEWALT SCREW BOLTS W/ 3-1/2" EMBED TO 3KSI MIN. CONCRETE	4.5"	4.5"	BUILD-OUT OR WALL MOUNT	1	2205 LB
			INTERIOR MOUNT	2	3093 LB
	2.5"	4.5"	BUILD-OUT OR WALL MOUNT	1	1533 LB
			INTERIOR MOUNT	2	3065 LB
3/8" DEWALT SCREW BOLTS W/ 3-1/2" EMBED TO GROUT-FILLED CONCRETE BLOCK*	6.0"	12.0"	BUILD-OUT OR WALL MOUNT	1	1477 LB
			INTERIOR MOUNT	2	2955 LB
	4.5"	5.25"	BUILD-OUT OR WALL MOUNT	1	1272 LB
			INTERIOR MOUNT	2	2544 LB
3/8" DEWALT STEEL DROPIN W/ 1-9/16" EMBED TO 3KSI MIN. CONCRETE	6.0"	12.0"	BUILD-OUT OR WALL MOUNT	1	1290 LB
			INTERIOR MOUNT	2	2580 LB
	4.5"	5.25"	BUILD-OUT OR WALL MOUNT	1	1100 LB
			INTERIOR MOUNT	2	2200 LB
5/16" ITW TAPCON XL OR DEWALT ULTRACON W/ 2-1/4" MIN. EMBED TO 3.5KSI MIN. CONCRETE	4.5"	5.25"	BUILD-OUT OR WALL MOUNT	1	795 LB
			INTERIOR MOUNT	2	1590 LB
	2.5"	5.25"	BUILD-OUT OR WALL MOUNT	1	1145 LB
			INTERIOR MOUNT	2	2290 LB
5/16" ITW TAPCON XL OR DEWALT ULTRACON W/ 2-1/4" MIN. EMBED TO GROUT-FILLED CONCRETE BLOCK	5.0"	4.0"	BUILD-OUT OR WALL MOUNT	1	461 LB
			INTERIOR MOUNT	2	922 LB
	5.0"	3.125"	BUILD-OUT OR WALL MOUNT	1	664 LB
			INTERIOR MOUNT	2	1328 LB
5/16" LAG SCREW W/ 2" MIN. THREAD PENETRATION TO G=0.42 MIN WOOD	5.0"	4.0"	BUILD-OUT OR WALL MOUNT	1	788 LB
			INTERIOR MOUNT	2	1576 LB
	5.0"	3.125"	BUILD-OUT OR WALL MOUNT	1	851 LB
			INTERIOR MOUNT	2	1702 LB
2.0"	1.25"	BUILD-OUT OR WALL MOUNT	1	292 LB	
		INTERIOR MOUNT	2	584 LB	
	2.0"	1.25"	BUILD-OUT OR WALL MOUNT	1	372 LB
			INTERIOR MOUNT	2	744 LB
2.0"	1.25"	BUILD-OUT OR WALL MOUNT	1	655 LB	
		INTERIOR MOUNT	2	1311 LB	
	2.0"	1.25"	BUILD-OUT OR WALL MOUNT	1	151 LB
			INTERIOR MOUNT	2	301 LB

- NOTES:**
- ALL ANCHORS SHALL BE 3/4" MINIMUM FROM ANY ALUMINUM EDGE.
 - * ANCHOR SHALL PENETRATE THROUGH FACE SHELL INTO GROUTED CELL

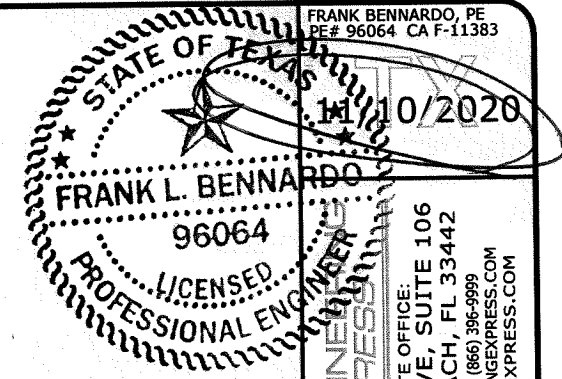

FRANK BENNARDO, PE
PE# 96064 CA F-11383
10/2020
FRANK L. BENNARDO
96064
LICENSED PROFESSIONAL ENGINEER
ENGINEERING EXPRESS, INC.
CORPORATE OFFICE:
160 SW 12th AVE, SUITE 106
DEERFIELD BEACH, FL 33442
(954) 354-0660 | (866) 396-9999
TEAM@ENGINEERINGEXPRESS.COM
ENGINEERINGEXPRESS.COM

Town & Country
INDUSTRIES
Wholesale Aluminum and Building Products
A Division of ABC Supply Co., Inc.
400 WEST MCNAB ROAD
FT. LAUDERDALE, FL 33309

DRWN	CHKD	DATE
KL	FLB	4/25/14
RWN	TSB	6/04/14
RWN	CSL	4/08/15
RWN	FLB	8/07/17
CCB	RWN	6/30/20

REMARKS
INIT ISSUE
REV FOR TDI
2014 FBC
2017 FBC
2018 IBC

THIS DOCUMENT IS THE PROPERTY OF FRANK L. BENNARDO, P.E. AND SHALL NOT BE REPRODUCED IN WHOLE OR PART WITHOUT WRITTEN CONSENT OF FRANK L. BENNARDO, P.E. ANY UNAUTHORIZED REPRODUCTION OR TRANSMISSION TO THIS DOCUMENT ARE NOT PERMITTED AND INVALIDATE OUR CERTIFICATION.

COPYRIGHT FRANK L. BENNARDO P.E.
20-24244.3a

SCALE: -
PAGE DESCRIPTION: -