

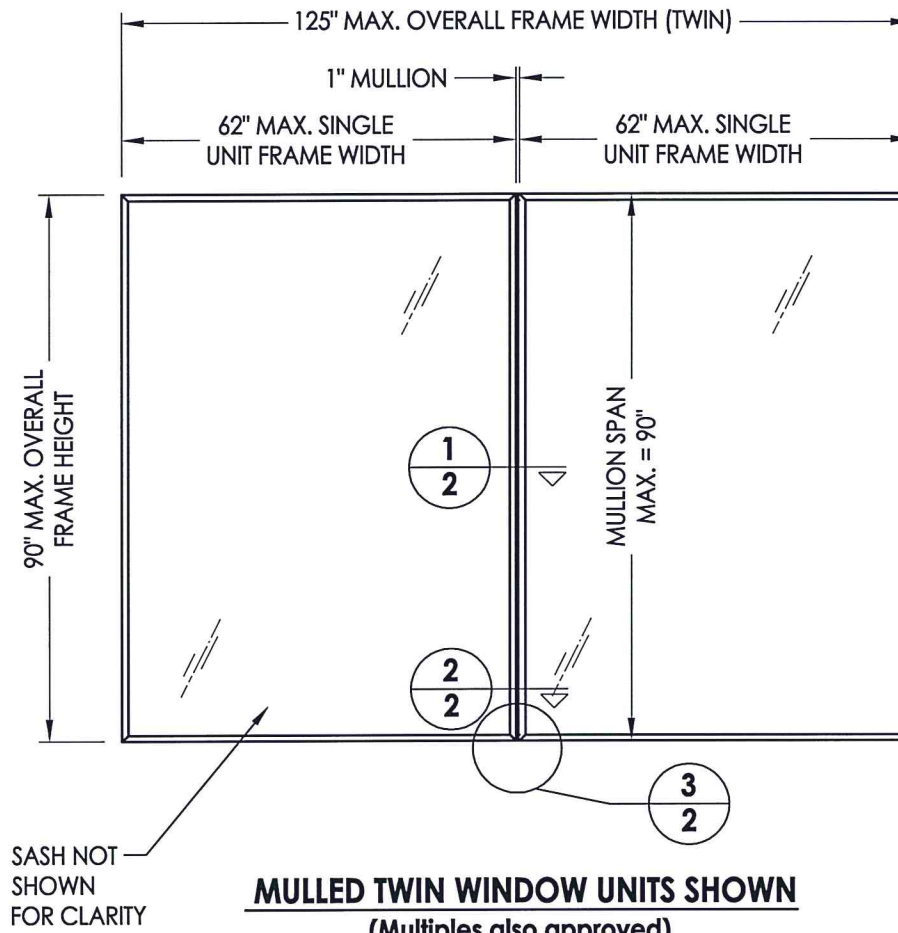

Bringing quality to light.

10250 Phillip Parkway
Streetsboro, Ohio 44241

19044 ALUMINUM MULLION

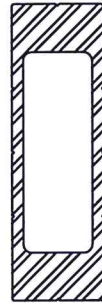

MULLED TWIN WINDOW UNITS SHOWN
(Multiples also approved)

EVALUATED FOR USE IN THE STATE OF TEXAS

The Soft-Lite Structural Mullion described herein complies with the 2006 International Residential Code (IRC), Sections R613.9 and the 2006 International Building Code (IBC), (including Texas Revisions), subject to the following conditions:

1. Anchors shall be as listed and spaced as shown in the details. Anchor embedment to base material shall be beyond wall covering.
2. When used in areas requiring wind-borne debris protection (Seaward and Inland I areas), this product complies with Section R301.2.1.2 of the IRC and Section 1609.1.2 of the IBC and does not require impact protection. This product meets missile level "D" and includes Wind Zone 3 as defined in ASTM E 1996.
3. Separate product approvals for each glazing product used with these mullions must be submitted along with this mullion product approval. The design pressure rating of the assembly shall be the lesser of the load capacity of the mullion as specified using this approval or the design pressure rating of the individual glazing products used.
4. Anchoring of each glazing product to the mullion shall be as shown in this drawing or as shown in each individual glazing product approval, whichever is more stringent.
5. Any conditions not covered in this evaluation are subject to separate engineering evaluation.
6. Mullied assemblies may be either factory assembled or site assembled.

TABLE OF CONTENTS	
SHEET #	DESCRIPTION
1	Typical elevations, design pressures & general notes
2	Mullion details & cross sections

MAX. MULLION SPAN	DESIGN PRESSURE (PSF)													
	MAX. SINGLE UNIT FRAME WIDTH													
	36"	38"	40"	42"	44"	46"	48"	50"	52"	54"	56"	58"	60"	62"
90"	50	48	46	44	42	40	39	38	37	36	35	35	34	34
88"	52	50	48	46	44	42	41	40	39	38	37	36	36	35
86"	55	53	50	48	46	45	43	42	41	40	39	38	37	37
84"	58	55	53	51	49	47	45	44	43	42	41	40	39	39
82"	62	59	56	54	52	51	49	48	46	45	44	43	42	42
80"	65	62	59	57	55	54	52	51	49	48	47	46	46	45
78"	69	66	63	61	59	57	55	54	52	51	50	50	49	48
76"	73	70	67	65	63	61	59	58	56	55	54	53	52	52
74"	75	75	71	69	67	65	63	62	60	59	58	57	56	56
72"	75	75	75	74	72	70	68	66	65	63	62	62	61	60
70"	75	75	75	75	75	75	73	71	70	69	67	66	65	65
68"	75	75	75	75	75	75	75	75	74	74	73	72	71	70
66"	75	75	75	75	75	75	75	75	75	75	75	75	75	75

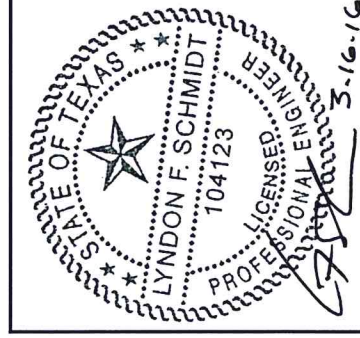

Documents Prepared By: Lyndon F. Schmidt, P.E.
TEXAS P.E. #104123

RW BUILDING CONSULTANTS, INC.
P.O. Box 230 Veroico FL 33595
Phone No.: 813.659.9197

TEXAS BOARD OF PROFESSIONAL ENGINEERS
CERTIFICATE OF REGISTRATION # F-11852

PRODUCT: 19044 ALUMINUM MULLION

PART OR ASSEMBLY: TYPICAL ELEVATIONS, DESIGN PRESSURES & GENERAL NOTES

NO.	DATE	BY	REVISIONS

DATE: 12/02/15

SCALE: N.T.S.

DWG. BY: JK

CHK. BY: LFS

DRAWING NO.: TX-4590

SHEET 1 OF 2

X:\Clients\Soft-Lite Permanent\B - Texas Dept of Ins\TDI - MU XXX - Clipped Mullions Job 96\Drawings\TX-4590.dwg, 2

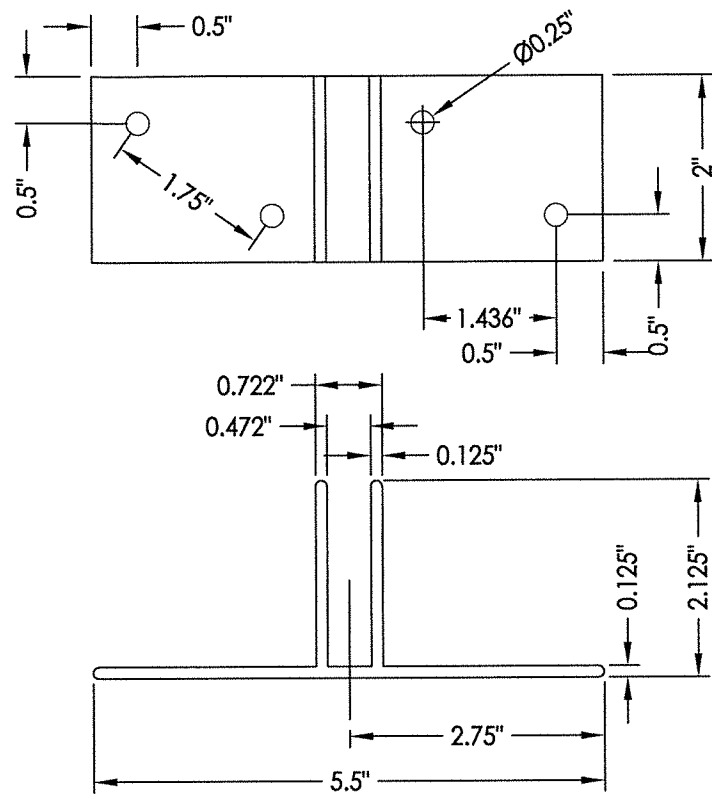

2 18102 ANCHOR BRACKET
6063-T5 ALUM.

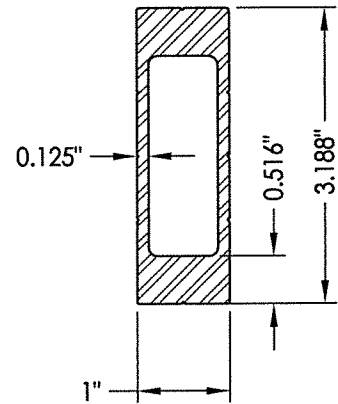

1 19044 MULLION
6063-T5 ALUM.

Shown with Soft-Lite fixed casement frame under separate approval.

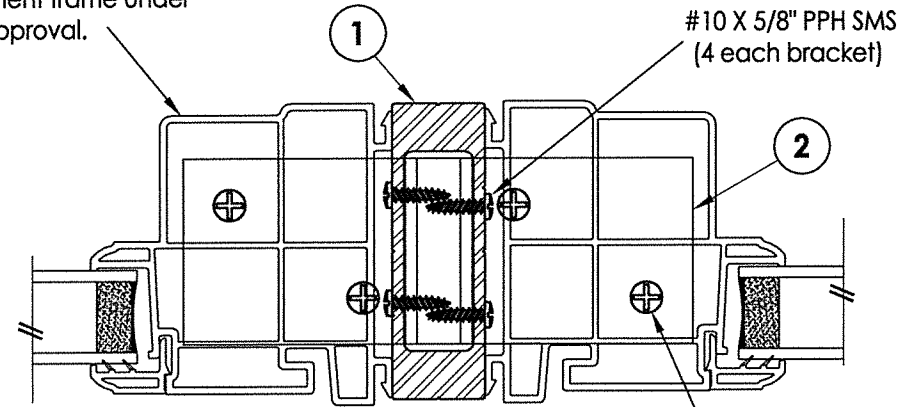

1 HORIZONTAL CROSS SECTION
2 @ anchor clip

(4) Mullion Bracket anchors required into substrate (See ANCHOR SCHEDULE)

Refer to separate window approval for quantity, location & size of anchors required to fasten window frame to mullion. At a minimum, use #10-16 PPH Self-drilling SMS located 6" from each end and spaced 18" max. o.c. (a min. of 3 threads must protrude through the mullion face).

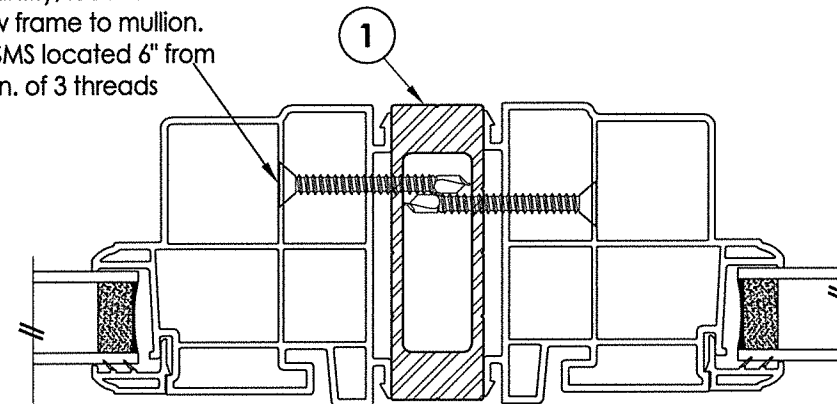

2 HORIZONTAL CROSS SECTION
2 through mullion

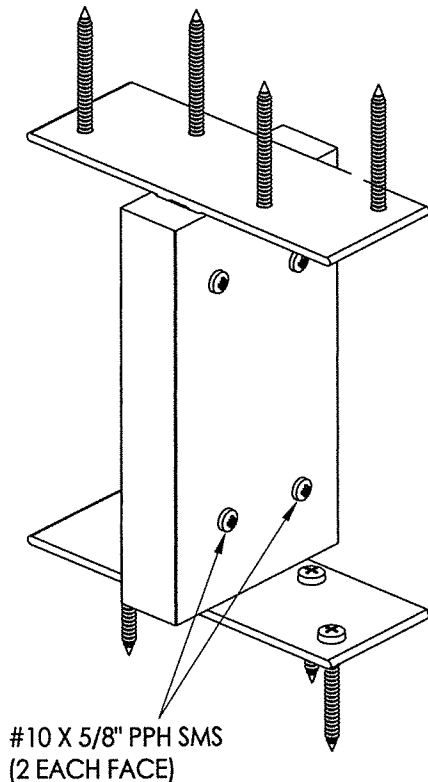

#10 X 5/8" PPH SMS
(2 EACH FACE)

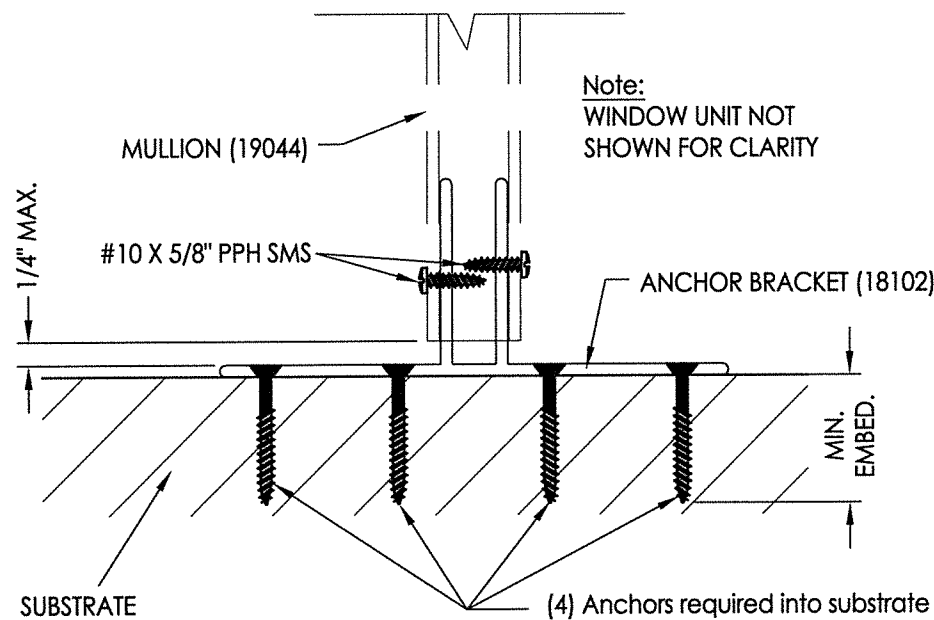

BRACKET-TO-MULLION DETAIL



3 ANCHOR BRACKET DETAIL
2

Note:
WINDOW UNIT NOT SHOWN FOR CLARITY

(4) Anchors required into substrate (See ANCHOR SCHEDULE)

MULLION ANCHOR BRACKET ANCHOR SCHEDULE				
SUBSTRATE	ANCHOR	EMBEDMENT	EDGE DISTANCE	CENTER-TO-CENTER SPACING
WOOD	#12 PFH WOOD SCREW 	1-1/2" MIN.	1" MIN.	1-1/2" MIN.
CONCRETE	1/4" DIA. PFH ELCO ULTRACON® 	1-3/4" MIN.	2-1/2" MIN.	1-1/2" MIN.
STEEL	12-14 HWH HILTI KWIK-FLEX® SELF-DRILLING SCREW 	A MIN. OF 3 THREADS SHALL PROTRUDE THROUGH THE STEEL SUBSTRATE	1" MIN.	1-1/2" MIN.

WOOD FRAMING (S.G. >= 0.55)
CONCRETE CONFORMING TO ACI 301 (3,000 PSI MIN.) OR HOLLOW BLOCK CONFORMING TO ASTM C90
STEEL CONFORMING TO ASTM A653, 16 GA., 0.060" MIN. THICKNESS (Fy = 33,000 PSI, Fu = 45,000 PSI)

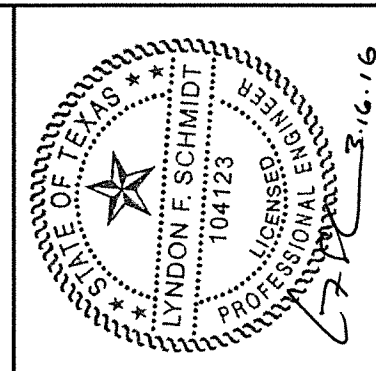

Documents Prepared By: Lyndon F. Schmidt, P.E.
TEXAS P.E. #104123

RW BUILDING CONSULTANTS, INC.
P.O. Box 230 Valrico FL 33595
Phone No.: 813.659.9197

TEXAS BOARD OF PROFESSIONAL ENGINEERS
CERTIFICATE OF REGISTRATION # F-11852

PRODUCT: 19044 ALUMINUM MULLION
PART OR ASSEMBLY: MULLION DETAILS & CROSS SECTIONS

NO.	DATE	BY

DATE: 12/02/15
SCALE: N.T.S.
DWG. BY: JK
CHK. BY: LFS
DRAWING NO.: TX-4590
SHEET 2 OF 2

© 2015 R.W. BUILDING CONSULTANTS INC.