

**"I" SERIES STRUCTURAL
TRANSOM MULLION**

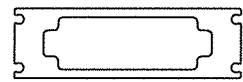

MULLION

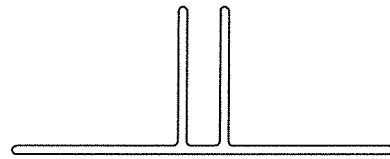

GOAL POST STYLE BRACKET

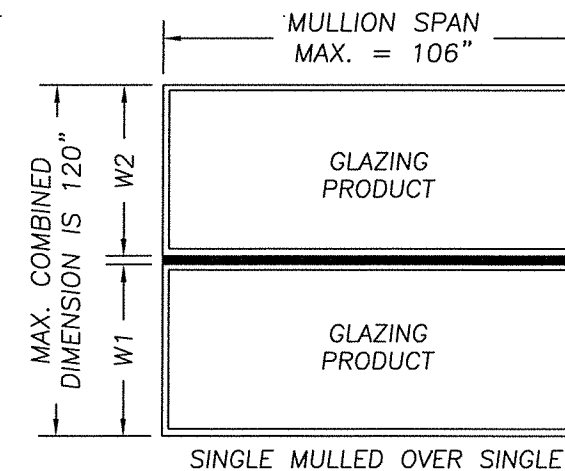
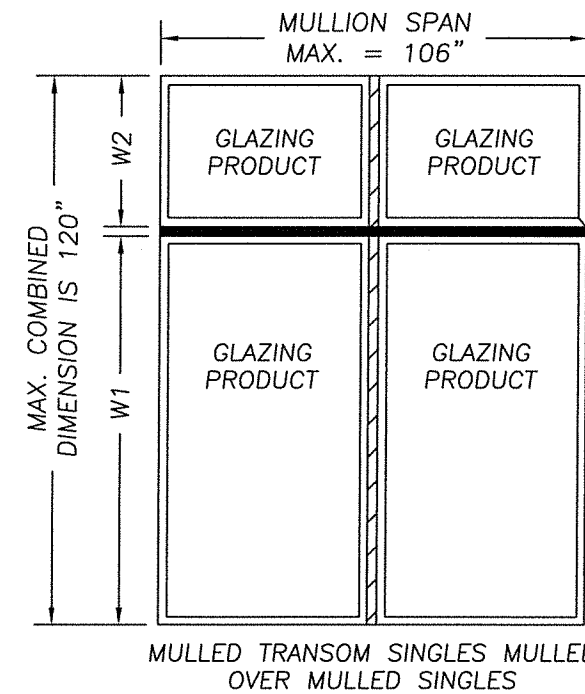
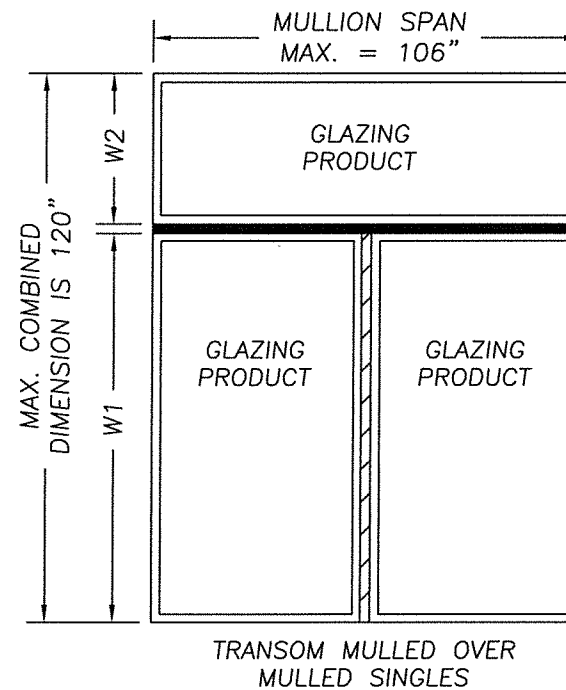
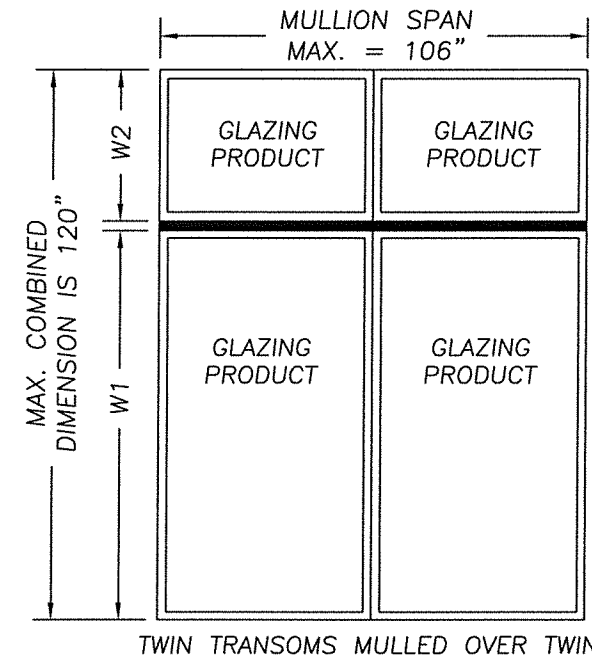
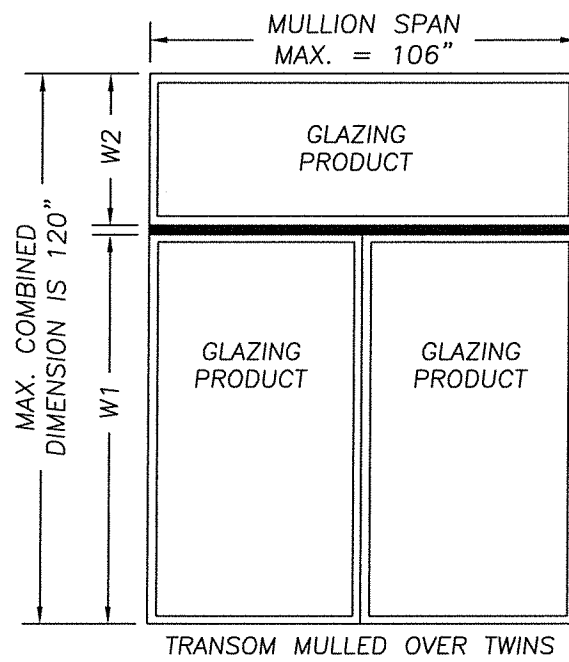

**TYPICAL MULLION
CONFIGURATIONS**

NOTICE:
VERTICAL MULLIONS DEPICTED HERE ARE
COVERED UNDER SEPARATE APPROVAL

GENERAL NOTES:

THE ALUMINUM STRUCTURAL MULLIONS DESCRIBED HEREIN COMPLY WITH THE 2018 INTERNATIONAL RESIDENTIAL CODE (IRC) AND THE 2018 INTERNATIONAL BUILDING CODE (IBC) SUBJECT TO THE FOLLOWING CONDITIONS:

1. MULLION ANCHOR EMBEDMENT TO BASE MATERIAL SHALL BE BEYOND WALL DRESSING OR STUCCO.
2. SEPARATE PRODUCT APPROVALS FOR EACH ALSIDE GLAZING PRODUCT USED WITH THESE MULLIONS MUST BE SUBMITTED ALONG WITH THIS MULLION PRODUCT APPROVAL.
3. ANY CONDITIONS NOT COVERED IN THIS EVALUATION ARE SUBJECT TO SEPARATE ENGINEERING EVALUATION.
4. APPROVED ASSOCIATED MATERIALS TWIN UNITS OR APPROVED SINGLES CAN BE USED IN MULLION CONFIGURATIONS. THE VERTICAL AND HORIZONTAL MULLION CONFIGURATIONS CAN BE COMBINED TO MULL MULTIPLE SINGLE UNITS TOGETHER.
5. THE DESIGN PRESSURE RATING OF THE ASSEMBLY SHALL BE THE LESSER OF THE LOAD CAPACITY OF THE MULLION AS DETERMINED USING THIS APPROVAL OR THE DESIGN PRESSURE RATING OF THE INDIVIDUAL GLAZING PRODUCTS USED.
6. BOUNDING BOX DIMENSIONS FOR GEOMETRIC TRANSOM SHAPES MUST BE EQUAL TO OR LESS THAN THE RECTANGULAR TRANSOM DIMENSIONS SHOWN HEREIN.
7. THIS PRODUCT HAS BEEN ENGINEERED FOLLOWING ACCEPTED ENGINEERING PRACTICE CONFORMING TO THE REQUIREMENTS IN IRC SECTION R609.8.

TABLE OF CONTENTS	
SHEET #	DESCRIPTION
1	TYPICAL ELEVATIONS & GENERAL NOTES
2	MULLION LOAD TABLE FOR WOOD SCREW ANCHORS
3	MULLION LOAD TABLE FOR CONCRETE SCREW ANCHORS
4	MULLION SECTION & ANCHOR DETAILS

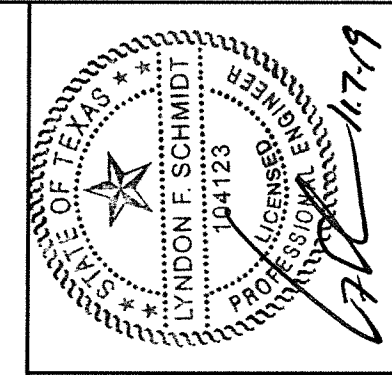

Documents Prepared By: Lyndon F. Schmidt, P.E.
TEXAS P.E. #104123

RW BUILDING CONSULTANTS, INC.
P.O. Box 230 Valrico FL 33595
Phone No.: 813.659.9197
TEXAS BOARD OF PROFESSIONAL ENGINEERS
CERTIFICATE OF REGISTRATION # F-11852

PRODUCT:	STRUCTURAL TRANSOM
PART OR ASSEMBLY:	TYPICAL ELEVATION AND GENERAL NOTES

NO.	DATE	BY	REVISIONS
1	11/06/19	LFS	UPDATE TO 2018 IBC/IRC

DATE:	8/08/13
SCALE:	NTS
DWG. BY:	JK
CHK. BY:	LFS
DRAWING NO.:	TX-4359
SHEET	1 of 4

R:\Clients\Associated PERMANENT B - Texas Dept of Ins\Mullions\TDI -Series I\Structural Mullion\TDI 2018 IBC RENEWAL\TX-4359.dwg, 2

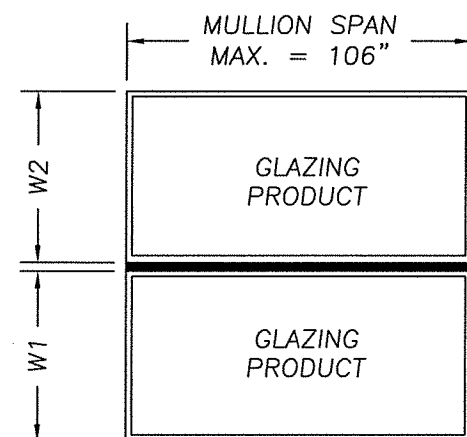
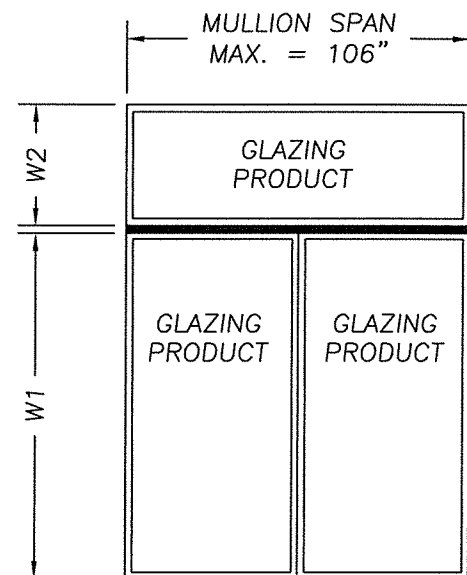

$$\text{TRIBUTARY WIDTH} = \frac{W1 + W2}{2}$$

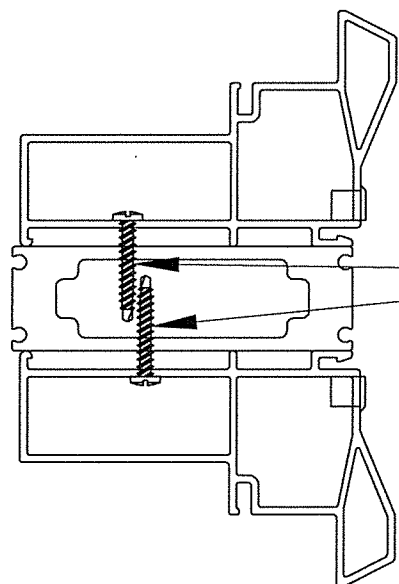

SECTION THRU MULLION & FRAME

WOOD SCREW ANCHORS	"I" SERIES STRUCTURAL TRANSOM MULLION LOAD TABLE (PSF)													
	TRIBUTARY WIDTH													
	24"	28"	32"	36"	40"	42"	44"	48"	50"	52"	54"	56"	60"	
MULLION SPAN	106"	40.0	34.0	30.0	27.0	24.0	23.0	22.0	20.0	19.0	18.0	18.0	17.0	16.0
100"	48.0	41.0	36.0	32.0	29.0	27.0	26.0	24.0	23.0	22.0	21.0	20.0	19.0	
96"	54.0	47.0	41.0	36.0	32.0	31.0	29.0	27.0	26.0	25.0	24.0	23.0	21.0	
92"	62.0	53.0	46.0	41.0	37.0	35.0	34.0	31.0	29.0	28.0	27.0	26.0	24.0	
88"	71.0	61.0	53.0	47.0	42.0	40.0	38.0	35.0	34.0	32.0	31.0	30.0	28.0	
86"	75.0	65.0	57.0	50.0	45.0	43.0	41.0	38.0	36.0	35.0	33.0	32.0	30.0	
84"	75.0	70.0	61.0	54.0	49.0	46.0	44.0	41.0	39.0	37.0	36.0	35.0	32.0	
82"	75.0	75.0	66.0	58.0	52.0	50.0	48.0	44.0	42.0	40.0	39.0	37.0	35.0	
80"	75.0	75.0	71.0	63.0	56.0	54.0	51.0	47.0	45.0	43.0	42.0	40.0	37.0	
78"	75.0	75.0	75.0	68.0	61.0	58.0	55.0	51.0	49.0	47.0	45.0	43.0	40.0	
76"	75.0	75.0	75.0	73.0	66.0	63.0	60.0	55.0	53.0	51.0	49.0	47.0	44.0	
74"	75.0	75.0	75.0	75.0	72.0	68.0	65.0	60.0	57.0	55.0	53.0	51.0	48.0	
72"	75.0	75.0	75.0	75.0	74.0	70.0	67.0	62.0	59.0	57.0	55.0	53.0	49.0	
70"	75.0	75.0	75.0	75.0	75.0	72.0	69.0	63.0	61.0	58.0	56.0	54.0	51.0	
68"	75.0	75.0	75.0	75.0	75.0	75.0	71.0	65.0	63.0	60.0	58.0	56.0	52.0	
66"	75.0	75.0	75.0	75.0	75.0	75.0	73.0	67.0	64.0	62.0	60.0	57.0	54.0	
64"	75.0	75.0	75.0	75.0	75.0	75.0	75.0	69.0	66.0	64.0	62.0	59.0	55.0	
62"	75.0	75.0	75.0	75.0	75.0	75.0	75.0	72.0	69.0	66.0	64.0	61.0	57.0	
60"	75.0	75.0	75.0	75.0	75.0	75.0	75.0	74.0	71.0	68.0	66.0	63.0	59.0	
58"	75.0	75.0	75.0	75.0	75.0	75.0	75.0	75.0	73.0	71.0	68.0	65.0	61.0	
56"	75.0	75.0	75.0	75.0	75.0	75.0	75.0	75.0	75.0	73.0	70.0	68.0	63.0	
54"	75.0	75.0	75.0	75.0	75.0	75.0	75.0	75.0	75.0	75.0	73.0	70.0	66.0	
52"	75.0	75.0	75.0	75.0	75.0	75.0	75.0	75.0	75.0	75.0	75.0	73.0	68.0	
50"	75.0	75.0	75.0	75.0	75.0	75.0	75.0	75.0	75.0	75.0	75.0	75.0	71.0	
48"	75.0	75.0	75.0	75.0	75.0	75.0	75.0	75.0	75.0	75.0	75.0	75.0	74.0	
40"	75.0	75.0	75.0	75.0	75.0	75.0	75.0	75.0	75.0	75.0	75.0	75.0	75.0	

INSTRUCTIONS FOR USE OF THE MULLION LOAD TABLE:

1. DETERMINE THE DESIGN LOAD REQUIREMENT FOR THE PARTICULAR OPENING AS SPECIFIED BY THE BUILDING DESIGNER (ARCHITECT OR ENGINEER OR RECORD).
2. FOR THE PARTICULAR OPENING, DETERMINE THE TRIBUTARY WIDTH AND MULLION SPAN. REFERENCE THE SKETCHES ON THIS SHEET FOR MULLION SPAN AND TRIBUTARY WIDTH DETERMINATION.
3. IN THE FIRST COLUMN OF THE TABLE, LOCATE THE MULLION SPAN. IN THE FIRST ROW OF THE TABLE, LOCATE THE TRIBUTARY WIDTH. AT THE INTERSECTION OF THE ROW CONTAINING THE MULLION SPAN AND THE COLUMN CONTAINING THE TRIBUTARY WIDTH, READ THE MULLION LOAD RATING GIVEN IN PSF. THE MULLION LOAD RATING MUST BE EQUAL TO OR GREATER THAN THE DESIGN LOAD REQUIREMENT DETERMINED IN STEP 1 ABOVE.

FOR ANCHORING GLAZING PRODUCTS TO THE MULLION, ANCHOR SIZE AND SPACING SHALL BE AS SPECIFIED IN ONE OF THE FOLLOWING:

1. SUBSTITUTE (1 FOR 1) 1/4"-14 SELF-DRILLING SCREWS FOR THE FASTENERS SHOWN IN THE INDIVIDUAL GLAZING PRODUCT APPROVAL.
2. SUBSTITUTE #8-18 PANHEAD SELF-DRILLING SCREWS FOR THE FASTENERS SHOWN IN THE INDIVIDUAL GLAZING PRODUCT APPROVAL. MAXIMUM FASTENER SPACING ALLOWED IS 6" FROM EACH END AND AT 15" O.C. MAX. SPACING.

NOTE: A MINIMUM OF 3 THREADS OF THE SELF-DRILLING SCREWS MUST PROTRUDE THROUGH THE WALL OF THE MULLION. THIS SECTION VIEW IS SHOWN FOR ILLUSTRATIVE PURPOSES; OTHER FRAME SECTIONS OF TDI APPROVED WINDOWS BY ALSIDE WINDOWS CAN BE USED IN THIS FASHION.

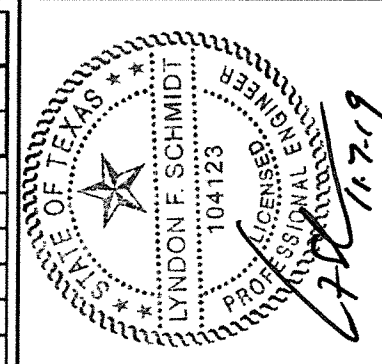

Documents Prepared By: Lyndon F. Schmidt, P.E.
TEXAS P.E. #104123

RW BUILDING CONSULTANTS, INC.
P.O. Box 230 Vairico FL 33595
Phone No.: 813.659.9197

TEXAS BOARD OF PROFESSIONAL ENGINEERS
CERTIFICATE OF REGISTRATION # F-11852

PRODUCT:	STRUCTURAL TRANSOM	
PART OR ASSEMBLY:	MULLION LOAD TABLE FOR WOOD SCREW ANCHORS	
DATE:	8/08/13	
SCALE:	NTS	
DWG. BY:	JK	
CHK. BY:	LFS	
DRAWING NO.:	TX-4359	
SHEET	2 OF 4	
NO.	DATE	REVISIONS
1	11/06/19	UPDATE TO 2018 IBC/IRC
		LFS
		BY

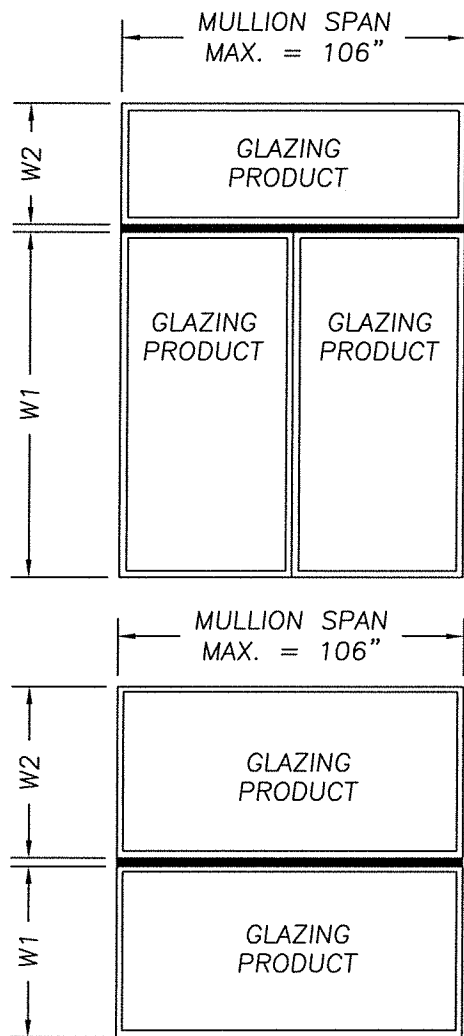

$$\text{TRIBUTARY WIDTH} = \frac{W1 + W2}{2}$$

CONCRETE SCREW ANCHORS	"I" SERIES STRUCTURAL TRANSOM MULLION LOAD TABLE (PSF)													
	TRIBUTARY WIDTH													
	24"	28"	32"	36"	40"	42"	44"	48"	50"	52"	54"	56"	60"	
106"	33.00	29.00	25.00	22.00	20.00	19.00	18.00	16.00	16.00	15.00	15.00	14.00	13.00	
100"	36.00	30.00	27.00	24.00	21.00	20.00	19.00	18.00	17.00	16.00	16.00	15.00	14.00	
96"	37.00	32.00	28.00	25.00	22.00	21.00	20.00	18.00	18.00	17.00	16.00	16.00	15.00	
92"	39.00	33.00	29.00	26.00	23.00	22.00	21.00	19.00	18.00	18.00	17.00	16.00	15.00	
88"	40.00	35.00	30.00	27.00	24.00	23.00	22.00	20.00	19.00	18.00	18.00	17.00	16.00	
86"	41.00	35.00	31.00	27.00	25.00	23.00	22.00	20.00	20.00	19.00	18.00	17.00	16.00	
84"	42.00	36.00	32.00	28.00	25.00	24.00	23.00	21.00	20.00	19.00	19.00	18.00	17.00	
82"	43.00	37.00	32.00	29.00	26.00	25.00	23.00	21.00	21.00	20.00	19.00	18.00	17.00	
80"	45.00	38.00	33.00	30.00	27.00	25.00	24.00	22.00	21.00	20.00	20.00	19.00	18.00	
78"	46.00	39.00	34.00	30.00	27.00	26.00	25.00	23.00	22.00	21.00	20.00	19.00	18.00	
76"	47.00	40.00	35.00	31.00	28.00	27.00	25.00	23.00	22.00	21.00	21.00	20.00	18.00	
74"	48.00	41.00	36.00	32.00	29.00	27.00	26.00	24.00	23.00	22.00	21.00	20.00	19.00	
72"	50.00	42.00	37.00	33.00	30.00	28.00	27.00	25.00	24.00	23.00	22.00	21.00	20.00	
70"	51.00	44.00	38.00	34.00	30.00	29.00	28.00	25.00	24.00	23.00	22.00	22.00	20.00	
68"	52.00	45.00	39.00	35.00	31.00	30.00	28.00	26.00	25.00	24.00	23.00	22.00	21.00	
66"	54.00	46.00	40.00	36.00	32.00	31.00	29.00	27.00	26.00	25.00	24.00	23.00	21.00	
64"	56.00	48.00	42.00	37.00	33.00	32.00	30.00	28.00	27.00	25.00	25.00	24.00	22.00	
62"	58.00	49.00	43.00	38.00	34.00	33.00	31.00	29.00	27.00	26.00	25.00	24.00	23.00	
60"	60.00	51.00	45.00	40.00	36.00	34.00	32.00	30.00	28.00	27.00	26.00	25.00	24.00	
58"	62.00	53.00	46.00	41.00	37.00	35.00	33.00	31.00	29.00	28.00	27.00	26.00	24.00	
56"	64.00	55.00	48.00	42.00	38.00	36.00	35.00	32.00	30.00	29.00	28.00	27.00	25.00	
54"	66.00	57.00	50.00	44.00	40.00	38.00	36.00	33.00	32.00	30.00	29.00	28.00	26.00	
52"	69.00	59.00	51.00	46.00	41.00	39.00	37.00	34.00	33.00	31.00	30.00	29.00	27.00	
50"	72.00	61.00	54.00	48.00	43.00	41.00	39.00	36.00	34.00	33.00	32.00	30.00	28.00	
48"	75.00	64.00	56.00	50.00	45.00	42.00	40.00	37.00	36.00	34.00	33.00	32.00	30.00	
40"	75.00	75.00	67.00	60.00	54.00	51.00	49.00	45.00	43.00	41.00	40.00	38.00	36.00	

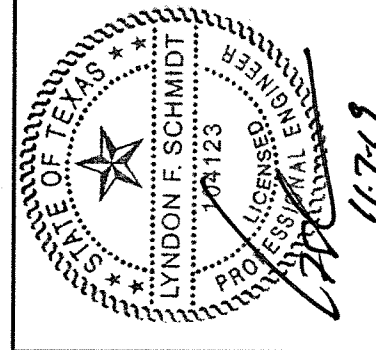

Documents Prepared By: Lyndon F. Schmidt, P.E.
TEXAS P.E. #104123

RW BUILDING CONSULTANTS, INC.
P.O. Box 230 Valrico FL 33595
Phone No.: 813.659.9197

TEXAS BOARD OF PROFESSIONAL ENGINEERS
CERTIFICATE OF REGISTRATION # F-11852

PRODUCT: STRUCTURAL TRANSOM

PART OR ASSEMBLY: MULLION LOAD TABLE FOR CONCRETE SCREW ANCHORS

NO.	DATE	REVISIONS
1	11/06/19	UPDATE TO 2018 IBC/IRC

DATE: 8/08/13

SCALE: NTS

DWG. BY: JK

CHK. BY: LFS

DRAWING NO.: TX-4359

SHEET 3 OF 4

INSTRUCTIONS FOR USE OF THE MULLION LOAD TABLE:

1. DETERMINE THE DESIGN LOAD REQUIREMENT FOR THE PARTICULAR OPENING AS SPECIFIED BY THE BUILDING DESIGNER (ARCHITECT OR ENGINEER OR RECORD).
2. FOR THE PARTICULAR OPENING, DETERMINE THE TRIBUTARY WIDTH AND MULLION SPAN. REFERENCE THE SKETCHES ON THIS SHEET FOR MULLION SPAN AND TRIBUTARY WIDTH DETERMINATION.
3. IN THE FIRST COLUMN OF THE TABLE, LOCATE THE MULLION SPAN. IN THE FIRST ROW OF THE TABLE, LOCATE THE TRIBUTARY WIDTH. AT THE INTERSECTION OF THE ROW CONTAINING THE MULLION SPAN AND THE COLUMN CONTAINING THE TRIBUTARY WIDTH, READ THE MULLION LOAD RATING GIVEN IN PSF. THE MULLION LOAD RATING MUST BE EQUAL TO OR GREATER THAN THE DESIGN LOAD REQUIREMENT DETERMINED IN STEP 1 ABOVE.

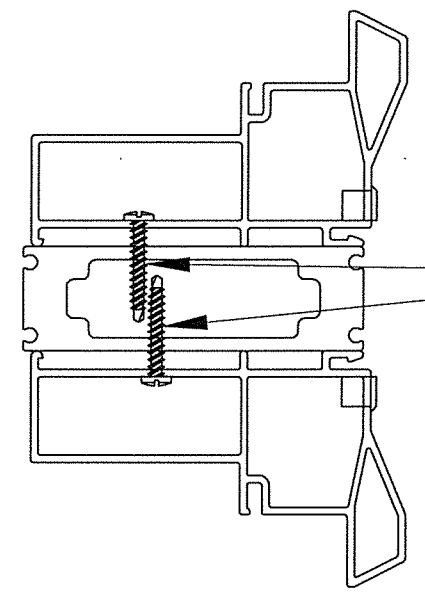

SECTION THRU MULLION & FRAME

FOR ANCHORING GLAZING PRODUCTS TO THE MULLION, ANCHOR SIZE AND SPACING SHALL BE AS SPECIFIED IN ONE OF THE FOLLOWING:

1. SUBSTITUTE (1 FOR 1) 1/4"-14 SELF-DRILLING SCREWS FOR THE FASTENERS SHOWN IN THE INDIVIDUAL GLAZING PRODUCT APPROVAL.
2. SUBSTITUTE #8-18 PANHEAD SELF-DRILLING SCREWS FOR THE FASTENERS SHOWN IN THE INDIVIDUAL GLAZING PRODUCT APPROVAL. MAXIMUM FASTENER SPACING ALLOWED IS 6" FROM EACH END AND AT 15" O.C. MAX. SPACING.

NOTE: A MINIMUM OF 3 THREADS OF THE SELF-DRILLING SCREWS MUST PROTRUDE THROUGH THE WALL OF THE MULLION. THIS SECTION VIEW IS SHOWN FOR ILLUSTRATIVE PURPOSES; OTHER FRAME SECTIONS OF TDI APPROVED WINDOWS BY ALSIDE WINDOWS CAN BE USED IN THIS FASHION.

R:\Clients\Associated PERMANENT.B - Texas Dept of Ins\Mullions\TDI-Series I Structural Mullion\TDI 2018 IBC RENEWAL\TX-4359.dwg, 4

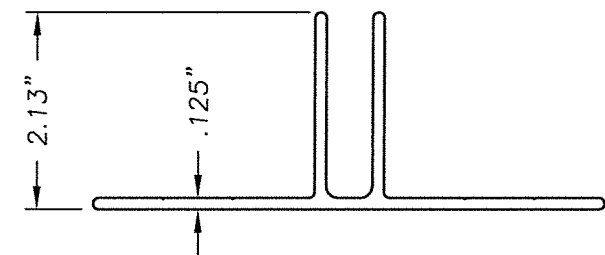
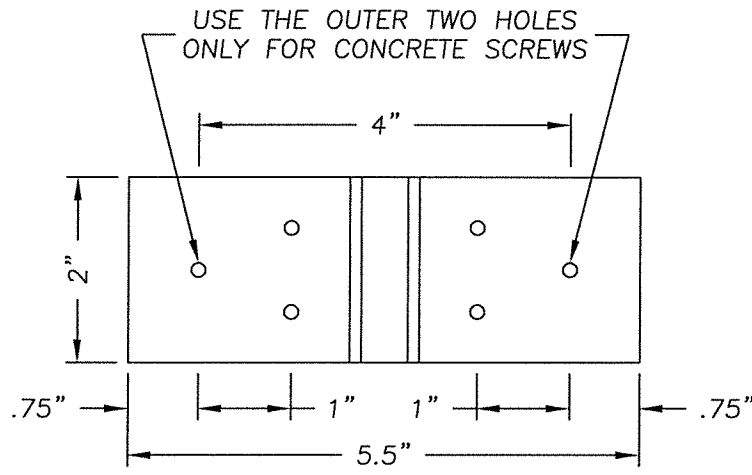

MULLION ANCHOR BRACKET
MAT'L: 6063-T6

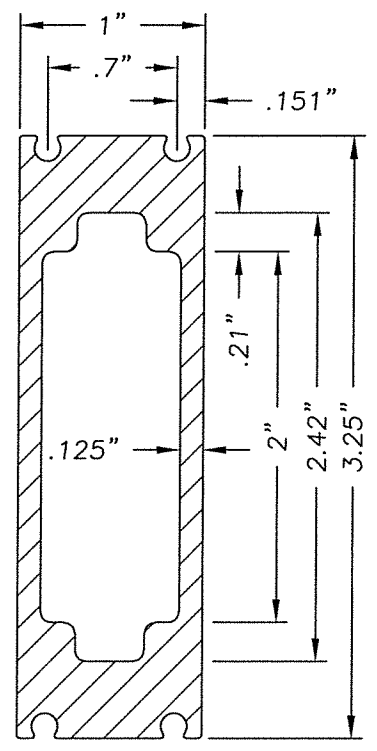

MULLION
MAT'L: 6063-T6

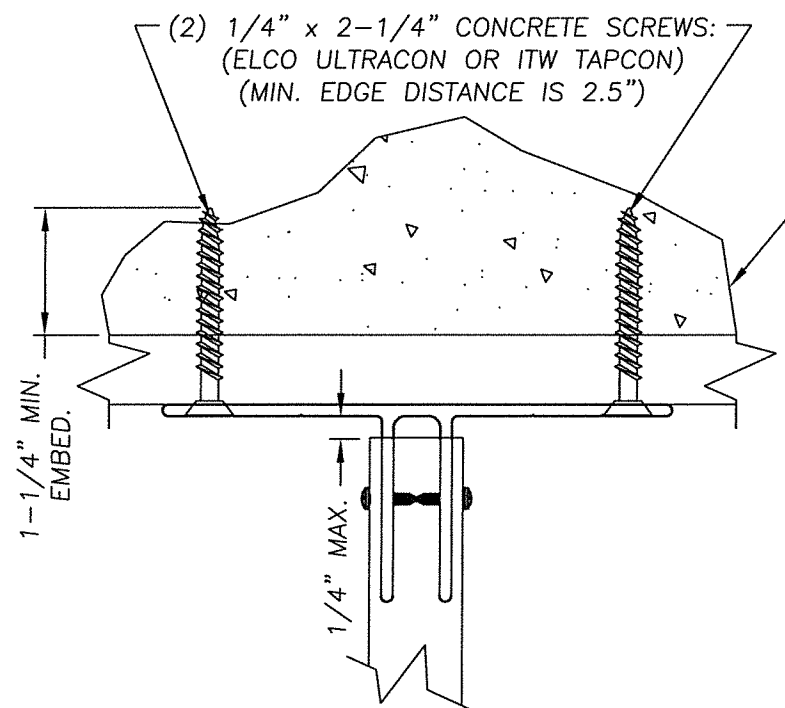

ANCHOR THROUGH 1X BUCK
USING 1/4" X 2-1/4"
CONCRETE SCREWS

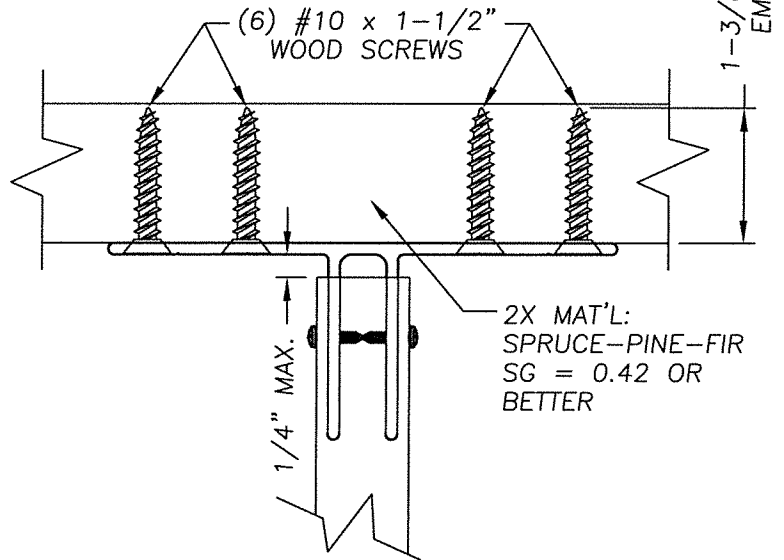

ANCHOR TO 2X STUD OR TO 2X BUCK

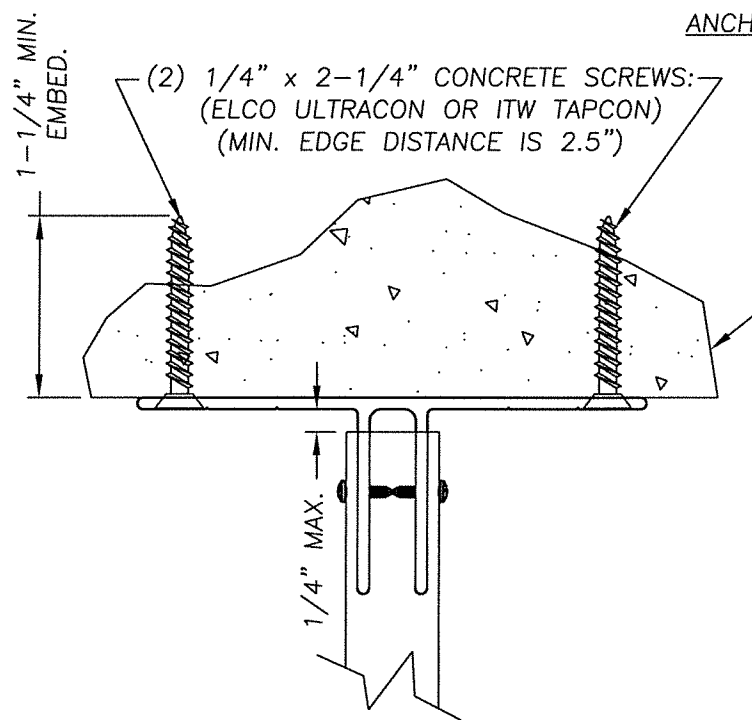

ANCHOR TO MASONRY
USING 1/4" X 2-1/4"
CONCRETE SCREWS

3,000 PSI CONCRETE
CONFORMING TO ACI
301 OR HOLLOW
BLOCK CONFORMING
TO ASTM C90

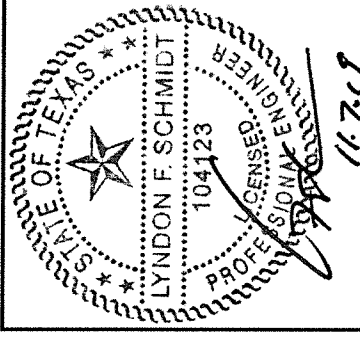

Documents Prepared By: Lyndon F. Schmidt, P.E.
TEXAS P.E. #104123

RW BUILDING CONSULTANTS, INC.
P.O. Box 230 Valrico FL, 33595
Phone No.: 813.659.9197

TEXAS BOARD OF PROFESSIONAL ENGINEERS
CERTIFICATE OF REGISTRATION # F-11852

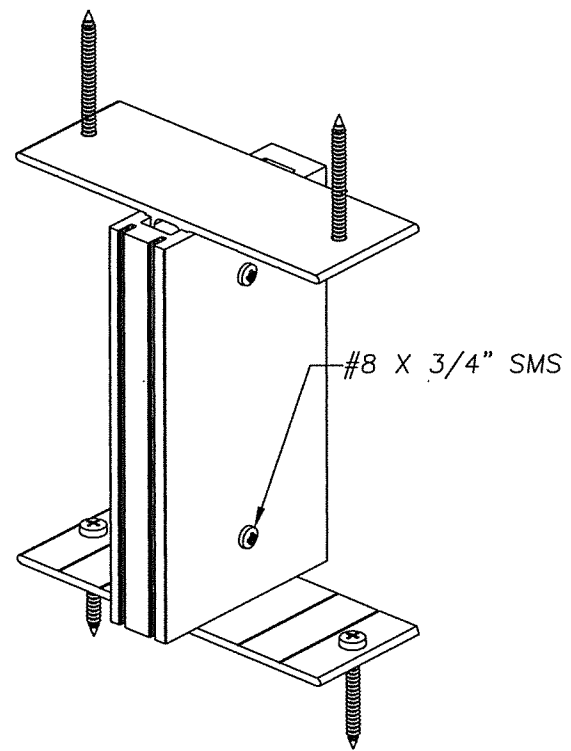

BASIC MULLION BRACKET ANCHORING
FOR CONCRETE SCREW CONNECTIONS

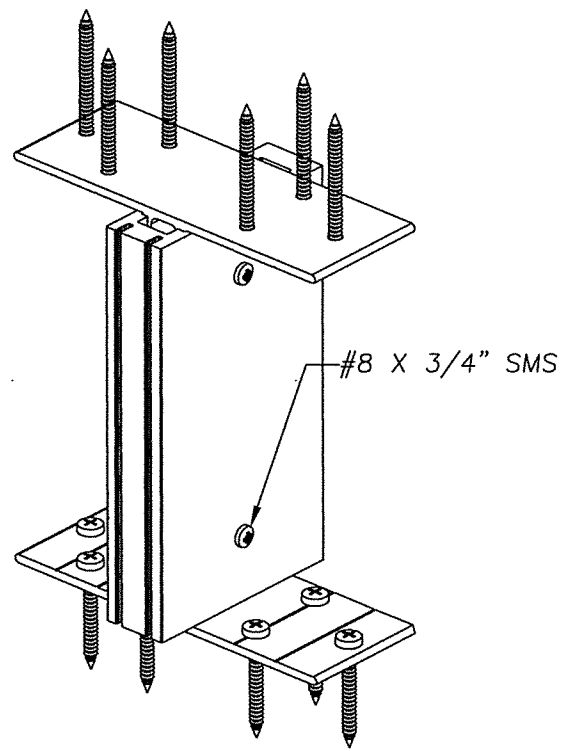

BASIC MULLION BRACKET ANCHORING
FOR WOOD SCREW CONNECTIONS

PRODUCT:	STRUCTURAL TRANSOM
PART OR ASSEMBLY:	MULLION SECTION & ANCHOR DETAILS

NO.	DATE	BY	REVISIONS
1	11/06/19	LFS	UPDATE TO 2018 IBC/IRC

DATE:	8/08/13
SCALE:	NTS
DWG. BY:	JK
CHK. BY:	LFS
DRAWING NO.:	TX-4359
SHEET	4 OF 4

© 2013 R.W. BUILDING CONSULTANTS INC.