

ABBREVIATIONS:

- B.O. - BLANK OFF
- CF - CHANNEL FRAME
- CONT. - CONTINUOUS
- C-C - CENTER TO CENTER
- DIM - DIMENSION
- FLG - FLANGE
- FF - FLANGED FRAME
- HDG - HOT DIP GALVANIZED
- H.V.B.S. - HIDDEN VERTICAL BLADE SUPPORT
- H.H.B.S. - HIDDEN HORIZONTAL BLADE SUPPORT
- HWH - HEX WASHER HEAD
- L.D. - LOUVER DIMENSION
- MAX. - MAXIMUM
- MIN. - MINIMUM
- NOM. - NOMINAL
- N.T.E. - NOT TO EXCEED
- N.T.S. - NOT TO SCALE
- O/C - ON CENTER
- OPP. - OPPOSITE
- N.I.C. - NOT IN CONTRACT
- R.O. - ROUGH OPENING
- REF - REFERENCE
- SHT - SHEET
- S.S. - SHIP SECTION
- S.S.D. - SHIP SECTION DIMENSION
- S.D.S. - SELF DRILLING SCREW
- SIM - SIMILAR
- STL - STEEL
- TYP. - TYPICAL
- U.N.O. - UNLESS NOTED OTHERWISE

#10 X 3/4" SD SCREW
4" O/C FULL PERIMETER
JOINING LOUVERS.

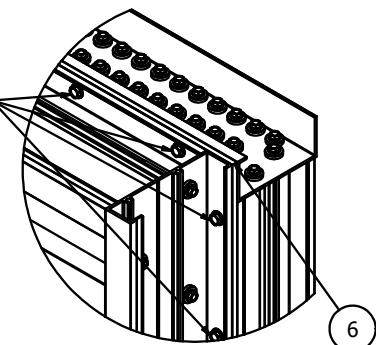

DETAIL 1
LOUVER ASSEMBLY

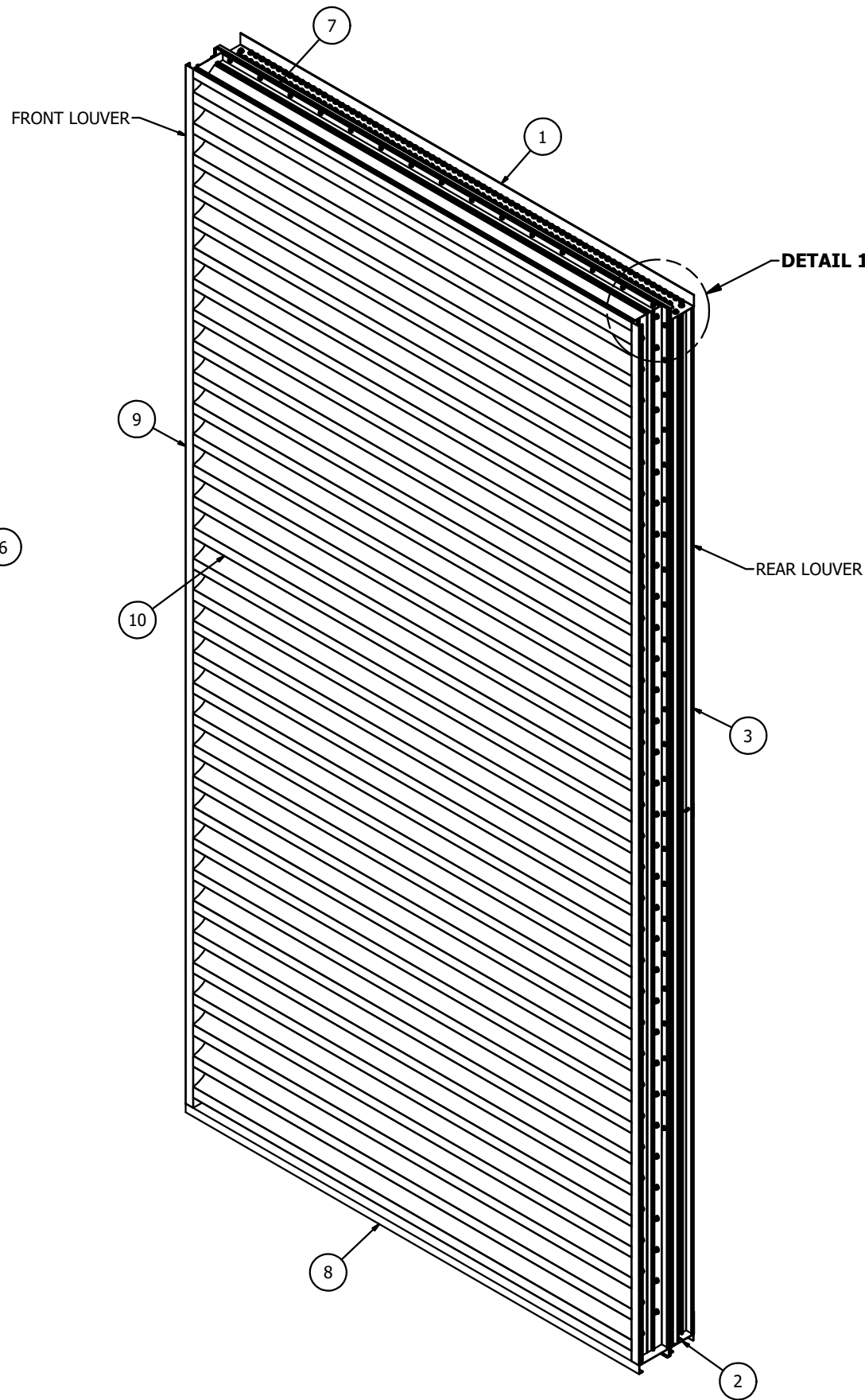

NOTES:

1. THE **HZ700MD** COMPLIES WITH THE REQUIREMENTS OF THE 2018 IBC. THE **HZ700MD** HAS BEEN TESTED IN ACCORDANCE WITH & QUALIFIED TO FLORIDA PROTOCOLS **TAS-201, 202, & 203** FOR LARGE MISSILE IMPACT, UNIFORM PRESSURE, CYCLIC WIND PRESSURE; **AMCA 540** FOR **LEVEL E (ENHANCED PROTECTION)** MISSILE IMPACT; & **AMCA 550** FOR HIGH VELOCITY WIND DRIVEN RAIN.
2. QUALIFICATIONS TO **AMCA 550** ALLOWS THIS LOUVER TO BE INSTALLED IN A LOCATION WHERE THE ROOM BEHIND THE LOUVER IS NOT DESIGNED TO DRAIN WATER PENETRATING INTO THE ROOM & THE ROOM DOES NOT HOUSE WATER RESISTANT/PROOF EQUIPMENT, COMPONENTS, OR SUPPLIES.
3. THIS LOUVER SYSTEM IS APPROVED FOR APPLICATIONS WITH **DESIGN PRESSURES OF +/- 130 PSF** OR LESS. THIS LOUVER SYSTEM IS NON-BEARING AND IS NOT DESIGNED TO WITHSTAND BUILDING DEAD LOADS.
4. SECTIONS OR ASSEMBLIES MAY BE STACKED VERTICALLY PROVIDING A SUITABLE STRUCTURAL MEMBER, DESIGNED & INSTALLED BY OTHERS, IS BETWEEN EACH STACKED LOUVER TO CARRY THE FULL LOAD OF THE UPPER LOUVER, SO THAT NO LOUVER TAKES THE LOAD OF THE OTHER.
5. THIS LOUVER ATTACHES ONLY AT THE HEAD & SILL TO THE SUBSTRATE. NO ATTACHMENT AT JAMBS. **SEE SHEET-07 & -08** FOR INSTALLATION PARTS & DETAILS. REQUIREMENTS GIVEN IN "**SUBSTRATE FASTENER TABLE**" ARE AS NEEDED FOR ANCHORAGE ONLY AND (N.I.C.).
6. MAXIMUM SINGLE SECTION SIZE FOR RECTANGLES ARE **60" WIDE X 120" HIGH**. UNLIMITED WIDTH CAN BE ACCOMPLISHED BY PLACING SINGLE SECTIONS SIDE-BY-SIDE.
7. ALL WELDED ATTACHMENTS REQUIRE A MINIMUM FILLER OF 4043 ALUMINUM ALLOY WITH A MINIMUM TENSILE STRENGTH OF 24KSI.
8. EXTRUDED ALUMINUM H.H.B.S. CHANNEL IS FACTORY CUT TO FIT BETWEEN EACH BLADE. THE H.H.B.S.CHANNEL IS SCREWED TO EVERY 3RD BLADE AND AT BOTH JAMBS FRAMES. THE H.H.B.S. CHANNEL IS REQUIRED FOR ANY LOUVER ASSEMBLY EXCEEDING **60" HIGH** & EQUALLY SPACED BETWEEN HEAD & SILL FRAMES.
9. **SQUARE BALLOONS** INDICATE **SHIP LOOSE PARTS**.

HZ700MD COMBINATION RECTANGLE LOUVER
N.T.S.
(CF) 60"W X 120"H SHOWN

PARTS LIST / REAR LOUVER (CF)

ITEM	DESCRIPTION	MATERIAL
1	HEAD FRAME	EXT ALUM 6063-T6
2	SILL FRAME	EXT ALUM 6063-T6
3	JAMB FRAME	EXT ALUM 6063-T6
4	LOUVER BLADE	EXT ALUM 6063-T6
5	H.H.B.S.	EXT ALUM 6063-T6
6	GSK STP NEOP .25 X .50	NEOPRENE

PARTS LIST / FRONT LOUVER (CF)

ITEM	DESCRIPTION	MATERIAL
7	HEAD FRAME	EXT ALUM 6063-T6
8	SILL FRAME	EXT ALUM 6063-T6
9	JAMB FRAME	EXT ALUM 6063-T6
10	LOUVER BLADE	EXT ALUM 6063-T6
11	WATERSTOP	EXT ALUM 6063-T5

PARTS LIST / FRONT LOUVER (FF)

ITEM	DESCRIPTION	MATERIAL
12	FLANGED HEAD FRAME	EXT ALUM 6063-T6
13	FLANGED SILL FRAME	EXT ALUM 6063-T6
14	FLANGED JAMB FRAME	EXT ALUM 6063-T6

INSTALLATION PARTS

ITEM	DESCRIPTION	MATERIAL
15	CONT. RETAINING ANGLE 2" X 2" X 1/4"	EXT ALUM 6063-T6
16	SUBSTRATE FASTENER (N.I.C.)	(SEE SHEETS 07 & 08)
17	SCR 1/4"-20 X 1-1/2" HWH TEK3	ZC
18	UNIVERSAL SLEEVE - MIN. 1/8" THK PLATE	ALUM 5005-H34
19	SPL PLT LVR ALUM 2X4X.125	ALUM 3003-H14
20	CONT. RETAINING ZEE - 1/4" THK PLT	FORMED ALUM 5005-H34
21	CONT. RETAINING ANGLE - 1/4" X 2"	FORMED ALUM 3003-H14
22	CONT. RETAINING ANGLE - 1/4" X 3" X 5"	FORMED ALUM 3003-H14
23	CONT. STIFFENER PLT - 1/8" X 5"	ALUM 5005-H34
24	CONT. STIFFENER PLT - 1/8" X 4"	ALUM 5005-H34

DRAWING SHEET INDEX:

- SHEET 01** - STANDARD LOUVER SPECIFICATIONS
- SHEET 02** - MULTI-SECTION (CF) ASSEMBLY FRONT VIEW
- SHEET 03** - MULTI-SECTION (CF) ASSEMBLY BACK VIEW
- SHEET 04** - MULTI-SECTION (FF) ASSEMBLY FRONT VIEW
- SHEET 05** - MULTI-SECTION (FF) ASSEMBLY BACK VIEW
- SHEET 06** - UNIVERSAL SLEEVE ASSEMBLY & INSTALLATION
- SHEET 07** - LOUVER INSTALL / RETAINING SINGLE ANGLE
- SHEET 08** - LOUVER INSTALL / RETAINING ZEE & DOUBLE ANGLE
- SHEET 09** - LOUVER FRAME PROFILES
- SHEET 10** - INSTALL PARTS PROFILES

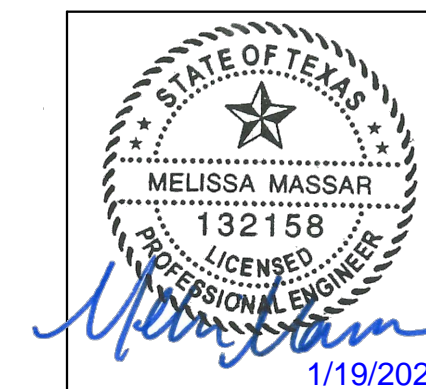

MELISSA MASSAR, P.E.
NO. 132158

AUTHOR	DKF	9/24/2020	 3900 Doctor Greaves Rd, Grandview, MO 64030 PROPRIETARY AND CONFIDENTIAL	
CHECKED	E-R	9/27/2020		
APPROVED	TCB	10/28/2020		
APPROVED	MMM	10/30/2020		
Tolerances	Unless Stated Otherwise Use WQ-007, WQ-008		PRODUCT	HZ700MD / WIND-DRIVEN RAIN RESISTANT LOUVER
Fractions	±1/16		TITLE	STANDARD LOUVER SPECIFICATIONS
Two Decimals	±0.020		SIZE	B
Three Decimals	±0.010		DWG NO	60-022580-00B
Angle Dimensions	±2'		SCALE	NONE
	ECN		INVENTOR	SHEET 1 OF 10

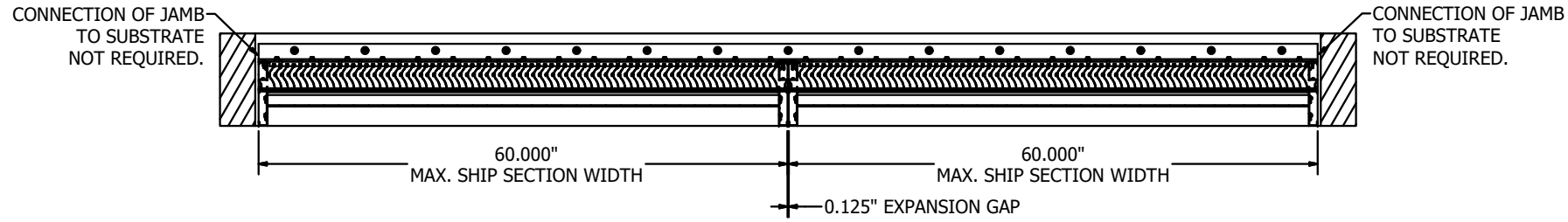

SECTION B-B

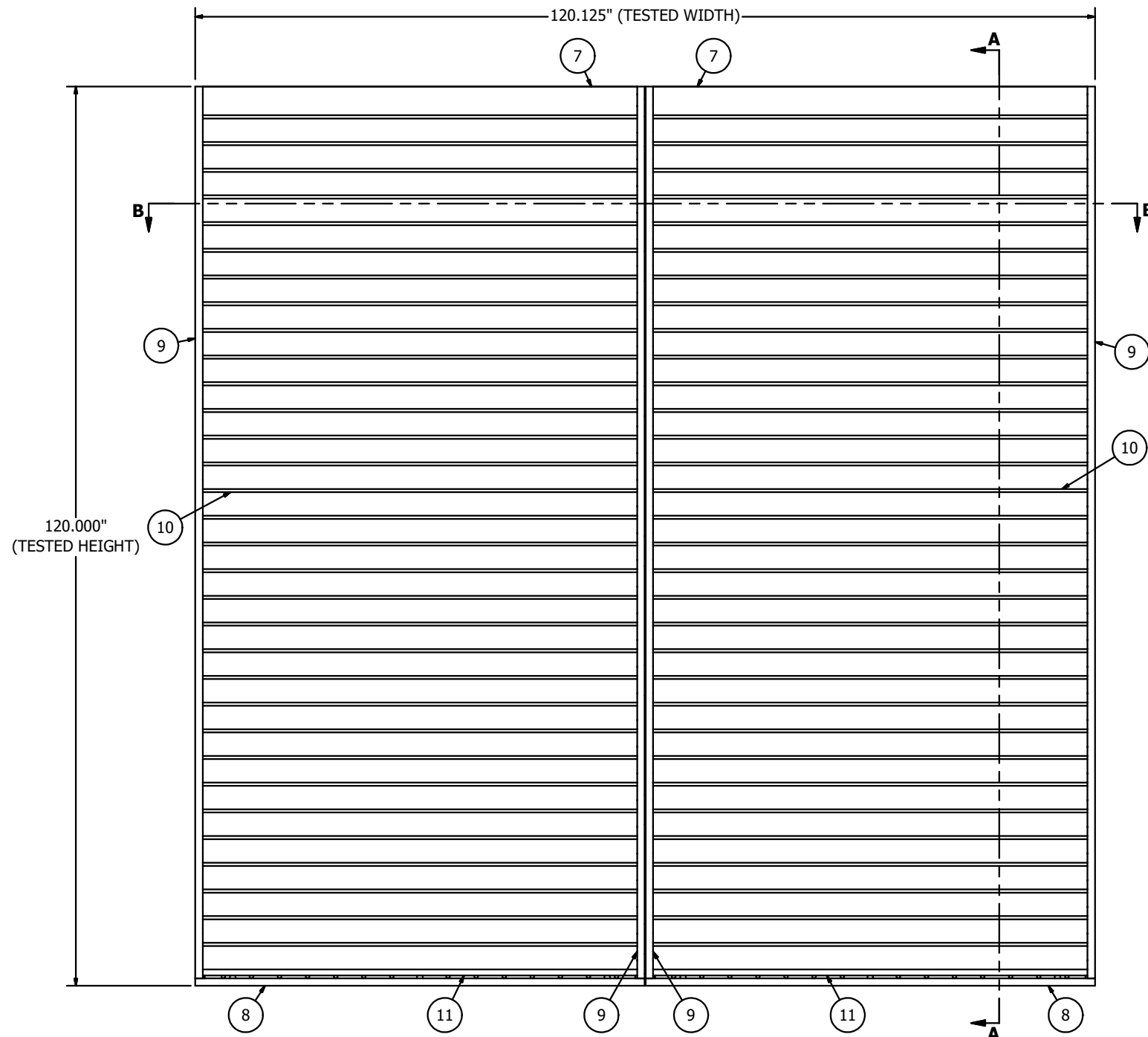

MULTI-SECTION ASSEMBLY - CHANNEL FRAME (FRONT) LOUVER

N.T.S.
(SUBSTRATE & INSTALL PARTS NOT SHOWN FOR CLARITY)

FRONT VIEW

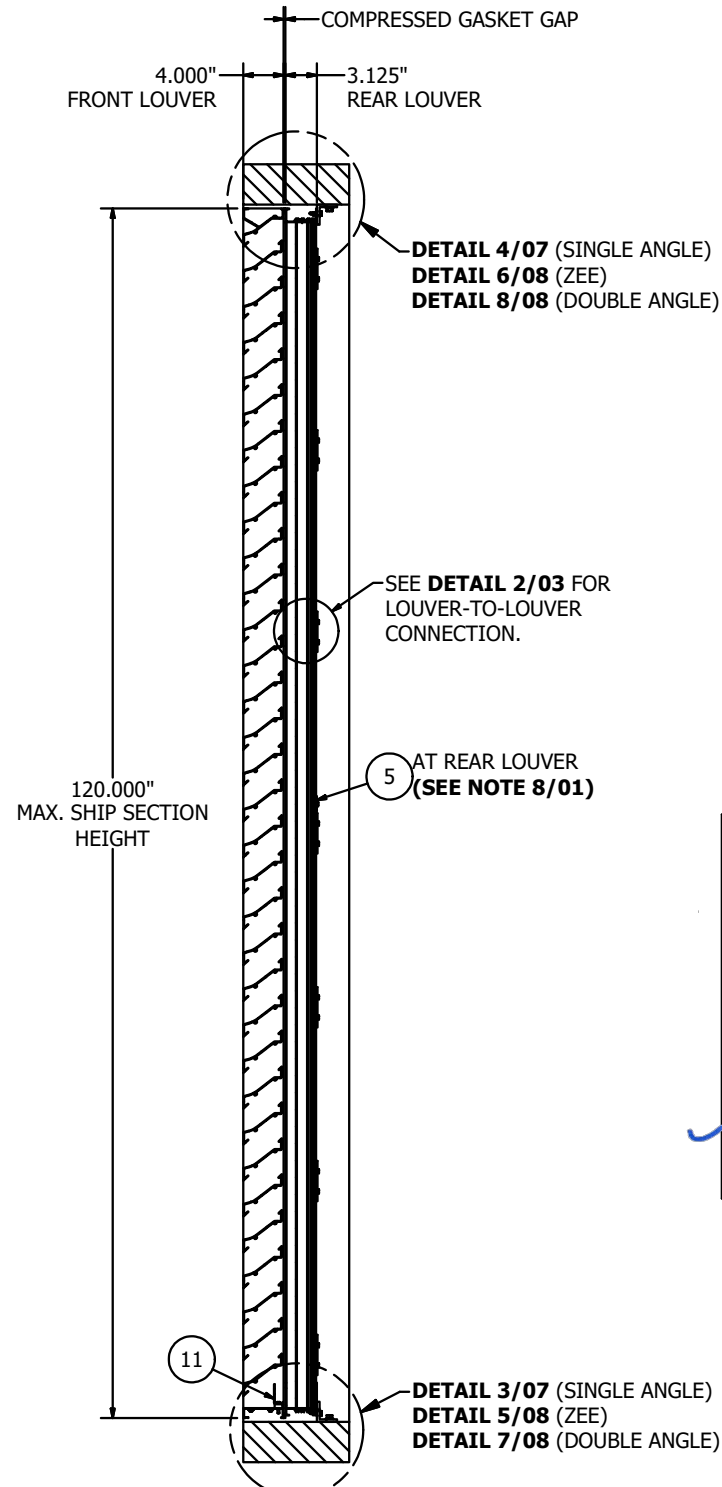

SECTION A-A



MELISSA MASSAR, P.E.
NO. 132158

AUTHOR	DKF	9/24/2020	 3900 Doctor Greaves Rd, Grandview, MO 64030 PROPRIETARY AND CONFIDENTIAL
CHECKED	E-R	9/27/2020	
APPROVED	TCB	10/28/2020	
APPROVED	MMM	10/30/2020	
MATERIAL	EXTRUDED ALUMINUM	TITLE	MULTI-SECTION (CF) ASSEMBLY FRONT VIEW
SIZE	B	DWG NO	60-022580-00B
ECN		SCALE	NONE
		INVENTOR	SHEET 2 of 10

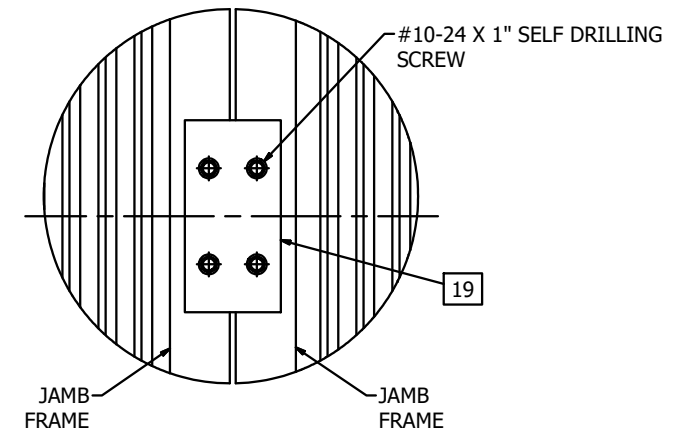
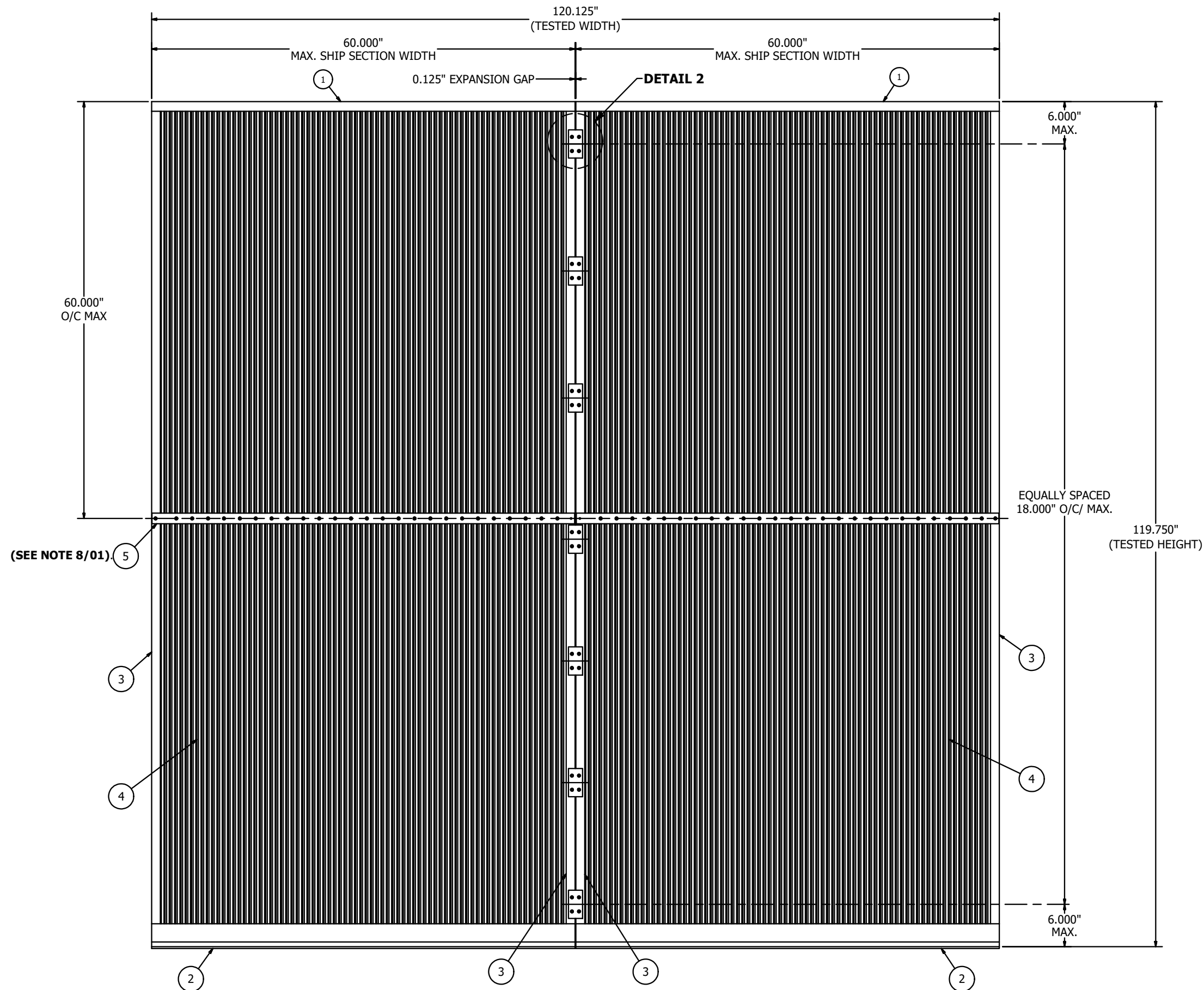

DETAIL 2
LOUVER-TO-LOUVER SPLICE

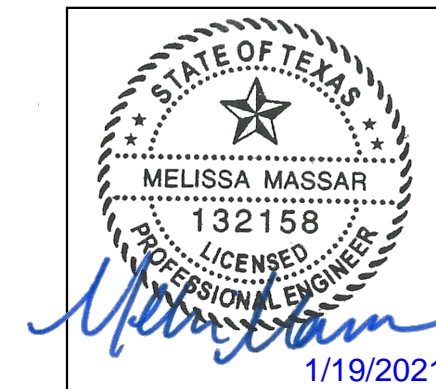

MELISSA MASSAR, P.E.
NO. 132158

MULTI-SECTION ASSEMBLY - CHANNEL FRAME (REAR) LOUVER

N.T.S.
(SUBSTRATE & INSTALL PARTS NOT SHOWN FOR CLARITY)

BACK VIEW

AUTHOR	DKF	9/24/2020	 3900 Doctor Greaves Rd, Grandview, MO 64030 PROPRIETARY AND CONFIDENTIAL
CHECKED	E-R	9/27/2020	
APPROVED	TCB	10/28/2020	
APPROVED	MMM	10/30/2020	
MATERIAL	EXTRUDED ALUMINUM	TITLE	MULTI-SECTION (CF) ASSEMBLY BACK VIEW
SIZE	B	DWG NO	60-022580-00B
SCALE	NONE	INVENTOR	SHEET 3 OF 10

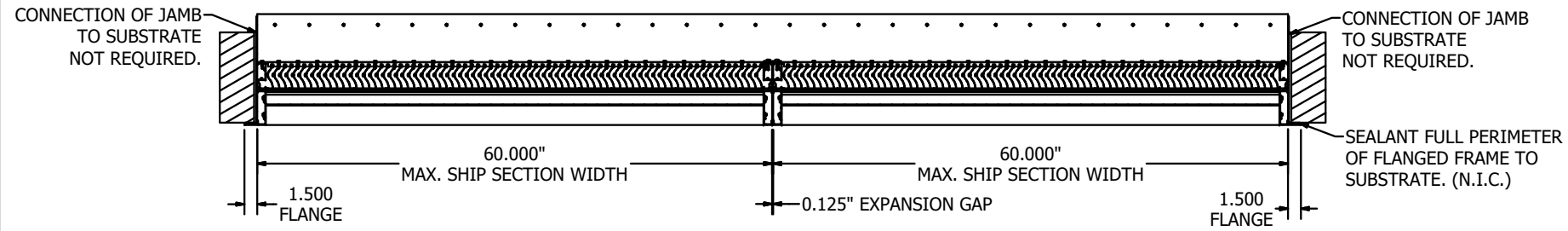

SECTION D-D

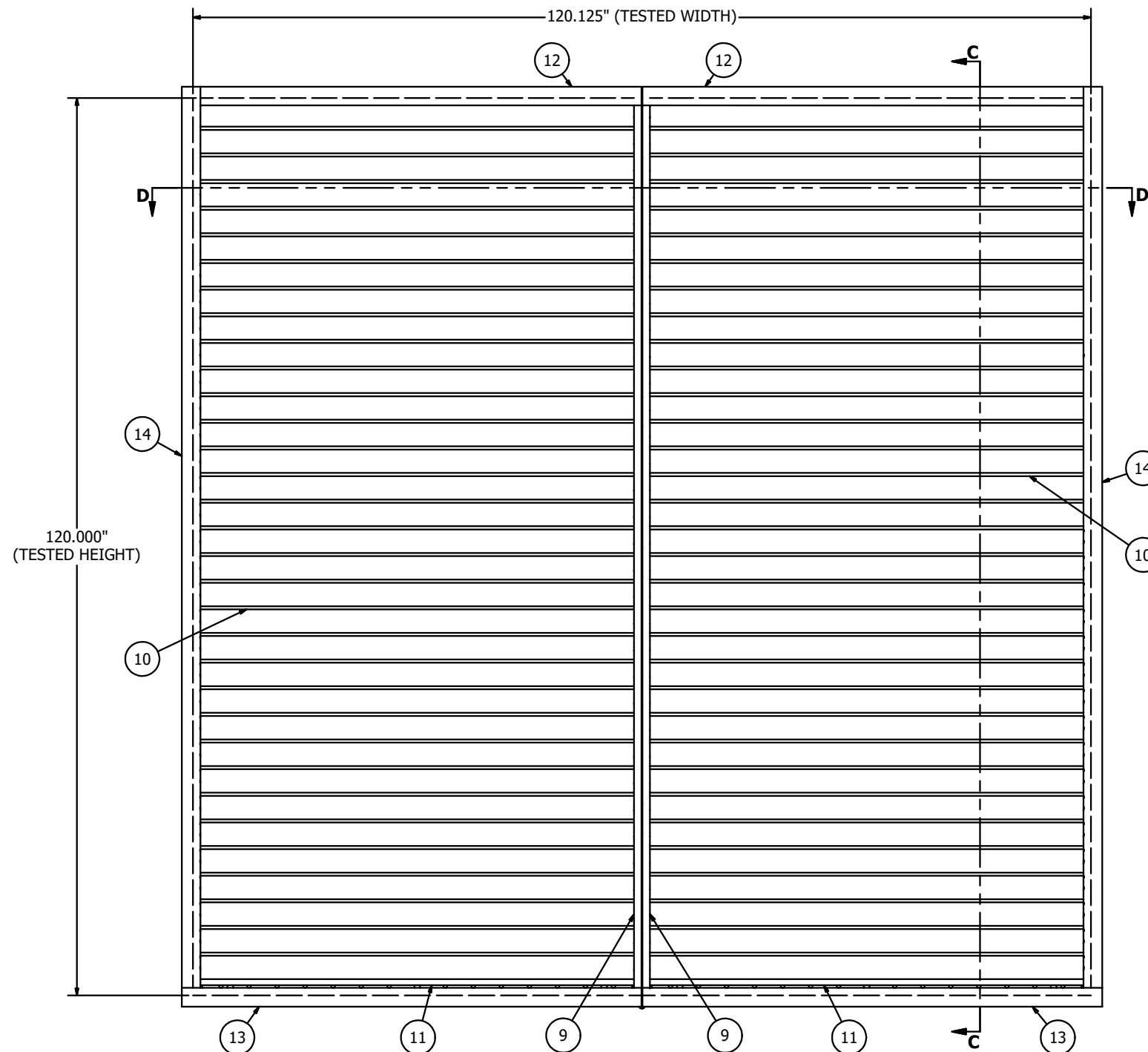

MULTI-SECTION ASSEMBLY - FLANGED FRAME (FRONT) LOUVER

N.T.S.
(SUBSTRATE & INSTALL PARTS NOT SHOWN FOR CLARITY)

FRONT VIEW

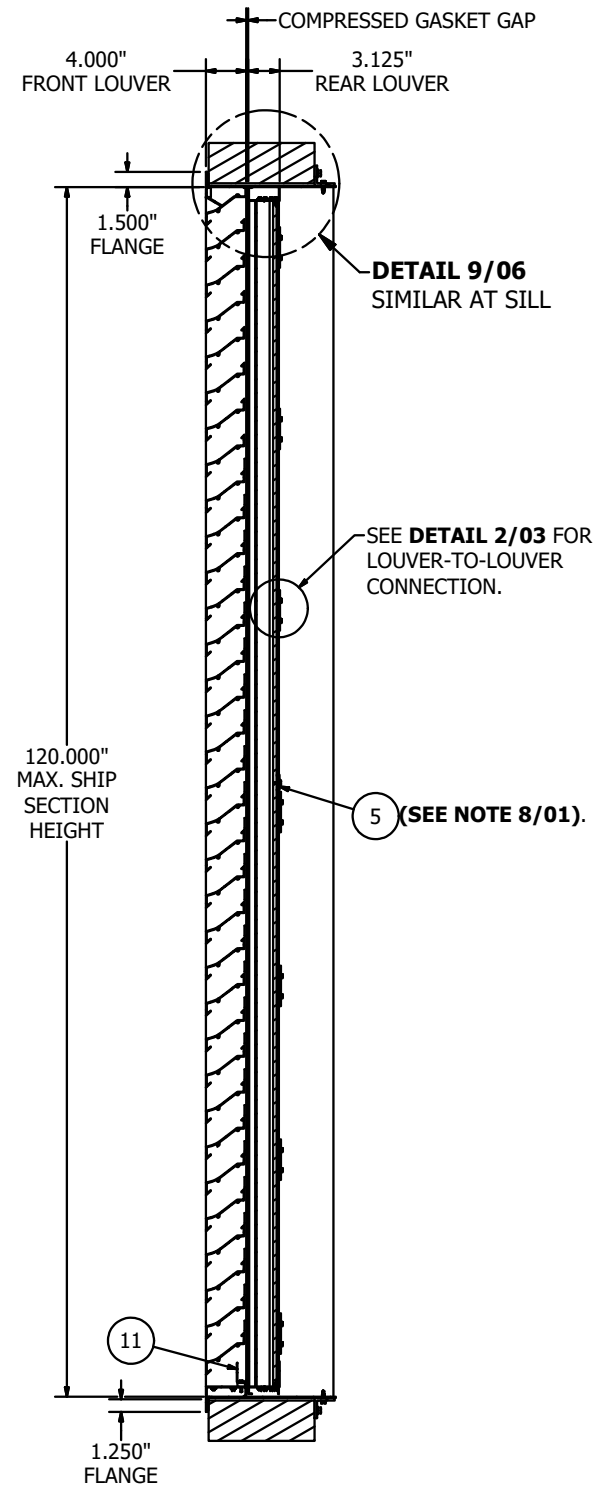

SECTION C-C



MELISSA MASSAR, P.E.
NO. 132158

AUTHOR	DKF	9/24/2020	 3900 Doctor Greaves Rd, Grandview, MO 64030 PROPRIETARY AND CONFIDENTIAL
CHECKED	E-R	9/27/2020	
APPROVED	TCB	10/28/2020	
APPROVED	MMM	10/30/2020	
MATERIAL	EXTRUDED ALUMINUM	TITLE	MULTI-SECTION (FF) ASSEMBLY FRONT VIEW
SIZE	B	DWG NO	60-022580-00B
SCALE	NONE	INVENTOR	SHEET 4 OF 10

120.125" (TESTED WIDTH)

1

DETAIL 2/03

1

FLANGE OF FRONT LOUVER

6.000" MAX.

60.000" O/C MAX

4

EQUALLY SPACED @ 18.000" O/C MAX

119.750" (TESTED HEIGHT)

(SEE NOTE 8/01)

5

3

3

4

6.000" MAX.

2

3

3

2

FLANGE OF FRONT LOUVER

MULTI-SECTION ASSEMBLY - CHANNEL FRAME (REAR) LOUVER

N.T.S.
(SUBSTRATE & INSTALL PARTS NOT SHOWN FOR CLARITY)

BACK VIEW

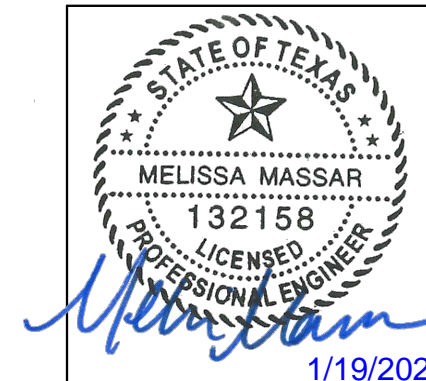

MELISSA MASSAR, P.E.
NO. 132158

AUTHOR	DKF	9/24/2020	 3900 Doctor Greaves Rd, Grandview, MO 64030 PROPRIETARY AND CONFIDENTIAL
CHECKED	E-R	9/27/2020	
APPROVED	TCB	10/28/2020	
APPROVED	MMM	10/30/2020	
MATERIAL	EXTRUDED ALUMINUM	TITLE	MULTI-SECTION (FF) ASSEMBLY BACK VIEW
SIZE	B	DWG NO	60-022580-00B
SCALE	NONE	INVENTOR	SHEET 5 OF 10

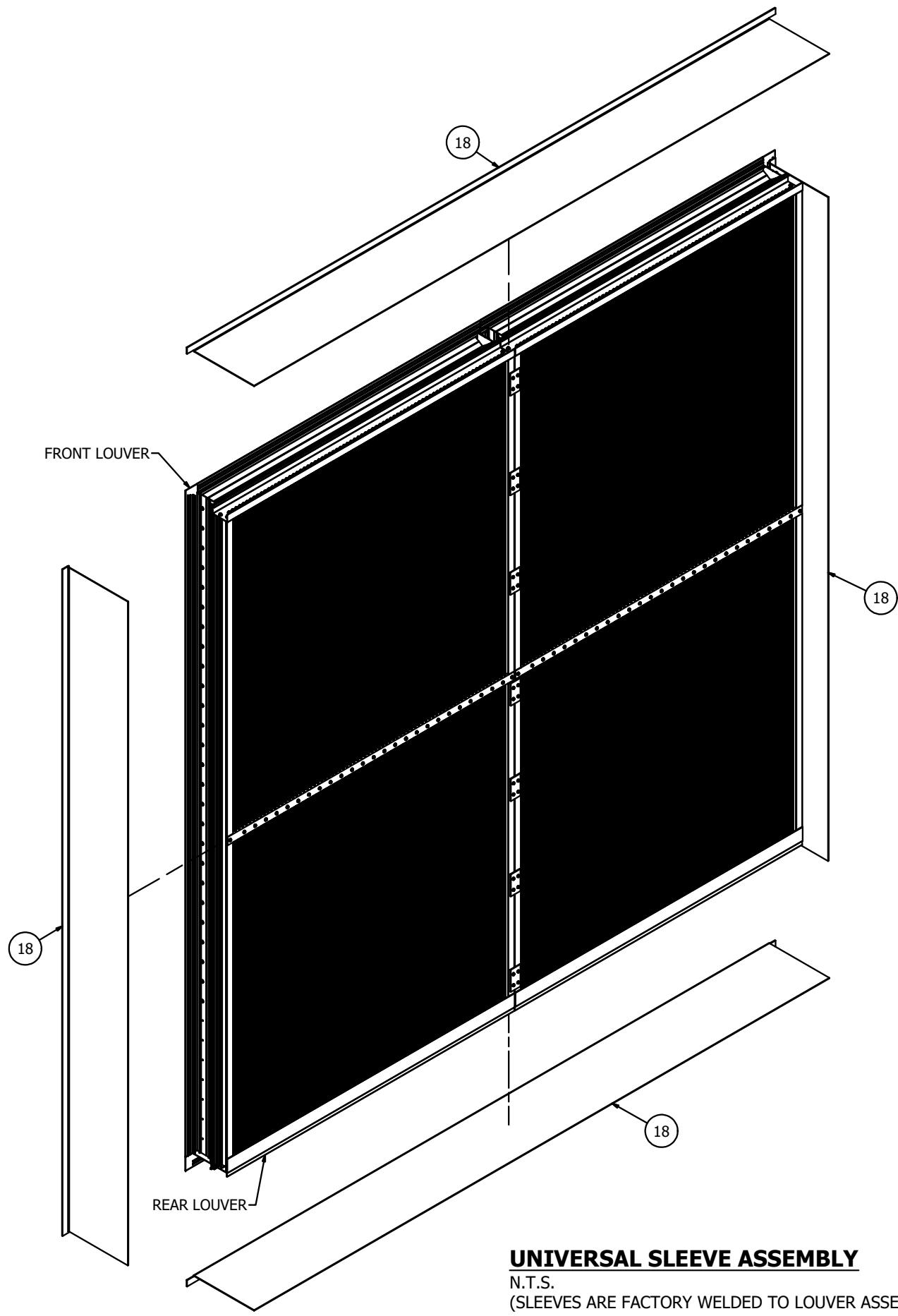

UNIVERSAL SLEEVE ASSEMBLY
 N.T.S.
 (SLEEVES ARE FACTORY WELDED TO LOUVER ASSEMBLIES)

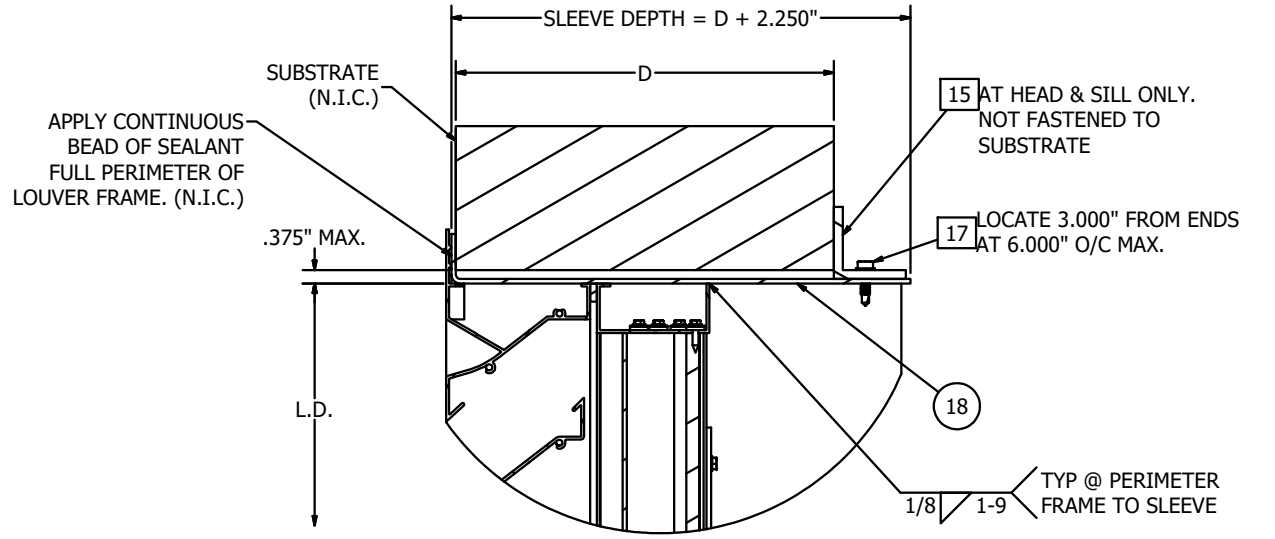

DETAIL 9
 RETAINING ANGLE INSTALL
 AT HEAD (SHOWN).
 SIMILAR AT SILL.

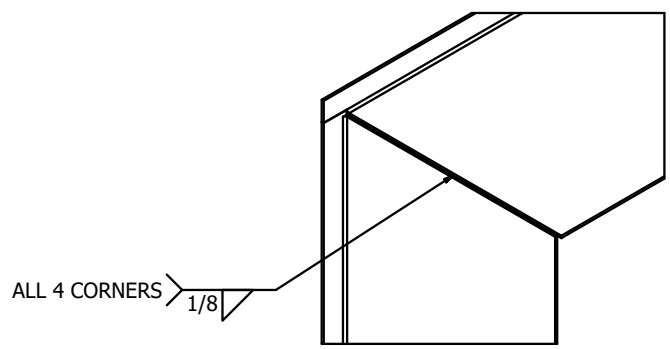

**UNIVERSAL SLEEVE
 CORNER WELDS**



AUTHOR	DKF	9/24/2020	 3900 Doctor Greaves Rd, Grandview, MO 64030 PROPRIETARY AND CONFIDENTIAL
CHECKED	E-R	9/27/2020	
APPROVED	TCB	10/28/2020	
APPROVED	MMM	10/30/2020	
MATERIAL	EXTRUDED ALUMINUM		PRODUCT: HZ700MD / WIND-DRIVEN RAIN RESISTANT LOUVER TITLE: UNIVERSAL SLEEVE ASSEMBLY
SIZE	B	DWG NO	60-022580-00B
SCALE	NONE	INVENTOR	SHEET 6 OF 10

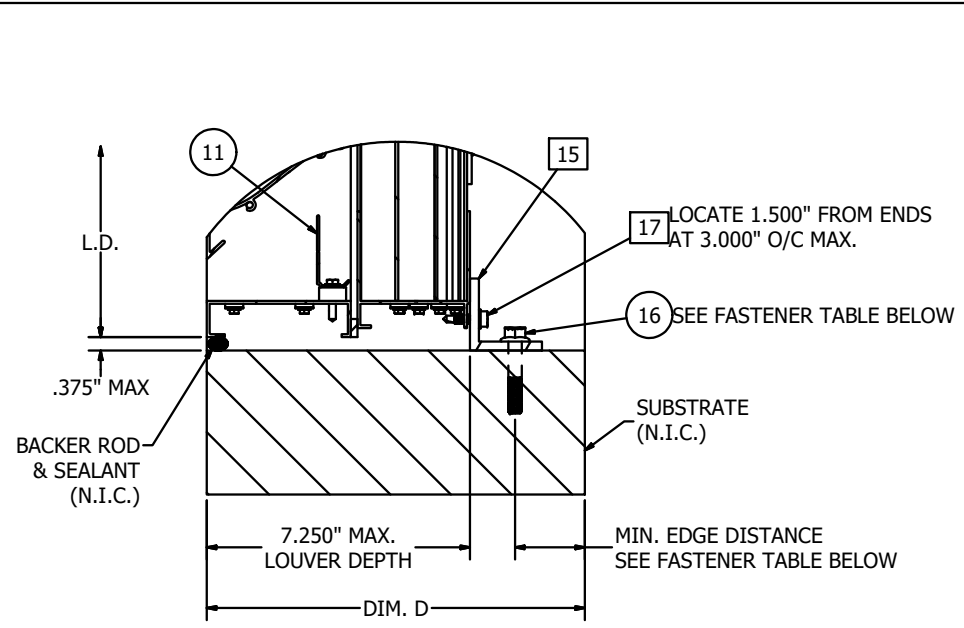

DETAIL 3
ANGLE INSTALL AT SILL

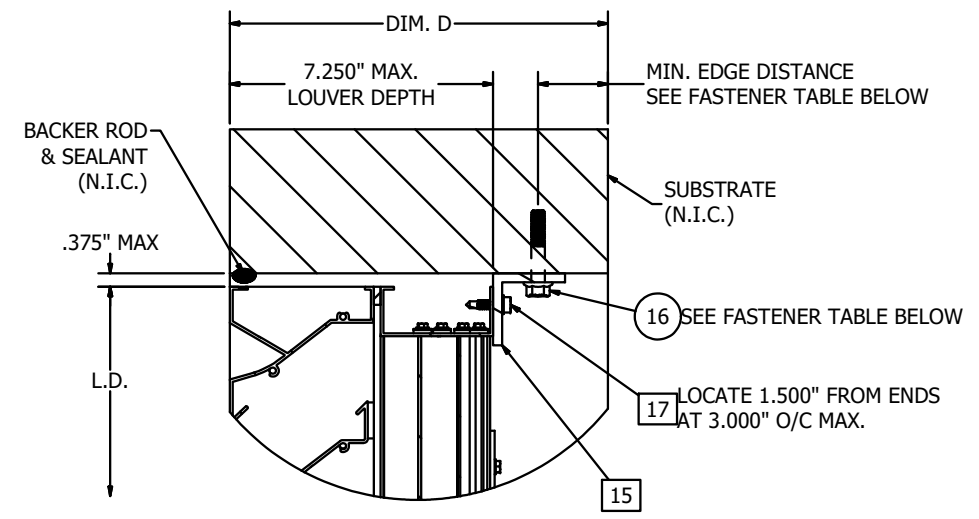
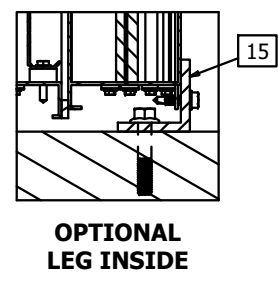

DETAIL 4
ANGLE INSTALL AT HEAD

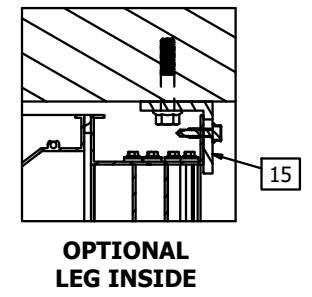

SUBSTRATE FASTENER TABLE (N.I.C.) / HZ700MD 130 PSF / SINGLE ANGLE INSTALLATION

SUBSTRATE TYPE	MIN. SUBSTRATE REQUIREMENTS	FASTENER TYPE	MAX. C/C SPACING AT HEAD / SILL	MIN. EMBEDMENT	MIN. EDGE DISTANCE
WOOD	3" THICK, 0.42 SPECIFIC GRAVITY	3/8-16 BOLT W/NUT, MIN A307 GRADE A	6"	3 THREADS BEYOND NUT	1-1/2"
		3/8" DIA. LAG SCREW, 2 1/2" LONG, MIN. A307 GRADE A	6"	2-1/4"	1-1/2"
STEEL	18 GA, 45 KSI TENSILE STRENGTH, 33KSI YIELD STRENGTH	1/4-20 BOLT W/NUT & WASHER MIN A307 GRADE A	6"	3 THREADS BEYOND NUT	1/2"
	12 GA, 45 KSI TENSILE STRENGTH, 33KSI YIELD STRENGTH	1/4-20 SELF-DRILLING SCREW W/ WASHER CARBON STEEL	3"	3 THREADS BEYOND SUBSTR. THICKNESS	1/2"
ALUMINUM	0.125" THICK, 20 KSI TENSILE STRENGTH, 15 KSI YIELD STRENGTH	1/4-20 BOLT W/NUT & WASHER MIN A307 GRADE A	6"	3 THREADS BEYOND NUT	1/2"
	0.1875" THICK, 20 KSI TENSILE STRENGTH, 15 KSI YIELD STRENGTH	1/4-20 SELF-DRILLING SCREW W/ WASHER CARBON STEEL	3"	3 THREADS BEYOND SUBSTR. THICKNESS	1/2"
CONCRETE	2500 PSI COMPRESSIVE STRENGTH	3/8" DIA. SIMPSON STRONG-TIE TITEN HD SCREW ANCHOR CARBON STEEL	6"	3-1/4"	3"
		3/8" DIA. DEWALT SCREW BOLT + SCREW ANCHOR CARBON STEEL	6"	3-1/4"	6"
		3/8" DIA. HILTI KWIK HUS-EZ SCREW ANCHOR CARBON STEEL	6"	3 1/4"	2 1/2"
		1/4" DIA. ELCO AGGRE-GATOR W/ WASHER 300 SERIES SS	3"	1-3/8"	1-1/2"
GROUT FILLED CMU	ASTM C-90 BLOCK, 1500 PSI GROUT COMPRESSIVE STRENGTH	3/8" DIA. SIMPSON STRONG-TIE TITEN HD SCREW ANCHOR CARBON STEEL	3"	2 -3/4"	4"
		3/8" DIA. DEWALT SCREW BOLT + SCREW ANCHOR CARBON STEEL	6"	3 1/4"	2"
		3/8" DIA. HILTI KWIK HUS-EZ SCREW ANCHOR CARBON STEEL	6"	3-1/4"	4"
		1/4" DIA. ELCO AGGRE-GATOR W/ WASHER 300 SERIES SS	3"	2"	2"

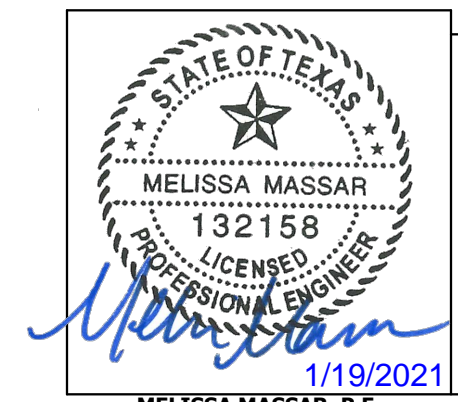

MELISSA MASSAR, P.E.
NO. 132158

AUTHOR	DKF	9/24/2020		3900 Doctor Greaves Rd, Grandview, MO 64030 PROPRIETARY AND CONFIDENTIAL
CHECKED	E-R	9/27/2020		
APPROVED	TCB	10/28/2020	PRODUCT: HZ700MD / WIND-DRIVEN RAIN RESISTANT LOUVER	
APPROVED	MMM	10/30/2020	MATERIAL: EXTRUDED ALUMINUM TITLE: LOUVER INSTALLATION DETAILS & FASTENING	
SIZE	B		DWG NO	60-022580-00B
SCALE	NONE		INVENTOR	SHEET 7 OF 10

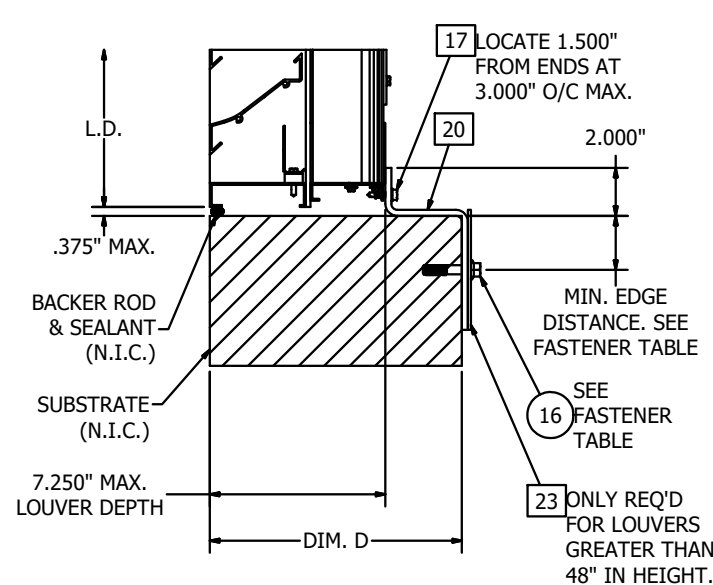

DETAIL 5
RETAINING ZEE INSTALLED AT SILL

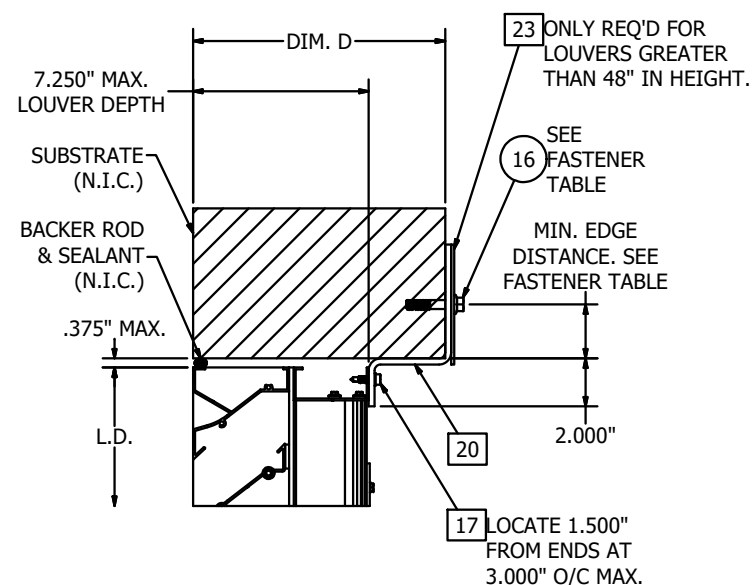

DETAIL 6
RETAINING ZEE INSTALLED AT HEAD

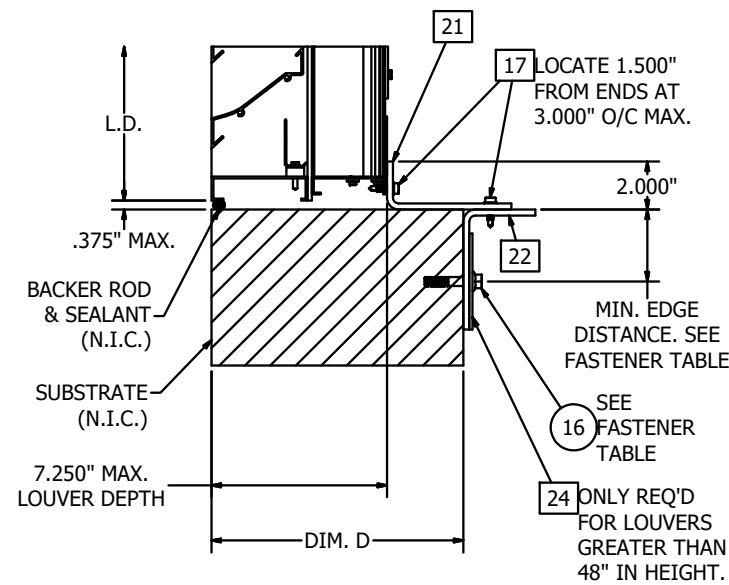

DETAIL 7
DOUBLE ANGLE INSTALLED AT SILL

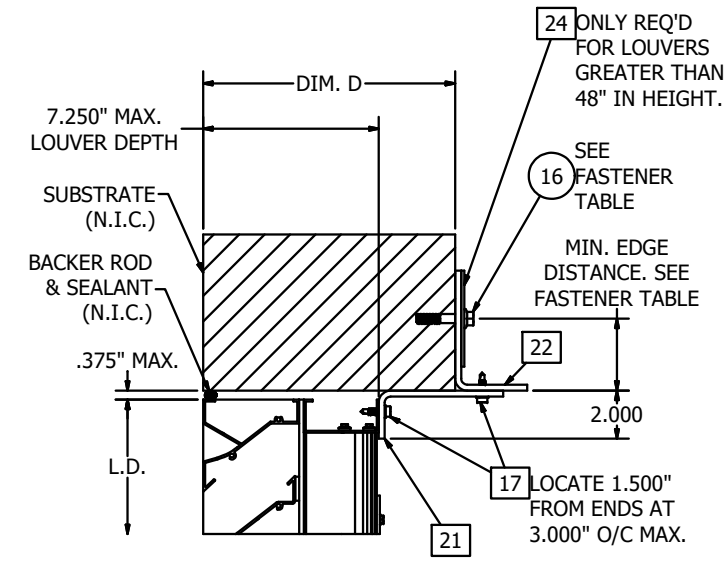

DETAIL 8
DOUBLE ANGLE INSTALLED AT HEAD

SUBSTRATE FASTENER TABLE (N.I.C.) / HZ700MD 130 PSF / RETAINING ZEE & DOUBLE ANGLE INSTALL

SUBSTRATE TYPE	MIN. SUBSTRATE REQUIREMENTS	FASTENER TYPE	MAX. C/C SPACING AT HEAD / SILL	MIN. EMBEDMENT	MIN. EDGE DISTANCE
WOOD	3" THICK, 0.42 SPECIFIC GRAVITY	3/8-16 BOLT W/NUT, MIN A307 GRADE A	12"	3 THREADS BEYOND NUT	1-1/2"
		3/8" DIA. LAG SCREW, 2 1/2" LONG, MIN. A307 GRADE A	12"	2-1/4"	1-1/2"
STEEL	18 GA, 45 KSI TENSILE STRENGTH, 33KSI YIELD STRENGTH	1/4-20 BOLT W/NUT & WASHER MIN A307 GRADE A	6"	3 THREADS BEYOND NUT	1/2"
	12 GA, 45 KSI TENSILE STRENGTH, 33KSI YIELD STRENGTH	1/4-20 SELF-DRILLING SCREW W/ WASHER CARBON STEEL	6"	3 THREADS BEYOND SUBSTR. THICKNESS	1/2"
ALUMINUM	0.125" THICK, 20 KSI TENSILE STRENGTH, 15 KSI YIELD STRENGTH	1/4-20 BOLT W/NUT & WASHER MIN A307 GRADE A	12"	3 THREADS BEYOND NUT	1/2"
	0.1875" THICK, 20 KSI TENSILE STRENGTH, 15 KSI YIELD STRENGTH	1/4-20 SELF-DRILLING SCREW W/ WASHER CARBON STEEL	3"	3 THREADS BEYOND SUBSTR. THICKNESS	1/2"
CONCRETE	2500 PSI COMPRESSIVE STRENGTH	3/8" DIA. SIMPSON STRONG-TIE TITEN HD SCREW ANCHOR CARBON STEEL	12"	3-1/4"	3"
		3/8" DIA. DEWALT SCREW BOLT + SCREW ANCHOR CARBON STEEL	6"	3-1/4"	4"
		3/8" DIA. HILTI KWIK HUS-EZ SCREW ANCHOR CARBON STEEL	12"	3 1/4"	2 1/2"
		1/4" DIA. ELCO AGGRE-GATOR W/ WASHER 300 SERIES SS	3"	1-3/8"	1-1/2"
GROUT FILLED CMU	ASTM C-90 BLOCK, 1500 PSI GROUT COMPRESSIVE STRENGTH	3/8" DIA. SIMPSON STRONG-TIE TITEN HD SCREW ANCHOR CARBON STEEL	6"	2 -3/4"	4"
		3/8" DIA. DEWALT SCREW BOLT + SCREW ANCHOR CARBON STEEL	12"	3 1/4"	2"
		3/8" DIA. HILTI KWIK HUS-EZ SCREW ANCHOR CARBON STEEL	12"	3-1/4"	4"
		1/4" DIA. ELCO AGGRE-GATOR W/ WASHER 300 SERIES SS	6"	2"	2"

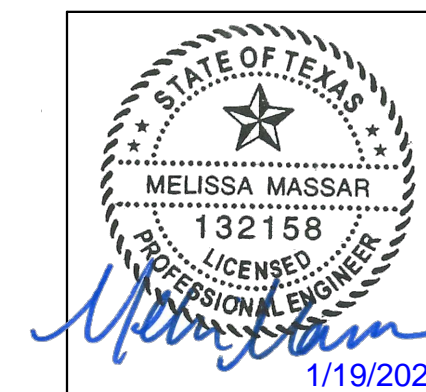

MELISSA MASSAR, P.E.
NO. 132158

AUTHOR	DKF	9/24/2020	 3900 Doctor Greaves Rd, Grandview, MO 64030 PROPRIETARY AND CONFIDENTIAL
CHECKED	E-R	9/27/2020	
APPROVED	TCB	10/28/2020	
APPROVED	MMM	10/30/2020	
MATERIAL	EXTRUDED ALUMINUM	TITLE	LOUVER INSTALL / RETAINING ZEE & DOUBLE ANGLE
SIZE	B	DWG NO	60-022580-00B
SCALE	NONE	INVENTOR	SHEET 8 OF 10

REAR LOUVER FRAME PROFILES

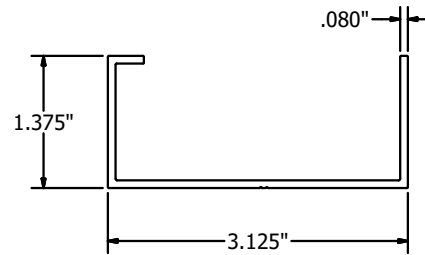

HEAD FRAME ITEM-1
N.T.S.

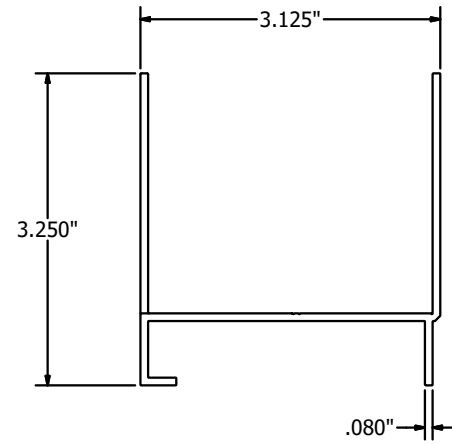

SILL FRAME ITEM-2
N.T.S.

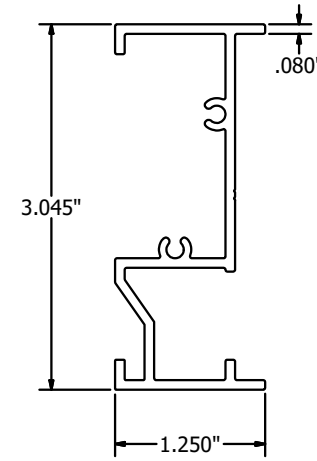

JAMB FRAME ITEM-3
N.T.S.

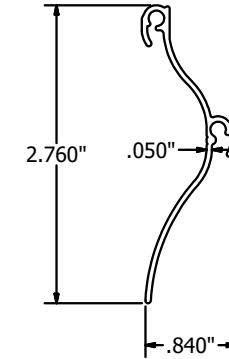

BLADE ITEM-4
N.T.S.

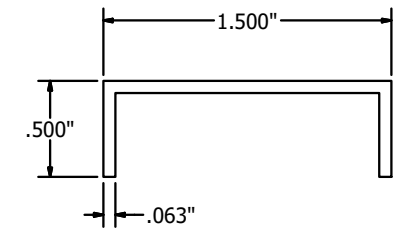

SECTION

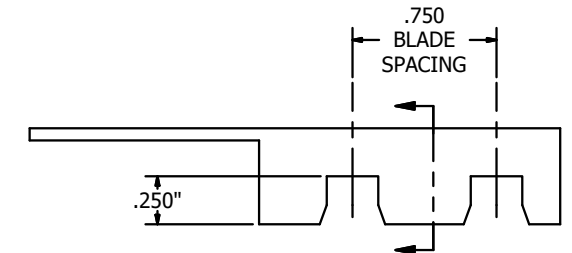

H.H.B.S. ITEM-5
N.T.S.

FRONT LOUVER FRAME PROFILES

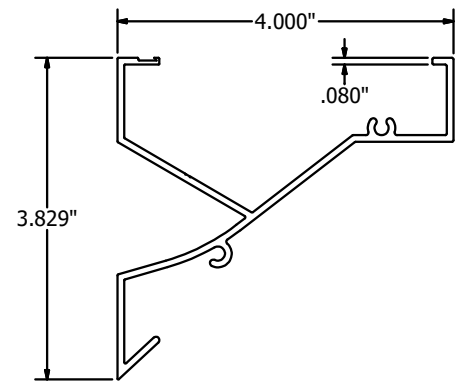

HEAD FRAME ITEM-7
N.T.S.

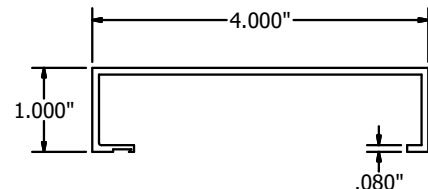

SILL FRAME ITEM-8
N.T.S.

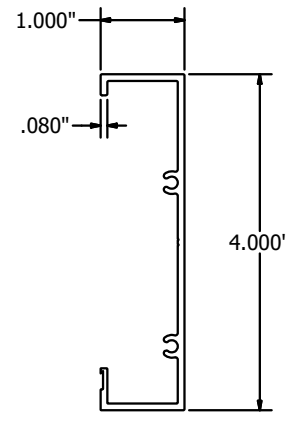

JAMB FRAME ITEM-9
N.T.S.

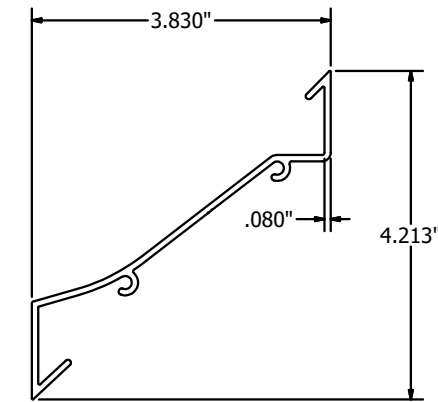

BLADE ITEM-10
N.T.S.

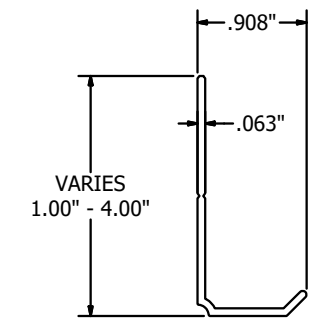

WATERSTOP ITEM-11
N.T.S.

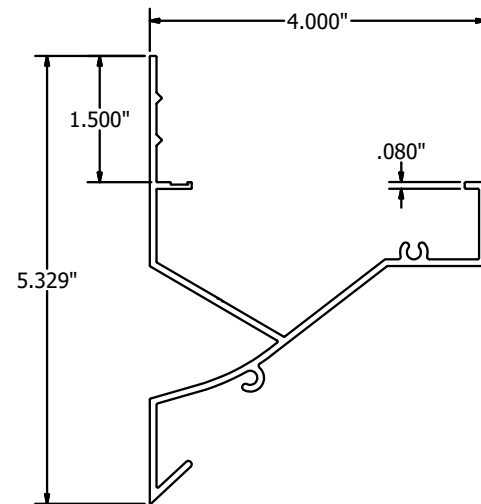

FLANGED HEAD FRAME ITEM-12
N.T.S.

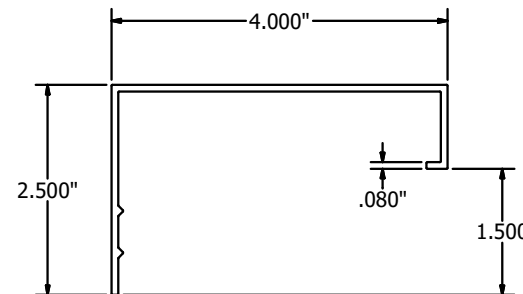

FLANGED SILL FRAME ITEM-13
N.T.S.

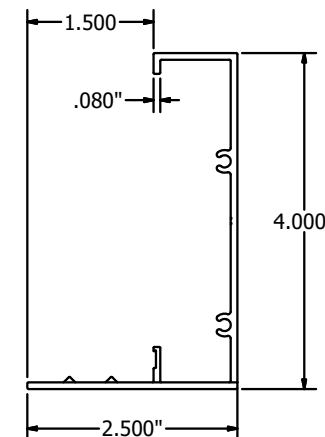

FLANGED JAMB FRAME ITEM-14
N.T.S.



MELISSA MASSAR, P.E.
NO. 132158

AUTHOR	DKF	9/24/2020	 3900 Doctor Greaves Rd, Grandview, MO 64030 PROPRIETARY AND CONFIDENTIAL
CHECKED	E-R	9/27/2020	
APPROVED	TCB	10/28/2020	
APPROVED	MMM	10/30/2020	
MATERIAL	EXTRUDED ALUMINUM	TITLE	LOUVER FRAME PROFILES
SIZE	B	DWG NO	60-022580-00B
SCALE	NONE	INVENTOR	SHEET 9 OF 10

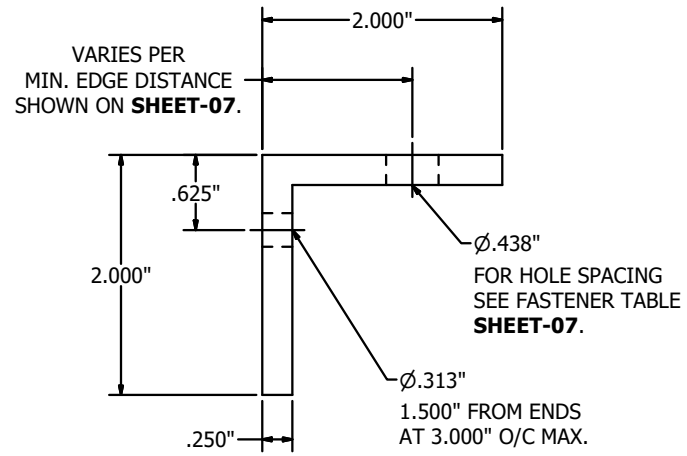

RETAINING ANGLE ITEM-15
N.T.S.

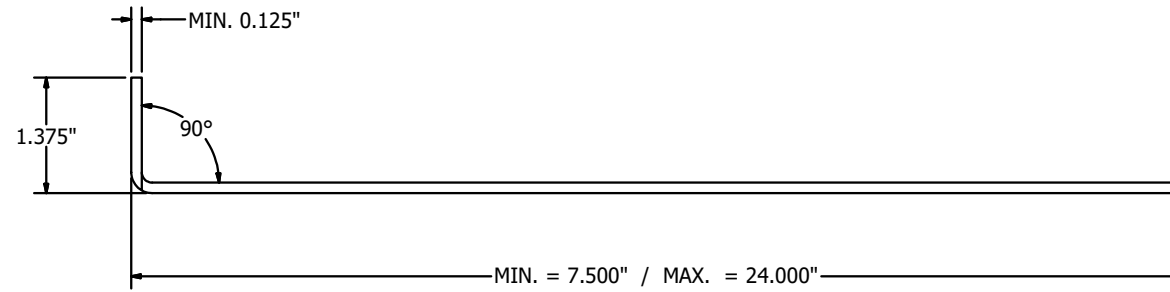

UNIVERSAL SLEEVE ITEM-18
N.T.S.

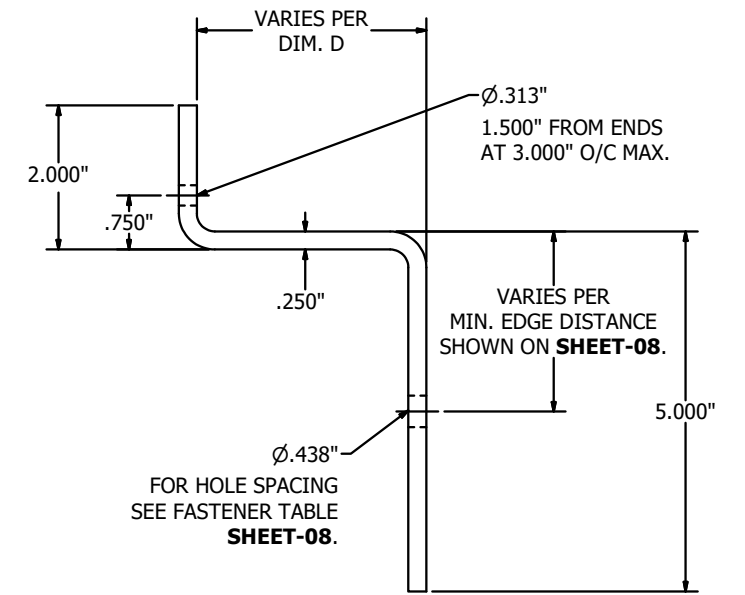

RETAINING ZEE ITEM-20
N.T.S.

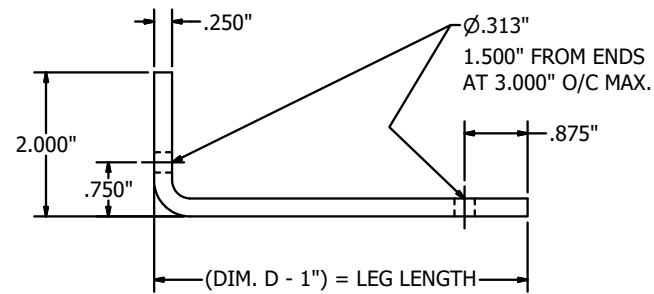

RETAINING ANGLE ITEM-21
N.T.S.

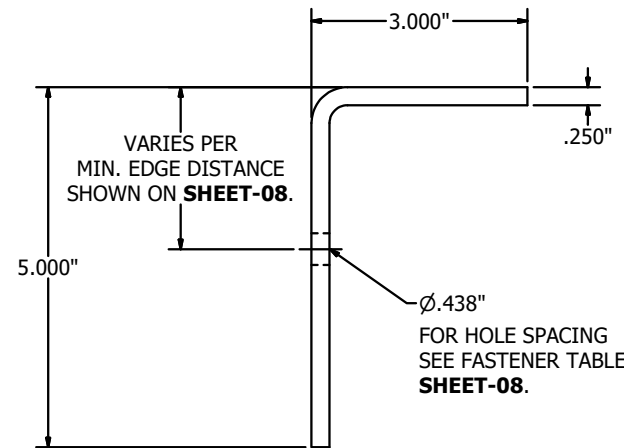

RETAINING ANGLE ITEM-22
N.T.S.

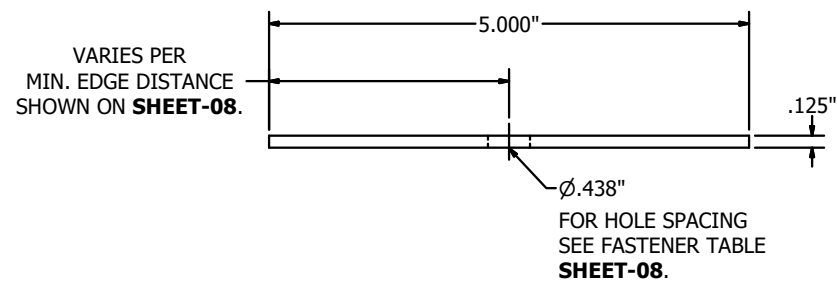

STIFFENER PLATE ITEM-23
N.T.S.

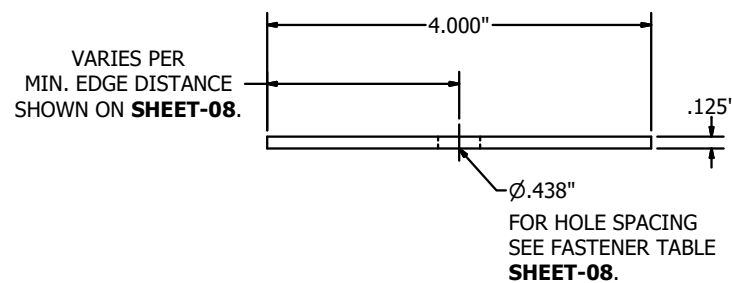

STIFFENER PLATE ITEM-24
N.T.S.



MELISSA MASSAR, P.E.
NO. 132158

AUTHOR	DKF	9/24/2020	 3900 Doctor Greaves Rd, Grandview, MO 64030 PROPRIETARY AND CONFIDENTIAL
CHECKED	E-R	9/27/2020	
APPROVED	TCB	10/28/2020	
APPROVED	MMM	10/30/2020	
MATERIAL	EXTRUDED ALUMINUM	TITLE	INSTALL PARTS PROFILES
SIZE	B	DWG NO	60-022580-00B
ECN		SCALE	NONE
		INVENTOR	SHEET 10 OF 10