

## Product Evaluation

FR02 | 0621

Engineering Services Program

The following product has been evaluated for compliance with the wind loads specified in the International Residential Code (IRC) and the International Building Code (IBC).

This product evaluation is not an endorsement of this product or a recommendation that this product be used. The Texas Department of Insurance has not authorized the use of any information contained in the product evaluation for advertising, or other commercial or promotional purpose.

This product evaluation is intended for use by those individuals who are following the design wind load criteria in Chapter 3 of the IRC and Section 1609 of the IBC. The design loads determined for the building or structure shall not exceed the design load rating specified for the products shown in the limitations section of this product evaluation. This product evaluation does not relieve a Texas licensed engineer of his responsibilities as outlined in the Texas Insurance Code, the Texas Administrative Code, and the Texas Engineering Practice Act.

For more information, contact TDI Engineering Services Program at (800) 248-6032.

**Evaluation ID:** FR-02

**Effective Date:** June 1, 2021

**Re-evaluation Date:** June 2025

**Product Name:** R-Control Structural Insulated Panels (SIPs)

**Manufacturer:** Thermafoam R-Control, LLC  
203 South Redmond Road  
Jacksonville, AR 72076  
(501) 945-1114  
[www.thermafoamrcontrol.com](http://www.thermafoamrcontrol.com)

will be acceptable as an alternative residential construction method in designated catastrophe areas along the Texas Gulf Coast when constructed in accordance with this product evaluation.

### General Description:

R-Control Structural Insulated Panels (SIPs) are factory-built structural insulated panels that are used as structurally insulated wall, roof, and floor panels in buildings. The SIPs are fabricated to fit each specific design situation and are subsequently assembled on the job site to form the structural shell. The SIPs consist of oriented strand board (OSB) facings with an expanded polystyrene (EPS) core. The OSB is bonded to the EPS core with structural grade adhesive. The SIPs may be used as loadbearing and non-loadbearing wall and roof components as well as floor components. The SIP thickness is available from 4-1/2" to 12-1/4". The SIPs are available in widths from 4 feet to 8 feet and in lengths from 8 feet to 24 feet.

The top and bottom plates of the SIPs are dimension lumber that is sized to match the EPS core thickness of the SIPs. The dimension lumber top and bottom plates are secured to the OSB face panels with Low VOC Do-All-Ply® sealant and fasteners.

R-Control SIPs are connected to each other at the panel edges using splines which may consist of dimension lumber, engineered wood products, or pre-fabricated I-beams which have been evaluated by AFM for use with the SIPs. The SIPs are connected together with the splines using fasteners and Low VOC DO-All-Ply® sealant.

**Product Identification:** Each R-Control SIP shall bear the manufacturer's name and the label of the inspection agency, PFS Corporation.

**Installation:**

**General:** Structures built using the R-Control SIPs must be designed and inspected by a Texas licensed professional engineer that is appointed by TDI. Requirements for the design of the SIPs must be based on the tables and details specified in this evaluation report and the manufacturer's installation requirements. The tables presented in this evaluation report are for the design of the SIPs for walls, roof, and floors. The design of chords, struts, and connections (such as the attachment of diaphragms to chords and struts, the attachment of the SIPs to the foundation, and the hardware required to resist uplift, shear, and the overturning of the shear wall segments) must be designed separately. Design drawings must include instructions for the connection and installation of the panels. The design drawings must be sealed and dated by the design engineer. The design drawings must reference the appropriate edition of the wind load standard (ASCE 7) used based on the current building specifications adopted by TDI. The basic wind speed and the exposure category used for the design must also be referenced.

**Design loads:** Design wind loads for the SIPs must be determined using the wind load requirements for the structure as specified in the building specifications adopted by TDI. All loads on the SIPs must not exceed the allowable loads specified in load design charts.

**Load Design Charts:** Allowable axial, transverse, racking, header, and diaphragm loads for the SIPs must be as specified in Tables 1-9 of this evaluation report and as specified in the R-Control Load Design Charts for SIPs (Structural Insulated Panels), dated June 2012. NOTE: The requirements specified in the tables in this evaluation report must govern if there are any conflicts between the manufacturer's Load Design Charts and the tables and figures in this evaluation report.

**Foundation:** The foundation is considered to be part of the structure and must be considered part of the design for the structure. If the foundation is not designed by the engineer responsible for the design of the SIP system, then the design plans must indicate such. As a minimum, the design plans must indicate how the SIP system is to be anchored to the foundation. If the foundation is included as part of the design, then the design plans must include all details and specifications related to the design of the foundation to resist the specified wind loads and must indicate how the structure is to be anchored to the foundation.

**Roof Coverings:** The design plans must indicate the requirements for the roof coverings. The roof coverings must comply with the building specifications adopted by TDI. For roof coverings other than asphalt shingles, the design plans must specify the design pressure requirements for the roof covering. The roof covering must be installed as required to resist wind pressure.

**Exterior wall coverings:** Exterior wall coverings must be installed as required to resist wind pressure. Products must comply with the building specifications adopted by the TDI. The design plans must specify the design pressure requirements for the exterior wall coverings.

**Windows, doors, garage doors, and skylights:** Products must be installed as specified in evaluation reports to resist wind pressure. Products must comply with the building specifications adopted by TDI. The design plans must specify the design pressure requirements for the products. The design plans must indicate if the products are required to be windborne debris resistant. Windborne debris resistant products must be installed as specified in evaluation reports to resist wind pressure and windborne debris.

**Shutters:** The design plans must indicate if shutters are required. Products must be installed as specified in evaluation reports or the building specifications adopted by TDI as required to resist wind pressure and windborne debris. Products must comply with the building specifications adopted by TDI. The design plans must specify the design pressures requirements for the shutters.

**Note:** A set of sealed plans, manufacturer's installation instructions, R-Control Load Design Charts for SIPs (Structural Insulated Panels), dated June 2012, and this product evaluation report must be available to the inspector at the job site at all times. All fasteners must be corrosion resistant as specified in the IRC, the IBC, and the Texas Revisions.

#### Wall – Unity Equation

The equation shown below is to determine design suitability. The equation takes into account the ultimate load for a panel subjected to both axial load and transverse (bending) load conditions.

$$\frac{\textit{Design Axial Load}}{\textit{Allowable Axial Load}} + \frac{\textit{Design Transverse Load}}{\textit{Allowable Transverse Load}} \leq 1$$

Note: Refer to Table 1 for Wall Axial Loading.

Refer to Table 3 for Wall Transverse Loading.

Table 1  
Wall – Uniform Axial Loads  
(See Detail SIP-101c)

<b>R-CONTROL STRUCTURAL INSULATED PANEL</b>						
<b>SIP THICKNESS</b>	<b>SIP HEIGHT (FEET)</b>					
	<b>8</b>	<b>8 WAB<sup>1</sup></b>	<b>10</b>	<b>12</b>	<b>14</b>	<b>16</b>
4-1/2"	2750	2300	2500	2000		
6-1/2"	4000	2400	3500	3000	2750	2500
8-1/4"	4000	2400	3500	3000	2750	2500
10-1/4"	4000	2400	3500	3000	2750	2500
12-1/4"	4000	2400	3500	3000	2750	2500

<sup>1</sup>WAB = SIPS installed with the strong axis of the OSB facings perpendicular to SIP height.

**GENERAL NOTES:**

Chart Values are pounds per square foot.

Loads limited by deflection or ultimate failure load divided by a factor of safety of three.

Table 2  
Walls – Shear Loading – PLF  
(See Detail SIP-102, SIP-102g, SIP-102m, or SIP-102k)

<b>R-CONTROL STRUCTURAL INSULATED PANEL</b>			
<b>SPLINE TYPE</b>	<b>CONNECTIONS</b>		<b>SHEAR STRENGTH</b>
	<b>NAIL TYPE</b>	<b>NAIL SPACING</b>	
Surface or Block	8d Box (2-1/2" x 0.113")	6" o.c.	335
1x Lumber Block	8d Cooler (2-3/8" x 0.113")	Two staggered rows 4" o.c.	540
4x Lumber	8d Cooler (2-3/8" x 0.113")	Two staggered rows 4" o.c.	540
4x Lumber	8d Cooler (2-3/8" x 0.113")	Two staggered rows 3" o.c.	720
4x Lumber	8d Cooler (2-3/8" x 0.113")	Two staggered rows 2" o.c.	920

**GENERAL NOTES:**

Chart values are pounds per lineal foot.

Chart values are applicable to any thickness SIP.

Loads limited by deflection or ultimate failure load divided by a factor of safety of three.

Required connections must be made on both sides of spline joint, bottom plate, top plate, and each side of the SIP.

Top plate joints must be staggered a minimum of one foot from spline joints.

Plates, chords, hold-downs, and connections to other structural elements must be designed by a Texas licensed Professional Engineer in accordance with accepted engineering practice.

Table 3  
Wall-Transverse Loads- PSF  
(See Detail SIP-101c)

R-CONTROL STRUCTURAL INSULATED PANEL							
SIP THICKNESS	DEFLECTION LIMIT	SIP HEIGHT (FEET)					
		8	8 WAB <sup>1</sup>	10	12	14	16
4-1/2"	L/360	30	30	22	17		
	L/240	46	40	33	25		
	L/180	56	40	45	34		
6-1/2"	L/360	48	40	36	28	22	18
	L/240	56	40	45	38	32	27
	L/180	56	40	45	38	32	28
8-1/4"	L/360	56	40	45	38	31	25
	L/240	56	40	45	38	32	28
	L/180	56	40	45	38	32	28
10-1/4"	L/360	56	40	45	38	32	28
	L/240	56	40	45	38	32	28
	L/180	56	40	45	38	32	28
12-1/4"	L/360	56	40	45	38	32	28
	L/240	56	40	45	38	32	28
	L/180	56	40	45	38	32	28

<sup>1</sup> WAB= SIPS installed with the strong axis of the OSB facings perpendicular to SIP height.

**GENERAL NOTES:**

Chart values are pounds per square foot.

Chart values are applicable to any spline connection.

Surface, block or lumber block spline connected to SIP facing with 8d box (0.113) at 6" o.c.

Values are for total load (Dead Load + Live Load)

Loads limited by deflection or ultimate failure load divided by a factor of safety of three.

Table 4  
Roof/Floor-Transverse Loads- PSF  
(See Details SIP-102, SIP-102g, or SIP-102m)

<b>R-CONTROL STRUCTURAL INSULATED PANEL</b>						
<b>SIP THICKNESS</b>	<b>DEFLECTION LIMIT</b>	<b>SIP HEIGHT (FEET)</b>				
		<b>4</b>	<b>6</b>	<b>8<sup>1</sup></b>	<b>10</b>	<b>12</b>
4-1/2"	L/360	69	44	30	22	
	L/240	104	35	46	33	
	L/180	127	85	61	45	
6-1/2"	L/360	105	67	48	36	
	L/240	131	88	66	53	
	L/180	131	88	66	53	
8-1/4"	L/360	135	88	63	48	38
	L/240	135	90	68	54	45
	L/180	135	90	68	54	45
10-1/4"	L/360	140	92	69	55	46
	L/240	140	92	69	55	46
	L/180	140	92	69	55	46
12-1/4"	L/360	140	92	69	55	46
	L/240	140	92	69	55	46
	L/180	140	92	69	55	46

<sup>1</sup> values for 8 ft. span are applicable to SIPS installed with the strong axis of the OSB facings parallel or perpendicular to SIP span.

**GENERAL NOTES:**

Chart values are pounds per square foot.

Surface, block or lumber block spline connected to SIP facing with 8d box (0.113) at 6" o.c.

Continuous support with a minimum bearing of 1-1/2" at each end required.

Chart is based on uniform loads.

Loads limited by deflection or ultimate failure load divided by a factor of safety of three.

Floors must have a minimum 7/16" thick OSB or equivalent overlay.

For sloped SIPS, the loading conditions and sip capacities should be reviewed based upon the inclined SIP length. Refer to R-Control SIP technical bulletin SIP No. 2042.

Values are for total load (Dead Load + Live Load)

Deflection based upon  $K_{cr}=1.0$  for long term deflection under sustained load (Creep), additional deflection must be evaluated.

Table 5  
Roof/Floor – Transverse Loads – PSF  
(See 2x Spline Details SIP-102d and SIP-108)

R-CONTROL STRUCTURAL INSULATED PANEL									
SIP THICKNESS	DEFLECTION LIMIT	SIP SPAN (FEET)							
		10	12	14	16	18	20	22	24
6-1/2"	L/360	53	40	30	24	19	15		
	L/240	79	59	45	35	28	22		
	L/180	105	79	60	47	37	30		
8-1/4"	L/360	89	65	48	37	28	22		
	L/240	109	91	72	55	42	33		
	L/180	109	91	78	68	57	44		
10-1/4"	L/360	150	111	84	65	51	41	33	27
	L/240	174	145	124	98	77	61	49	40
	L/180	174	145	124	109	97	82	66	54
12-1/4"	L/360	177	148	115	89	70	56	45	37
	L/240	177	148	127	111	99	84	68	55
	L/180	177	148	127	111	99	89	81	74

**GENERAL NOTES:**

Chart Values are pounds per square foot.

Double 2x spline must be continuous, spaced 4' o.c., and connected to SIP facing with 8d box (0,113) nails at 6" o.c.

Continuous support with a minimum double 2x spline bearing of 1-1/2" at each end required.

Chart is based on uniform loads.

Loads limited by deflection or ultimate failure load divided by a factor of safety of three.

Floors must have a minimum 7/16" thick OSB or equivalent overlay.

For spans greater than 22' and for all 12-1/4" SIPs, double 2x spline is required to be #2 Douglas Fir or better.

For sloped SIPs, the loading conditions and SIP capacities should be reviewed based upon the inclined SIP length. Refer to R-CONTROL SIP Technical Bulletin No. 2042.

Values are for Total Load (Dead Load+Live Load).

Deflection based upon  $K_{cr}=1.0$  for long term deflection under sustained load (Creep), additional deflection must be evaluated.



Table 6  
Roof/Floor – Transverse Loads – PSF  
(See I-Beam Spline Details SIP-102b and SIP-108a)

<b>R-CONTROL STRUCTURAL INSULATED PANEL</b>									
<b>SIP THICKNESS</b>	<b>DEFLECTION LIMIT</b>	<b>SIP SPAN (FEET)</b>							
		<b>10</b>	<b>12</b>	<b>14</b>	<b>16</b>	<b>18</b>	<b>20</b>	<b>22</b>	<b>24</b>
10-1/4"	L/360	118	98	73	55	42	33	26	21
	L/240	118	98	84	74	63	49	39	31
	L/180	118	98	84	74	65	59	49	41
12-1/4"	L/360	131	109	97	69	55	45	37	30
	L/240	131	109	93	82	72	65	55	46
	L/180	131	109	93	82	72	65	57	48

**GENERAL NOTES:**

Chart Values are pounds per square foot.

I-Beam spline must be continuous, spaced 4' o.c., and connected to SIP facing with 8d box (0.113) nails at 6" o.c.

Continuous support with a minimum I-Beam spline bearing of 1-1/2" at each end required.

Chart is based on uniform loads.

Loads limited by deflection or ultimate failure load divided by a factor of safety of three.

Floors must have a minimum 7/16" thick OSB or equivalent overlay.

For sloped SIPs, the loading conditions and SIP capacities should be reviewed based upon the inclined SIP length. Refer to R-CONTROL SIP Technical Bulletin No. 2042.

Values are for Total Load (Dead Load+Live Load).

Deflection based upon  $K_{cr}=1.0$  for long term deflection under sustained load (Creep), additional deflection must be evaluated.

Table 7  
Roof/Floor-Transverse Loads- PSF  
(LVL Spline Detail SIP-102a)

R-CONTROL STRUCTURAL INSULATED PANEL							
SIP THICKNESS	DEFLECTION LIMIT	SIP SPAN (FEET)					
		10	12	14	16	18	20
		R-CONTROL LVL SPLINE WIDTH					
		1-3/4"			2-1/2"		
8-1/4"	L/360	81	63	49	38	30	24
	L/240	81	68	58	51	45	31
	L/180	81	68	58	51	45	40

**GENERAL NOTES:**

Chart Values are pounds per square foot.

LVL spline must be continuous, spaced 4' o.c., and connected to SIP facing with 8d box (0.113) nails at 6" o.c.

Continuous support with a minimum LVL spline bearing of 1-1/2" at each end required.

Chart is based on uniform loads.

Loads limited by deflection or ultimate failure load divided by a factor of safety of three.

Floors must have a minimum 7/16" thick OSB or equivalent overlay.

For sloped SIPs, the loading conditions and SIP capacities should be reviewed based upon the inclined SIP length. Refer to R-CONTROL SIP Technical Bulletin No. 2042.

Values are for Total Load (Dead Load+Live Load).

Deflection based upon  $K_{cr}=1.0$  for long term deflection under sustained load (Creep), additional deflection must be evaluated.

Table 8  
 Wall-Header Loads – PSF  
 (See Details SIP-112 through SIP-114)

<b>R-CONTROL STRUCTURAL INSULATED PANEL</b>				
<b>HEADER DEPTH</b>	<b>DEFLECTION LIMIT</b>	<b>HEADER SPAN (FEET)</b>		
		<b>4</b>	<b>6</b>	<b>8</b>
12"	L/480	524	319	218
	L/360	703	374	248
	L/240	708	374	248
18"	L/480	762	466	351
	L/360	773	466	351
	L/240	773	466	351
24"	L/480	837	557	455
	L/360	837	557	455
	L/240	837	557	455

**GENERAL NOTES:**

Chart values are pounds per lineal foot.

Loads limited by deflection or ultimate failure load divided by a factor of safety of three.

Posts supporting header, when required, must be designed by Texas licensed Professional Engineer in accordance with accepted engineering practice.

Table 9  
Roof/Floor – Diaphragm Loads – PLF  
(See Details SIP-139a, SIP-140 and SIP-141)

<b>R-CONTROL STRUCTURAL INSULATED PANEL</b>				
<b>FASTENER SPACING</b>				
<b>BOUNDARIES<sup>1</sup></b>		<b>SPLINES<sup>2</sup></b>	<b>SIPS TO SUPPORT PARALLEL TO SHEAR</b>	<b>ALLOWABLE STRENGTH (PLF)</b>
<b>R-CONTROL SCREWS<sup>3</sup></b>	<b>8D BOX NAILS</b>	<b>8D BOX NAILS</b>	<b>R-CONTROL SCREWS<sup>3</sup></b>	
6"	3" @ top and bottom	3" two rows each side of joint and staggered	12"	500
4"	3" @ top and bottom	3" two rows each side of joint and staggered	12"	750
3"	3" @ top and bottom	3" two rows each side of joint and staggered	12"	850

<sup>1</sup> Diaphragm boundary elements must consist of full-depth, solid sawn lumber, 2-inch minimum nominal width, minimum specific gravity of 0.50, inserted in SIP core, continuous across panel joints. Panel edges parallel to applied shear shall be reinforced with solid sawn lumber, 4-inch minimum nominal width, and minimum specific gravity of 0.50.

<sup>2</sup> Nails connect SIP facings at joints to OSB surface splines located under top face at all panel edges, at the tabulated spacing.

<sup>3</sup> Diaphragm secured to support members with R-CONTROL screws at the tabulated spacing and a minimum 1-5/8" penetration into the receiving member.

**GENERAL NOTES:**

Chart values are pounds per lineal foot.

Surface, block, or lumber block spline.

Loads limited by ultimate failure load divided by a factor of safety of three.

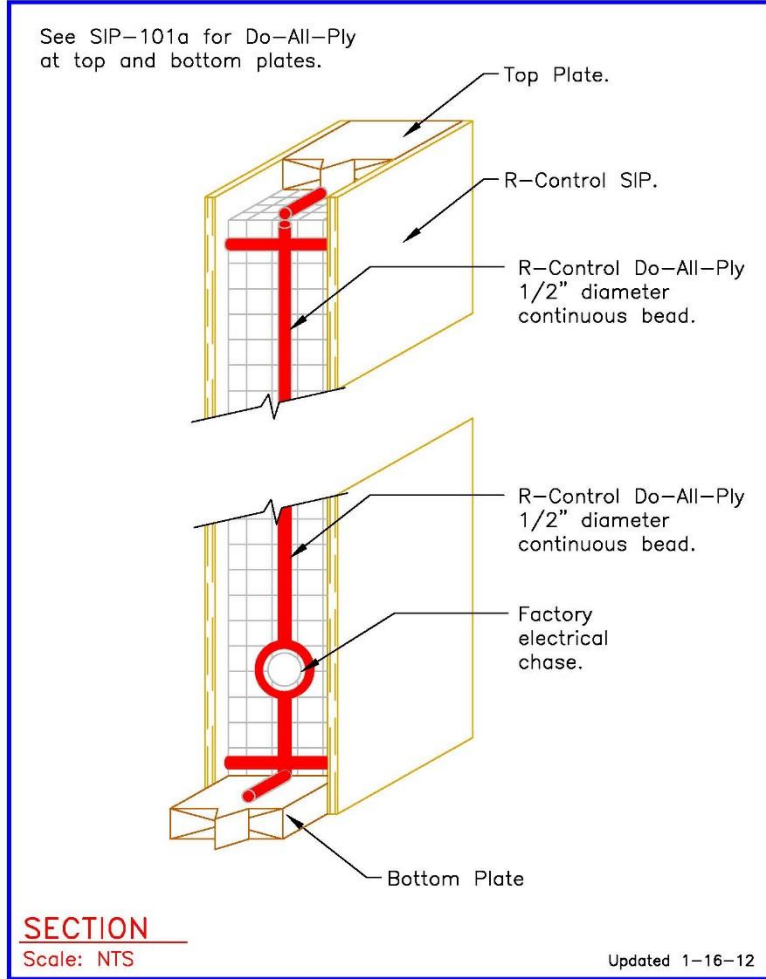

<b>R-Control® SIP</b>	
TITLE: Do-All-Ply® Application	NO. SIP-101b

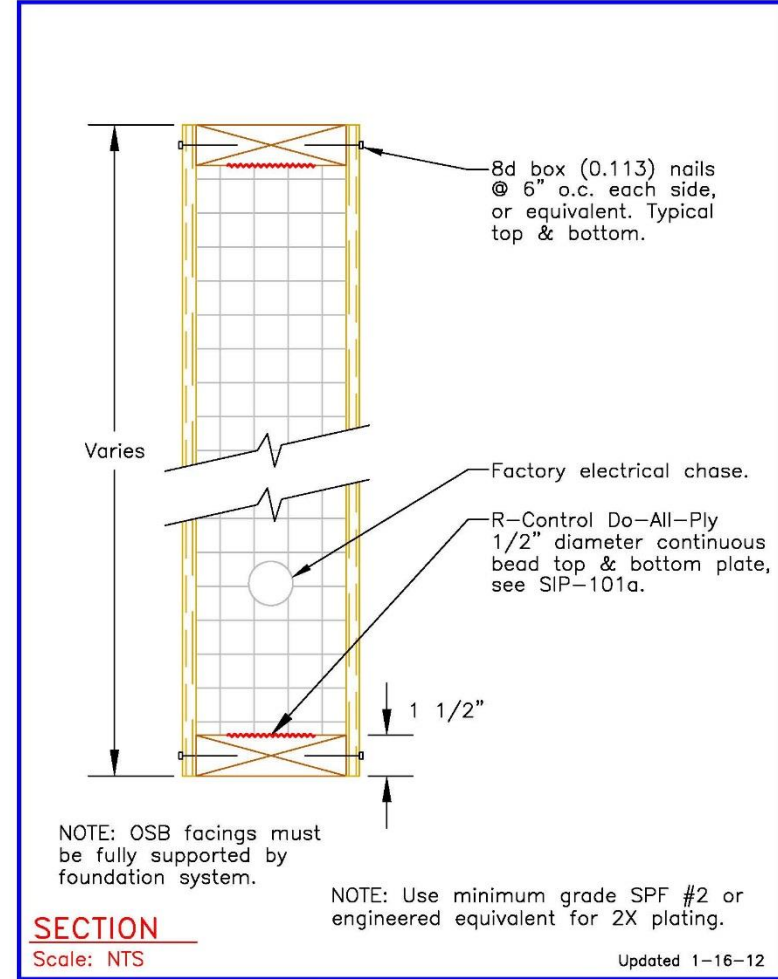

<b>R-Control® SIP</b>	
TITLE: Plate Connections	NO. SIP-101c

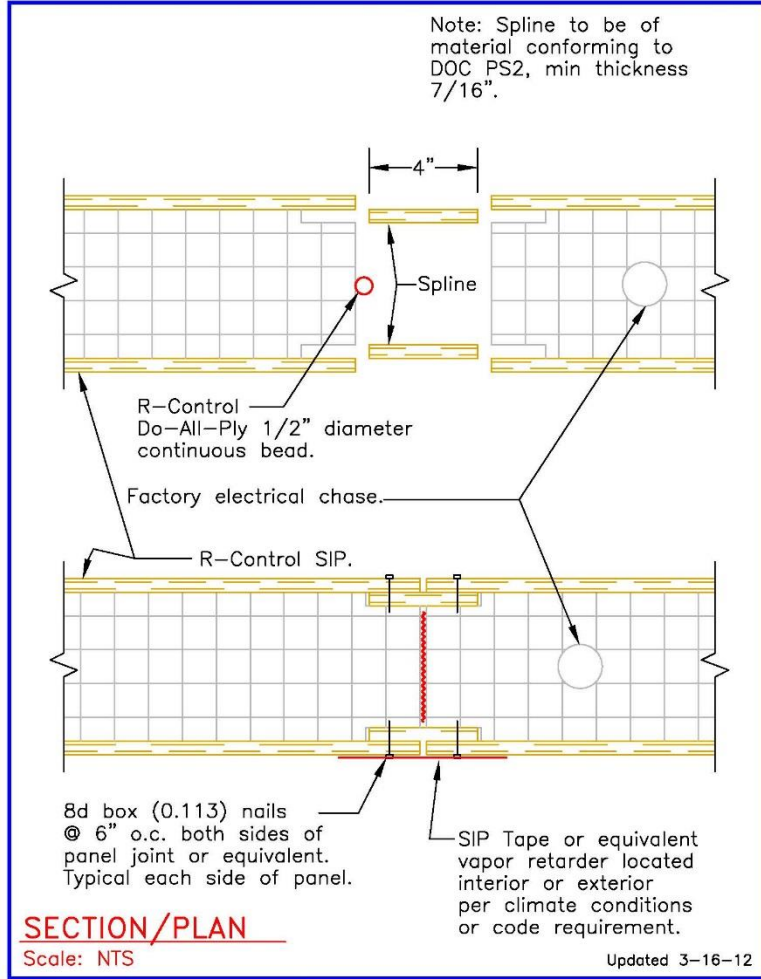

<b>R-Control® SIP</b>	
TITLE: Spline Connection Surface Spline	NO. SIP-102

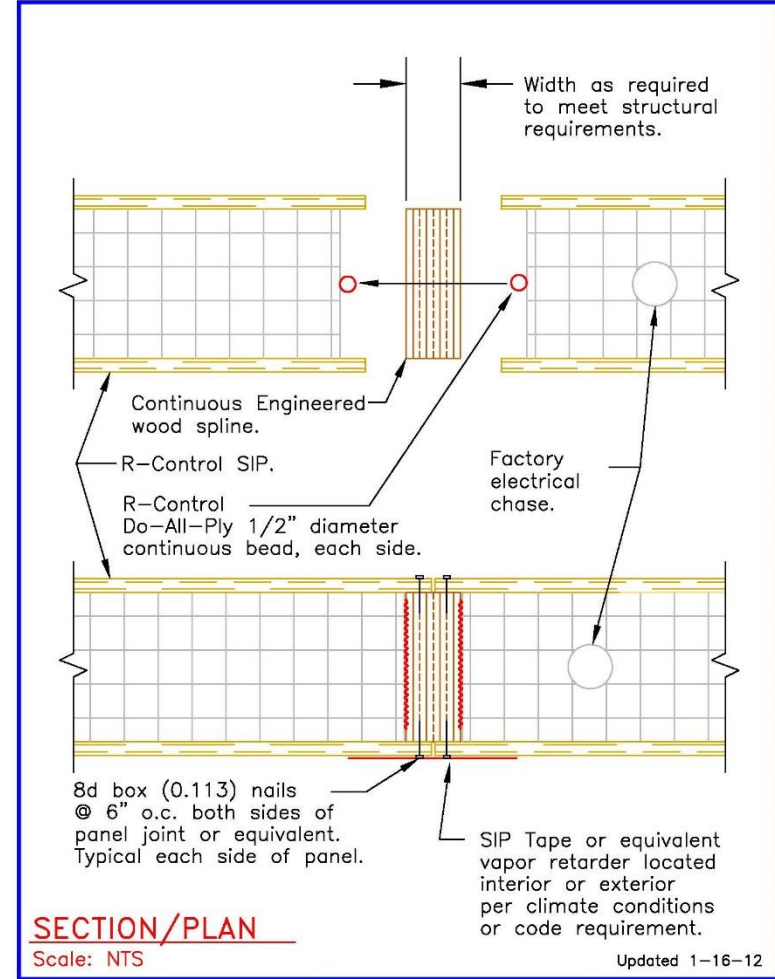

<b>R-Control® SIP</b>	
TITLE: Spline Connection Engineered Wood	NO. SIP-102a

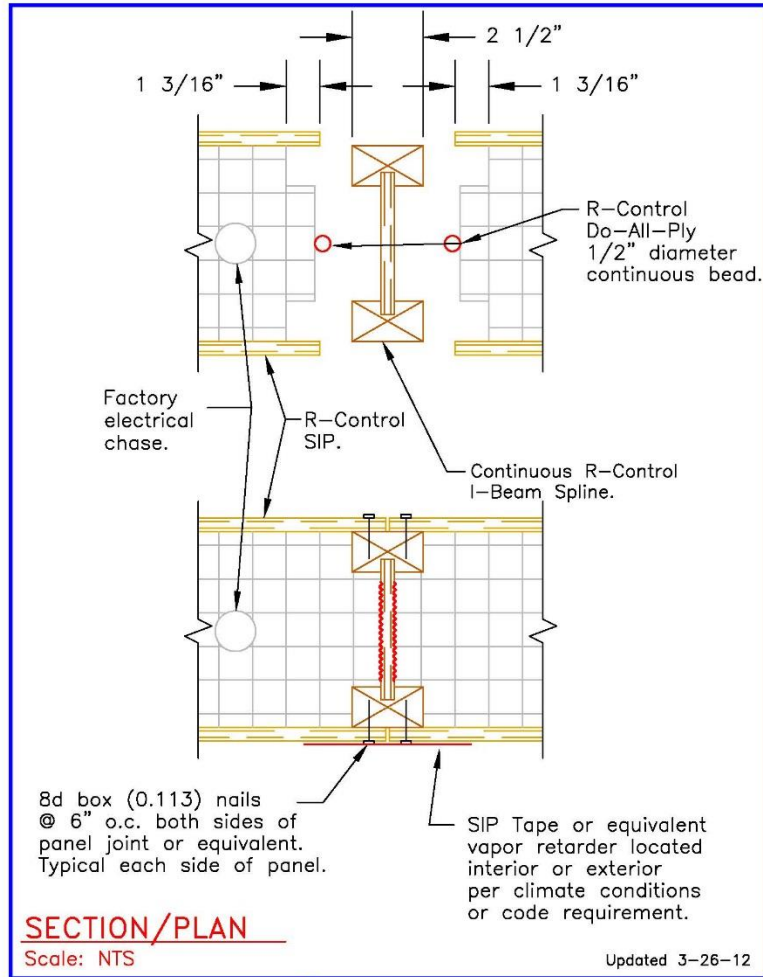

<b>R-Control® SIP</b>	
TITLE: Spline Connection I-Beam Spline	NO. SIP-102b

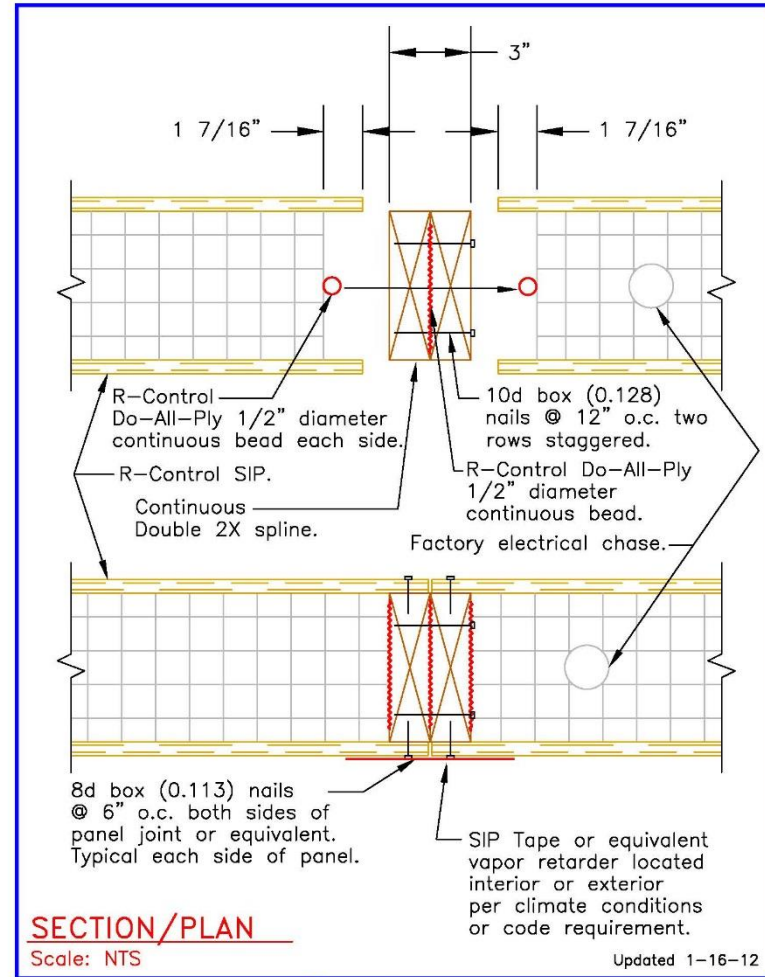

<b>R-Control® SIP</b>	
TITLE: Spline Connection Double 2X	NO. SIP-102d

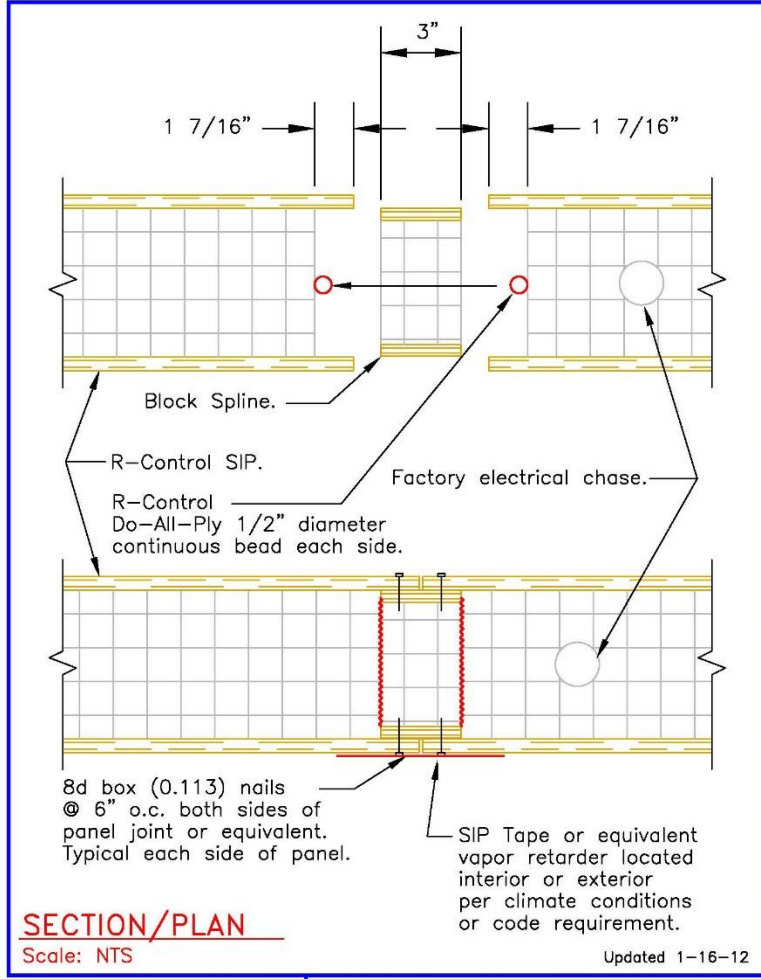

<b>R-Control® SIP</b>	
TITLE: Spline Connection Block Spline	NO. SIP-102g

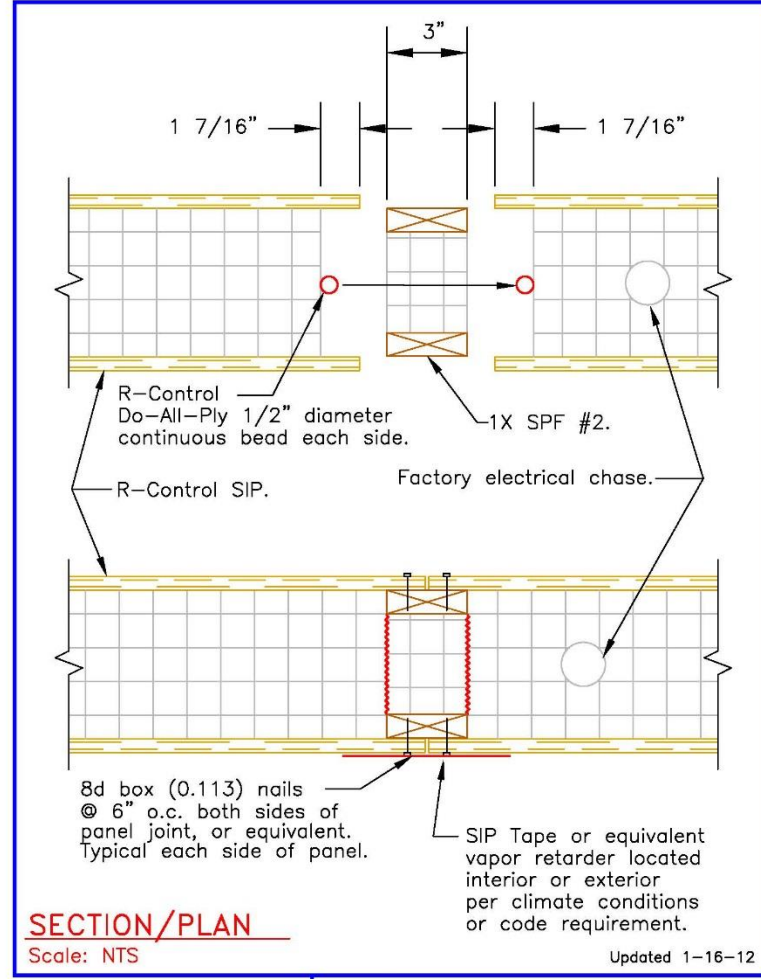

<b>R-Control® SIP</b>	
TITLE: Spline Connection 1X Lumber Block	NO. SIP-102m



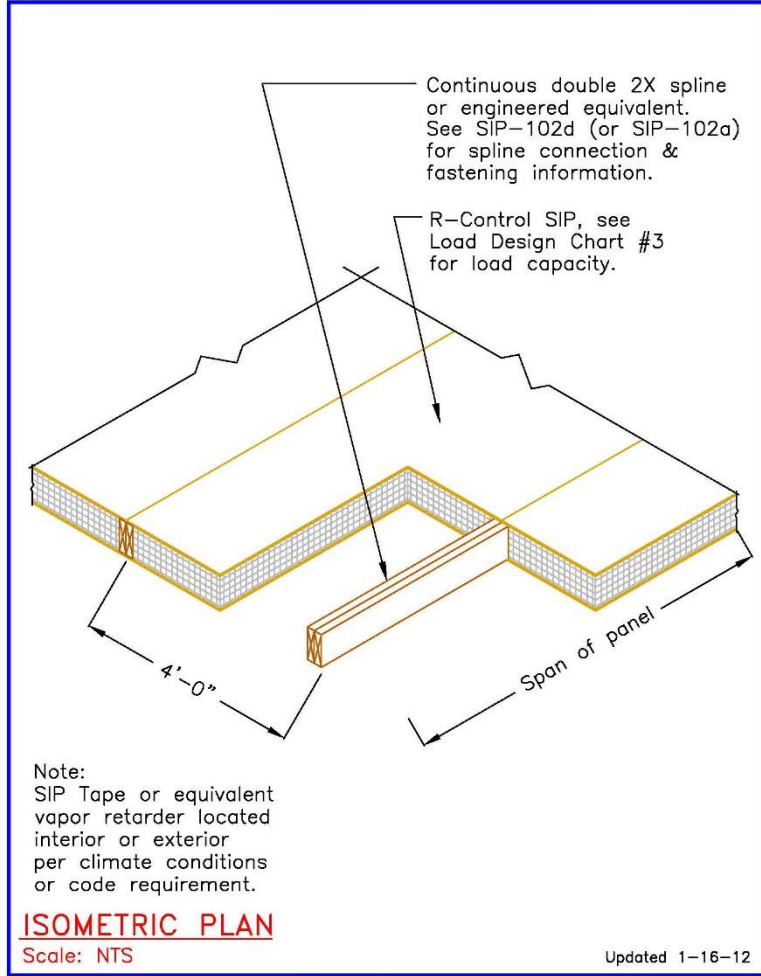

<b>R-Control® SIP</b>	
TITLE: Floor/Roof SIP 2X Connection	NO. SIP-108

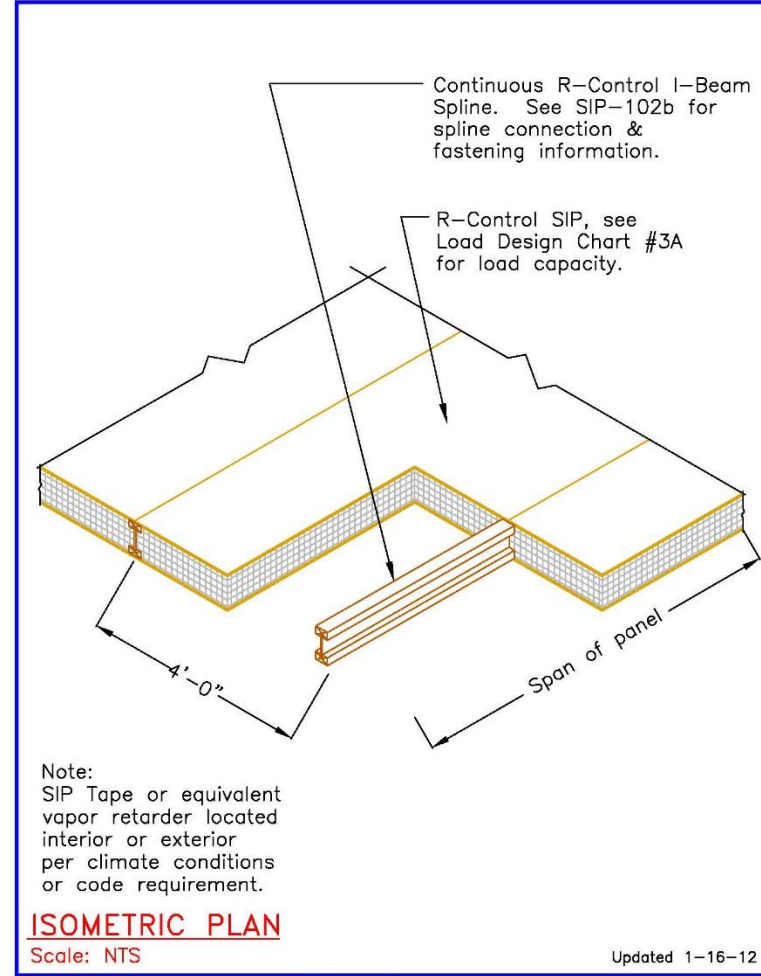

<b>R-Control® SIP</b>	
TITLE: Floor/Roof SIP I-Beam Connection	NO. SIP-108a

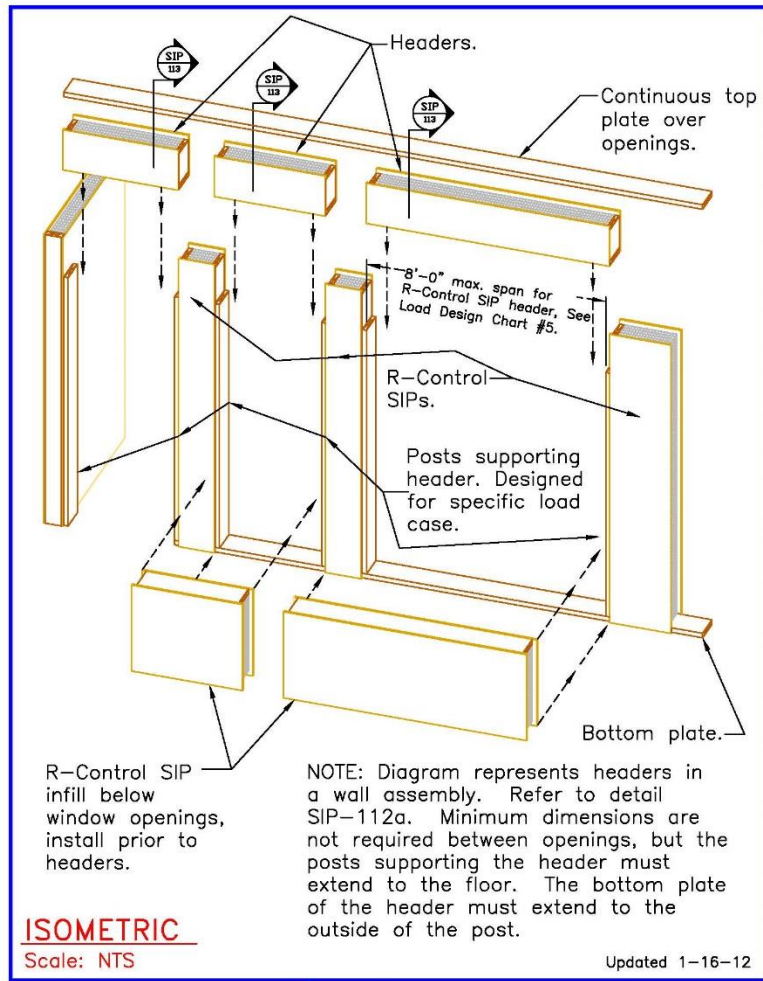

<b>R-Control® SIP</b>	
TITLE:	NO.
Headers	SIP-112

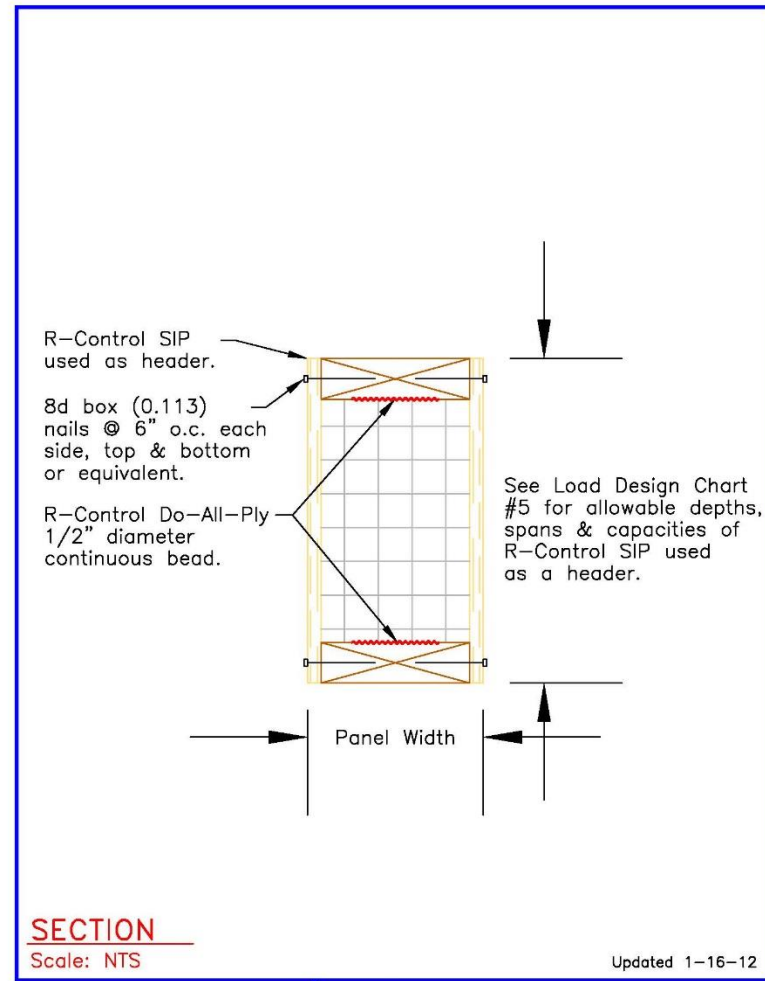

<b>R-Control® SIP</b>	
TITLE:	NO.
SIP Header Plates	SIP-113

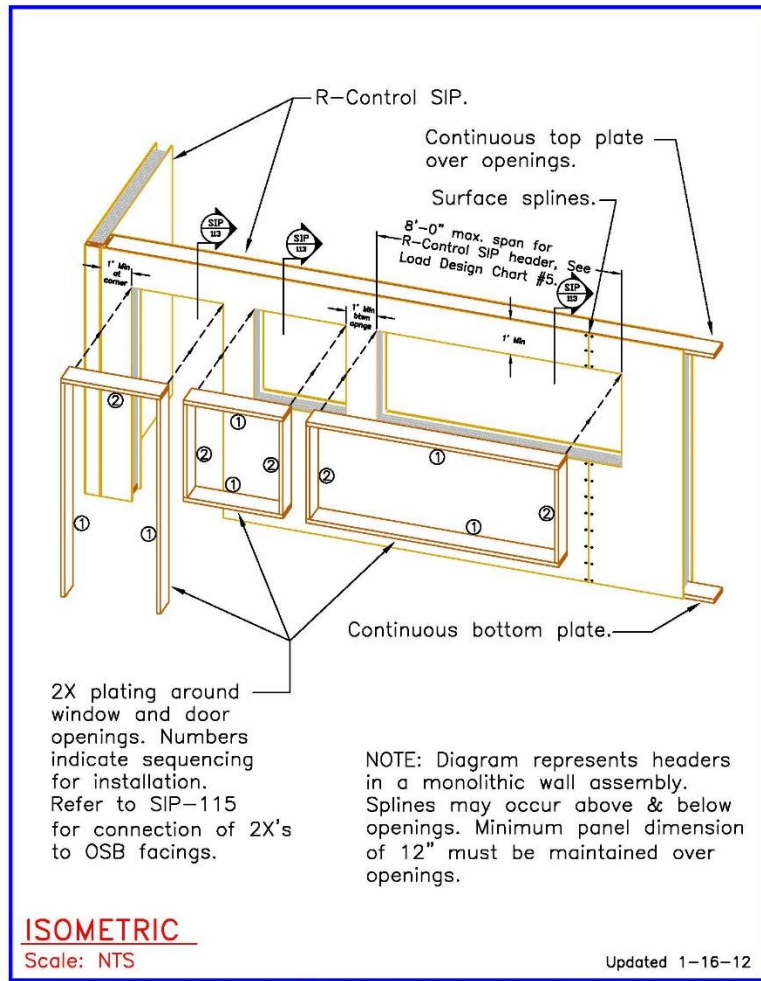

<b>R-Control® SIP</b>	
TITLE: SIP Header	NO. SIP-114

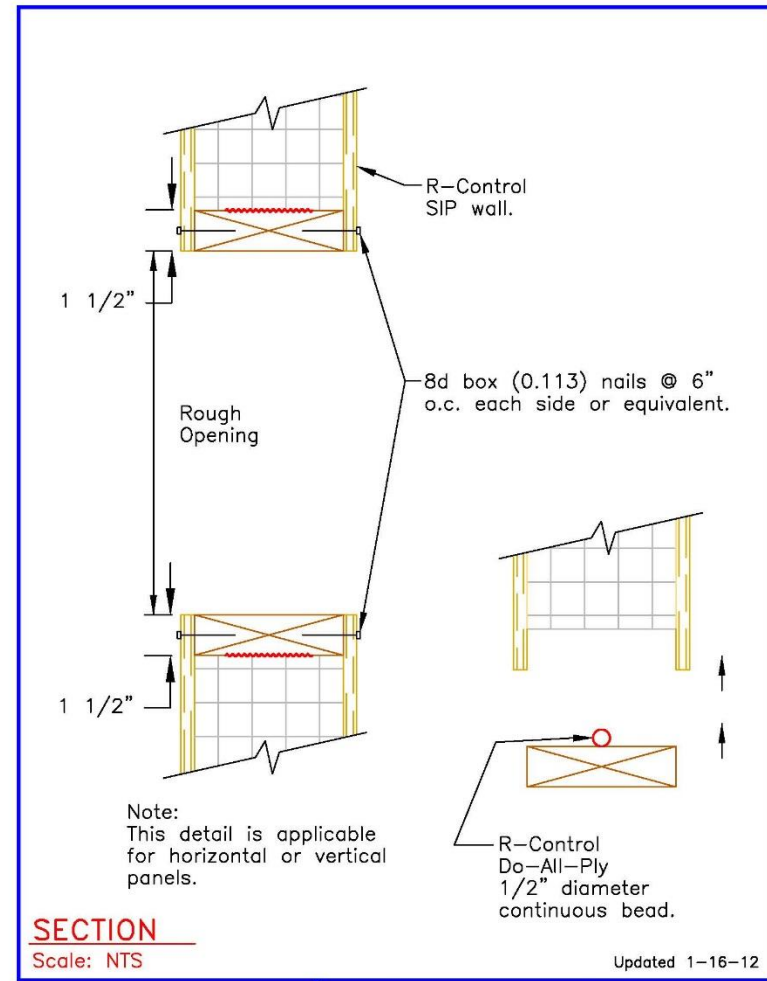

<b>R-Control® SIP</b>	
TITLE: Openings in SIPs	NO. SIP-115

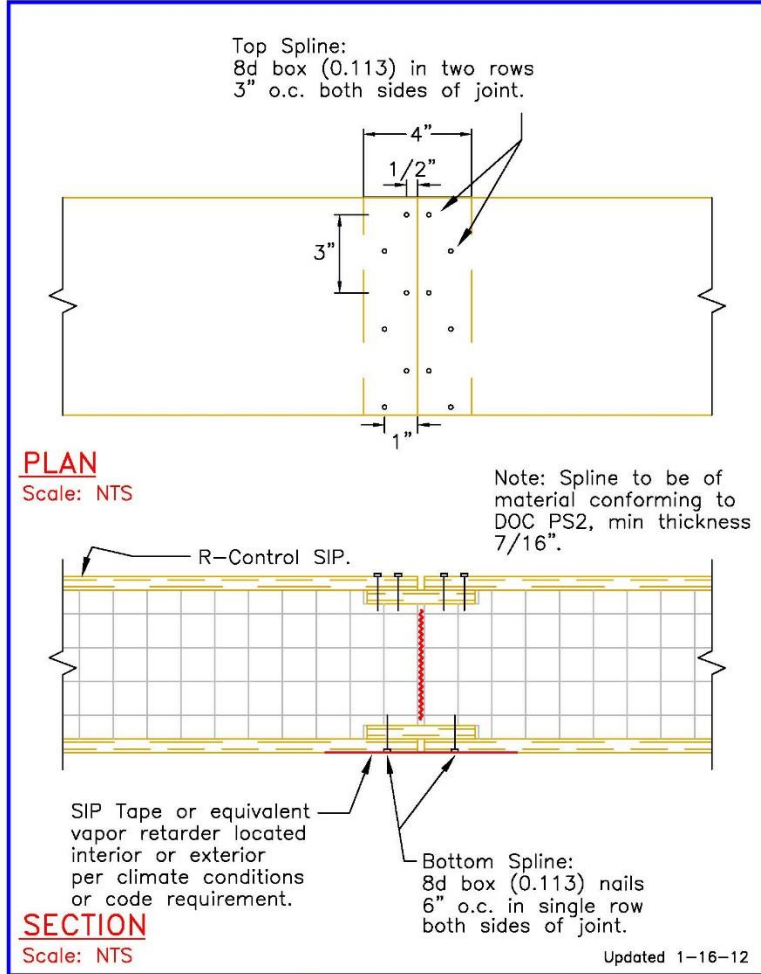

<b>R-Control® SIP</b>	
TITLE: Diaphragm Connection - Splines	NO. SIP-139a

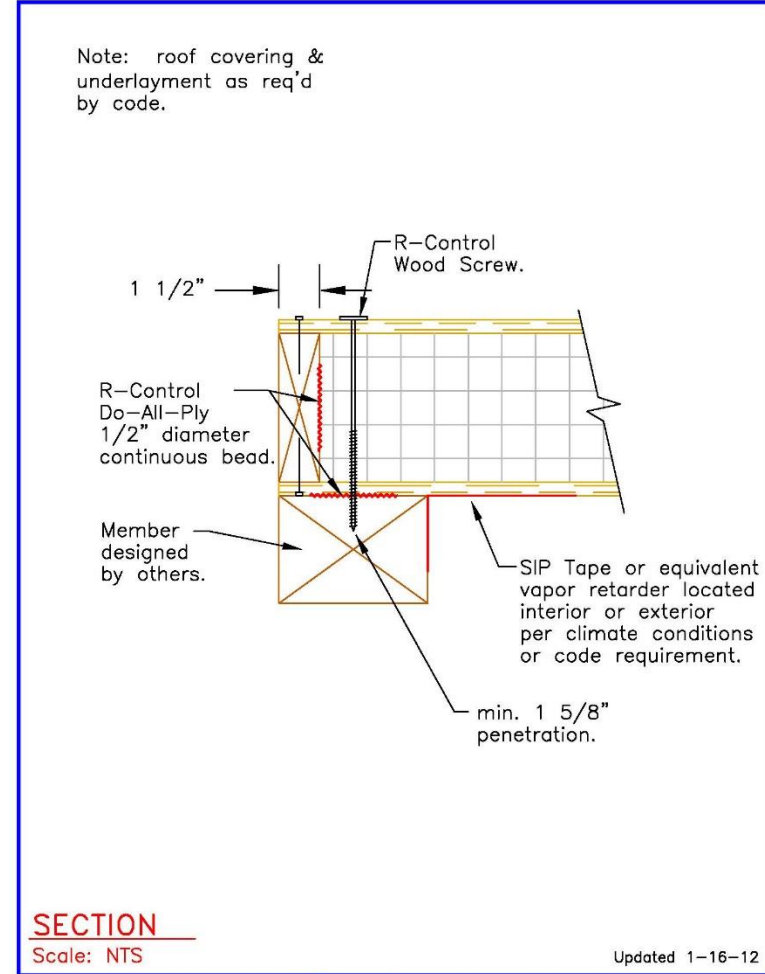

<b>R-Control® SIP</b>	
TITLE: Diaphragm Connection - Support Member	NO. SIP-140

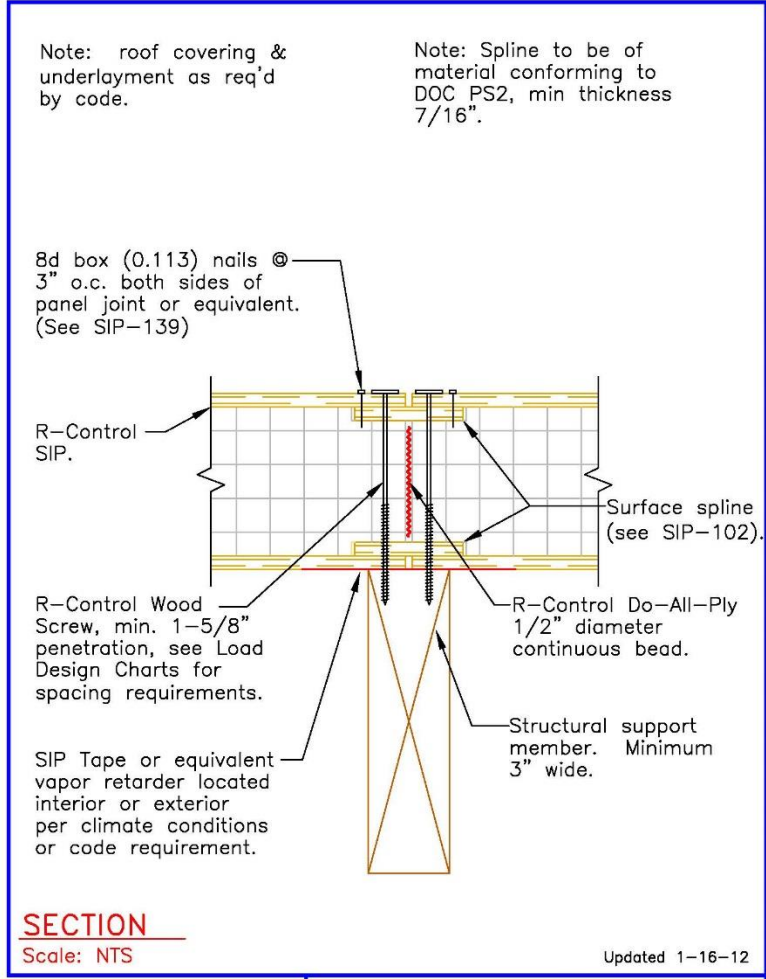

<b>R-Control® SIP</b>	
TITLE: Diaphragm Connection - Intermediate support	NO. SIP-141