

REVISIONS			
REV	DESCRIPTION	DATE	APPROVED

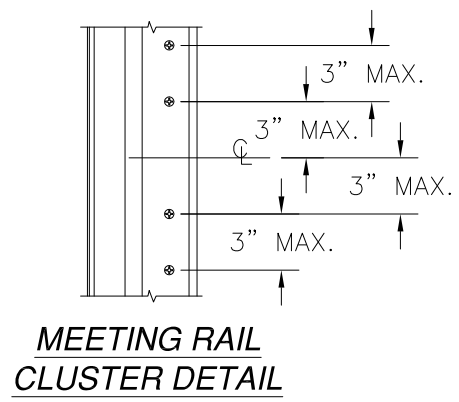
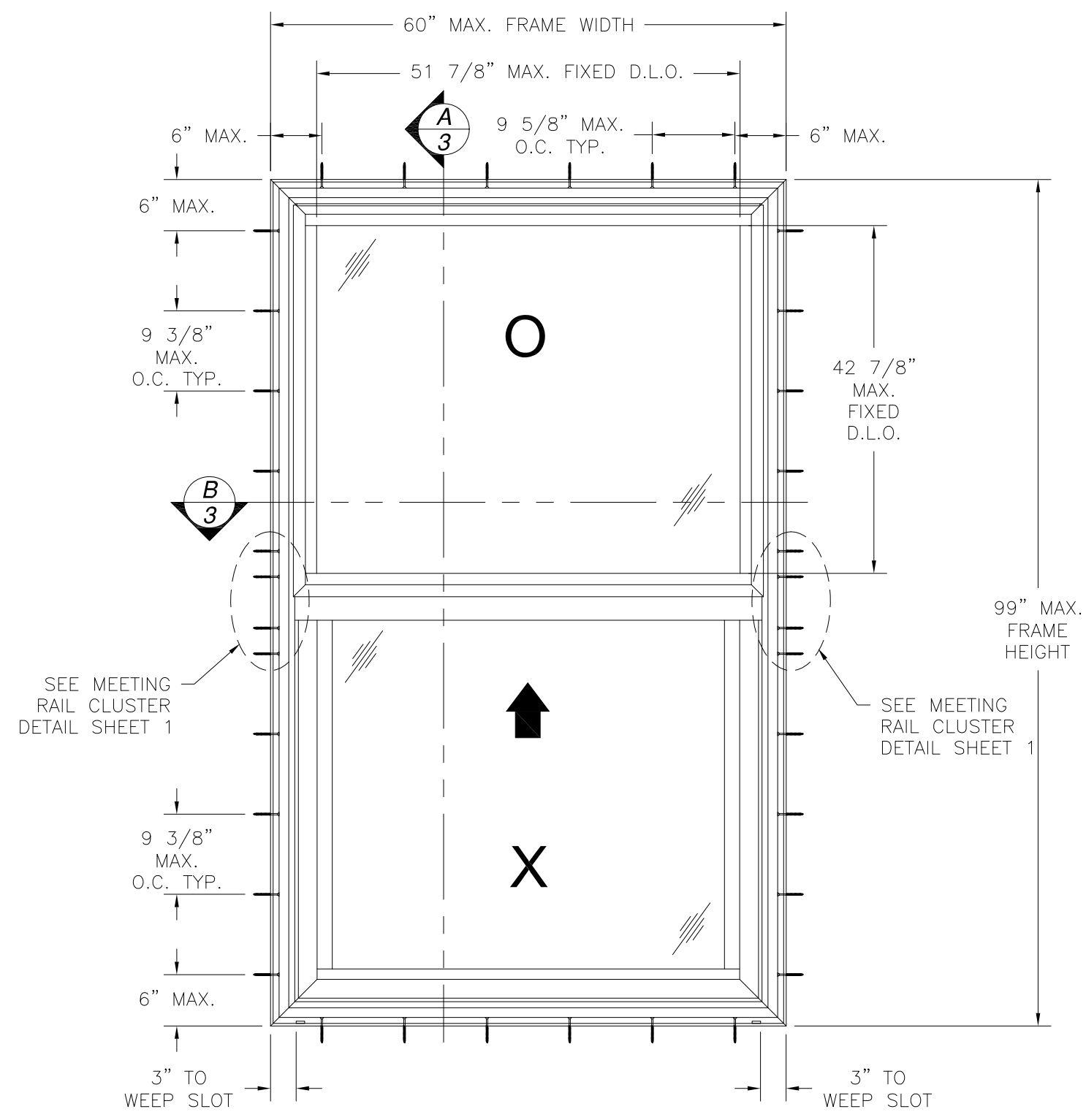

- NOTES:
- 1) THE PRODUCT SHOWN HEREIN IS DESIGNED AND MANUFACTURED TO COMPLY WITH REQUIREMENTS OF THE 2006 INTERNATIONAL BUILDING CODE AND 2006 INTERNATIONAL RESIDENTIAL CODE WITH TEXAS STATE MODIFICATIONS.
 - 2) WOOD FRAMING, 2X BACKED STEEL FRAMING AND MASONRY OPENING TO BE DESIGNED AND ANCHORED TO PROPERLY TRANSFER ALL LOADS TO STRUCTURE. FRAMING AND MASONRY OPENING IS THE RESPONSIBILITY OF THE ARCHITECT OR ENGINEER OF RECORD.
 - 3) 1X BUCK OVER MASONRY/CONCRETE IS OPTIONAL. WHERE 1X BUCK IS NOT USED DISSIMILAR MATERIALS MUST BE SEPARATED WITH APPROVED COATING OR MEMBRANE. SEPARATION OF DISSIMILAR MATERIALS IS THE RESPONSIBILITY OF THE ARCHITECT OR ENGINEER OF RECORD.
 - 4) ALLOWABLE STRESS INCREASE OF 1/3 WAS NOT USED IN THE DESIGN OF THE PRODUCT SHOWN HEREIN. WIND LOAD DURATION FACTOR Cd=1.6 WAS USED FOR WOOD ANCHOR CALCULATIONS.
 - 5) FRAME AND SASH MATERIAL: RIGID PVC .071" THICK.
 - 6) UNITS MUST BE GLAZED PER ASTM E1300. SEE SHEET 8 FOR GLAZING OPTIONS.
 - 7) APPROVED IMPACT PROTECTIVE SYSTEM IS NOT REQUIRED FOR THIS PRODUCT IN WIND BORNE DEBRIS REGIONS.
 - 8) SHIM AS REQUIRED AT EACH INSTALLATION ANCHOR WITH LOAD BEARING SHIM. SHIM WHERE SPACE OF 1/16" OR GREATER OCCURS. MAXIMUM ALLOWABLE SHIM STACK TO BE 1/4".
 - 9) FOR ANCHORING INTO MASONRY USE 1/4" ITW OR 1/4" ELCO ULTRACON TAPCONS WITH SUFFICIENT LENGTH TO ACHIEVE A 1 1/4" MINIMUM EMBEDMENT INTO SUBSTRATE WITH 2 1/2" MINIMUM EDGE DISTANCE. LOCATE ANCHORS AS SHOWN IN ELEVATIONS AND INSTALLATION DETAILS.
 - 10) FOR ANCHORING INTO 2X WOOD FRAMING, 2X BUCK, OR 2X BACKED 20GA. STEEL FRAMING USE #12 WOOD SCREW WITH SUFFICIENT LENGTH TO ACHIEVE A 1 9/16" MINIMUM EMBEDMENT INTO SUBSTRATE. LOCATE ANCHORS AS SHOWN IN ELEVATIONS AND INSTALLATION DETAILS.
 - 11) ALL FASTENERS TO BE CORROSION RESISTANT.
 - 12) INSTALLATION ANCHORS SHALL BE INSTALLED IN ACCORDANCE WITH ANCHOR MANUFACTURER'S INSTALLATION INSTRUCTIONS, AND ANCHORS SHALL NOT BE USED IN SUBSTRATES WITH STRENGTHS LESS THAN THE MINIMUM STRENGTH SPECIFIED BELOW:
 - A. WOOD – MINIMUM SPECIFIC GRAVITY OF G=0.42
 - B. CONCRETE – MINIMUM COMPRESSIVE STRENGTH OF 3,192 PSI.
 - C. MASONRY – STRENGTH CONFORMANCE TO ASTM C-90, GRADE N, TYPE 1 (OR GREATER).
 - D. STEEL FRAMING: 2X BACKED 20GA. (.039" MIN.) STEEL FRAMING.
 - 13) MAXIMUM SASH SIZE: 54 3/4" x 48 1/2".
MAXIMUM SASH D.L.O. SIZE: 49 1/4" x 43 3/4".

**SERIES V-200 PVC SINGLE HUNG
EQUAL LITE WINDOW
EXTERIOR VIEW**

DESIGN PRESSURE RATING	IMPACT RATING
±60.0PSF	NONE

TABLE OF CONTENTS	
SHEET NO.	DESCRIPTION
1	ELEVATION, ANCHORING LAYOUT, DETAIL AND NOTES
2	BILL OF MATERIALS AND CORNER DETAILS
3	CROSS SECTIONS
4 – 6	INSTALLATION DETAILS
7 – 8	COMPONENTS AND GLAZING OPTIONS

WinDoor
INCORPORATED

7500 AMSTERDAM DRIVE
ORLANDO, FL 32832
Phone: 407.481.8400
Fax: 407.481.0505 www.windoorinc.com

**SERIES V-200 PVC SINGLE HUNG WINDOW
60" x 99" – NON-IMPACT
ELEVATION, ANCHORING LAYOUT, DETAIL AND NOTES**

DRAWN: TJH DWG NO. 08-01212 REV -

SCALE NTS DATE 02/02/11 SHEET 1 OF 8

SIGNED: 02/17/2011

Luis R. Lomas P.E.
Texas No. 101889

PARTS LIST				
NO.	PART NUMBER	DESCRIPTION	MANUFACTURER	MATERIAL
1	SS8701	MAIN FRAME	VEKA	RIGID PVC
2	SE8746	SASH TOP RAIL	VEKA	RIGID PVC
3	SE8747	SASH BOTTOM RAIL	VEKA	RIGID PVC
4	SE8745	SASH STILE	VEKA	RIGID PVC
5	SS8704	FIXED MEETING RAIL	VEKA	RIGID PVC
6	SE8735	FIXED GLASS STOP	VEKA	RIGID PVC
7	AC82	FIXED SASH COVER	MOR-X	RIGID PVC
8	AC83	FIXED SASH DRIP CAP	MOR-X	RIGID PVC
9	AC87	FRAME HEAD COVER	MOR-X	RIGID PVC
10	AC88	BALANCE COVER	MOR-X	RIGID PVC
11	AC89	SASH STOP	MOR-X	RIGID PVC
12	AC91	FRAME SILL FILLER	MOR-X	RIGID PVC
13	BV159	1" GLASS STOP	MOR-X	RIGID PVC
14	V20-AC-04	1 1/4" GLASS STOP	MOR-X	RIGID PVC
15		SILL SCREEN TRACK		RIGID PVC
16	FS-05666	JAMB ADAPTOR FOR BALANCE SHOE	KEYMARK	ALUMINUM 6063-T6
17	FS-05667	FIXED SASH REINFORCEMENT	KEYMARK	ALUMINUM 6063-T6
18	FS-05668	SASH STILE REINFORCEMENT	KEYMARK	ALUMINUM 6063-T6
19	FS-05669	SASH TOP RAIL REINFORCEMENT	KEYMARK	ALUMINUM 6063-T6
20	FH-05670	SASH BOTTOM RAIL REINFORCEMENT	KEYMARK	ALUMINUM 6063-T6
21	FS-05671	INSTALLATION SCREW ANTI-SHEAR	KEYMARK	ALUMINUM 6063-T6
22	FS-05672	FIXED SASH ATTACH. SCREW BACKUP	KEYMARK	ALUMINUM 6063-T6
23	FH-05673	FIXED MRAIL ATTACH SCREW BACKUP	KEYMARK	ALUMINUM 6063-T6
24	FH-05674	FIXED SASH REINFORCEMENT	KEYMARK	ALUMINUM 6063-T6
25	FH-05675	SILL WATERDAM EXTENDER	KEYMARK	ALUMINUM 6063-T6
26	904X-AC-16	SNAP LATCH HANDLE	BONNELL	RIGID PVC
27	ULTRALIFT	.625 DIA. SPIRAL BALANCER	CALDWELL	
28	21B137	TILT BALANCE SHOE	CALDWELL	
29	16Y498	TILT BALANCE PIVOT BAR	CALDWELL	
30	SKK04-0005	AUTO LOCK BODY	INTERLOCK USA	
31	SK01-00100	AUTO LOCK COVER	INTERLOCK USA	
32	SK01-3012	AUTO LOCK KEEPER	INTERLOCK USA	
33	TL1625-CH	RH/LH TILT LATCH ASSEMBLY	FOUR JAKS	
34		NON-IMPACT GLAZING		
35		2" x 1 1/2" x 1/8" SHIM	FRANK LOWE	EDPM DUROMETER 60
36		.240" H x .187" FINSEAL	ULTRAFAB	
37	E-201	FIXED SASH BULB SEAL	ULTRAFAB	VINYL
38	AP525	BOTTOM RAIL BULB SEAL	SCHLEGEL	VINYL
39		WEEP SLOT COVER		PLASTIC
40		#6 x 5/8" FH-A LOCK/KEEPER		

REVISIONS			
REV	DESCRIPTION	DATE	APPROVED

PARTS LIST				
NO.	PART NUMBER	DESCRIPTION	MANUFACTURER	MATERIAL
41		#6 x 3/4" PH PIVOT BAR TEK		
42		#8 x 1" FH-A BALANCER SCREW		
43		#10 x 1 1/4" TEK FIXED SASH		
44		#10 x 1 1/2" PH-A OUTER FIXED		
45		#10 x 3" PH-A INNER FIXED		
46	SIKAFLEX 552	GLAZING COMPOUND	SIKA CORP.	SILANE POLYMER
47		SCREW HOLE PLUG	VEKA	RIGID PVC
48		SCREEN MESH		FIBERGLASS MESH
49		SCREEN FRAME		RIGID PVC
50		SCREEN SPLINE		

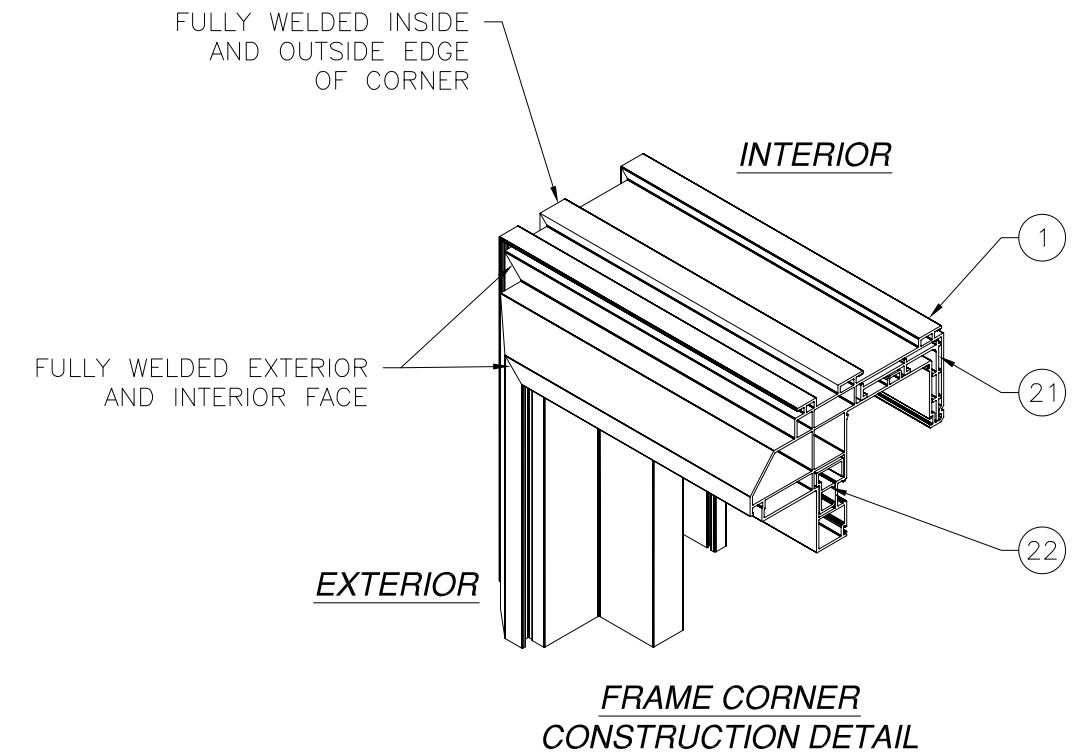
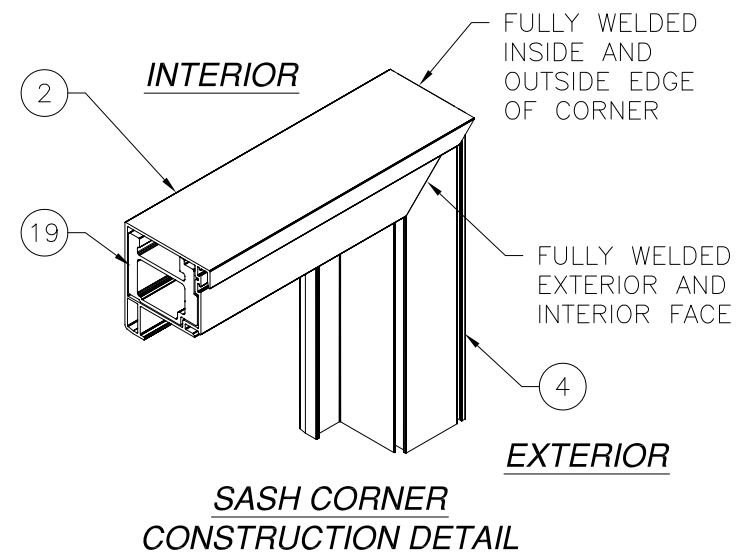

WinDoor INCORPORATED 7500 AMSTERDAM DRIVE
 ORLANDO, FL 32832
 Phone: 407.481.8400 Fax: 407.481.0505 www.windoorinc.com

SERIES V-200 PVC SINGLE HUNG WINDOW
 60" x 99" - NON-IMPACT
 BILL OF MATERIALS AND CORNER DETAILS

DRAWN: TJH	DWG NO. 08-01212	REV -
SCALE NTS	DATE 02/02/11	SHEET 2 OF 8

Luis R. Lomas P.E.
 Texas No. 101889

REVISIONS			
REV	DESCRIPTION	DATE	APPROVED

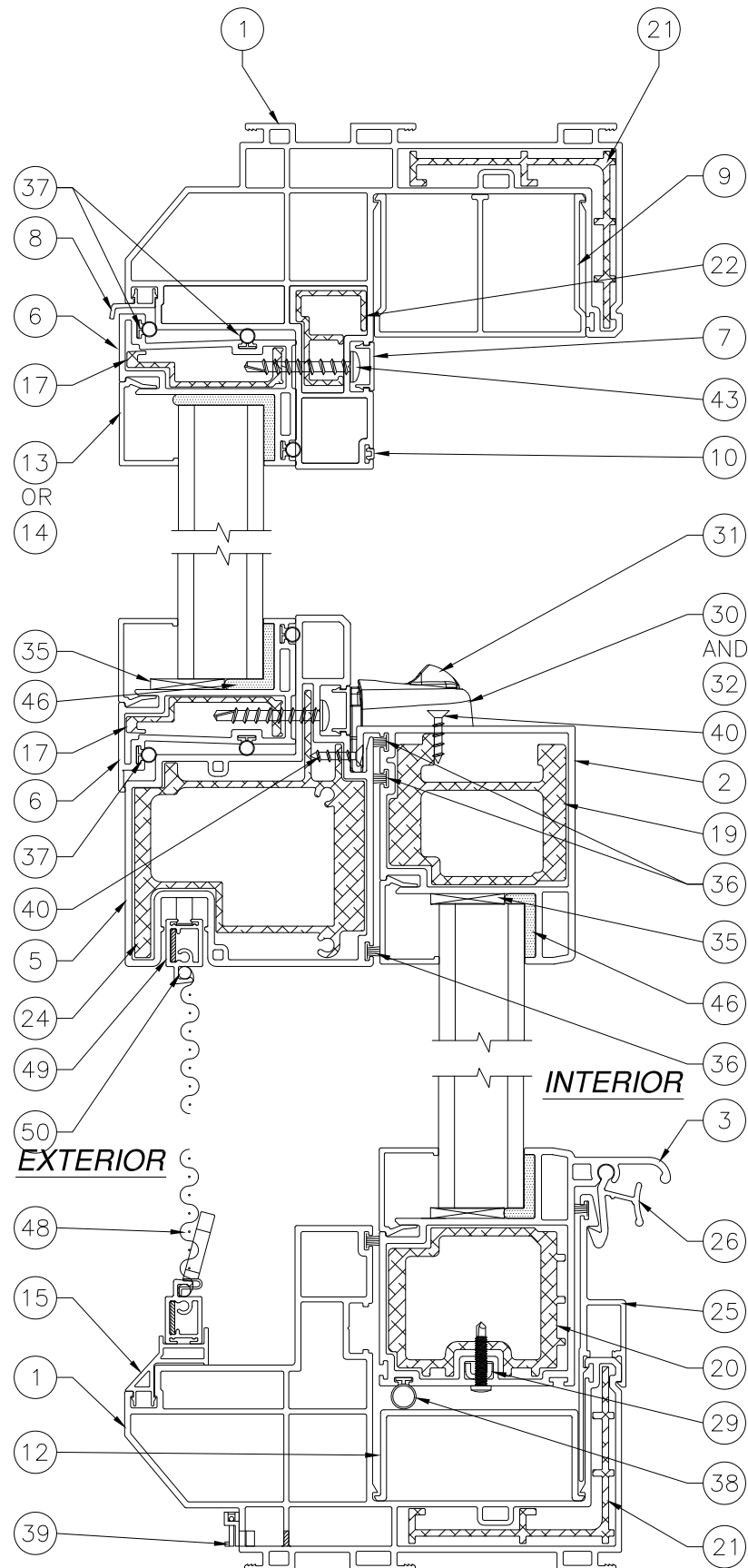

A
3 VERTICAL CROSS SECTION
DOUBLE GLAZED SHOWN, TRIPLE GLAZED SIMILAR

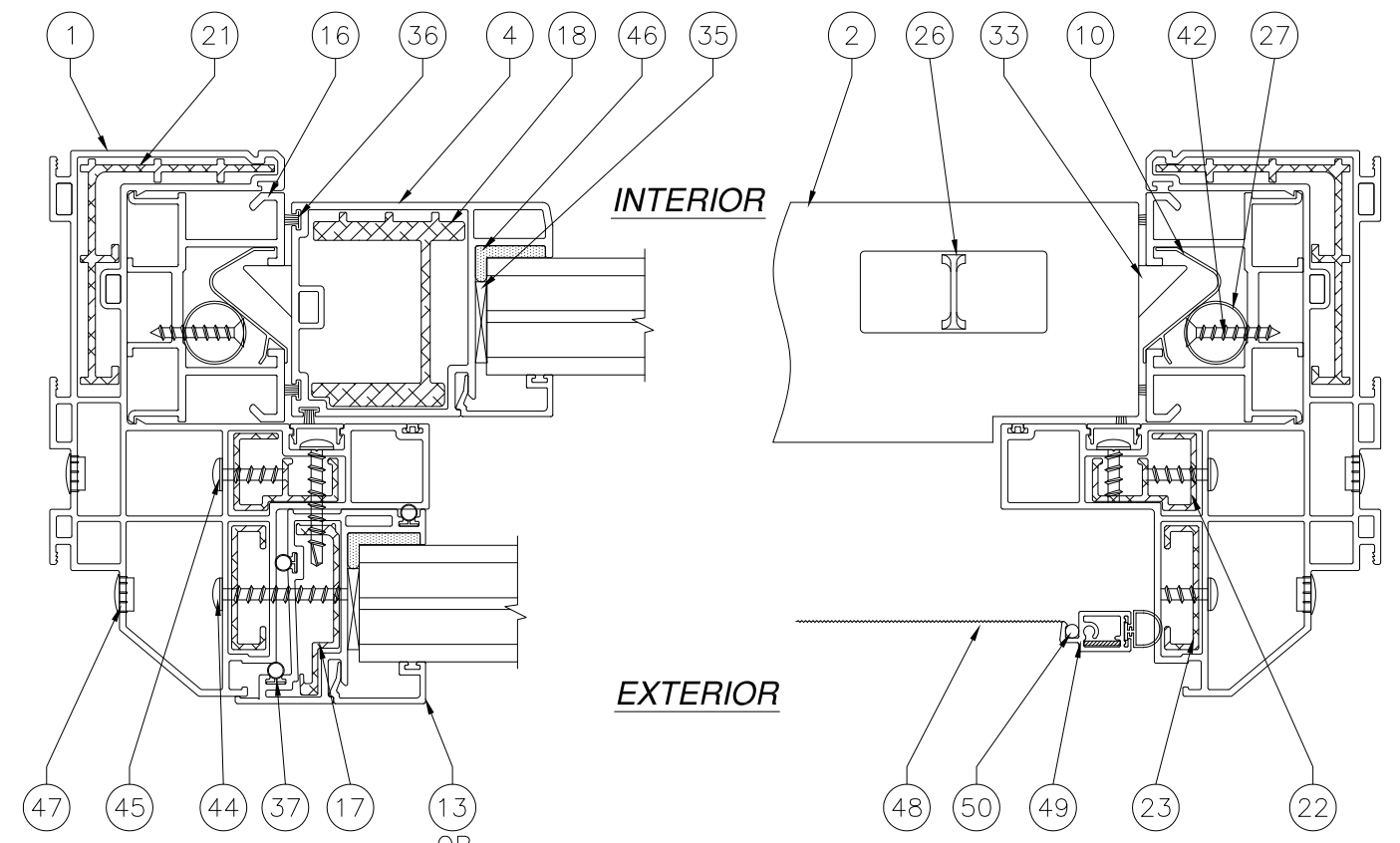

B
3 HORIZONTAL CROSS SECTION
TRIPLE GLAZED SHOWN, DOUBLE GLAZED SIMILAR

WinDoor INCORPORATED		7500 AMSTERDAM DRIVE ORLANDO, FL 32832 Phone: 407.481.8400 Fax: 407.481.0505 www.windowinc.com
SERIES V-200 PVC SINGLE HUNG WINDOW 60" x 99" - NON-IMPACT CROSS SECTIONS		
DRAWN: TJH	DWG NO. 08-01212	REV -
SCALE NTS	DATE 02/02/11	SHEET 3 OF 8

Luis R. Lomas P.E.
Texas No. 101889

REVISIONS			
REV	DESCRIPTION	DATE	APPROVED

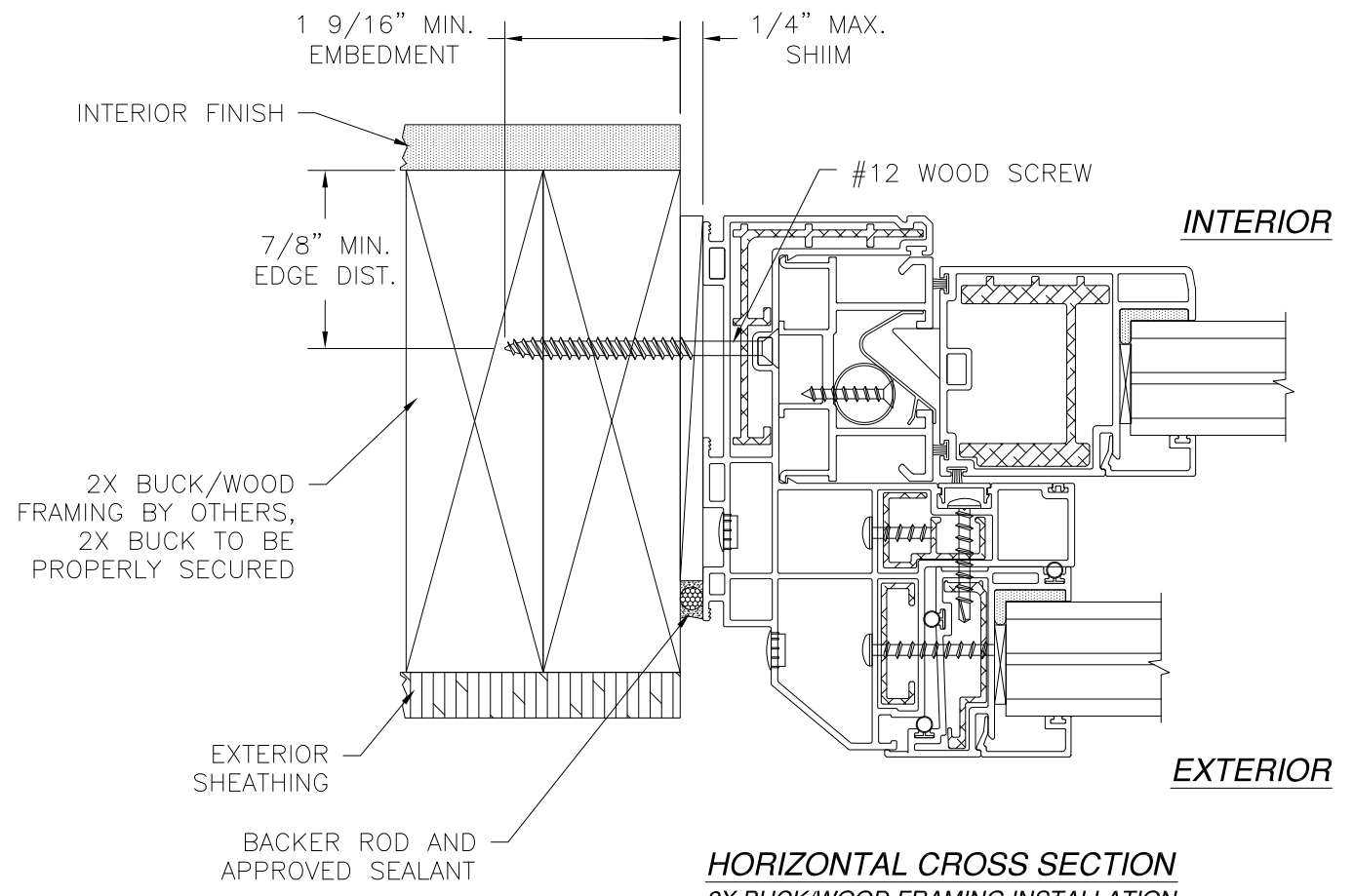
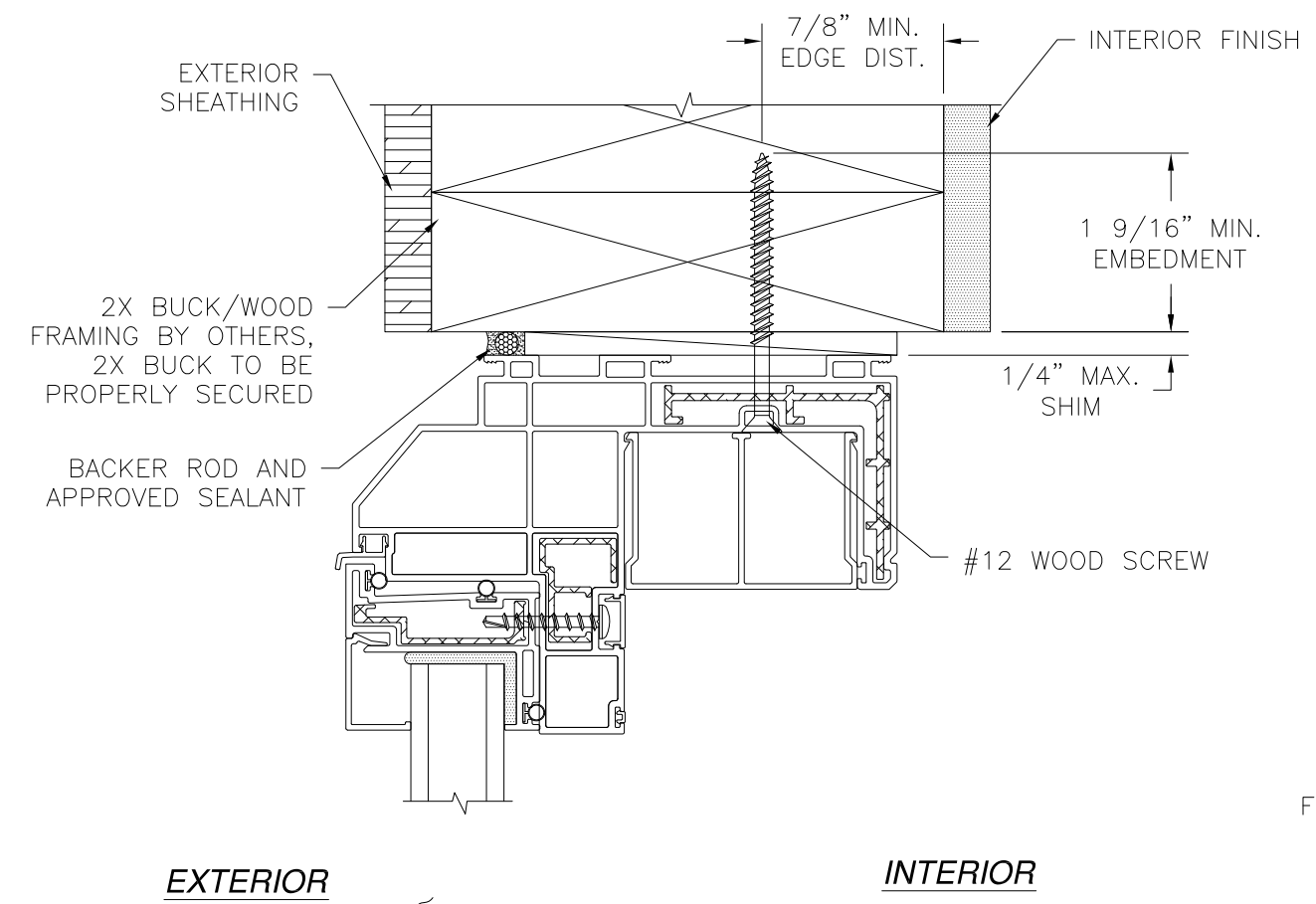

HORIZONTAL CROSS SECTION
 2X BUCK/WOOD FRAMING INSTALLATION
 TRIPLE GLAZED SHOWN, DOUBLE GLAZED SIMILAR

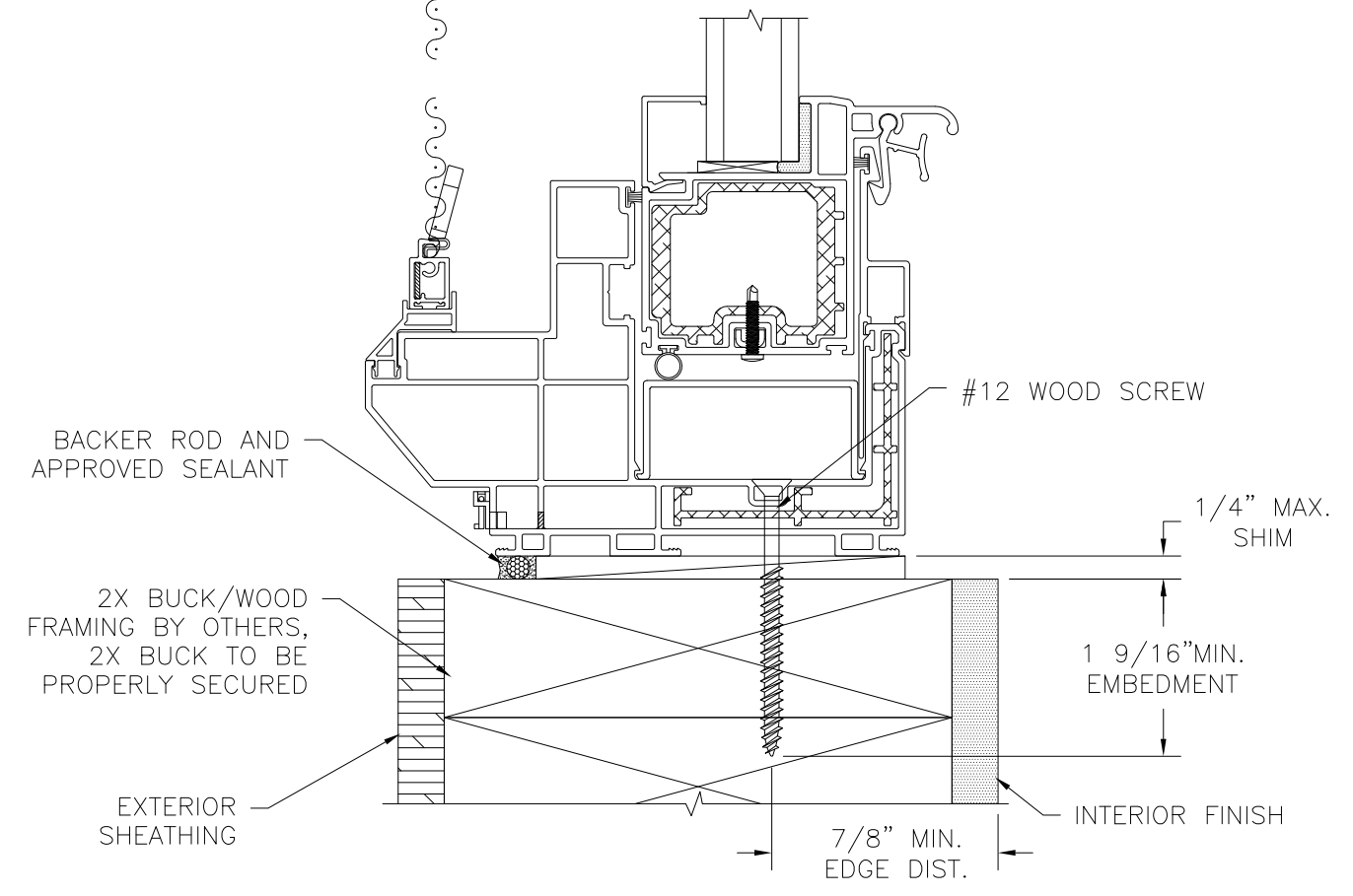

VERTICAL CROSS SECTION
 2X BUCK/WOOD FRAMING INSTALLATION
 DOUBLE GLAZED SHOWN, TRIPLE GLAZED SIMILAR

WinDoor INCORPORATED	7500 AMSTERDAM DRIVE	www.windowinc.com Phone: 407.481.8400 Fax: 407.481.0505
	ORLANDO, FL 32832	
SERIES V-200 PVC SINGLE HUNG WINDOW 60" x 99" - NON-IMPACT INSTALLATION DETAILS		
DRAWN: TJH	DWG NO. 08-01212	REV -
SCALE NTS	DATE 02/02/11	SHEET 4 OF 8

STATE OF TEXAS
 LUIS R. LOMAS
 101889
 LICENSED PROFESSIONAL ENGINEER

Luis R. Lomas P.E.
 Texas No. 101889

REVISIONS			
REV	DESCRIPTION	DATE	APPROVED

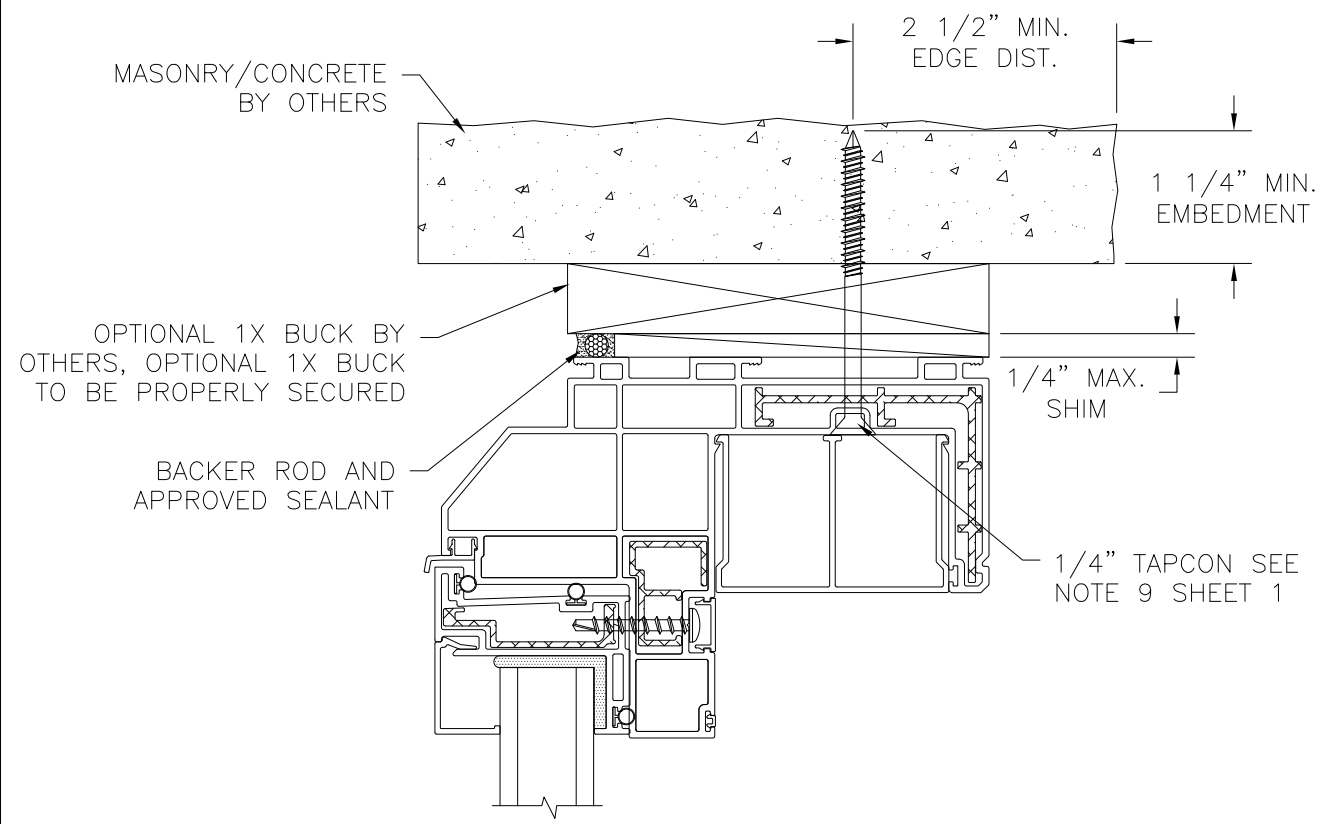

EXTERIOR

INTERIOR

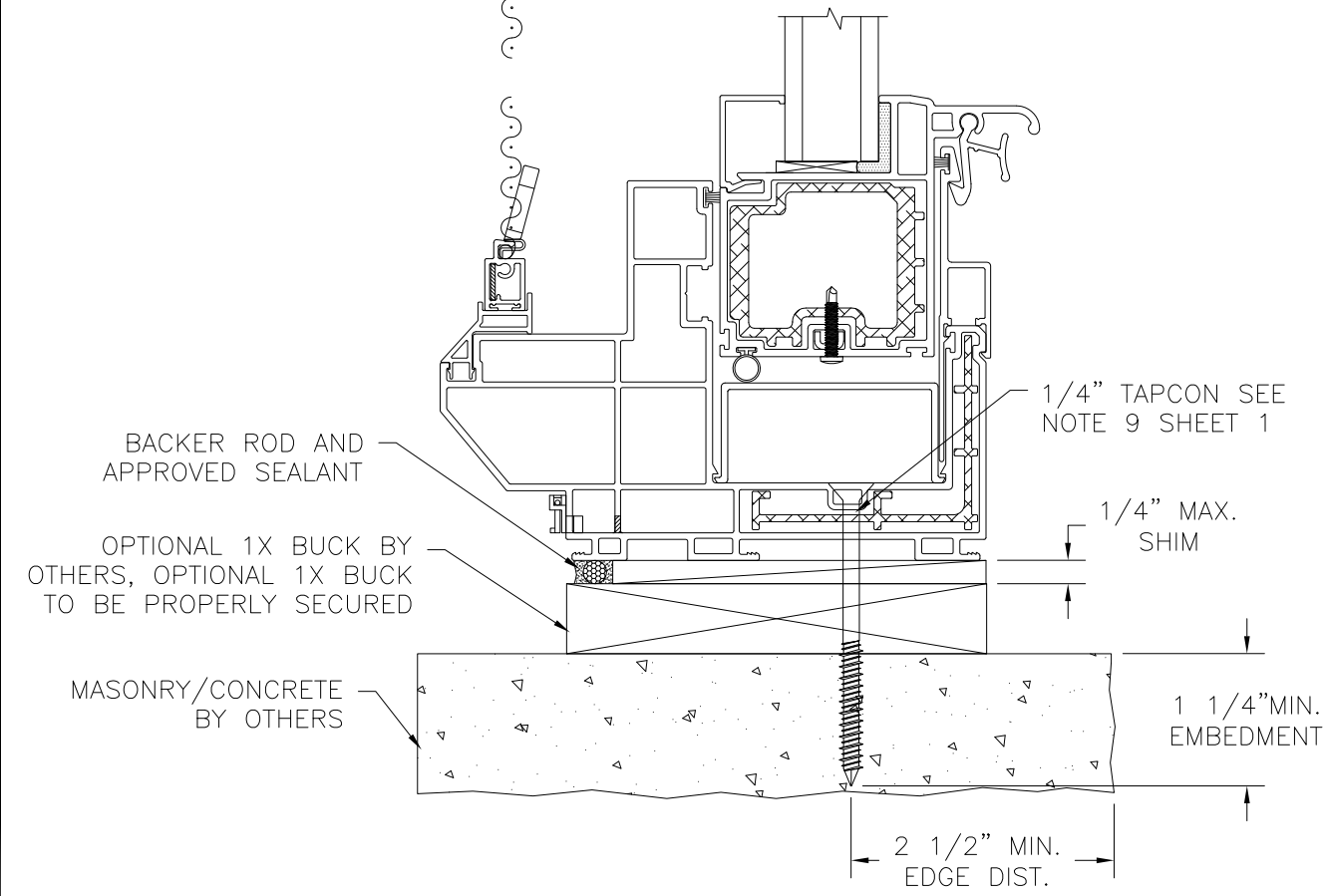

VERTICAL CROSS SECTION

MASONRY/CONCRETE INSTALLATION
DOUBLE GLAZED SHOWN, TRIPLE GLAZED SIMILAR

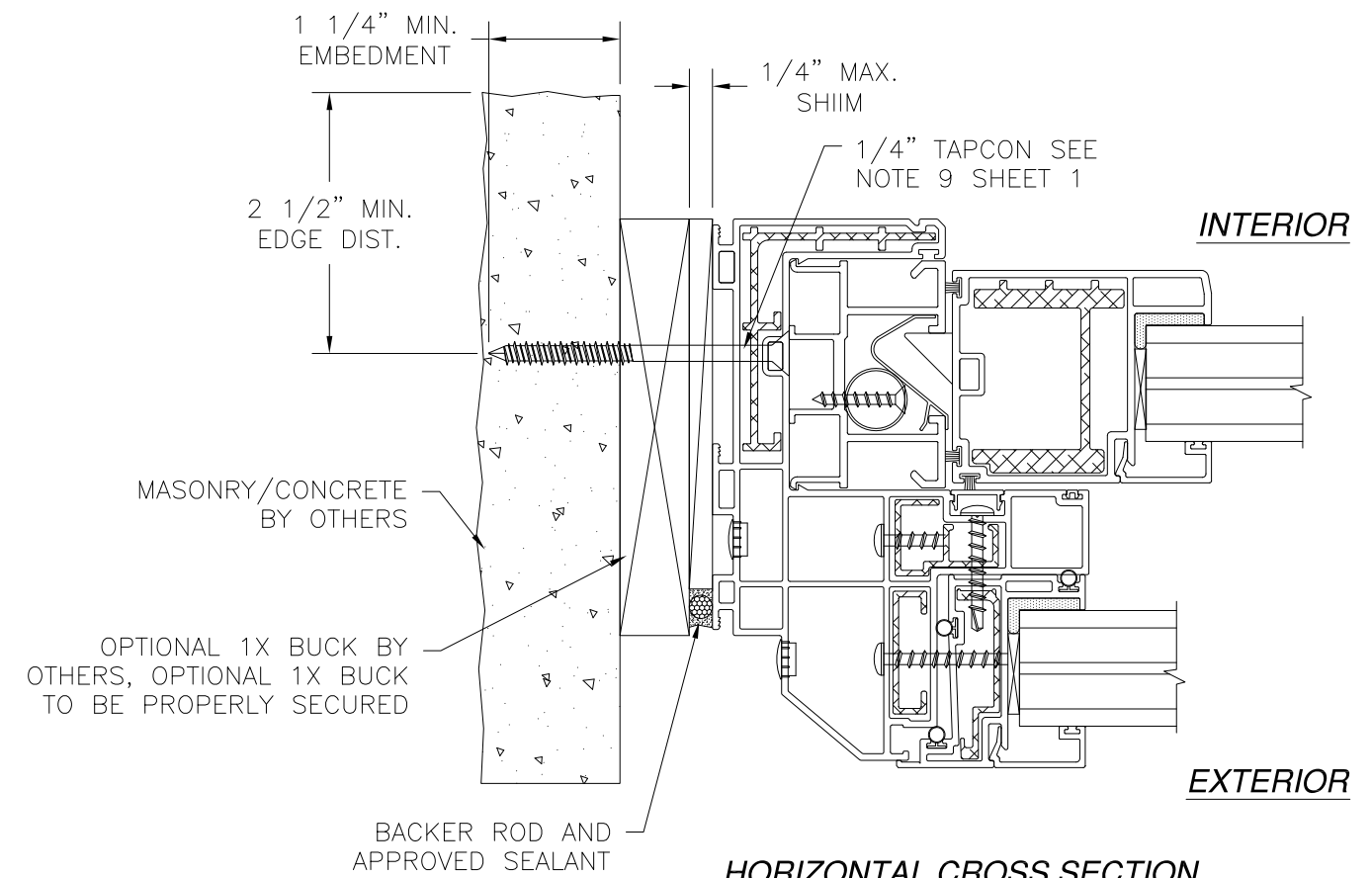

HORIZONTAL CROSS SECTION

MASONRY/CONCRETE INSTALLATION
TRIPLE GLAZED SHOWN, DOUBLE GLAZED SIMILAR

	7500 AMSTERDAM DRIVE ORLANDO, FL 32832	
	Phone: 407.481.8400 Fax: 407.481.0505	www.windoorinc.com
SERIES V-200 PVC SINGLE HUNG WINDOW 60" x 99" - NON-IMPACT INSTALLATION DETAILS		
DRAWN: TJH	DWG NO. 08-01212	REV -
SCALE NTS	DATE 02/02/11	SHEET 5 OF 8

Luis R. Lomas P.E.
Texas No. 101889

REVISIONS			
REV	DESCRIPTION	DATE	APPROVED

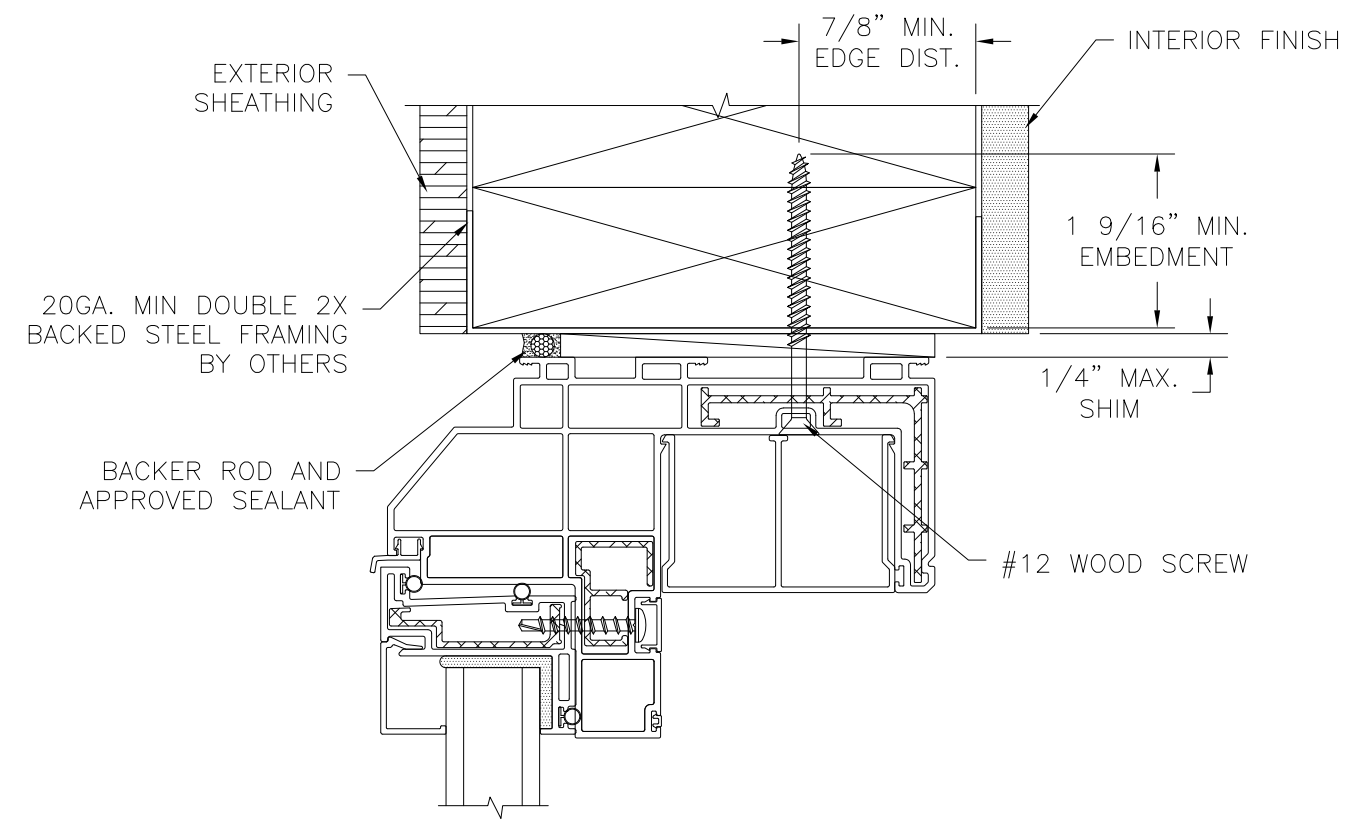

EXTERIOR

INTERIOR

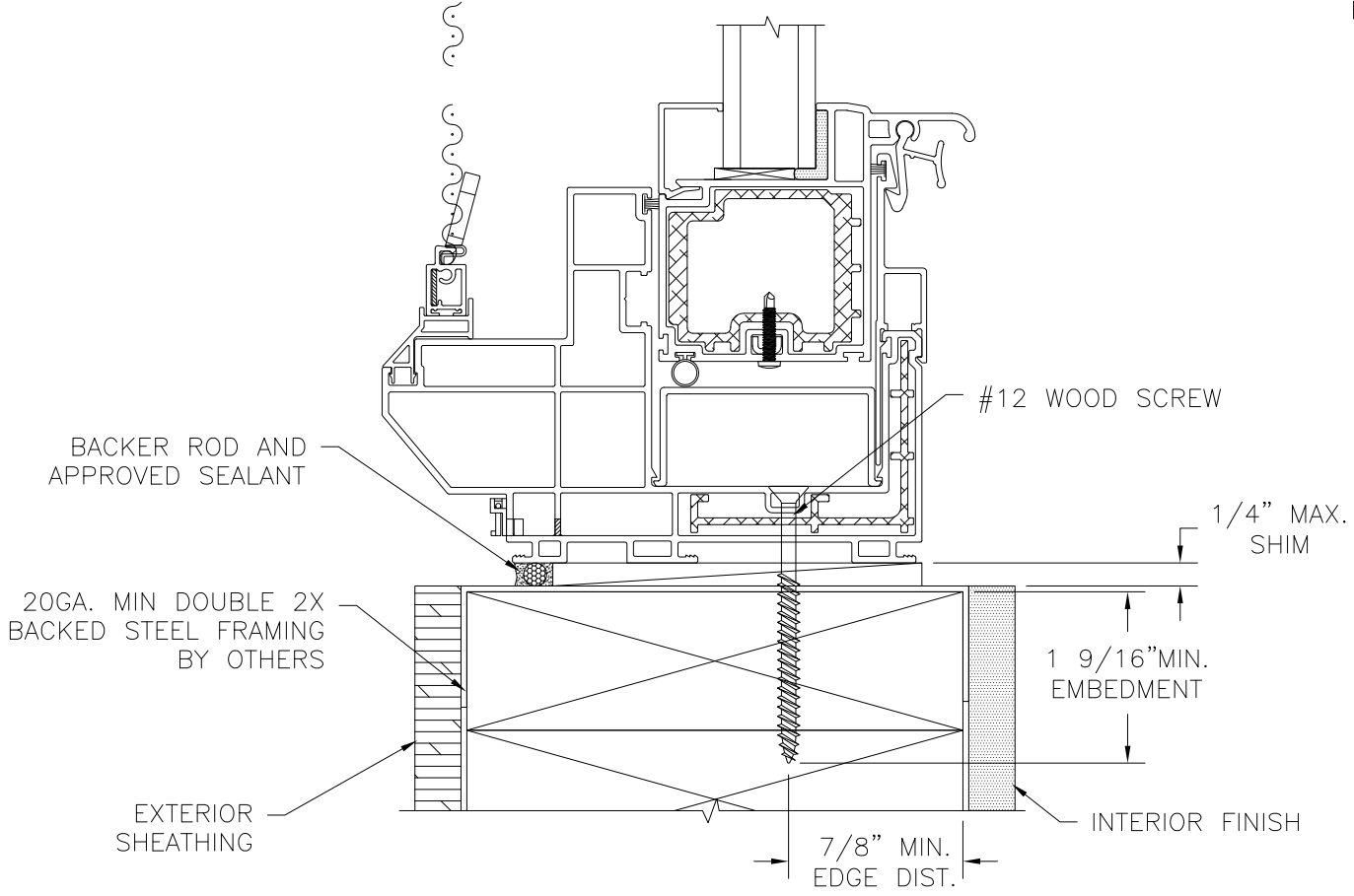

HORIZONTAL CROSS SECTION

20GA. MIN 2X BACKED STEEL FRAMING INSTALLATION
TRIPLE GLAZED SHOWN, DOUBLE GLAZED SIMILAR

VERTICAL CROSS SECTION
20GA. MIN 2X BACKED STEEL FRAMING INSTALLATION
DOUBLE GLAZED SHOWN, TRIPLE GLAZED SIMILAR

WinDoor INCORPORATED		7500 AMSTERDAM DRIVE ORLANDO, FL 32832 Phone: 407.481.8400 Fax: 407.481.0505 www.windoorinc.com
SERIES V-200 PVC SINGLE HUNG WINDOW 60" x 99" - NON-IMPACT INSTALLATION DETAILS		
DRAWN: TJH	DWG NO. 08-01212	REV -
SCALE NTS	DATE 02/02/11	SHEET 6 OF 8



Luis R. Lomas P.E.
Texas No. 101889

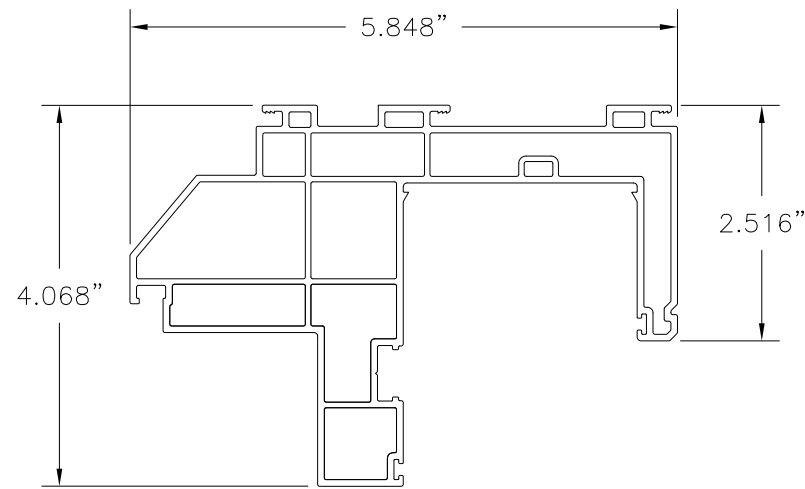

1 MAIN FRAME
EXTRUDED RIGID PVC .071" THICK

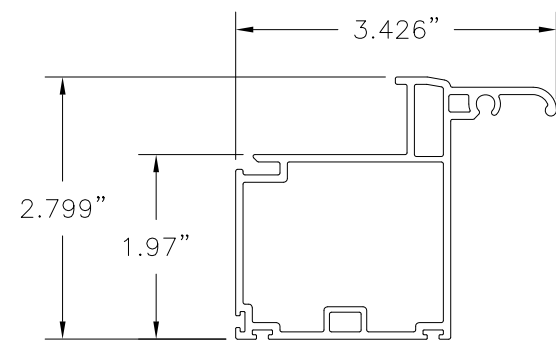

3 SASH BOTTOM RAIL
EXTRUDED RIGID PVC .079" THICK

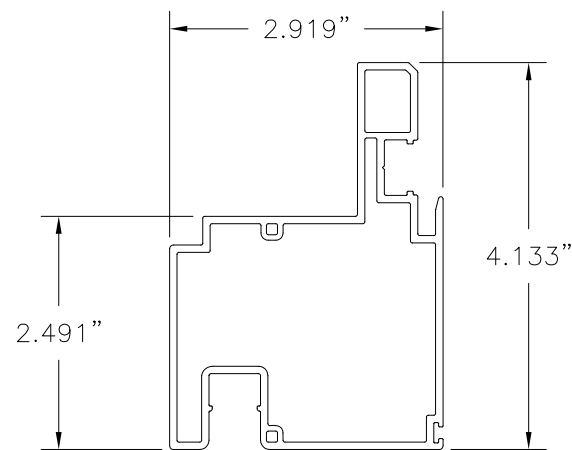

5 FIXED MEETING RAIL
EXTRUDED RIGID PVC .079" THICK

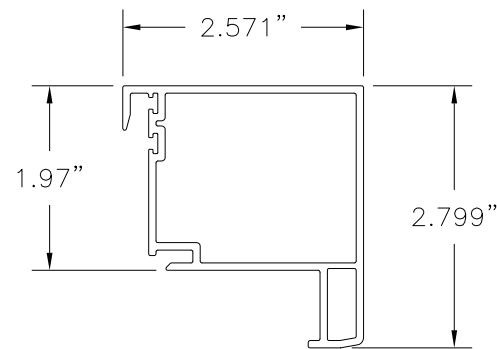

2 SASH TOP RAIL
EXTRUDED RIGID PVC .079" THICK

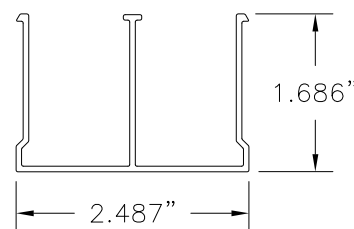

9 FRAME HEAD COVER
EXTRUDED RIGID PVC .059" THICK

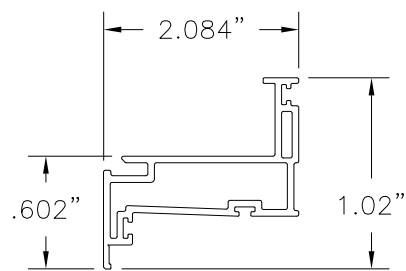

6 FIXED GLASS STOP
EXTRUDED RIGID PVC .071" THICK

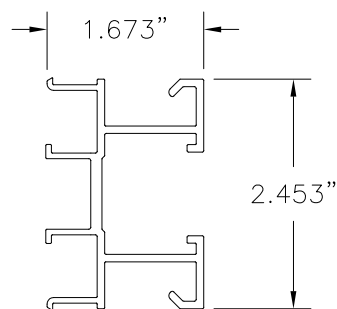

16 JAMB ADAPTER FOR BALANCE SHOE
EXTRUDED RIGID PVC .080" THICK

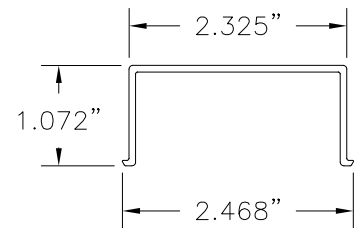

12 FRAME SILL FILLER
EXTRUDED RIGID PVC .071" THICK

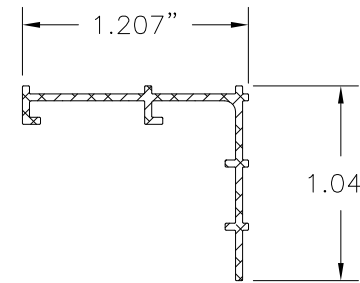

21 INSTALLATION SCREW ANTI-SHEAR
ALUMINUM 6063-T6 .075" THICK

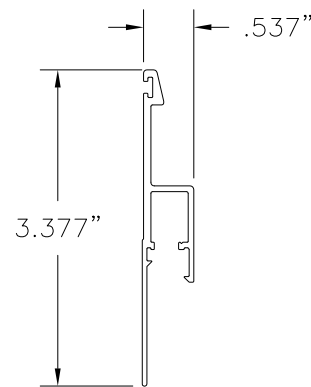

25 SILL WATERDAM EXTENDER
EXTRUDED RIGID PVC .060" THICK

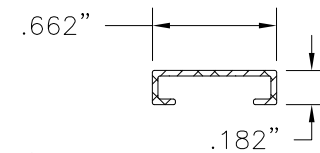

23 FIXED MEETING RAIL ATTACHMENT SCREW BACKUP
ALUMINUM 6063-T6 .060" THICK

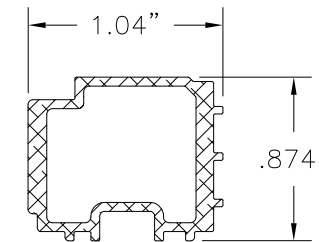

20 SASH BOTTOM RAIL REINFORCEMENT
ALUMINUM 6063-T6 .095" THICK

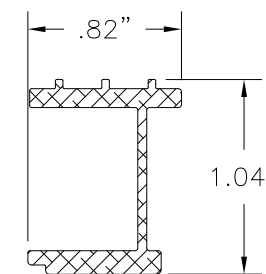

18 SASH STILE REINFORCEMENT
ALUMINUM 6063-T6 .095" THICK

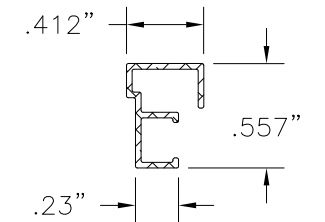

22 FIXED SASH ATTACHMENT SCREW BACKUP
ALUMINUM 6063-T6 .060" THICK

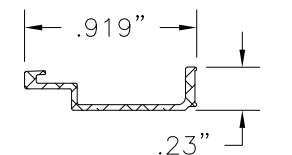

17 FIXED SASH REINFORCEMENT
ALUMINUM 6063-T6 .060" THICK

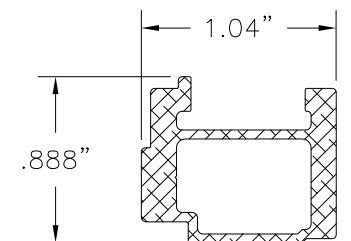

19 SASH TOP RAIL REINFORCEMENT
ALUMINUM 6063-T6 .095" THICK

REVISIONS			
REV	DESCRIPTION	DATE	APPROVED

WinDoor INCORPORATED 7500 AMSTERDAM DRIVE
ORLANDO, FL 32832
Phone: 407.481.8400 Fax: 407.481.0505 www.windoorinc.com

SERIES V-200 PVC SINGLE HUNG WINDOW
60" x 99" - NON-IMPACT COMPONENTS

DRAWN: TJH	DWG NO. 08-01212	REV -
SCALE NTS	DATE 02/02/11	SHEET 7 OF 8



Luis R. Lomas P.E.
Texas No. 101889

REVISIONS			
REV	DESCRIPTION	DATE	APPROVED

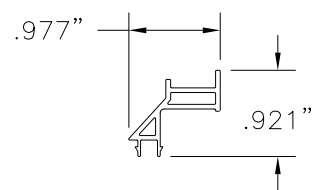

15 **SILL SCREEN TRACK**
EXTRUDED RIGID PVC .050" THICK

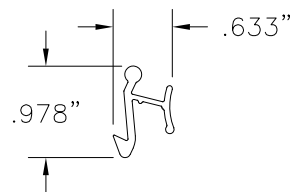

26 **SNAP LATCH HANDLE**
EXTRUDED RIGID PVC .050" THICK

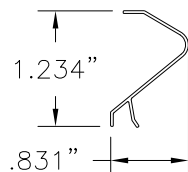

10 **BALANCE COVER**
EXTRUDED RIGID PVC .030" THICK

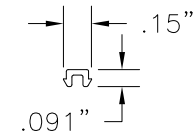

10 **BALANCE COVER**
EXTRUDED RIGID PVC .030" THICK

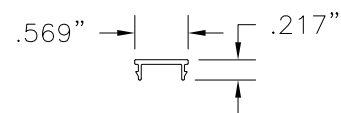

7 **FIXED SASH COVER**
EXTRUDED RIGID PVC .050" THICK

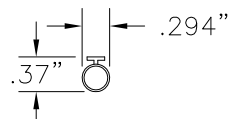

38 **BOTTOM RAIL BULB SEAL**
VINYL

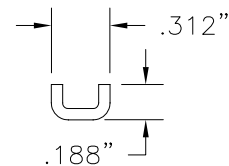

29 **TILT BALANCE PIVOT BAR**
.060" THICK

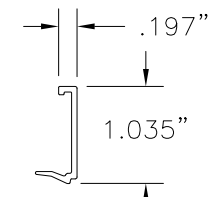

13 **1 1/2" GLASS STOP**
EXTRUDED RIGID PVC .059" THICK

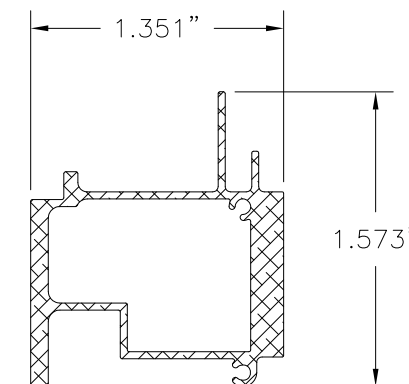

24 **FIXED SASH REINFORCEMENT**
ALUMINUM 6063-T6 .075" THICK

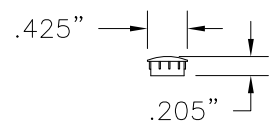

47 **SCREW HOLE PLUG**
EXTRUDED RIGID PVC

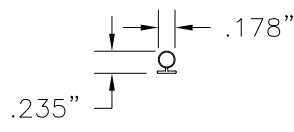

37 **FIXED SASH BULB SEAL**
VINYL

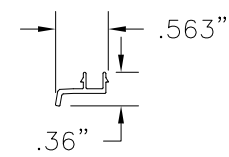

8 **FIXED SASH DRIP CAP**
EXTRUDED RIGID PVC .050" THICK

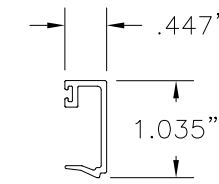

14 **1 1/4" GLASS STOP**
EXTRUDED RIGID PVC .059" THICK

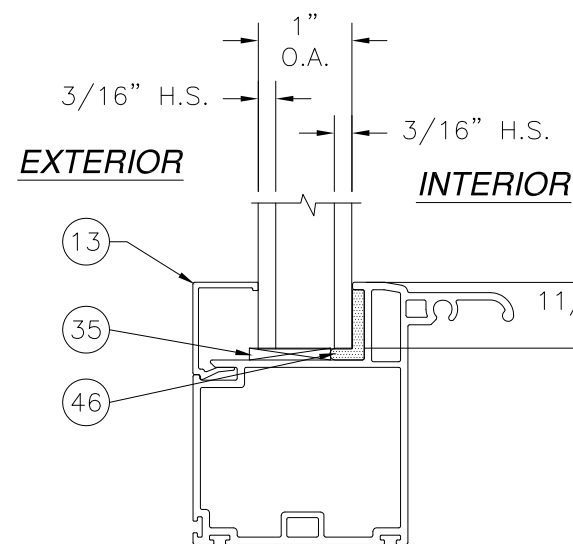

GLAZING OPTION A

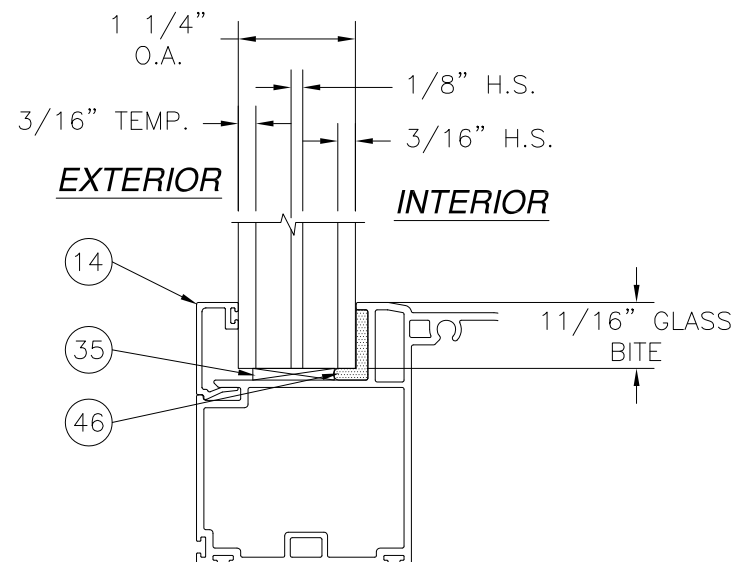

GLAZING OPTION B

WinDoor INCORPORATED		7500 AMSTERDAM DRIVE ORLANDO, FL 32832 Phone: 407.481.8400 Fax: 407.481.0505 www.windowinc.com
SERIES V-200 PVC SINGLE HUNG WINDOW 60" x 99" - NON-IMPACT COMPONENTS		
DRAWN: TJH	DWG NO. 08-01212	REV -
SCALE NTS	DATE 02/02/11	SHEET 8 OF 8

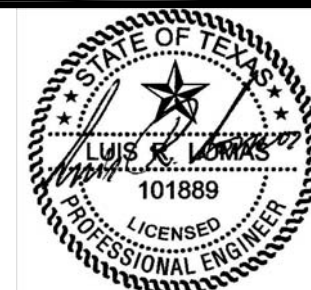

Luis R. Lomas P.E.
Texas No. 101889