

PAN URANIA SPA WALL PANEL SYSTEM EXTERIOR NON-LOAD BEARING IMPACT RATED

GENERAL NOTES:

1. THIS PRODUCT HAS BEEN DESIGNED AND TESTED TO COMPLY WITH THE REQUIREMENTS OF THE 2018 INTERNATIONAL BUILDING CODE (IBC).
2. PANELS COMPLY WITH IMPACT TESTING PERFORMED BY TEL TESTING EVALUATION LABORATORIES, INC.; REPORT #TEL02952231) IN ACCORDANCE WITH THE FOLLOWING TEST SPECIFICATIONS: ASTM E330-02, ASTM E331-00, ASTM E283-04, AND ASTM E1886-05/ASTM E1996-09.
3. THESE PANELS ARE APPROVED FOR AIR AND WATER INFILTRATION PER ASTM E283 AND ASTM E331.
4. THE NON-LOAD BEARING WALL PANELS ARE NOT MECHANICALLY FASTENED TO THE BUILDING MAIN STRUCTURE. THEY ARE DESIGNED TO FIT AND SLIDE ONTO A TRACK/KEY SYSTEM WITHIN THE BUILDING MAIN STRUCTURE. THE PANELS ARE CONNECTED VIA INTERLOCKING PROFILES WITH MALE/FEMALE JOINTS, KEYWAYS AND BOTTOM/TOP LOCKING PROFILES.
5. ALL FRAME CORNERS, JOINTS, MULLION SEAMS, AND PERIMETER GLAZING BEAD TO BE SEALED WITH SILICON SEALANT.
6. LOADING CONDITIONS NOT DEPICTED IN THESE DETAILS ARE NOT PART OF THIS APPROVAL.
7. MATERIALS INCLUDING BUT NOT LIMITED TO STEEL/METAL SCREWS THAT COME INTO CONTACT WITH OTHER DISSIMILAR MATERIALS SHALL MEET THE REQUIREMENTS OF THE 2018 INTERNATIONAL BUILDING CODE (IBC) AS APPLICABLE.
8. METAL STRUCTURE WHICH IS NOT PROVIDED BY PAN URANIA SPA IS TO BE DESIGNED TO SUPPORT THE DEAD/IMPACT LOADS IMPOSED BY THIS WALL PANEL SYSTEM AND TO TRANSFER SUCH LOADS TO THE BUILDING MAIN STRUCTURE. THE WALL PANELS ARE NON-LOAD BEARING.
9. THE DESIGN LOADS IN THIS DOCUMENT ARE ALLOWABLE DESIGN LOADS.

LIMITATIONS OF USE:

1. THIS PRODUCT EVALUATION DOCUMENT (P.E.D) PREPARED BY THIS ENGINEER IS GENERIC AND DOES NOT PROVIDE INFORMATION FOR A SITE SPECIFIC PROJECT; I.E. WHERE THE SITE CONDITIONS DEVIATE FROM THE P.E.D.
2. CONTRACTOR TO BE RESPONSIBLE FOR THE SELECTION, PURCHASE AND INSTALLATION OF THIS PRODUCT BASED ON THIS PRODUCT EVALUATION PROVIDED HE/SHE DOES NOT DEVIATE FROM THE CONDITIONS DETAILED ON THIS DOCUMENT.
3. THIS PRODUCT EVALUATION DOCUMENT WILL BE CONSIDERED INVALID IF ALTERED BY ANY MEANS.
4. SITE SPECIFIC PROJECTS SHALL BE PREPARED BY A TEXAS REGISTERED ENGINEER OR ARCHITECT WHICH WILL BECOME THE ENGINEER OF RECORD (E.O.R.) FOR THE PROJECT AND WHO WILL BE RESPONSIBLE FOR THE PROPER USE OF THE P.E.D.
5. THIS P.E.D. SHALL BEAR THE DATE AND ORIGINAL SEAL AND SIGNATURE OF THE PROFESSIONAL ENGINEER OF RECORD THAT PREPARED IT.

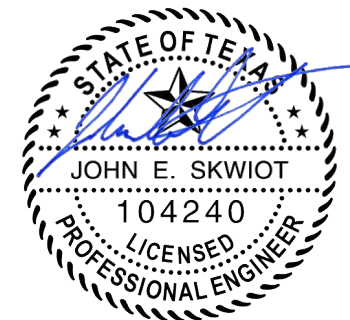

Signed: 11/22/2020

GENERAL NOTES

1. ALL DIMENSIONS ARE IN MILLIMETERS.
2. TOLERANCES (UNLESS STATED OTHERWISE): ±1MM / ±1°

SUPPLIER

PAN URANIA SPA

Issue	Date	Description	By	Check

THIS DRAWING AND ANY INFORMATION OR DESCRIPTIVE MATTER SET HEREON IS THE CONFIDENTIAL PROPERTY OF PAN URANIA; AND MUST NOT BE DISCLOSED, LOANED, COPIED OR USED FOR MANUFACTURING, TENDERING OR ANY OTHER PURPOSE WITHOUT THE PRIOR CONSENT IN WRITING OF PAN URANIA. FOR ANY ISSUE WITH TRANSLATIONS CONTACT US.

COVER

PROJECT
**PRODUCT APPROVAL
WALL PANEL - NON-HVHZ**

Drawn By SF	Drawn Date 3/22/20	Scale NTS		A3
Checked By JS	Check Date 3/22/20	DIMENSIONS ARE IN MM DO NOT SCALE		
Project No.		Order No.		
Dwg No. WP-1		Sheet 1	OF 3	Issue A

ALLOWABLE DESIGN LOADS	
FOR WALL PANEL / WALL PANEL W/ DOOR OPENING	FOR WALL PANEL W/ WINDOW OPENING
+50.0 PSF	+50.0 PSF
-50.0 PSF	-50.0 PSF

DRAWING INDEX	
1	COVER
2	ELEVATION DETAILS
3	SECTION DETAILS

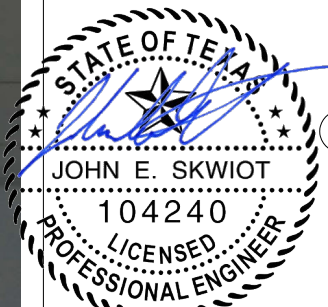

Signed: 11/22/2020

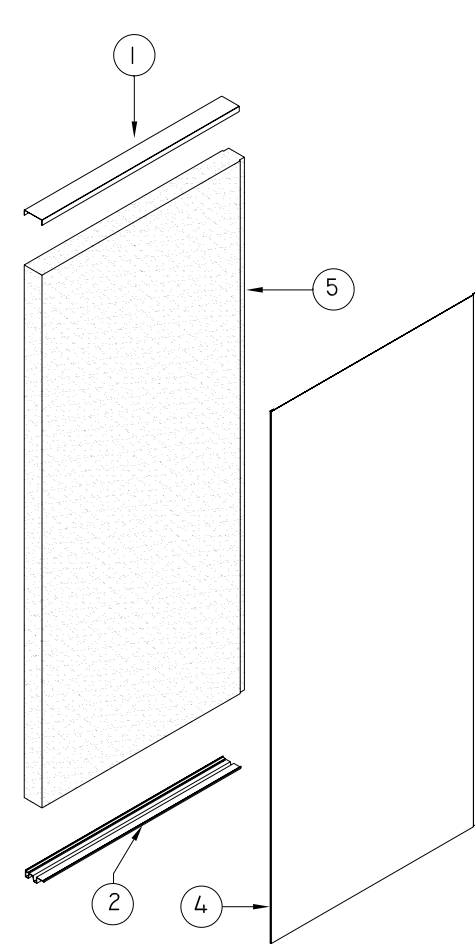

GENERAL NOTES

1. ALL DIMENSIONS ARE IN MILLIMETERS.
2. TOLERANCES (UNLESS STATED OTHERWISE): $\pm 1\text{mm}$ / $\pm 1^\circ$

SUPPLIER

PAN URANIA SPA

Issue	Date	Description	By	Check

THIS DRAWING AND ANY INFORMATION OR DESCRIPTIVE MATTER SET HEREON IS THE CONFIDENTIAL PROPERTY OF PAN URANIA; AND MUST NOT BE DISCLOSED, LOANED, COPIED OR USED FOR MANUFACTURING, TENDERING OR ANY OTHER PURPOSE WITHOUT THE PRIOR CONSENT IN WRITING OF PAN URANIA. FOR ANY ISSUE WITH TRANSLATIONS CONTACT US.

TAG	DESCRIPTION	QTY	MATERIAL
1	TOP PROFILE	1	GALV STEEL
2	BOTTOM PROFILE	1	GALV STEEL
3	SIDE SHEET EXT. (.020/4.33MM THK)	1	RAL 9018 EMBOSSED STEEL
4	SIDE SHEET INT. (.020/4.33MM THK)	1	RAL 9002 EMBOSSED STEEL
5	INSULATION	1	POLYURETHANE

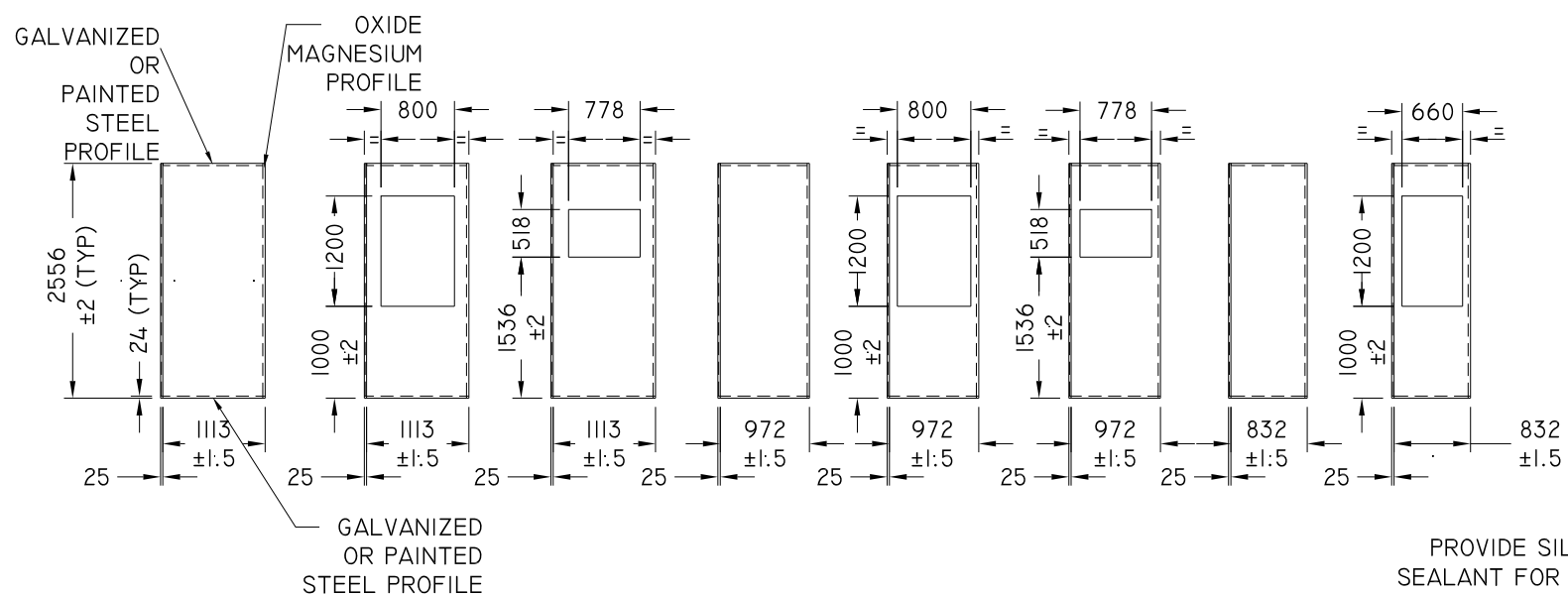

WALL PANEL TYPE OPENINGS

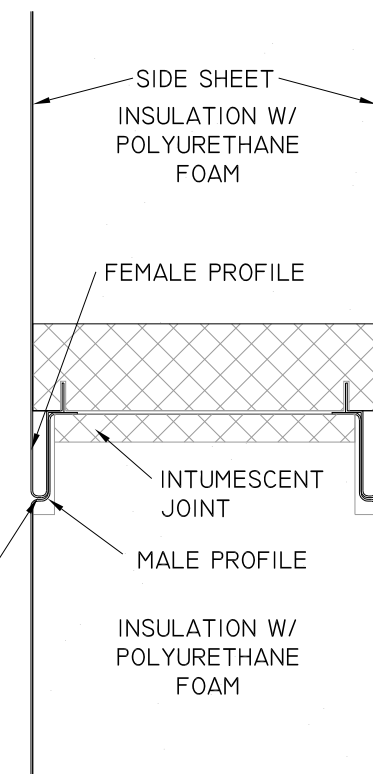

PANEL MATEUP DETAIL

Title

ELEVATION DETAILS

Project

PRODUCT APPROVAL
WALL PANEL - NON-HVHZ

Drawn By SF	Drawn Date 3/22/20	Scale NTS		A3
Checked By JS	Check Date 3/22/20	DIMENSIONS ARE IN MM DO NOT SCALE		

Project No. Order No.

Dwg No. WP-1	Sheet 2 OF 3	Issue A
-----------------	-----------------	------------

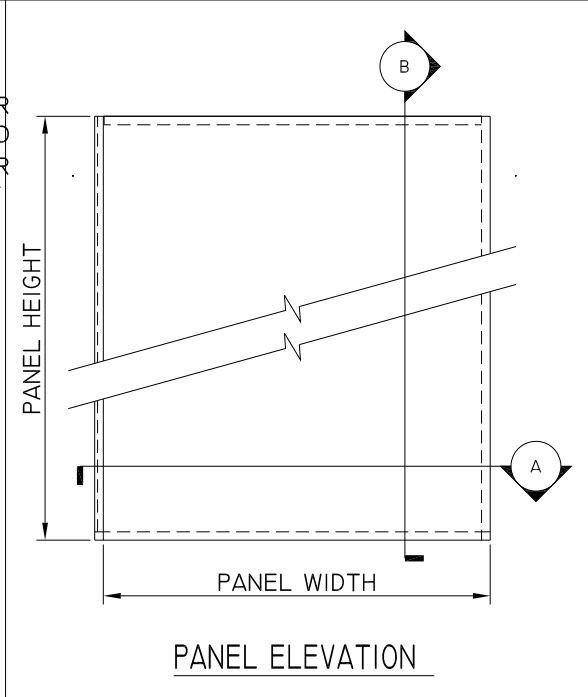
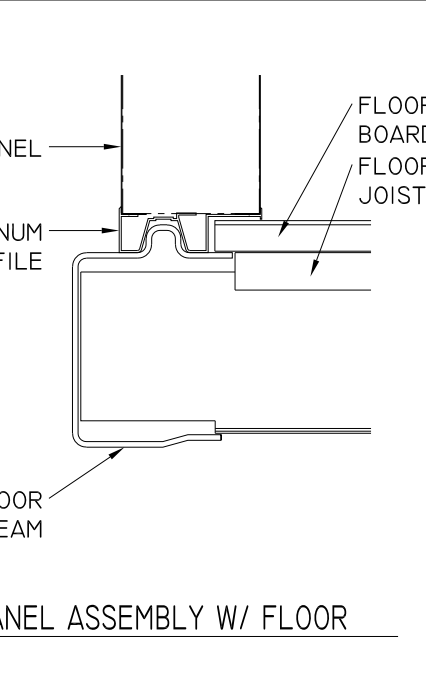
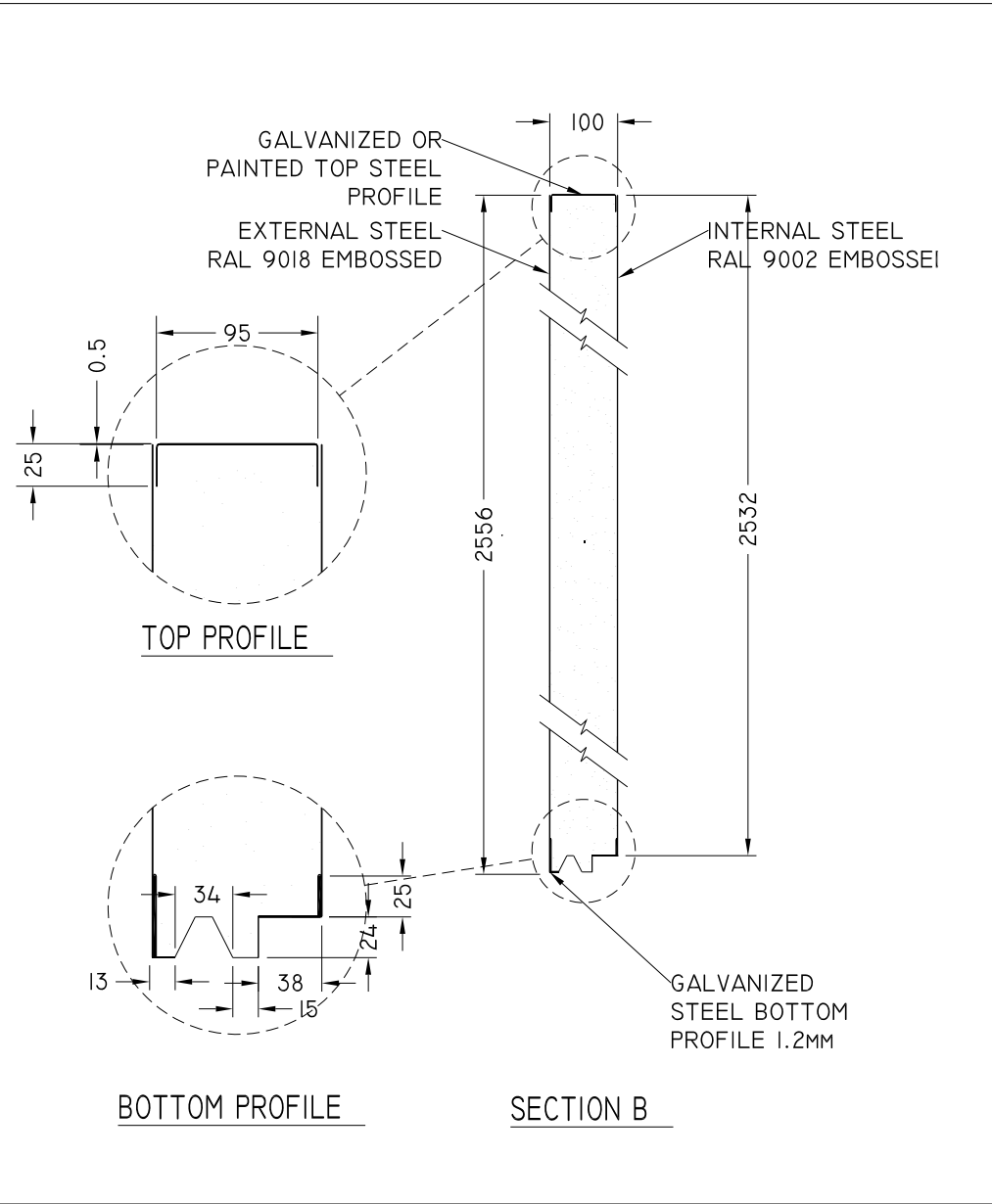
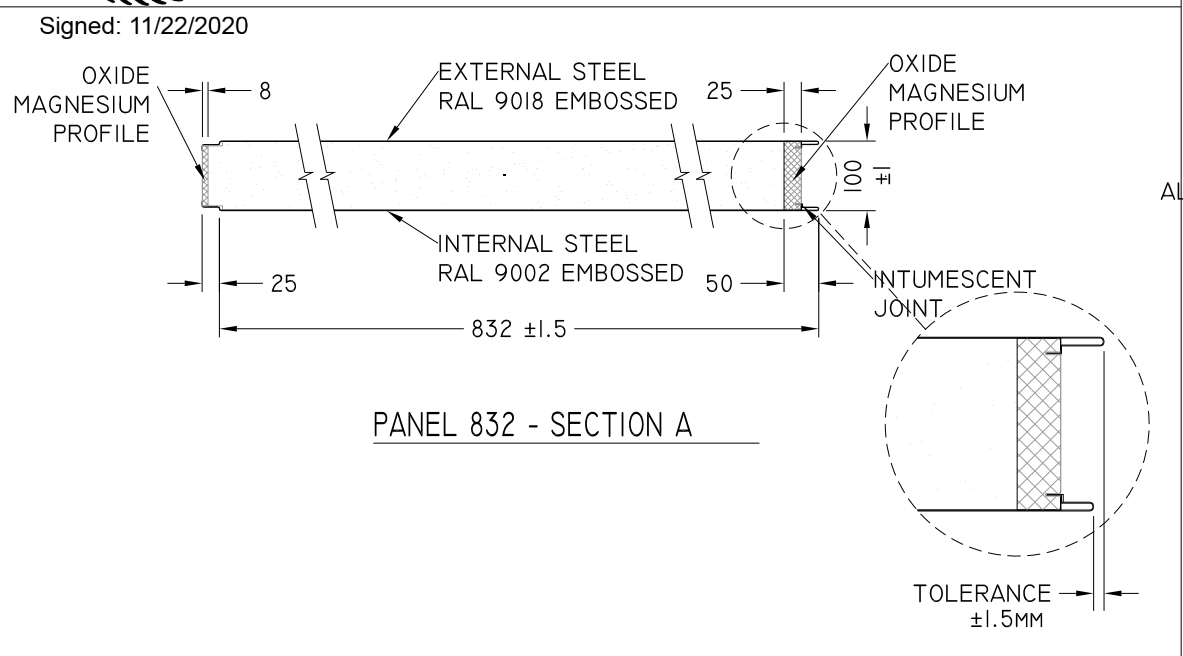
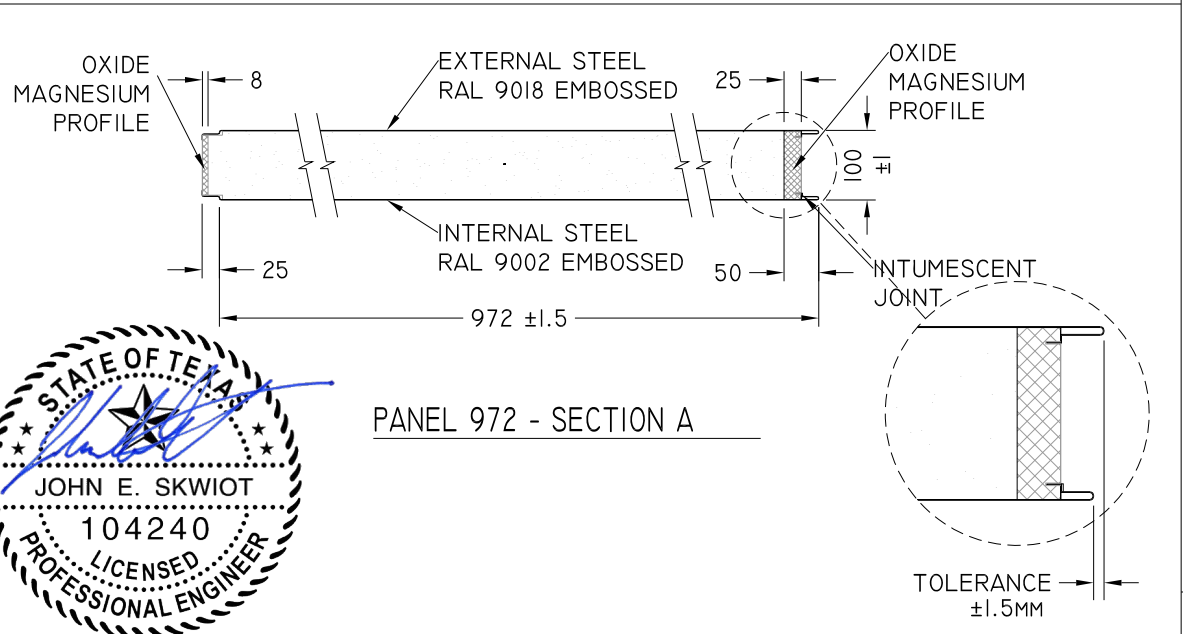
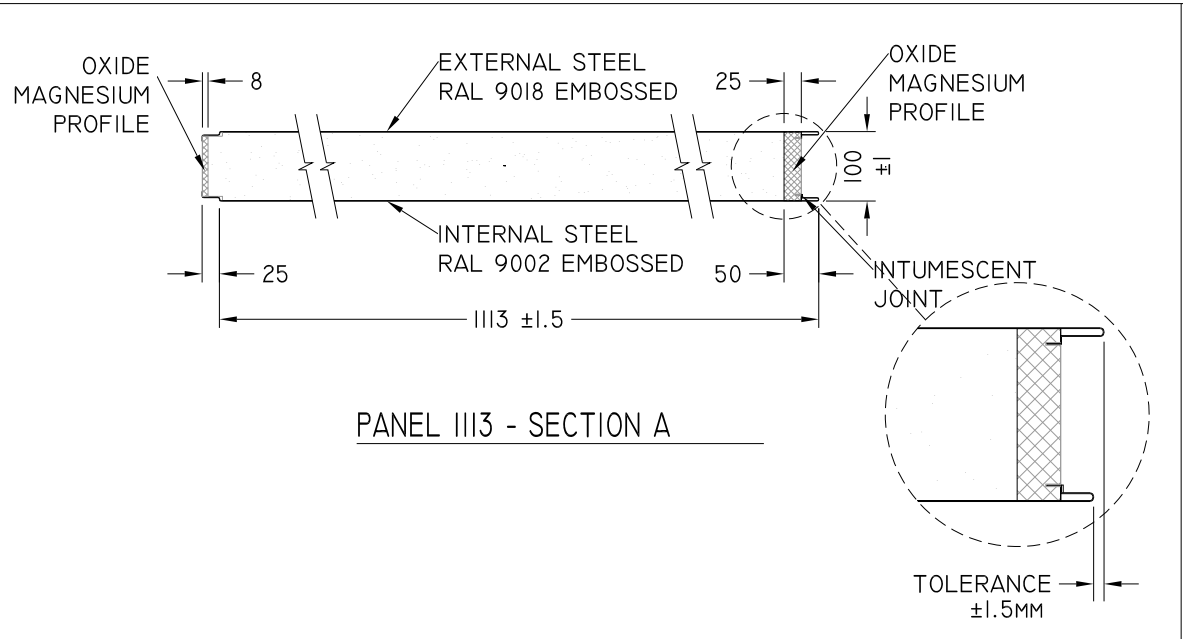

GENERAL NOTES

- ALL DIMENSIONS ARE IN MILLIMETERS.
- TOLERANCES (UNLESS STATED OTHERWISE): ±1MM / ±1°

SUPPLIER

PAN URANIA SPA

Issue	Date	Description	By	Check

THIS DRAWING AND ANY INFORMATION OR DESCRIPTIVE MATTER SET HEREON IS THE CONFIDENTIAL PROPERTY OF PAN URANIA; AND MUST NOT BE DISCLOSED, LOANED, COPIED OR USED FOR MANUFACTURING, TENDERING OR ANY OTHER PURPOSE WITHOUT THE PRIOR CONSENT IN WRITING OF PAN URANIA. FOR ANY ISSUE WITH TRANSLATIONS CONTACT US.

SECTION DETAILS

Project

**PRODUCT APPROVAL
WALL PANEL - NON-HVHZ**

Drawn By SF	Drawn Date 3/22/20	Scale NTS		A3
Checked By JS	Check Date 3/22/20	DIMENSIONS ARE IN MM DO NOT SCALE		
Project No.		Order No.		
Dwg No. WP-1	Sheet 3 OF 3	Issue A		

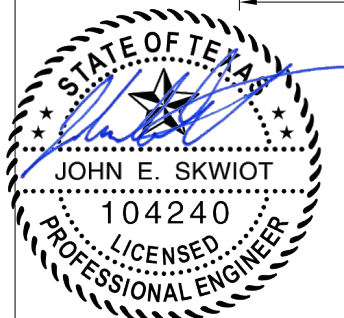

Signed: 11/22/2020